

## Mightyband™ Coil Heaters



**M**  
**MIGHTYBAND™**

*The Superior Coil Heater Design  
with a Built-In Thermocouple*

U.S. Patents #4150281 and #4253011

### Design Features

- \* Temperatures up to 1800°F (982°C)
- \* Precise temperature control
- \* Choice of lead orientation
- \* Built-in type J or K Thermocouple
- \* Round, square and rectangular cable
- \* Rugged, durable construction
- \* Unheated straight section
- \* Fast response time
- \* Choice of lead protection
- \* Longer heater life
- \* Higher watt densities
- \* Made to customer specifications

### Applications

Tempco offers from stock a large selection of standard Mightyband coil heaters for plastic injection runnerless molding bushings and for internally heated injection machine nozzles. The inside diameter of a coiled heater is wound undersized for a screw-on fit. Therefore, hold-down straps are not usually required.

### Construction Characteristics

Tempco's dedication to quality and product improvement has led us to the development of a second generation of Mightyband heaters.

Manufactured for trouble-free performance in operations involving heating of cylindrical-shaped surfaces where precise temperature control is essential. Especially adapted as an alternate heat source for demanding and high temperature applications where other types of heaters have failed.

The design and manufacturing concept incorporates a built-in thermocouple, with a grounded junction terminating at the end of the cable opposite to the lead end. In some heaters, the thermocouple junction can be terminated anywhere within the coil section. Consult Tempco for the availability of this option on your specific heater.

The built-in thermocouple and the overall low mass construction provide quick response for positive temperature control. Incorporating the thermocouple into the heater construction eliminates the need for separate thermocouples, which have proven to be expensive, fragile and impractical.

Tempco Mightyband heaters have opened new frontiers and revolutionized the plastic injection runnerless molding industry since their introduction by Tempco in 1977. They provided the manufacturers of this type of equipment with a new and more effective heating element concept, thus allowing them to design and manufacture new, improved, and more efficient runnerless molding systems, with the capabilities required

to meet the ever-increasing demand for processing engineering resins and high production output requirements of today's industrial and consumer markets.

One specific way to improve the Mightyband heater design is to use a square or rectangular mineral insulated cable, which has a flat surface contact, allowing better heat conduction and a faster start-up time.

A  
.....  
REVOLUTIONARY  
.....  
CONCEPT  
.....  
IN  
.....  
HEATER  
.....  
DESIGN  
.....

Standard Type J thermocouple with 304 stainless steel heater sheath is recommended for temperatures up to 1500°F (815°C). An optional Type K thermocouple with Inconel® 600 heater sheath for temperatures up to 1800°F (982°C) is available upon request. In some applications, the built-in thermocouple may not be required. In this case, it can be omitted from the heater cable.

The heating source for the Mightyband heater is a resistance wire in straight form or wound into a miniature helical coil. Selecting the best-suited resistance wire configuration is predetermined by an engineering formula applied to the specific heater design.

On Mightyband heaters where wire wound resistance coils are used, the tail end of the heater cable is usually unheated. Optional unheated or cooler tail sections are available on straight resistance wire heater designs. Consult Tempco with your specific requirements.

The swaging and drawing process involved in manufacturing the heater cable for Mightyband heaters compacts the ceramic insulators that house the heating element and thermocouple wire into a solid mass, producing a rugged and durable heater cable, providing excellent thermal conductivity, dielectric strength and quick thermocouple response.

### Mightyband™ Coil Heater Specifications

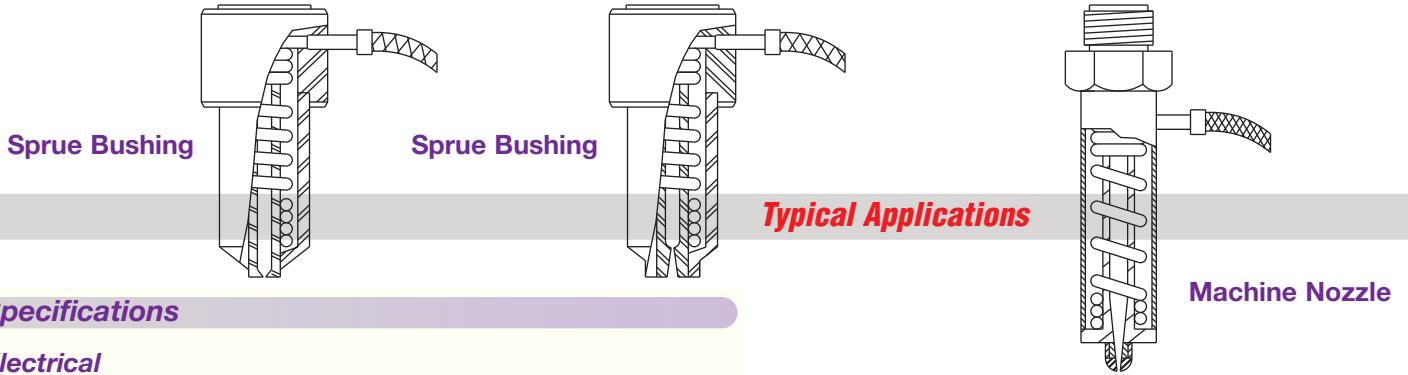

#### Specifications

##### Electrical

- Resistance Tolerance: ..... ±10%
  - Wattage Tolerance: ..... ±10%
  - Maximum Amperage: ..... 20 Amps
  - Standard Voltage: ..... 120 or 240 Volts
- Higher or lower voltages applicable for specific heater designs; consult Tempco with your requirements.*

##### Dimensional

- Standard square cable: ..... 0.125", 0.134" square
- Standard rectangular cable: ..... 0.110" × 0.160"
- Standard round cable diameters: ..... 0.115", 0.120", 0.125"  
0.132", 0.153", 0.163"  
*Others available upon request.*
- Cable diameter tolerance: ..... ±0.005
- Standard potting adapter: ..... 5/16" Diameter  
*Used with heater only and heater with T/C leads, 20 gauge and under.*
- ..... 1/2" Diameter  
*Used with heater only and heater with T/C leads, 18 gauge to 10 gauge.*
- Standard potting adapter length: ..... 1-1/2"  
*Other lengths available.*
- Standard coil I.D.: ..... From 3/8" up to 2-1/2" in any increments.  
*Applicable Coil I.D. is subject to cable diameter.*
- Coil I.D. Tolerance: ..... 3/8" to 3/4", +0.000", -0.020"  
..... 7/8" to 1-1/4", +0.000", -0.030"  
..... 1-1/2" to 2-1/2", +0.000", -0.060"
- Coil Width (length): ..... Up to 12" on 3/8" to 3/4" I.D.  
..... Up to 16" on 7/8" to 1-1/4" I.D.  
..... Up to 18" on 1-1/2" to 2-1/2"
- Coil Width Tolerance: ..... 0 to 6": +0, -1/8"  
..... 6 to 12": +1/8", -1/4"  
..... 12 to 18": ±1/4"
- Standard Sheath Material: ..... 304 stainless steel  
*For temperatures up to 1500°F (815°C)*
- Optional Sheath Material: ..... Inconel® 600  
*For temperatures up to 1800°F (982°C)*
- Standard Thermocouple: ..... ANSI Type J
- Optional Thermocouple: ..... ANSI Type K
- Minimum Bending Radius: ..... Two times the sheath diameter

#### Typical Configurations

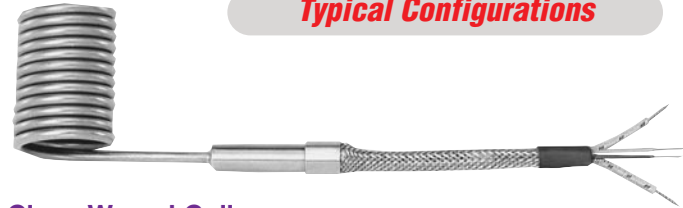

Close Wound Coil



Distributed Wattage

By specifically arranging a coiling pattern on the heater cable, heat distribution can be concentrated where it is needed. Useful to compensate for heat losses along the edges of the part being heated. Specify concentration.



Clamping Straps

Mightybands normally do not require clamping straps as the inside diameter of the coil is wound undersize for a screw fit. At times because of differences in the expansion and contraction in materials a clamping strap may be required to ensure circumferential clamping forces. Clamping straps also provide additional protection of the heater coils from accidental damage. If optional clamping strap is required, specify.

### Special Coil Heater Configurations

#### Star Wound Coil



Star wound formations are usually inserted into pipes or ducts and are used to heat moving air or liquids. The offset coils create a turbulent flow. This allows the flowing material to have better contact with the heater surface, resulting in more efficient heat transfer.

#### Explosion or Moisture Resistant Box

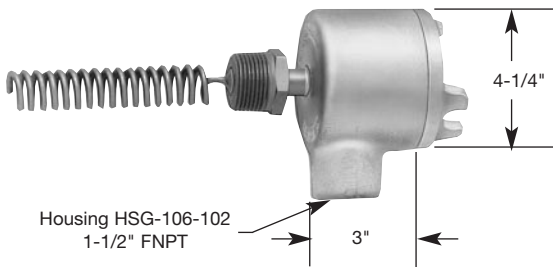

Mightyband coil heaters can be used for immersion heating and/or in-line heating of liquids, gases or air. The built-in thermocouple provides a self-contained heating unit, eliminating the need for separate thermowells, and is available with standard NPT or special fittings. The outside diameter (O.D.) of the coil must be smaller than the fitting being used for proper fit to the mating part. The wiring can be protected from hazardous environments by attaching explosion or moisture-proof boxes. Consult Tempco with your requirements.

#### NPT Pipe Fittings



Mightyband coil heaters can be used for immersion heating and/or in-line heating of liquids, gases or air. The built-in thermocouple provides a self-contained heating unit, eliminating the need for separate thermowells. Available with standard NPT fittings or special fittings. The outside diameter (O.D.) of the coil must be smaller than the fitting being used for proper fit to the mating part. Consult Tempco with your requirements.

### Lead Orientations

#### LO1 Standard

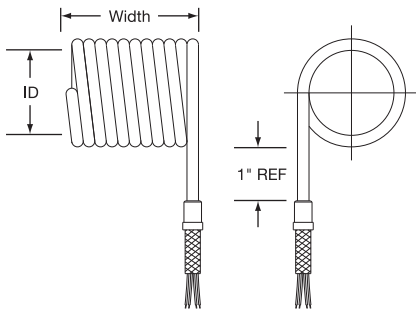

#### LO2

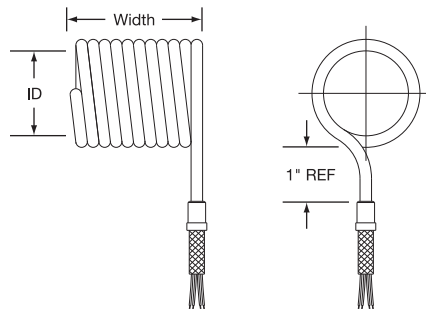

#### LO3

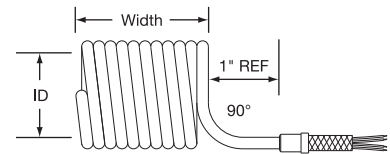

#### LO4

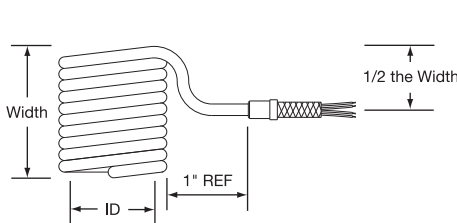

#### LO5

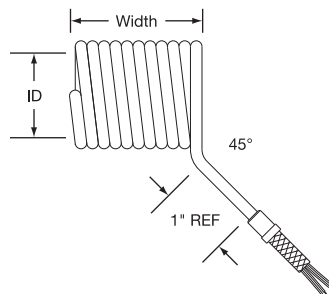

#### LO6

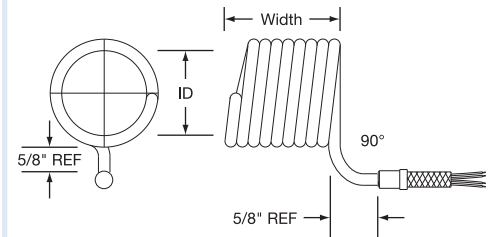

**Note:** Lead orientations can be custom formed. Consult Tempco with your requirements. We welcome your inquiries.



### Potting Adapter Lead Terminations

- The heating element wire to lead wire transition is done within the potting adapter. Potting adapter sizes are 5/16" O.D. × 1-1/2" long for heater cable diameters 0.188" and smaller and 1/2" × 1-1/2" long for diameters above 0.188". Other diameters and lengths are available, depending on design parameters.
- When the 1/2" × 1-1/2" long potting adapter is used for high temperature applications, a special heat sink collar is also used to help keep the transition from overheating.
- All transitions use 1150°F (621°C) braze joint between the heating element wire and the flexible lead wire.
- Normally the lead wire construction is a fiberglass braided insulation rated to 482°F (250°C). For high temperature applications an MGT (mica, fiberglass, Teflon® impregnation) insulation rated to 842°F (450°C) is used. All thermocouple leads use a fiberglass insulation rated to 900°F (482°C). Lead wires are selected to meet the amperage and temperature requirements of each specific heater.

#### Type M\_\_ – Plain Leads

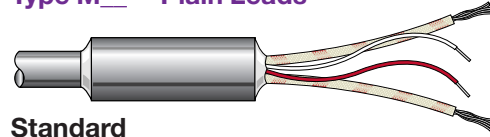

##### Standard

**M1** – High temperature cement potting with TGGT (Teflon® tape, fiberglass, Teflon® treated fiberglass overbraid) insulated lead wire for 482°F (250°C) and silicone sealed is standard.

##### Optional

**M2** – High temperature epoxy potting rated 450°F (232°C) with PTFE Teflon® lead wire for a better moisture seal.

##### Optional

**M3** – High temperature cement potting with MGT (mica tape, Teflon® treated fiberglass overbraid) insulated lead wire for 842°F (450°C) and silicone sealed.



**Note:** Temperature at potting adapter should not exceed the specified limits.

### Lead Wire Abrasion Protection Terminations

#### Type A\_\_ – Stainless Steel Armor Cable

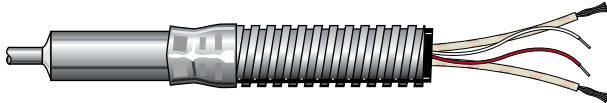

**Type A1** – Rated to 482°F (250°C) – TGGT Fiberglass Wire

**Type A2** – Rated to 450°F (232°C) – Teflon® Wire

**Type A3** – Rated to 842°F (450°C) – MGT Fiberglass Wire

Flexible SS armor cable protects the leads against abrasion and contamination. Special plugs can be attached to heater leads and thermocouple leads.

#### Type C\_\_ – Galvanized Armor Cable



**Type C1** – Rated to 482°F (250°C) – TGGT Fiberglass Wire

**Type C2** – Rated to 450°F (232°C) – Teflon® Wire

**Type C3** – Rated to 842°F (450°C) – MGT Fiberglass Wire

Flexible galvanized armor cable protects the leads against abrasion and contamination. Special plugs can be attached to heater leads and thermocouple leads.

#### Type B\_\_ – Stainless Steel Overbraid

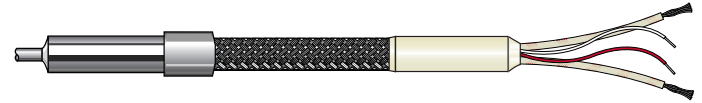

**Type B1** – Rated to 482°F (250°C) – TGGT Fiberglass Wire

**Type B2** – Rated to 450°F (232°C) – Teflon® Wire

**Type B3** – Rated to 842°F (450°C) – MGT Fiberglass Wire

SS overbraid protects the leads against abrasion and allows more aggressive bending, which is not possible with armor cable. Special plugs can be attached to heater and thermocouple leads.

#### Type S\_\_ – Fiberglass Sleeve

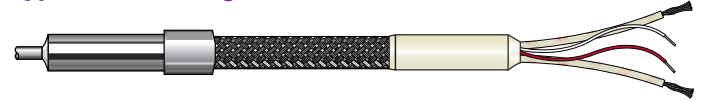

**Type S1** – Rated to 482°F (250°C) – TGGT Fiberglass Wire

**Type S2** – Rated to 450°F (232°C) – Teflon® Wire

**Type S3** – Rated to 842°F (450°C) – MGT Fiberglass Wire

Fiberglass sleeve protects the leads against abrasion and allows more flexibility of lead wires. Special plugs can be attached to heater and thermocouple leads.

### Optional Heater Cable Cold End

The availability of Tempco-Pak heaters with optional cold heater cable end depends on the electrical ratings and materials used for each heater design. Consult Tempco for the availability of these options.

#### Type ND – Neck Down

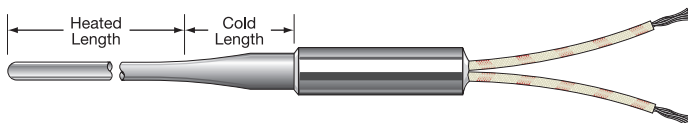

#### Type NW – Built-in Cold Wire

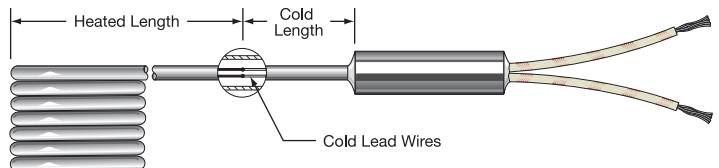



## Mightyband™ Coil Heaters

### Mightyband™ Coil Heaters

Heater shown with Lead Protection Type B and Lead Orientation LO1.



### Standard (Non-Stock) Round Cable Heaters

Standard Cable Heaters have 304 Stainless Steel Sheath

Inside Diameter		Outside Diameter		Width		Watts	Volts	Distributed Wattage	Close Wound	Lead Protection	Lead Orientation	Part Number
in	mm	in	mm	in	mm							
½	12.7	0.808	20.5	2	50.8	340	240	yes		C1	LO2	MHC00001
½	12.7	0.808	20.5	2½	63.5	340	240	yes		C1	LO2	MHC00002
½	12.7	0.808	20.5	3	76.2	340	240	yes		C1	LO2	MHC00003
½	12.7	0.808	20.5	3½	88.9	340	240	yes		C1	LO2	MHC00004
½	12.7	0.808	20.5	3	76.2	380	240	yes		C1	LO2	MHC00005
½	12.7	0.808	20.5	3½	88.9	380	240	yes		C1	LO2	MHC00006
½	12.7	0.730	18.5	2½	63.5	450	240		yes	C1	LO1	MHC00007
½	12.7	0.764	19.4	4½	114.3	400	240	yes		C1	LO2	MHC00008
½	12.7	0.750	19.1	5½	139.7	400	240	yes		C1	LO2	MHC00009
½	12.7	0.750	19.1	6½	165.1	400	240	yes		C1	LO2	MHC00010
½	12.7	0.750	19.1	4¾	117.5	300	240		yes	C1	LO1	MHC00011
½	12.7	0.712	18.1	2	50.8	340	120		yes	C1	LO2	MHC00012
½	12.7	0.764	19.4	2½	63.5	340	120	yes		C1	LO2	MHC00013
½	12.7	0.764	19.4	3	76.2	380	120	yes		C1	LO2	MHC00014
½	12.7	0.764	19.4	3½	88.9	380	120	yes		C1	LO2	MHC00015
½	12.7	0.744	18.9	4½	114.3	400	120	yes		C1	LO2	MHC00016
½	12.7	0.744	18.9	5½	139.7	400	120	yes		C1	LO2	MHC00017
½	12.7	0.744	18.9	6½	165.1	400	120	yes		C1	LO2	MHC00018
½	12.7	0.750	19.1	4¾	117.5	300	120		yes	C1	LO1	MHC00019
❖ ⅜	15.9	0.931	23.6	2	50.8	300	240	yes		C1	LO2	MHC00020
❖ ⅜	15.9	0.931	23.6	2½	63.5	325	240	yes		C1	LO2	MHC00021
⅜	15.9	0.891	22.6	2	50.8	330	120		yes	B1	LO2	MHC00022
⅜	15.9	0.875	22.2	2	50.8	330	240		yes	B1	LO2	MHC00023
⅜	15.9	0.875	22.2	2½	63.5	330	240	yes		B1	LO2	MHC00024
⅜	15.9	0.875	22.2	3	76.2	330	240	yes		B1	LO2	MHC00025
⅜	15.9	0.875	22.2	3	76.2	380	240	yes		C1	LO2	MHC00026
⅜	15.9	0.875	22.2	3	76.2	360	240		yes	B1	LO2	MHC00027
⅜	15.9	0.875	22.2	4	101.6	360	240	yes		B1	LO2	MHC00028
⅜	15.9	0.875	22.2	4	101.6	500	240		yes	B1	LO2	MHC00029
⅜	15.9	0.875	22.2	5	127.0	500	240	yes		C1	LO2	MHC00030
❖ ⅜	15.9	0.875	22.2	6	152.4	550	240	yes		C1	LO2	MHC00031
¾	19.1	1.056	26.8	1¼	31.8	250	230		yes	M†	LO1	MHC00032
¾	19.1	1.056	26.8	1¼	31.8	125	230		yes	M†	LO1	MHC00033
¾	19.1	1.056	26.8	1¼	31.8	400	120		yes	B1	LO1	MHC00034
¾	19.1	1.000	25.4	2	50.8	365	120		yes	B1	LO1	MHC00035
¾	19.1	1.056	26.8	2	50.8	135	240		yes	B1	LO1	MHC00036
¾	19.1	1.000	25.4	3	76.2	750	240		yes	B1	LO1	MHC00037
¾	19.1	0.972	24.7	5	127.0	600	240		yes	B1	LO1	MHC00038
¾	19.1	0.992	25.2	8½	215.9	1300	240		yes	B1	LO1	MHC00039
⅞	22.2	1.181	30.0	1	25.4	400	120		yes	B1	LO1	MHC00040
⅞	22.2	1.181	30.0	1¼	31.8	250	240		yes	M†	LO2	MHC00041
❖ ⅞	22.2	1.181	30.0	2	50.8	400	240	yes		C1	LO2	MHC00042
⅞	22.2	1.181	30.0	2¾	66.7	480	240	yes		C1	LO2	MHC00043
⅞	22.2	1.181	30.0	3¾	79.4	480	240	yes		C1	LO2	MHC00044



**Note:** ❖ Denotes the Thermocouple Junction is located between third and fourth coil from the tip end, isolated from the sheath. † Cement Potted Teflon® insulated SPC wire. See page 5-5 for Lead Protection and page 5-4 for Lead Orientation descriptions.





### Mightyband™ Coil Heaters

#### Standard (Non-Stock) Round Cable Heaters

Standard Cable Heaters have 304 Stainless Steel Sheath

Inside Diameter		Outside Diameter		Width		Watts	Volts	Distributed Wattage	Close Wound	Lead Protection	Lead Orientation	Part Number
in	mm	in	mm	in	mm							
7/8	22.2	1.115	28.3	2	50.8	670	120		yes	B3	LO2	MHC00045
7/8	22.2	1.125	28.6	2	50.8	670	240		yes	B1	LO2	MHC00046
7/8	22.2	1.125	28.6	2 1/2	63.5	670	240	yes		B1	LO2	MHC00047
7/8	22.2	1.125	28.6	3 3/8	79.4	670	240	yes		B1	LO2	MHC00048
❖ 7/8	22.2	1.181	30.0	2 1/2	63.5	450	240	yes		C1	LO2	MHC00049
7/8	22.2	1.181	30.0	3 3/8	92.1	550	240	yes		C1	LO2	MHC00050
7/8	22.2	1.181	30.0	4 3/16	109.5	550	240	yes		C1	LO2	MHC00051
7/8	22.2	1.181	30.0	5 1/16	134.9	650	240	yes		C1	LO2	MHC00052
7/8	22.2	1.181	30.0	6 3/16	160.3	650	240	yes		C1	LO2	MHC00053
7/8	22.2	1.181	30.0	7 1/16	185.7	650	240	yes		C1	LO2	MHC00054
❖ 7/8	22.2	1.125	28.6	3	76.2	680	240	yes		C1	LO2	MHC00055
❖ 7/8	22.2	1.125	28.6	3 1/2	88.9	700	240	yes		C1	LO2	MHC00056
7/8	22.2	1.125	28.6	3 3/8	92.1	770	240	yes		B1	LO2	MHC00057
7/8	22.2	1.125	28.6	4 3/16	109.5	770	240	yes		B1	LO2	MHC00058
7/8	22.2	1.125	28.6	5 3/16	134.9	770	240	yes		B1	LO2	MHC00059
7/8	22.2	1.125	28.6	4	101.6	775	240	yes		C1	LO2	MHC00060
7/8	22.2	1.125	28.6	6 3/16	160.3	730	240	yes		B1	LO2	MHC00061
7/8	22.2	1.125	28.6	7 1/16	185.7	730	240	yes		B1	LO2	MHC00062
❖ 7/8	22.2	1.125	28.6	5	127.0	900	240	yes		C1	LO2	MHC00063
7/8	22.2	1.105	28.1	8 5/16	211.1	730	240	yes		C1	LO2	MHC00064
7/8	22.2	1.105	28.1	9 3/16	236.5	730	240	yes		C1	LO2	MHC00065
7/8	22.2	1.105	28.1	10 3/16	261.9	730	240	yes		C1	LO2	MHC00066
❖ 7/8	22.2	1.125	28.6	6	152.4	1000	240	yes		C1	LO2	MHC00067
7/8	22.2	1.105	28.1	11 3/16	287.3	850	240	yes		C1	LO2	MHC00068
7/8	22.2	1.105	28.1	12 3/16	312.7	850	240	yes		C1	LO2	MHC00069
7/8	22.2	1.105	28.1	13 3/16	338.1	850	240	yes		C1	LO2	MHC00070
7/8	22.2	1.105	28.1	14 3/16	363.5	850	240	yes		C1	LO2	MHC00071
7/8	22.2	1.105	28.6	7	177.8	1100	240	yes		C1	LO2	MHC00072
1	25.4	1.250	31.8	1 1/2	38.1	375	120		yes	B1	LO1	MHC00073
1	25.4	1.306	33.2	1 1/2	38.1	375	240		yes	B1	LO1	MHC00074
1	25.4	1.240	31.5	2	50.8	400	120		yes	B1	LO1	MHC00075
1	25.4	1.266	32.2	2 1/2	63.5	450	120		yes	B1	LO1	MHC00076
1	25.4	1.250	31.8	8	203.2	1250	240		yes	B3	LO1	MHC00077
1 1/4	31.8	1.556	39.5	1	25.4	340	240		yes	B1	LO1	MHC00078
1 1/4	31.8	1.556	39.5	1 1/4	31.8	375	120		yes	B1	LO1	MHC00079
1 1/4	31.8	1.480	37.6	1 1/2	38.1	400	120		yes	B1	LO1	MHC00080
1 1/4	31.8	1.492	37.9	2	50.8	475	120		yes	B1	LO1	MHC00081
1 1/4	31.8	1.480	37.6	2 1/2	63.5	750	240		yes	C1	LO2	MHC00082
1 1/4	31.8	1.514	38.5	4 1/2	114.3	1250	240		yes	C3	LO2	MHC00083
1 1/4	31.8	1.534	39.0	6 1/2	165.1	1800	240		yes	C3	LO2	MHC00084
1 1/4	31.8	1.548	39.3	7	177.8	2000	240		yes	B3	LO1	MHC00085
1 1/4	31.8	1.594	40.5	8 1/2	215.9	2335	240		yes	C3	LO2	MHC00086
1 1/4	31.8	1.626	41.3	10 1/2	266.7	2500	240		yes	C1	LO2	MHC00087



**Note:** ❖ Denotes the Thermocouple Junction is located between third and fourth coil from the tip end, isolated from the sheath. See page 5-5 for Lead Protection and page 5-4 for Lead Orientation descriptions.

### Ordering Information

See page 5-9

**CONTINUED**

### Mightyband™ Coil Heaters

Continued from previous page...

Heater shown with  
Lead Protection B and  
Lead Orientation LO1.



### Standard (Non-Stock) Round Cable Heaters

Standard Cable Heaters have 304 Stainless Steel Sheath

Inside Diameter		Outside Diameter		Width		Watts	Volts	Distributed Wattage	Close Wound	Lead Protection	Lead Orientation	Part Number
in	mm	in	mm	in	mm							
1½	38.1	1.806	45.9	1	25.4	400	120		yes	B1	LO1	MHC00088
		1.730	43.9	1¼	31.8	425	120		yes	B1	LO1	MHC00089
		1.742	44.2	1½	38.1	525	120		yes	B1	LO1	MHC00090
		1.742	44.2	2	50.8	475	120		yes	B1	LO1	MHC00091
		1.752	44.5	2	50.8	475	240		yes	B1	LO1	MHC00092
		1.754	44.6	2	50.8	550	240		yes	B1	LO1	MHC00093
		1.742	44.2	2½	63.5	600	120		yes	B3	LO1	MHC00094
		1.766	44.9	2½	63.5	600	240		yes	B3	LO1	MHC00095
		1.742	44.2	3	76.2	475	120		yes	B1	LO1	MHC00096
		1.732	44.0	3	76.2	875	240		yes	B1	LO2	MHC00097
		1.750	44.5	4¾	104.8	1000	240	yes		C3	LO2	MHC00098
		1.732	44.0	4	101.6	1000	240		yes	B3	LO2	MHC00099
		1.750	44.5	5½	130.2	1000	240	yes		C3	LO2	MHC00100
		1.742	44.2	5	127.0	1200	240		yes	B3	LO1	MHC00101
		1.766	44.9	6¾	155.6	1200	240	yes		B3	LO2	MHC00102
		1.750	44.5	7¾	181.0	1100	240	yes		C1	LO2	MHC00103
		1.806	45.9	6	152.4	675	120		yes	B3	LO1	MHC00104
		1.750	44.5	6	152.4	1200	240		yes	B3	LO2	MHC00105
1.766	44.8	8¾	206.4	1250	240	yes		B3	LO2	MHC00106		
1.796	45.6	9¾	231.8	1400	240	yes		B3	LO2	MHC00107		
1.826	46.4	10¾	257.2	1800	240	yes		B3	LO2	MHC00108		
1¼	44.5	1.982	50.3	1	25.4	475	120		yes	B1	LO1	MHC00109
		2.000	50.8	1½	38.1	625	240		yes	B1	LO1	MHC00110
		2.000	50.8	2	50.8	675	240		yes	B1	LO1	MHC00111
		1.982	50.3	2½	63.5	725	240		yes	B1	LO1	MHC00112
		2.056	52.2	7	177.8	2000	240		yes	B3	LO2	MHC00113
2	50.8	2.250	57.2	1¾	34.9	450	240		yes	B1	LO1	MHC00114
		2.326	59.1	6½	165.1	2400	240		yes	B3	LO1	MHC00115



**Note:** See page 5-5 for Lead Protection and page 5-4 for Lead Orientation descriptions.



### Standard (Non-Stock) Tempco Replacement Coil Heaters for OEM Hot Runner Bushings

Standard Cable Heaters have 304 Stainless Steel Sheath

Inside Diameter in mm	Outside Diameter		Width		Watts	Volts	Distributed Wattage	Close Wound	OEM Part Number	TEMPCO Part Number
	in	mm	in	mm						
½ 12.7	0.808	20.5	3	76.2	380	240	yes		KH-52030	MHC00005
	0.808	20.5	3½	88.9	380	240	yes		KH-52035	MHC00006
	0.764	19.4	4½	114.3	400	240	yes		KH-53045	MHC00008
	0.750	19.1	5½	139.7	400	240	yes		KH-53555	MHC00009
	0.750	19.1	6½	165.1	400	240	yes		KH-53565	MHC00010
	0.764	19.4	2	50.8	340	120		yes	KH-520	MHC00012
	0.764	19.4	2½	63.5	340	120	yes		KH-52025	MHC00013
	0.764	19.4	3	76.2	380	120	yes		KH-52030	MHC00014
	0.764	19.4	3½	88.9	380	120	yes		KH-52035	MHC00015
	0.744	18.9	4½	114.3	400	120	yes		KH-53045	MHC00016
¾ 22.2	0.744	18.9	5½	139.7	400	120	yes		KH-53055	MHC00017
	0.744	18.9	6½	165.1	400	120	yes		KH-53065	MHC00018
	1.181	30.0	2½	66.7	480	240	yes		KH-826	MHC00043
	1.181	30.0	3⅞	28.6	480	240	yes		KH-82630	MHC00044
	1.181	30.0	3¾	92.1	550	240	yes		KH-82636	MHC00050
	1.181	30.0	4⅞	109.5	550	240	yes		KH-82640	MHC00051
	1.181	30.0	5⅞	134.9	650	240	yes		KH-82650	MHC00052
	1.181	30.0	6⅞	160.3	650	240	yes		KH-82660	MHC00053
	1.181	30.0	7⅞	185.7	650	240	yes		KH-82670	MHC00054
	1.105	28.1	8⅞	211.1	730	240	yes		KH-84380	MHC00064
1¼ 31.8	1.105	28.1	9⅞	236.5	730	240	yes		KH-84390	MHC00065
	1.105	28.1	10⅞	261.9	850	240	yes		KH-84310	MHC00066
	1.105	28.1	11⅞	287.3	850	240	yes		KH-85311	MHC00068
	1.105	28.1	12⅞	312.7	850	240	yes		KH-85312	MHC00069
	1.105	28.1	13⅞	338.1	850	240	yes		KH-85313	MHC00070
	1.105	28.1	14⅞	363.5	850	240	yes		KH-85314	MHC00071
	1.480	37.6	2½	63.5	750	240		yes	KH-1225	MHC00082
1.514	38.5	4½	114.3	1250	240		yes	KH-1245	MHC00083	
1.534	39.0	6½	165.1	1800	240		yes	KH-1265	MHC00084	
1.594	40.5	8½	215.9	2335	240		yes	KH-1285	MHC00086	
1.626	41.3	10½	266.7	2500	240		yes	KH-12105	MHC00087	



**Note:** All OEM Replacement Heaters have round cable, Type "C" galvanized armor cable lead wire protection and LO2 lead orientation (see page 5-4).

### Ordering Information

#### Standard Heaters

Order by Part Number for standard heaters listed in Tables on pages 5-6 through 5-9.

#### Custom Engineered/Manufactured Heaters

An electric heater can be very application specific; for sizes, ratings and terminations not listed, **TEMPCO** will design and manufacture a Mightyband heater to meet your requirements. **Standard lead time is 3 weeks.**

**Please Specify** the following:

- Watts
- Volts
- Coil I.D.
- Coil width (length)
- Distributed wattage if required
- Sheath material— 304 stainless steel or Incoloy® 600
- Sheath Diameter if necessary
- Length of internal nickel cold, or if a neck down design, length of cold section. See page 5-5.
- Thermocouple if required— Type J or K
- Thermocouple Junction—Grounded or Ungrounded. If ungrounded, specify location.
- Transition type: M1, M2, M3, A1, A2, A3, B1, B2, B3, C1, C2, C3, S1, S2 or S3. See page 5-5.
- Lead orientation: LO1, LO2, LO3, LO4, LO5, or LO6. See page 5-4.
- Lead length if other than 24"
- Supply a sketch or drawing.

**WARNING:** Cancer and Reproductive Harm - [www.P65Warnings.ca.gov](http://www.P65Warnings.ca.gov).



# Coil & Cable Heaters



## Mightyband™ (Square Cable)

### Mightyband™ Coil Heaters with Square/Rectangular MI Cable

TEMPCO offers a square sheathed, mineral insulated, coiled nozzle heater with a built-in-thermocouple. The unique feature of the 1/8" square sheath is a larger sheath contact area as compared to its round sheathed counterpart, allowing for faster start-up cycles. The ANSI Type J standard or optional Type K thermocouple normally has a grounded junction. However, an optional ungrounded junction is available. Heaters can be formed into a compact coiled nozzle heater supplying a full 360° of heat to the distributed wattage coil. The low mass of the heater allows quick response to both heating and cooling.



#### Specifications

- Resistance tolerance: ..... ±10%
- Wattage tolerance: ..... ±10%
- Maximum Wattage: ..... 720 watts (for 240 volt heaters)  
300 watts (for 120 volt heaters)
- Maximum operating temperature: ..... 1500°F (816°C)
- Maximum Watt density: ..... 134 watts/in<sup>2</sup> applied to nozzle
- Physical Dimensions: ..... 1/8" square  
(except non-heated tail section, which is 1/8" round)
- Length of non-heated section: ..... 1" to 6" (specify when ordering)
- Potting Adapter: ..... 5/16" O.D. × 1-1/2" long  
Standard Lead Length as specified in table below (if other than standard, specify)

#### Standard Features

- \* Standard lead wire construction is a fiberglass braided insulation with stainless steel overbraid suitable for 482°F (250°C). Optional constructions using Teflon® insulation or armor cable are available on request.
- \* The standard wire to M.I. cable transition area (potting adapter) is temperature rated to 450°F (232°C). High temperature 842°F (450°C) is optional.
- \* The ANSI Type J standard or optional Type K thermocouple junction can be grounded at the tip (the end farthest from transition area) or ungrounded anywhere along the length of the heater.
- \* Heaters can be supplied with optional stainless steel clamping straps, which provide additional circumferential clamping forces and protection of the heater coils from accidental damage.
- \* All Mightyband coil heaters are available with one (1) of six (6) different lead orientations (LO) as shown on Page 5-4. Other custom lead orientations can be manufactured to suit. Specify lead orientation when ordering.
- \* Can be supplied with optional grounding wire upon special request.

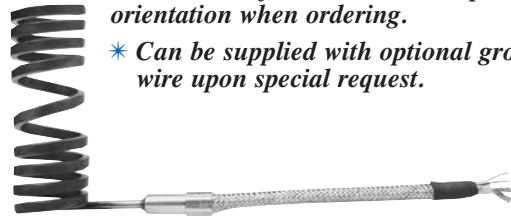

### Standard (Non-Stock) 1/8" Square Tempco-Pak Cable Heaters (Non-heated tail section is 1/8" round)

Standard Cable Heaters have 304 Stainless Steel Sheath

Coil I.D.		Closed Coil Width		Stretched Width		Built-In T/C	Voltage	Wattage	Standard Lead Length		Lead Protection	Lead Orientation	Part Number
in	mm	in	mm	in	mm				in	mm			
.500	12.7	2.00	50.8	2.5	63.5	yes	240	450	40	1016	C†	L01	MHC00116
.500	12.7	2.50	63.5	4.6	116.8	yes	240	300	48	1219	A†	L05	MHC00117
.750	19.1	1.25	31.8	—	—	yes	230	125	48	914	M†	L04	MHC00118
.750	19.1	1.25	31.8	—	—	yes	230	250	48	914	M†	L04	MHC00119
.750	19.1	1.25	31.8	1.5	38.1	yes	240	300	48	1219	S2	L05	MHC00120
.750	19.1	0.95	24.1	—	—	yes	240	250	72	1829	M1	L01	MHC00121
.968	24.6	0.95	24.1	—	—	yes	240	250	72	1829	M2	L01	MHC00122
.968	24.6	1.58	40.1	—	—	yes	240	300	72	1829	M2	L01	MHC00123

† Cement Potted Teflon® insulated SPC wire

#### Ordering Information

##### Standard Heaters

Order by Part number for standard heaters listed above for runnerless plastic injection molding, hot sprue bushings and nozzles.

If not otherwise specified, all Mightyband heaters are supplied with close wound coiling pattern, Type L01 lead orientation (see page 5-4), 24" of leads and 20" of stainless steel overbraid with Type J thermocouple. If longer leads are required, please specify.

##### Custom Engineered/Manufactured Heaters

An electric heater can be very application specific; for sizes, ratings and terminations not listed, TEMPCO will design and manufacture a Mightyband heater to meet your requirements. **Standard lead time is 3 weeks.**

Please Specify the following:

- Inside Diameter
- Width (Length)
- Specify width as closed or stretched
- Wattage
- Voltage
- Length of non-heated tail section
- Lead length
- Lead Orientation (see page 5-4)
- Lead Transition (see page 5-5)
- Lead protection (see page 5-5)
- Thermocouple Type—if required

**⚠ WARNING:** Cancer and Reproductive Harm - [www.P65Warnings.ca.gov](http://www.P65Warnings.ca.gov).

### Tempco Direct Replacement Heaters for OEM Hot Runner Systems Square & Rectangular Cable

#### Design Features

- \* 1/8" square 304 Stainless Steel M.I. cable
- \* Type J ungrounded thermocouple junction in the midsection of the coil heater
- \* 48" of leads and 44" of SS armored cable

Coil I.D.		Coil Width		Watts	Volts	OEM	TEMPCO
in	mm	in	mm			Part Number	Part Number
.500	12.7	4.625	117.5	300	120	SSTC-31	MHC00124
.500	12.7	4.625	117.5	300	240	SSTC-32	MHC00125
.500	12.7	2.500	63.5	450	240	SSTC-42	MHC00126



#### Design Features

- \* 1/8" square 304 Stainless Steel M.I. cable
- \* Type J ungrounded thermocouple junction in the midsection of the coil heater
- \* 48" of leads and 44" of SS armored cable

Coil I.D.		Coil Width		Watts	Volts	OEM	TEMPCO
in	mm	in	mm			Part Number	Part Number
.500	12.7	4.625	117.5	300	120	SSTC-31-90	MHC00127
.500	12.7	4.625	117.5	300	240	SSTC-32-90	MHC00128
.500	12.7	2.500	63.5	450	240	SSTC-42-90	MHC00129

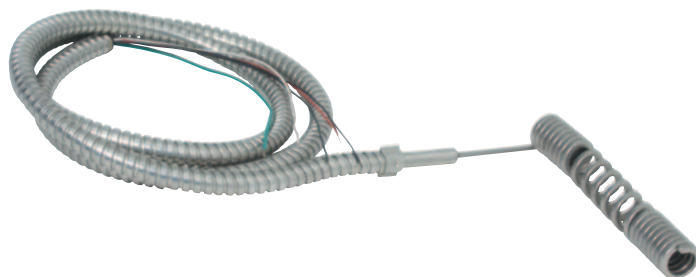

### Gated, Flow-Through Hot Sprue Bushing Heaters

#### Design Features

- \* .110" x .160" rectangular or 1/8" square 304 Stainless Steel M.I. cable
- \* No thermocouple
- \* 42" of leads and 38" of high temperature fiberglass sleeving

Coil I.D.		Coil Width		Watts	Volts	OEM	TEMPCO
in	mm	in	mm			Part Number	Part Number
1.250	31.8	2.625	66.7	800	240	SCH0001	HHC00001
1.250	31.8	1.750	44.5	600	240	SCH0002	HHC00002
.625	15.9	1.000	25.4	225	240	SCH0003	HHC00003
.750	19.1	1.750	44.5	315	240	SCH3142	HHC00004
.750	19.1	2.625	66.7	315	240	SCH3242	HHC00005



### Heated Nozzle Locator Heaters

#### Design Features

- \* 1/8" square 304 Stainless Steel M.I. cable
- \* Type J ungrounded thermocouple junction at tip of coil heater
- \* 36" of leads and 34" SS wire braid

Coil I.D.		Coil Width		Watts	Volts	OEM	TEMPCO
in	mm	in	mm			Part Number	Part Number
.500	12.7	1.450	36.8	250	240	SSTC-62-90	MHC00130
.500	12.7	1.950	49.5	250	240	SSTC-72-90	MHC00131

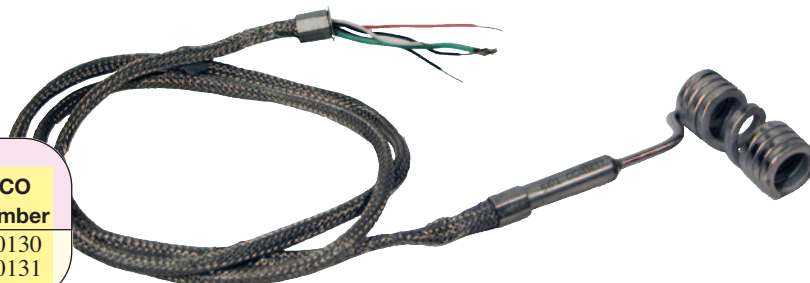

### OEM Replacement Heaters for Externally Heated Manifold Systems

#### Rectangular Cable Heaters



##### Design Features

- \* Systems with .250" diameter flow path nozzle assemblies
- \* Rectangular (0.110" x 0.160") 304 Stainless Steel M.I. cable
- \* Ungrounded Type J thermocouple
- \* 36" of leads and 34" of high temperature fiberglass sleeving

Coil I.D. in mm	Coil Width		Watts	Volts	OEM		TEMPCO	
	in	mm			Part Number	Part Number		
.625 15.9	2.000	50.8	300	240	SCH0081	MHC00132		
	2.500	63.5	350	240	SCH0082	MHC00133		
	3.000	76.2	400	240	SCH0083	MHC00134		
	3.500	88.9	425	240	SCH0084	MHC00135		
	4.000	101.6	500	240	SCH0085	MHC00136		
	5.000	127.0	500	240	SCH0086	MHC00137		
	6.000	152.4	550	240	SCH0087	MHC00138		

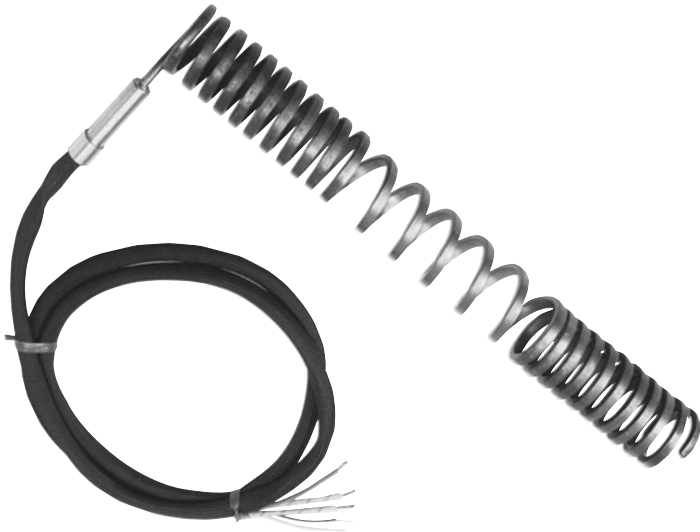

##### Design Features

- \* Systems with .375" diameter flow path nozzle assemblies
- \* Rectangular (0.110" x 0.160") 304 Stainless Steel M.I. cable
- \* Ungrounded Type J thermocouple
- \* 36" of leads and 34" of high temperature fiberglass sleeving

Coil I.D. in mm	Coil Width		Watts	Volts	OEM		TEMPCO	
	in	mm			Part Number	Part Number		
.875 22.2	2.125	54.0	400	240	SCH0088	MHC00139		
	2.625	66.7	450	240	SCH0089	MHC00140		
	3.125	79.4	550	240	SCH0090	MHC00141		
	3.625	92.1	700	240	SCH0091	MHC00142		
	4.125	104.8	800	240	SCH0092	MHC00143		
	5.125	130.2	900	240	SCH0093	MHC00144		
	6.125	155.6	1000	240	SCH0094	MHC00145		
	7.125	181.0	1100	240	SCH0095	MHC00146		

### Tempco Replacement Heaters and Thermocouples for OEM Hot Runner Nozzles

#### Design Features: Heater

- \* Systems with 0.024" nozzle gate diameter
- \* Rectangular (0.110" x 0.160") 304 Stainless Steel M.I. cable
- \* Separate thermocouple required (see table below for part number)
- \* 36" of leads and 34" of high temperature fiberglass sleeving

#### Design Features: Thermocouple

- \* Type J
- \* 1/16" OD, 304 Stainless Steel sheath
- \* See Section 14 page 14-44 for complete thermocouple details

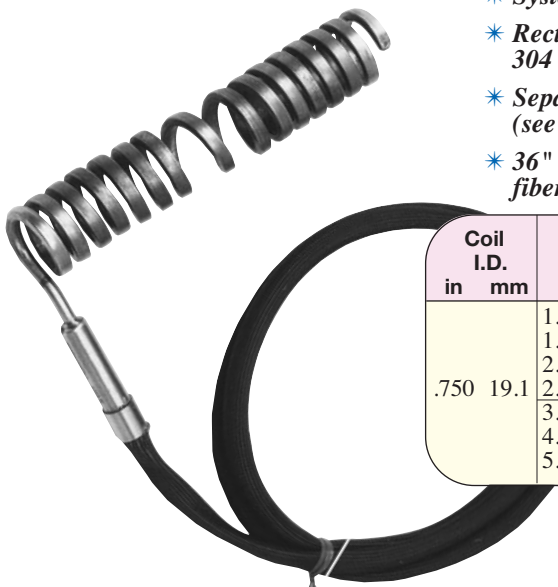

Coil I.D. in mm	Coil Width		Watts	Volts	Heater		Thermocouple	
	in	mm			OEM Part Number	TEMPCO Part Number	OEM Part Number	TEMPCO Part Number
.750 19.1	1.437	36.5	250	240	SCH0060	HHC00006	TCG0060	TCR00017
	1.937	49.2	300	240	SCH0061	HHC00007	TCG0061	TCR00018
	2.437	61.9	350	240	SCH0062	HHC00008	TCG0062	TCR00019
	2.937	74.6	400	240	SCH0063	HHC00009	TCG0063	TCR00020
	3.437	87.3	425	240	SCH0064	HHC00010	TCG0064	TCR00021
	4.437	112.7	500	240	SCH0065	HHC00011	TCG0065	TCR00022
	5.437	138.1	500	240	SCH0066	HHC00012	TCG0066	TCR00023

### Tempco Replacement Heaters for OEM Hot Runner Systems

#### Rectangular Cable Heaters

##### Sprue Bushing Heaters



##### Design Features

- \* 5/8" ID Coil
- \* Rectangular (0.110" x 0.160") 304 Stainless Steel M.I. cable
- \* 36" of leads and 32" of sleeving

Coil I.D. in mm	Coil Width		Watts	Volts	OEM	TEMPCO
	in	mm			Part Number	Part Number
.625 15.9	2.000	50.8	300	240	SF-620	MHC00267
	2.500	63.5	350	240	SF-625	MHC00268
	3.000	76.2	400	240	SF-630	MHC00269
	3.500	88.9	400	240	SF-635	MHC00270
	4.000	101.6	460	240	SF-640	MHC00271
	5.000	127.0	610	240	SF-650	MHC00273
	6.000	152.4	690	240	SF-660	MHC00274

##### Design Features

- \* 7/8" ID Coil
- \* Rectangular (0.110" x 0.160") 304 Stainless Steel M.I. cable
- \* 48" of leads and 44" of sleeving



Coil I.D. in mm	Coil Width		Watts	Volts	OEM	TEMPCO
	in	mm			Part Number	Part Number
.875 22.2	2.000	50.8	400	240	SF-820	MHC00275
	2.500	63.5	460	240	SF-825	MHC00276
	3.000	76.2	610	240	SF-830	MHC00277
	3.500	88.9	610	240	SF-835	MHC00278
	4.000	101.6	610	240	SF-840	MHC00279
	4.500	114.3	690	240	SF-845	MHC00280
	5.000	127.0	690	240	SF-850	MHC00281
	6.000	152.4	725	240	SF-860	MHC00282
	7.000	177.8	725	240	SF-870	MHC00283

#### Runnerless Mold Cartridge Heaters

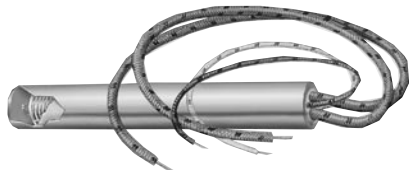

OEM Replacement  
Runnerless Molding  
Pennybottom Cartridge Heaters

See Section 2 pages 2-24 through 2-26



### Tempco Replacement Heaters for OEM Hot Runner Systems

#### Square Cable Heaters

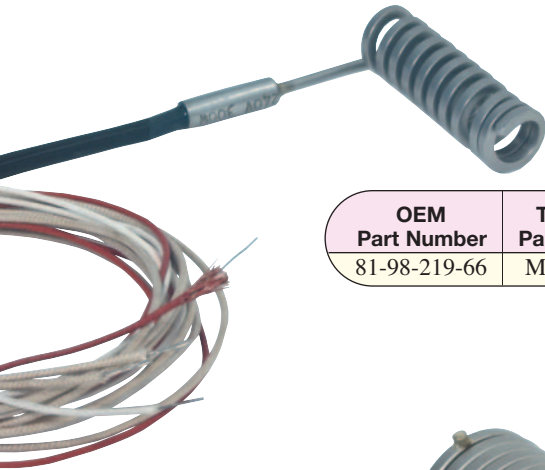

OEM Part Number	TEMPCO Part Number
81-98-219-66	MHC00457

#### Design Features

- \* 300 Watts, 240 Volts
- \* .100" square 304 Stainless Steel M.I. cable
- \* 3/8" ID x 2" stretched width
- \* Termination Type S1
- \* Lead Orientation LO1 with 3/4" reference cold length
- \* 48" of leads and 6" fiberglass sleeve
- \* Built-in Type J ungrounded thermocouple junction at tip of the heater
- \* Adapter Size: 1/4" O.D. x 7/8" long

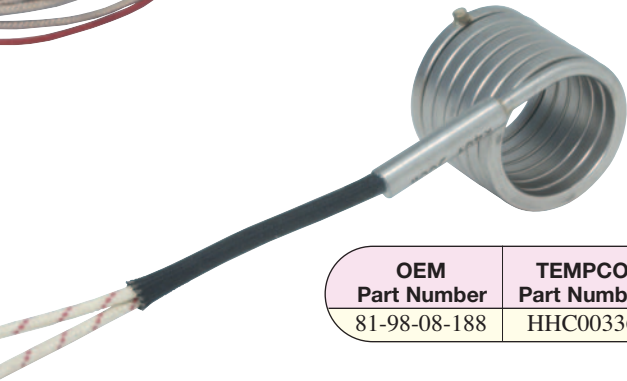

OEM Part Number	TEMPCO Part Number
81-98-08-188	HHC00336

#### Design Features

- \* 300 Watts, 240 Volts
- \* .132" square 304 Stainless Steel M.I. cable
- \* .997" ID x 1.12" nominal closed width
- \* Termination Type S1
- \* Lead Orientation LO1 with zero reference length and 1" cold tail length
- \* 10 feet of leads and 2" fiberglass sleeve
- \* Adapter Size: 1/4" O.D. x 1" long



OEM Part Number	TEMPCO Part Number
81-98-06-182	HHC00337

#### Design Features

- \* 200 Watts, 240 Volts
- \* .132" square 304 Stainless Steel M.I. cable
- \* .747" ID x 1" nominal closed width
- \* Termination Type S1
- \* Lead Orientation LO1 with zero reference length and 1" cold tail length
- \* 10 feet of leads and 2" fiberglass sleeve
- \* Adapter Size: 1/4" O.D. x 1" long

### Tubular Hot Runner Mold Heaters

SEE PAGE 10-13 IN THE TUBULAR HEATER SECTION.

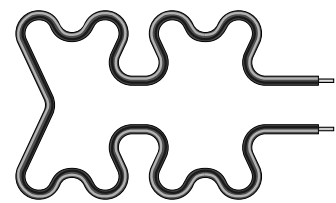
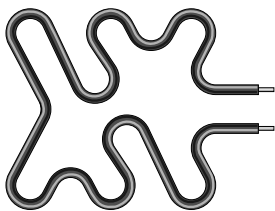



### OEM Replacement Oxygen Analyzer Heaters

#### Oxygen Analyzer Heaters (Westinghouse Probes)

##### Design Features

- \* Inconel® 600 Seamless Nickel Alloy Sheath Material for Process temperatures up to 1400°F (760°C)
- \* Minimum 99.4% purity compacted MgO Insulation Material
- \* 300 Series Stainless Steel Potting Adapter filled with Stycast epoxy for 500°F continuous use
- \* Standard heater lengths are 13", 18", 36" and 72" long. Longer length heaters such as 108" and 144" are also available.

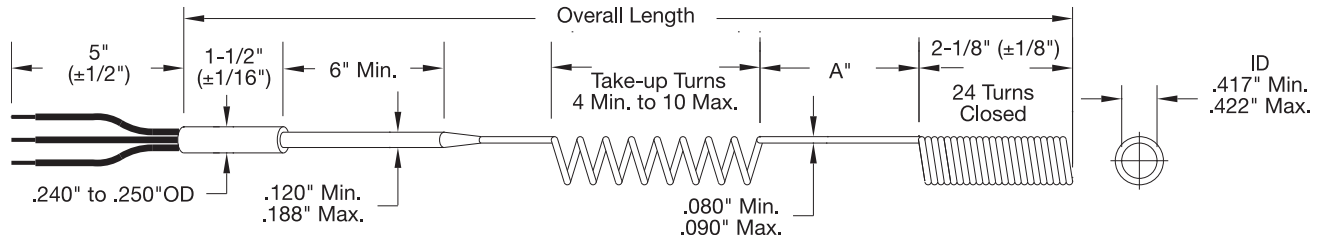

"OA" Length		"A" Length		Watts	Volts	OEM Part Number	TEMPCO Part Number
in	mm	in	mm				
13.0	330	0	0	340	115	263C303HO-6	HHF00009*
18.5	470	4	102	340	115	263C303HO-1	HHF00004
36.5	927	4	102	340	115	263C303HO-2	HHF00005
72.5	1842	4	102	340	115	263C303HO-3	HHF00006

**Lead Wires:** Teflon® insulated 600 Volt 18 ga. Nickel or Silver Plated Copper Wire (Stranded with Black or Brown)

**Grounding Wire:** 18 ga. Nickel or Silver Plated Copper, Stranded with Green or Purple Teflon® insulation/600 Volt Rated



**Note:** \*Part Number HHF00009 does not have a straight length section "A." The .080"/.090" diameter heater cable is coiled to .417"/.422" ID all the way to the neck down and stretched except for the front 24 turns of coils.

#### Oxygen Analyzer Heaters (Enotec Probes)

##### Design Features

- \* Inconel® 600 Seamless Nickel Alloy Sheath Material for Process temperatures up to 1400°F (760°C)
- \* Minimum 99.4% purity compacted MgO Insulation Material
- \* 300 Series Stainless Steel Potting Adapter filled with Stycast epoxy for 500°F continuous use
- \* Standard heater lengths are 13", 18", 36" and 72" long.

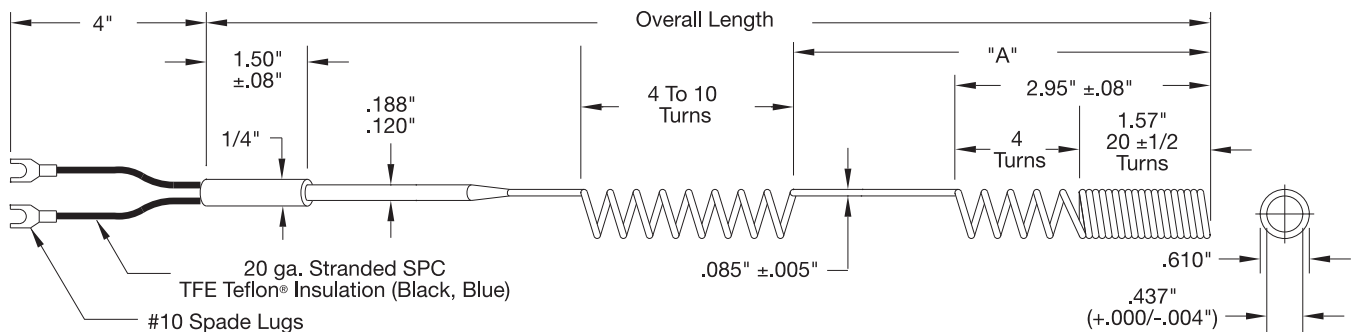

"OA" Length		"A" Length		Watts	Volts	OEM Part Number	TEMPCO Part Number
in	mm	in	mm				
13.15	334	4.23	107	340	115	HEI-132X	HHC00304
18.27	464	8.07	205	340	115	HEI-2001	HHC00199
36.50	927	8.07	205	340	115	HEI-2002	HHC00200
72.80	1849	8.07	205	340	115	HEI-2003	HHC00303

**Lead Wires:** Teflon® insulated 20 ga. Stranded Silver Plated Copper Wire (color coded one black and one blue)

**Termination:** #10 Uninsulated Spade Lug

#### Oxygen Analyzer Heaters with .153" Diameter Cable

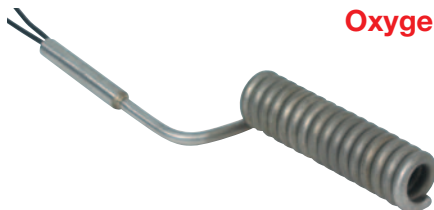

Tempco can also supply oxygen analyzer heaters for 240V, 520W with 0.153" diameter Inconel® 600 sheath, 0.394" ID x 2.75" coil width, with overall lengths of 6.29", 13.18", 17.12", 23.41", 32.86", 43.10", 62.39" and 80.11". Consult Tempco with your requirements – we welcome your inquiries.