



Recommendations for Improving the Life of Hi-Density Cartridge Heaters

Tempco Hi-Density Cartridge Heaters have been widely used in many demanding and diverse applications since 1972. The commonly used basic applications are platen, plastic mold and die heating, liquid immersion and air heating.



Note: Selection of the wrong termination for a particular application is the primary reason for all heater failures. However, failure to consider other important criteria can also have a negative effect on the life of the heater. To get the best performance and assure long life, it is important to carefully evaluate the following factors.

Operating Temperature

Operating temperature of a heater is a major factor in determining the life expectancy of a heating element. The heater life depends on the actual temperature of the resistance wire within the heater and not on the process operating temperature. The graph in Fig. 1 demonstrates the proper relationship between operating temperature and watt density; the higher the operating temperature, the lower the maximum recommended watt density.

Heater Watt Density

Cartridge heater watt density is defined as the wattage dissipated per square inch of the heated sheath surface. For a particular application a heater's watt density governs internal resistance wire temperature, which determines the outer sheath temperature. These factors are critical to the proper heating of the application and to the life expectancy of the heater. Special construction features that promote excellent heat transfer permit Hi-Density Cartridge Heaters to operate at higher watt densities while maintaining the lowest possible resistance wire temperatures of any style cartridge heater.

Heater watt density (w/in^2) is calculated using the following formula:

$$\text{Watt Density} = \frac{\text{Heater wattage}}{\text{Heated length} \times \text{Heater diameter} \times 3.1416}$$

Heated length is the overall length of the heater minus any unheated (cold) sections. Standard Type N, Hi-Density cartridge heaters have 3/8" at the lead end and 1/4" at the disc end unheated. This would mean a 6" long heater would have 5-3/8" effective heated length. Unheated sections vary with type of heater termination. For descriptions of terminations and options, see pages 2-39 through 2-60.

The graph in Fig. 1 shows the maximum recommended watt density for Hi-Density Cartridge Heaters when used in a steel platen. Watt density limitations for various materials are given in the engineering section of this catalog. For liquid immersion heaters the maximum watt density depends on the type of liquid being heated. The more viscous, or thicker the liquid, the lower the maximum watt density. Higher watt density can cause the liquid to carbonize and accumulate on the heater sheath, which will cause premature heater failure. It is advisable to use heaters that have watt densities below the maximum recommended watt density to get the longest heater life. If the actual heater watt density is close to the maximum recommended watt density, you can correct the problem by:

1. Increasing the number, diameter and length of heaters.
2. Lowering the total wattage; however, this may increase the heat-up time.
3. Obtaining tighter fit (see Fig. 2 — Determining Fit).

A Hi-Density cartridge heater designed at the maximum recommended watt density allows the smallest heater to be used to obtain the required wattage with good service life. All things being equal, using a lower watt density heater will typically provide optimized service life.

FIG. 1 Recommended Watt Density for Heating Metal Parts

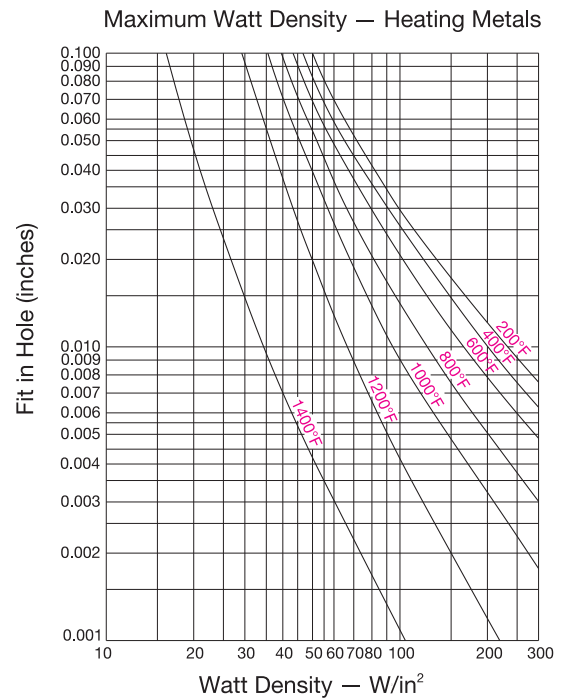

The graph shows the recommended maximum watt density for Tempco Hi-Density cartridge heaters at different operating temperatures and fit, when the heater is installed in an oxidized mild steel block. The thermocouple is located 1/2" from the heater. When heating other materials, the data needs to be extrapolated based on the thermal conductivity of the material. Consult Tempco with your requirements.

FIG. 2 Determining Fit

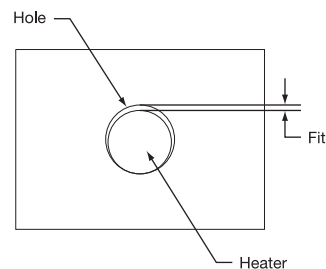

CONTINUED



Hi-Density

Recommendations for Improving the Life of Hi-Density Cartridge Heaters

Continued from previous page...

Determining Fit

When heating a platen, mold, die or hot runner probe with Hi-Density Cartridge Heaters inserted into drilled holes, fit is an important factor in determining the life expectancy of the heater. Fit is the difference between the minimum diameter of the cartridge heater and the maximum diameter of the hole. Unheated sections on a Hi-Density cartridge may be smaller in diameter due to swaging. To determine fit, use the smallest diameter on the heated length only.

Example: A 3/8" nominal OD Hi-Density cartridge heater has an actual diameter of .371" \pm .002, which translates to a minimum diameter of .369". If used in a .376" \pm .002 hole, the fit would be .009" (.378" - .369" = .009").

When medium watt density heaters (less than 60 watts per square inch) are used in low temperature applications (less than 600°F [315°C]) general purpose drills are commonly used to drill holes. The typical hole size may be .003" to .008" over the drill size. For higher watt density and/or higher temperature applications, we recommend that the holes are drilled and reamed for the tightest possible fit. In applications where precise temperature control and heat transfer properties are required, Hi-Density cartridge heaters can be centerless ground to \pm .0005".

Although a tighter fit is desirable to efficiently transfer heat and to get long heater life, a looser fit will aid in installing and removing heaters, especially long heaters. We recommend that you apply Tempco's BNS anti-seize cartridge heater coating as it will improve heat transfer and will make the removal of heaters easier.

The graph in Fig 1. (page 2-5) shows the effect of fit in determining the maximum recommended watt density on a steel platen. As it is indicated in the graph, the tighter the fit, the higher the maximum recommended watt density.

Temperature Control and Location of Temperature Sensing Device

In order to better control the heater temperature and hence the resistance wire temperature, use of an appropriate temperature control and the proximity of the heater to the sensor is very important. The graph in Fig. 1 (page 2-5) shows the effect of operating temperature in determining the maximum recommended watt density on a steel platen where the sensor is located 1/2" from the heater. Higher watt density heaters can generate heat faster than the surrounding area's ability to dissipate heat. This creates a thermal lag between the heater and the sensor. The closer the sensor to the heater, the better you can control the heater temperature. By keeping the sensor further from the heater, temperature gradients of several hundred degrees can be observed in many applications, especially during initial start-up and heavy thermal cycling. Although the set operating temperature may be low, the heater may be running at a very high temperature. This is a common cause of heater failure. This can be minimized using time proportional and PID functions of the temperature controllers. See Section 13 for temperature controllers and Section 14 for thermocouples and sensors.

Power Control

Power control methods affect the life expectancy of heating elements. In general, although economical, on-off controls increase thermal fatigue and oxidation rate on heating elements by causing wide temperature swings of the internal heating element. Silicon Controlled Rectifiers (SCRs), Mercury Relays and Solid State Power Controls can increase the life expectancy of heating elements by reducing the temperature swings of the internal heating element. See Section 13 for power controls.

Common Causes of Cartridge Heater Failures

Contamination

Contamination is a major cause of heater failure. Moisture, hydraulic oils, and melted plastic are the most common contaminants that are seen on failed heaters. Since the magnesium oxide insulation in a Hi-Density heater is hygroscopic in nature, moisture is easily absorbed into the heater and typically results in premature heater failure. Moisture absorption during machine washdown or cleanup also is a frequent problem. These contaminants, which are electrically conductive, will short out the heater. Most probably, the failures will be at the lead end of the heater and in some cases can split or blow a hole on the heater sheath. The disc end of a Hi-Density cartridge heater is welded shut with a stainless steel disc.

Generally, contaminants enter the heater through the lead end of the heater. The high temperature lead wires used on Hi-Density heaters have fiberglass or mica insulation. Oil and moisture can wick through the insulation on the lead wire into the heater. Tempco offers a wide variety of terminations to avoid this problem, including epoxy seals, Teflon® seals, convoluted cables, welded end discs, Teflon® insulated lead wires and SJO cable. However, there are temperature limitations on many of these terminations.



Note: If you should encounter premature cartridge heater failure, consult Tempco. Our team of professionals will have the solution to your problem.

Excessive Flexing of Leads

Tempco Hi-Density heaters use flexible grade A nickel stranded lead wires with fiberglass or mica insulation. On certain terminations the lead wires are connected externally to solid nickel conductor pins. In applications where there is excessive movement or vibration, the solid pins could break due to fatigue. A simple solution is to give enough slack on the leads to minimize the stress on the solid pins or provide an internal lead wire connection within the heater. Tempco also offers strain relief brackets and springs to prevent this problem.

Where heater leads can wear out by abrasion due to excessive flexing of the leads, Tempco offers several abrasion resistant terminations. See pages 2-41 through 2-47.

Lack of Heat Sink

Hi-Density heaters are designed with minimum unheated (cold) sections. If the heated sections project from the platen or mold, these sections will get extremely hot due to lack of heat transfer. This will lead to premature heater failure. Tempco can manufacture heaters with cold sections anywhere along the length of the heater to prevent overheating of the heater sheath.

When a Hi-Density heater is used as a liquid immersion heater, make sure the heater's sheath length is completely immersed in the liquid. The heater lead end should not be immersed in liquid, since most of the lead end seals are only moisture resistant, not moisture proof.



Recommendations for Improving the Life of Hi-Density Cartridge Heaters

High Operating Temperature

Tempco Hi-Density heaters are designed to operate at sheath temperatures up to 1400°F (760°C). When process temperatures approach the maximum heater sheath temperature, make sure the sheath temperature doesn't exceed its limitations. Location of the thermocouple and the type of temperature and power controls are factors that affect sheath temperature and potential overshoot conditions.

Although the heater is designed to run at temperatures up to 1400°F (760°C), heater lead wires and terminations are rated for much lower temperatures. Care should be taken to make sure that the heater lead end temperatures do not exceed their limitations. Heaters can be made longer with unheated sections at the lead end to bring the lead end out of the high temperature area. Tempco can also provide you with a high temperature wiring harness, which can withstand temperatures up to 1400°F (760°C). See page 15-5 in the accessories section for details.



Note: As explained in the above paragraphs, the single major cause for cartridge heater failure is the selection of the wrong type of heater lead end termination for the specific application. To assist you in selecting the right termination type, pages 2-39 through 2-57 give detailed descriptions of over 40 terminations designed to solve many of the common application problems. If you need further assistance, consult Tempco.

High Wattage Rating

Heaters with very high wattage ratings can create temperature overshoots, uneven temperature distribution and high heater sheath temperatures, causing premature heater failure.

For liquid immersion heaters, maximum watt density depends on the type of liquid being heated. The heavier or thicker the liquid, the lower the maximum watt density. Higher watt density can cause the liquid to carbonize and accumulate on the heater sheath, which will cause premature heater failure.

Scale and Sludge Buildup

In liquid immersion applications, periodic cleaning of the heater sheath is necessary to remove any scale buildup on the sheath. Scale can accumulate on the sheath and cause the heater to overheat and fail. When used to heat liquid in a tank, be sure to clean any sludge from the bottom of the tank. A heater sheath covered with sludge will overheat and fail.

Important Installation Considerations

- For closest fit and best heat transfer, use reamed holes.
- When possible, drill holes through the object being heated. This will make heater removal easier.
- When using an anti-seize coating like Tempco's BNS spray or paste, **do not apply** over lead wires or any other current carrying conductors.
- When using insulated tape or sleeving, check to make sure it is rated for the temperature of the application. Lower temperature rated materials can contain an adhesive or binder that can carbonize and become electrically conductive.
- When using heaters near their maximum recommended watt density, it is recommended that the temperature sensing probes be at maximum 1/2" from the heater sheath.
- Lead wires should not be located in the hole containing the cartridge heater during operation. This may cause the lead wires to be exposed to temperatures above their rated temperature.
- When used in a vacuum application, make sure the lead end of the heater is outside the vacuum. If the lead has to be in the vacuum, consult Tempco for specific recommendations.
- Many applications will subject a heater's electrical terminations to one or more of the following potentially damaging conditions:
 - Moisture
 - Oil and other contaminants
 - Flexing
 - Abrasion
 - High temperature



Note: To protect the heater from damage in these harsh environments, Tempco has a wide selection of terminations and options available. See pages 2-39 through 2-60 for details.

BNS Anti-Seize Cartridge Heater Coating

This high temperature, electrically insulating and thermally conductive coating will minimize oxidation and improve heat transfer from heater to the object being heated.

Brush a thin layer of paste or spray lightly over the cartridge heater prior to inserting the heater into a hole.



Do not apply over lead wires or other bare current carrying conductors, since the water in the paste and spray can cause an electrical short circuit.



13 oz.
Aerosol spray can
Part Number:
CML00010

- * Temperature Range 1562°F (850°C)
- * High Heat Transfer



4 oz.
Paste w/brush applicator top
Part Number: CML00020

- * Temperature Range 1562°F (850°C)
- * High Heat Transfer

Note: Formulated to assist in the removal of cartridge heaters.

All Items Available from Stock

