



Universal 2000

Construction Characteristics

The Universal 2000 Radiant Heater stands apart from all other similar products. Its rugged construction, enhanced design features and flexibility in installation allow it to be used in applications requiring a single unit or to be used as modules creating various configurations for process radiant heating systems.

Universal 2000 Radiant Heaters are available in a full range of standard construction variations, physical dimensions and electrical ratings. They are also available in custom engineered/manufactured units up to 132" (3353 mm) for series TRH1, 4 and 6. TRH3 and 5 series units are available up to 120" (3048 mm) lengths. Special electrical ratings, single end wiring, dual voltage, multiple heat designs, and optional fast response Quartz heater options (TRH1 & 2 NEMA1 units only), along with pre-wired units using flexible/rigid conduit or SJO cord/plug can be custom designed to fit your application.

Design Features

- * Direct retrofit to existing applications
- * Rugged anodized extruded aluminum housing
- * Polished aluminum reflector (replaceable)
- * Incoloy® sheath tubular heaters (replaceable)
- * Element Support brackets (replaceable)
- * Sliding mounting bolts (replaceable)
- * Dual internal wireways for single end wiring
- * Ground terminal lug
- * Slots for heat shield on side of housing for between units
- * Convenient field wiring
- * Made to order

Typical Installations

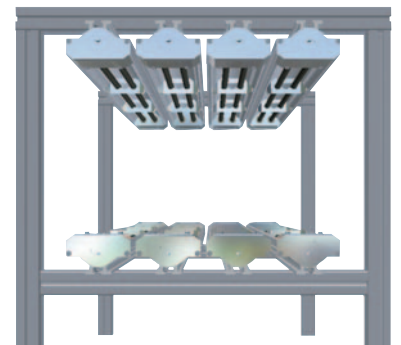
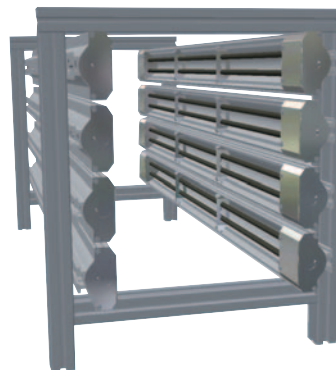
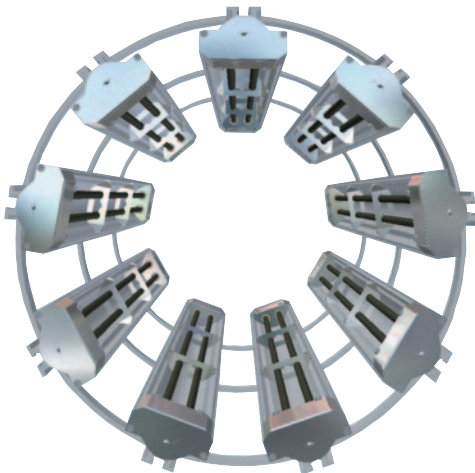
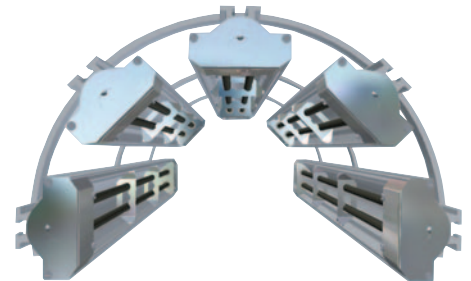
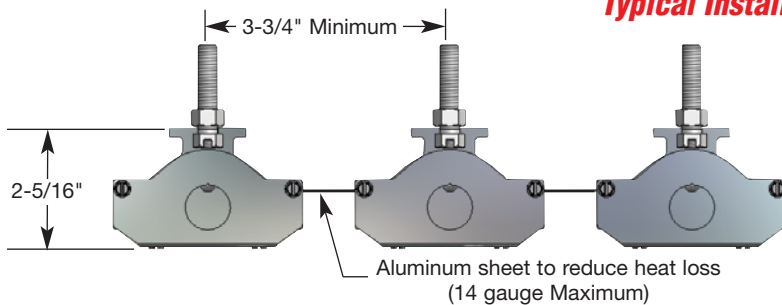

Ordering Information

Catalog Heaters

Part Numbers in red are in stock for immediate delivery. Non-Stock Part Numbers are standard designs.

Custom Engineered/Manufactured Heaters

Understanding that an electric heater can be very application specific, for sizes and ratings not listed, Tempco can manufacture a Tubular Radiant Heater to meet your requirements. **Standard lead time is 4 weeks.**

Please Specify the following:

- Overall Housing Length
- Wattage and Voltage
- Termination Features
- Wiring Options (Single or Double Ended)
- Series Construction Style

⚠ WARNING: Cancer and Reproductive Harm - www.P65Warnings.ca.gov.

(800) 323-6859 • Email: sales@tempco.com



Installation Recommendations

Installation Recommendations

- Sliding mounting bolts (1-3/4" long, 3/8-16 thread) slide along the length of the aluminum housing for mounting the heater to common structural framing materials, creating multiple heater installations accommodating flat, rectangular, polygonal, cylindrical or any other shape arrays.
Minimum distance of 3-3/4" on center for heaters mounted side-by-side. Do not exceed 42" between sliding mounting bolts.
- To reduce heat losses, heat deflector shields up to 14 gauge thick are recommended between heaters. Fiber insulation can also be placed behind the heater housing.
- In applications where water or solvents are being evaporated, proper ventilation is required to expel vapors or fumes.
- Standard NEMA 1 electrical enclosures located at opposite ends of the heater housing with standard 7/8" diameter knock-outs and a 1/2" NPT conduit threaded opening out the top of the housing facilitate single or double end wiring. Heaters with NEMA 3-4 boxes have dual 1/2" trade size hubs oriented 90° to each other. Openings accept standard electrical fittings.
- Hold the tubular heater terminal tabs with pliers when tightening the screws to ensure secure electrical connections. Use only high temperature hook-up lead wire and nickel-plated steel or monel lugs — Available from Tempco; see page 7-23 and Section 15.



Notes: Electrical wiring should be done by a qualified electrician with full knowledge of the installation and in accordance with local codes and the National Electrical Code.

High temperature hook-up wire and terminal lugs are available from stock. See page 7-23 and Section 15.

Maintenance

- Never perform any type of service prior to disconnecting all electrical power to the heater installation.**
- To maintain reflector efficiency, clean periodically with mild soap and water. Do not use alkali or other strong cleaners. They will dull the aluminum reflector finish.
- Replacement of elements, support brackets and reflectors.** (A) Remove terminal enclosure covers. (B) Disconnect power wires from element terminals. (C) Snap out support brackets. (D) Remove elements and old reflectors from front of unit. When replacing elements, reflectors should be replaced. Install new reflectors by snapping edges into housing grooves and reassemble other parts in reverse order.

Replacement parts are available from stock; see pages 7-86 and 7-87.



Wiring Hints – Wire selection depends on the requirements of the installation.

Wire Temperature Rating for inside the heater housing should be 482°F (250°C) or higher depending on the installation.

Voltage Rating should be equal to the operating voltage of the installation.

Wire Conductors should be nickel, nickel plated copper or nickel clad copper.

Do not use silver plated or unplated copper wire conductors.

Amperage Rating (wire gauge) should be 12 gauge for units drawing over 20 Amps of current. Use 14 gauge for units drawing under 20 Amps of current.

TRH1 (page 7-76) Standard Double-End Wiring

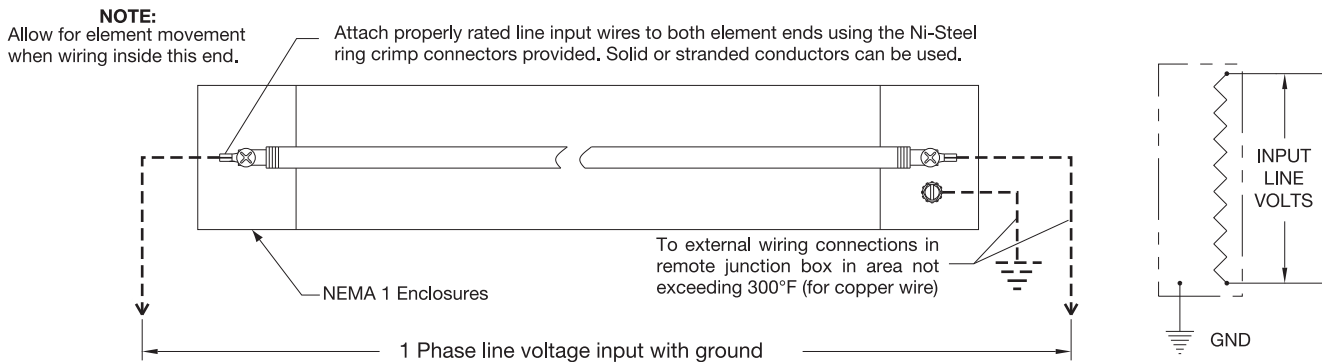

TRH1 (page 7-76) Optional Single End-Wiring

