

## Bulb and Capillary Thermostats

### Thermostat Styles and Selection

#### Construction Characteristics

This type of control operates by expansion and contraction of a liquid in response to temperature change. Liquid contained within the sensing bulb and capillary flexes a diaphragm,

causing the opening and closing of a snap-action switch. For heating applications the contacts are normally closed and open on temperature rise. See Page 13-77 for typical wiring diagrams.



**Style A**  
Single-Pole Thermostat

- \* General purpose thermostat recommended for most applications.
- \* Capable of controlling loads from 120V/30A up to 480V/20A

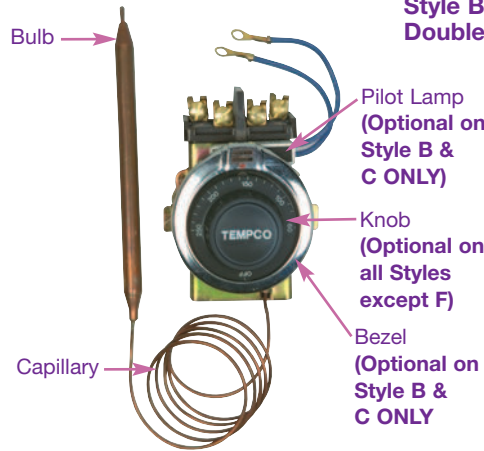

**Style B**  
Double-Pole Thermostat

- \* Recommended for directly controlling high wattage loads due to its heavy duty contacts.
- \* Capable of controlling loads up to 30 Amps at 277 VAC and 10 Amps at 480 VAC

#### Thermostat Electrical Ratings: Normally Closed Contacts, Open on Temperature Rise – Adjustable

Stock Items Are Shown In RED

Control Type	Style	Temp Range °F	Ampacity at Line Voltage				Bulb Dia. in	Bulb Length in	Capillary Length in	Terminals	Thermostat Part Number	Optional Thermostat Parts			Instruction Sheet P/N
			120V	240V	277V	480V						Knob	Bezel	Pilot Lamp	
SPST	A	60–250	30	30	30	—	0.27	6.00	12	#10 screw	TST-101-137	TST-104-103	n/a	n/a	IDP-119-102
		60–250	30	30	30	—	0.38	4.63	48	#10 screw	TST-101-131	TST-104-103	n/a	n/a	IDP-119-102
		70–245	30	30	15	15	0.25	5.50	12	#10 screw	TST-101-130	Included	n/a	n/a	IDP-119-102
		150–550	30	30	30	—	0.31	5.00	48	#10 screw	TST-101-132	TST-104-109	n/a	n/a	IDP-119-102
		150–560	30	30	30	20	0.33	3.70	12	#10 screw	TST-101-113	TST-104-109	n/a	n/a	IDP-119-102
		200–400	30	30	30	20	0.31	5.00	36	#10 screw	TST-101-121	TST-104-112	n/a	n/a	IDP-119-102
DPST	B	30–110	30	30	30	10	0.38	6.31	36	#10 screw	TST-110-101	TST-104-110	TST-111-101	EHD-109-103	IDP-119-105
		60–250	30	30	30	10	0.38	3.88	18	#10 screw	TST-110-124	TST-104-103	TST-111-101	EHD-109-103	IDP-119-105
		60–250	30	30	30	10	0.38	3.88	24	#10 screw	TST-110-125	TST-104-103	TST-111-101	EHD-109-103	IDP-119-105
		60–250	30	30	30	10	0.38	3.88	36	#10 screw	TST-110-126	TST-104-103	TST-111-101	EHD-109-103	IDP-119-105
		60–250	30	30	30	10	0.38	3.88	60	#10 screw	TST-110-102	TST-104-103	TST-111-101	EHD-109-103	IDP-119-105
		60–250	30	30	30	10	0.38	4.5	156	#10 screw	TST-110-118	TST-104-103	TST-111-101	EHD-109-103	IDP-119-105
		100–550	30	30	30	10	0.38	3.13	24	#10 screw	TST-110-117	TST-104-104	TST-111-101	EHD-109-103	IDP-119-105
		100–550	30	30	30	10	0.38	3.88	48	#10 screw	TST-110-103	TST-104-104	TST-111-101	EHD-109-103	IDP-119-105



- NOTES:**
- Knobs, Bezels and Pilot Lamps are optional and must be ordered separately from the thermostat.
  - Knob TST-104-119 graduated in °C (15-120) is available as an alternate for the standard TST-104-103 knob graduated in °F (60-250).
  - For Thermostat Enclosures refer to page 13-79.

### Thermostat Style A (Single Pole—Single Throw)

Typical circuit when voltage and/or line current does not exceed thermostat ratings

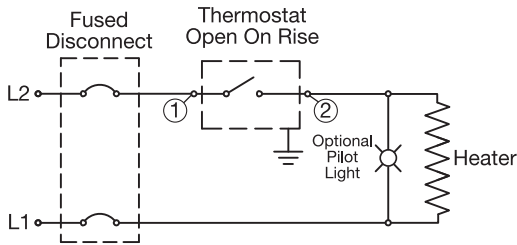

1Ø or 3Ø circuit if line voltage and/or current exceeds thermostat rating

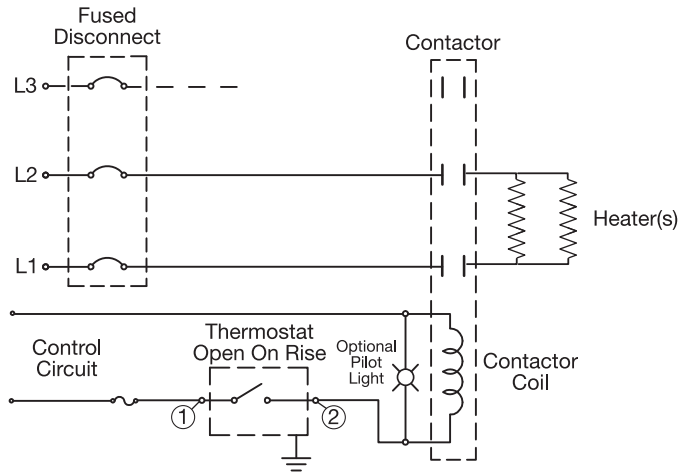

### Thermostat Style B (Double Pole—Single Throw)

Typical circuit when voltage and/or line current does not exceed thermostat ratings

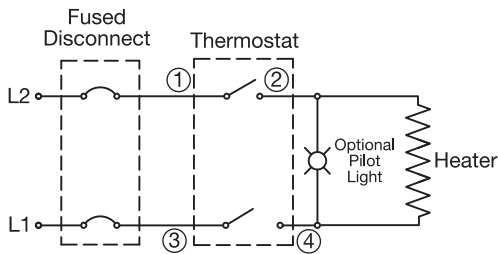

1Ø or 3Ø circuit if line voltage and/or current exceeds thermostat rating

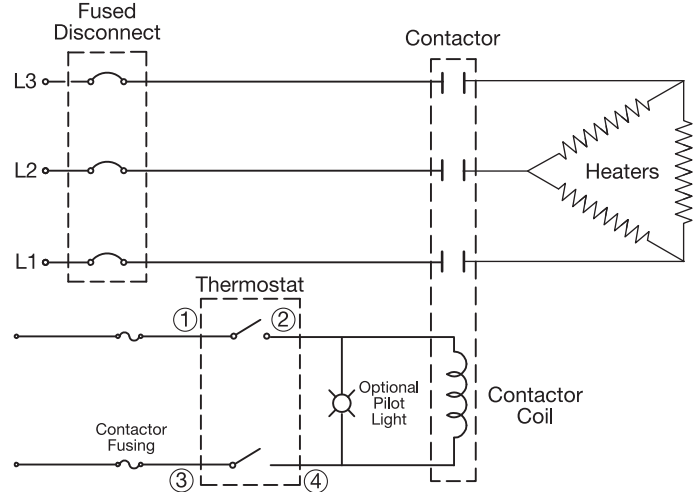

### Stock Thermostat Kits

Double-Pole Thermostat Kits include the following components:

Part Number TSTR-1008 with Style B Thermostat	
TST-110-103	Thermostat with 100 to 550°F Range
TST-104-104	Knob
EHD-109-103	Pilot lamp
TST-111-101	Bezel

Part Number TSTR-1009 with Style B Thermostat	
TST-110-102	Thermostat with 60 to 250°F Range
TST-104-103	Knob
EHD-109-103	Pilot lamp
TST-111-101	Bezel

**NOTE:** Double-Pole Thermostat Kits can also be installed separately from the heater in housing HSGR-1004 shown on page 13-79.

## Bulb & Capillary Thermostats

### Thermostat Styles and Selection

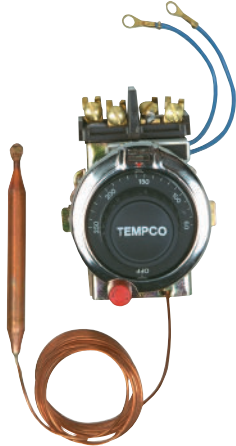

#### Style C Double-Pole Thermostat

- \* Secondary high limit circuit with manual reset
- \* High limit tracks 25°F above setpoint temperature
- \* High limit latches open until manual reset is pushed in the event that temperature exceeds 25°F above setpoint
- \* Capable of controlling loads up to 30 Amps at 277 VAC



#### Style D Single-Pole Thermostat

- \* General purpose thermostat recommended for most applications
- \* Capable of controlling loads up to 25 Amps at 240 VAC

Thermostat Electrical Ratings: Normally Closed Contacts, Open on Temperature Rise – Adjustable

Stock Items Are Shown In **RED**

Control Type	Style	Temp Range °F	Ampacity at Line Voltage				Bulb Dia. in	Bulb Length in	Capillary Length in	Terminals	Thermostat Part Number	Optional Thermostat Parts			Instruction Sheet P/N
			120V	240V	277V	480V						Knob	Bezel	Pilot Lamp	
DPST	C	60–250	30	30	30	—	0.38	4.50	18	#10 screw	TST-110-127	TST-104-103	TST-111-102	EHD-109-103	IDP-119-106
		60–250	30	30	30	—	0.38	4.50	24	#10 screw	TST-110-128	TST-104-103	TST-111-102	EHD-109-103	IDP-119-106
		60–250	30	30	30	—	0.38	4.50	36	#10 screw	TST-110-129	TST-104-103	TST-111-102	EHD-109-103	IDP-119-106
		60–250	30	30	30	—	0.38	4.50	72	#10 screw	TST-110-113	TST-104-103	TST-111-102	EHD-109-103	IDP-119-106
SPST	D	20–120	25	25	—	—	0.26	4.15	24	6" leads	TST-101-109	TST-104-105	n/a	n/a	IDP-119-101
		40–107	25	25	—	—	0.27	5.88	6	6" leads	TST-101-119	TST-104-102	n/a	n/a	IDP-119-101
		47–107	25	25	—	—	0.32	2.85	8	6" leads	TST-101-106	TST-104-102	n/a	n/a	IDP-119-101
		55–115	25	25	—	—	0.26	3.70	42	6" leads	TST-101-118	TST-104-102	n/a	n/a	IDP-119-101
		60–180	22	22	18	—	0.28	4.20	6	6" leads	TST-101-105	screw adj.	n/a	n/a	IDP-119-101
SPDT	D	60–250	25	25	—	—	0.28	3.00	12	6" leads	TST-101-101	TST-104-101	n/a	n/a	IDP-119-101
		60–250	25	25	22	—	0.27	4.10	12	#10 screw	TST-101-116	TST-104-114	n/a	n/a	IDP-119-103

#### NOTES:

- Knobs, Bezels and Pilot Lamps are optional and must be ordered separately from the thermostat.
- Knob **TST-104-119** graduated in °C (15-120) is available as an alternate for the standard TST-104-103 knob graduated in °F (60-250).
- Knob **TST-104-105** is a plain pointer knob, not calibrated for the range.
- Knob **TST-104-102** is printed with 4 through 10, not calibrated for the range.
- For Thermostat Enclosures refer to page 13-79.

#### Thermostat Style C (Double Pole—Single Throw) with Reset

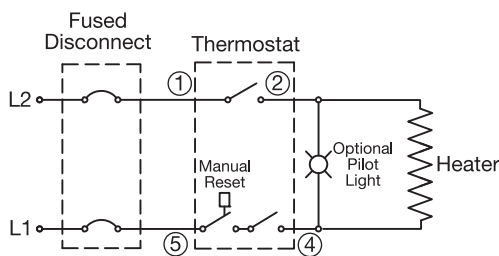

Typical circuit when voltage and/or line current does not exceed thermostat ratings

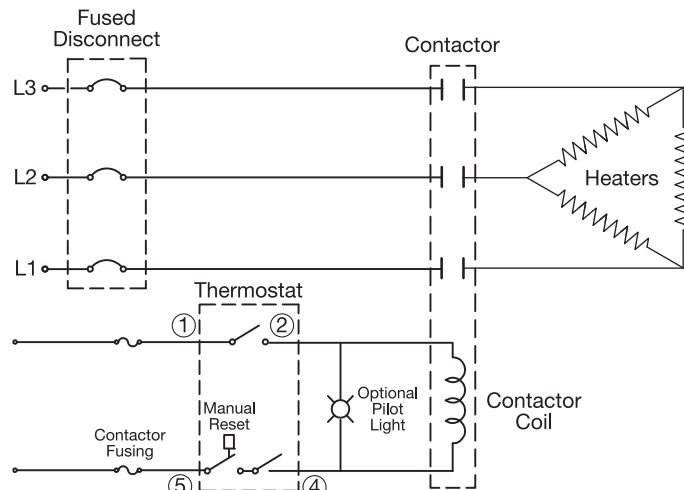

1Ø or 3Ø circuit if line voltage and/or current exceeds thermostat rating

### Thermostat Style D (Single Pole—Single Throw)

Typical circuit when voltage and/or line current does not exceed thermostat ratings

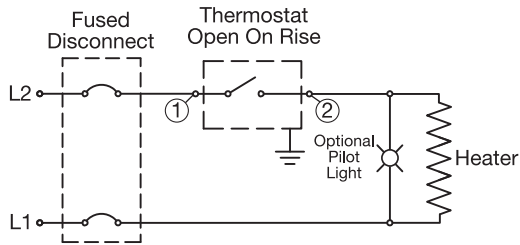

1Ø or 3Ø circuit if line voltage and/or current exceeds thermostat rating

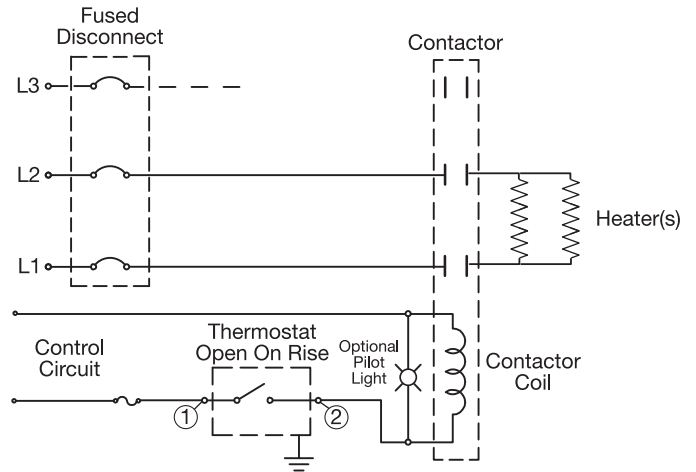

### Thermostat Style D (Single Pole—Double Throw)

Typical circuit when voltage and/or line current does not exceed thermostat ratings

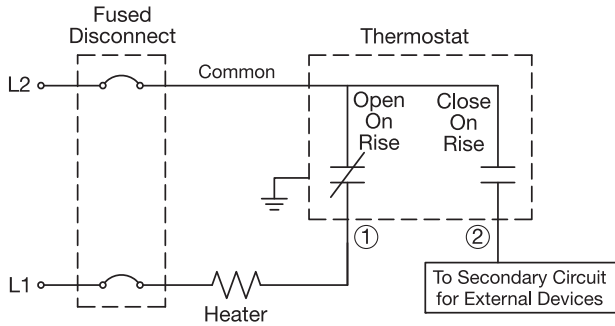

1Ø or 3Ø circuit if line voltage and/or current exceeds thermostat rating

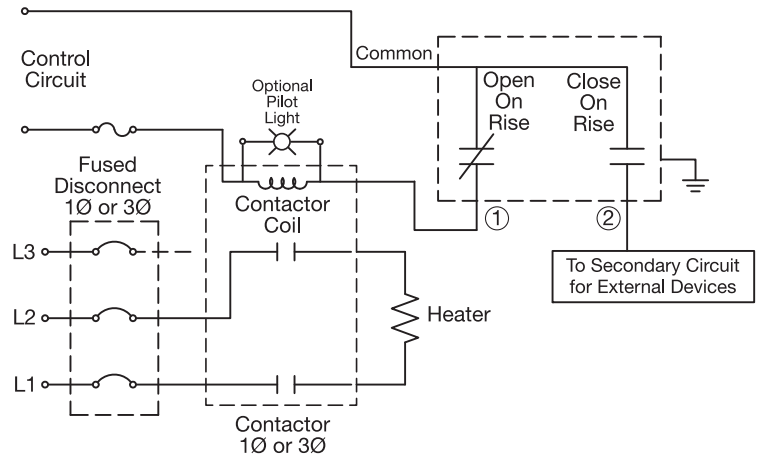

### Thermostat Installation Warnings & Recommendations

1. Do not use the thermostat as a power switch. Use some other means of disconnecting power to the heater for servicing.
2. Thermostats are not a fail-safe device. Use an approved high temperature limit control and/or pressure limit control for safe operation.
3. Avoid kinking or bending the capillary tube too sharply as this will alter the calibration and/or render the thermostat inoperable.
4. Excess capillary tube should be coiled neatly in junction box.
5. The capillary tube must never touch the thermostat contacts as this will create an electrical short capable of harming personnel and/or equipment.

### Stock Thermostat Enclosures

Thermostats and accessories sold separately



**NEMA 1 Enclosure**  
For Single-Pole Style A Thermostats

Size: 4-1/4"H x 3"W x 2"D with 3/4" trade size knockout  
Part Number: **HSGR-1003**



**NEMA 1 Enclosure**

For Double-Pole Thermostats  
Size: 6-1/2"H x 3-3/4"W x 2-1/2"D with 1/2" trade size knockout  
Used with Style B Thermostats and Thermostat Kits TSTR-1008 and TSTR-1009 shown on page 13-77.

Part Number: **HSGR-1004**

### Style F Temperature High Limit Switch with Manual Reset

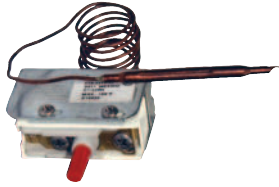

- \* General purpose high limit switch with manual reset
- \* Once fixed trip point is reached, the high limit switch will remain open until the manual reset button is pushed

**Thermostat Electrical Ratings: High Limit – Manual Reset, Normally Closed Contacts, Open on Temperature Rise at Fixed Temperature**

**Stock Items Are Shown In RED**

Control Type	Style	Temp Range °F	Ampacity at Line Voltage				Bulb Dia. in	Bulb Length in	Capillary Length in	Terminal	Thermostat Part Number	Instruction Sheet P/N
			120V	240V	277V	480V						
SPST	F1	118 ±3	30	30	20	20	0.32	3.00	12	#10 screw	TST-103-102	IDP-119-104
SPST	F1	118 ±4	30	30	20	20	0.27	3.35	6	#10 screw	<b>TST-103-109</b>	IDP-119-104
SPST	F1	125 ±2	30	30	20	20	0.25	3.35	36	#10 screw	<b>TST-103-108</b>	IDP-119-104
SPST	F1	165 ±15	30	30	20	20	0.21	2.63	30	#10 screw	TST-103-107	IDP-119-104
SPST	F1	200 ±5	30	30	20	20	0.31	4.00	12	#10 screw	TST-103-104	IDP-119-104
SPST	F1	350 ±8	30	30	20	20	0.25	3.50	36	#10 screw	<b>TST-103-103</b>	IDP-119-104
SPST	F2	420 ±15	30	30	30	30	0.25	4.85	30	#10 screw	TST-103-110	IDP-119-104
SPST	F1	572 ±15	30	30	30	20	0.21	2.63	30	#10 screw	TST-103-106	IDP-119-104

**NOTES:** F2 style has a side vertical mounting bracket instead of #8 tapped holes for mounting. Refer to IDP-119-104 for mounting details.

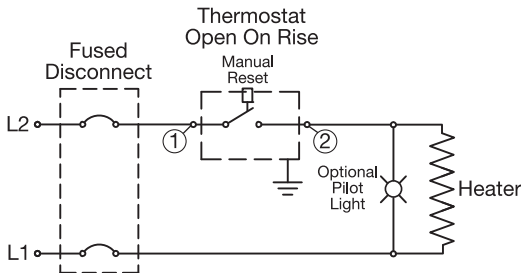

**Hi-Limit Thermostat Style F (Single Pole—Single Throw)**

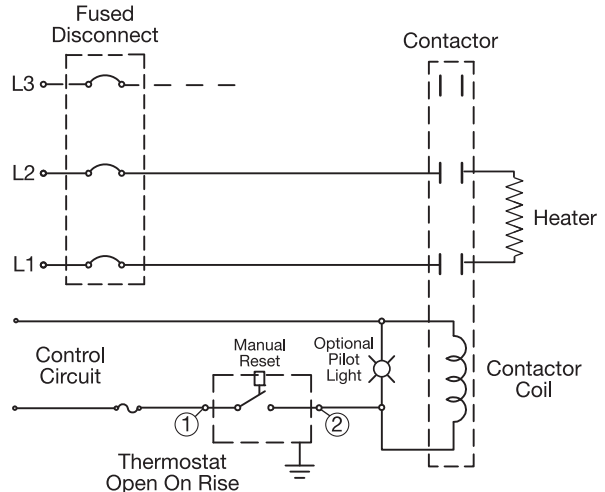

### Thermowells (Stainless Steel or Plain Steel)

Welded thermowells provide simple protection for bulb and capillary sensors.

They are supplied with a 1/2" NPT male thread for mounting and a 3/8" NPT internal thread that can be used with the stuffing box assembly to secure the capillary to the well. ID: 0.50", OD: 0.56" See pages 14-76 through 14-83 for thermowells manufactured from bar stock.

Immersed Length in mm	Part Number	
	Steel	Stainless Steel
12	*MPT-120-101	*MPT-121-101
18	MPT-120-102	MPT-121-102
24	MPT-120-103	MPT-121-103
36	MPT-120-104	MPT-121-104

An \* indicates a stock item.

### Stuffing Box Assembly

The Stuffing Box Assembly is used to seal the thermostat capillary when the sensing bulb (3/8" max. OD) is immersed directly in a liquid rather than in a thermowell. The Stuffing Box consists of six slotted washers used to compress a graphite packing into a 3/8" NPT male pipe thread fitting.

#### Assembly Instructions

Feed sensing bulb through hole in upper and lower fitting. Insert washers and packing into top cavity of lower fitting. Upper fitting then screws into lower fitting, creating the seal.

**Part Number: TST-109-101**





### Conduction Type Thermostats B2 Series — Surface Mounted

**Tempco Conduction Thermostats** do not use only a bonded bimetal strip. The contacts are opened and closed by the expansion and contraction of the base plate in conjunction with the thermal strip. Single pole, single throw contacts open with temperature rise, providing minimum overshoot, smaller cycling differential and faster response to heat load.

**Installation Note:** The heat-sensitive base plate of the thermostat must be mounted in full contact with the heated surface. This surface should be flat and smooth, and screws should be used for mounting.

Agency Approvals:  File Number E224645

#### Typical Applications

- ➔ Flat Irons
- ➔ Ironers
- ➔ Deep Fryers
- ➔ Roasters
- ➔ Solder Pots
- ➔ Vulcanizers
- ➔ Sealing Machines
- ➔ Sealing Irons
- ➔ Ovens
- ➔ Hot Plates
- ➔ Industrial and Laboratory Applications

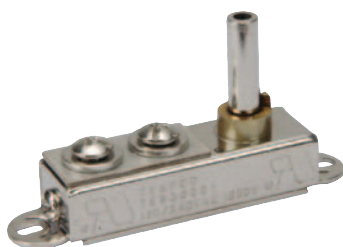

**Optional Knob**

**Part Number: TST-104-118**  
 Markings: 0-10  
 For 1/4" shaft, with set screw  
 Material: Phenolic  
 0.9" Diameter x 0.667" Height

#### Standard Models with Shaft

Designed for installation with the base plate in full contact with heated surface. Pre-drilled holes facilitate mounting.

Temperature Range °F (°C)	Amp Rating @ 120 VAC	Amp Rating @ 240 VAC	Overall Shaft Length	Part Number
50 to 525°F (10 to 274°C)	13.75	6.87	1.5"	TEB30001
50 to 425°F (10 to 218°C)	13.75	6.87	1.5"	TEB30002

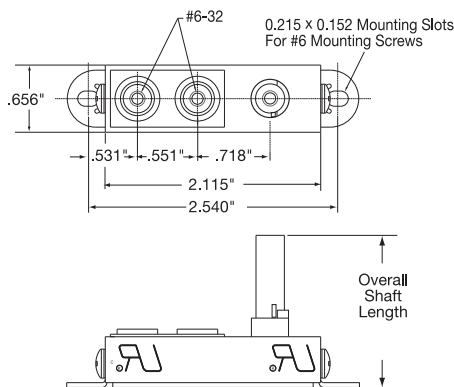
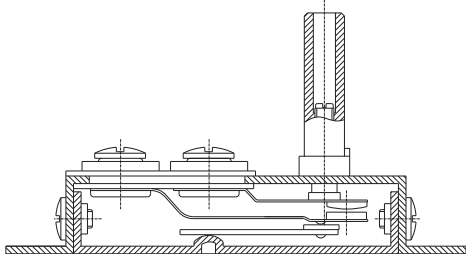
#### Specifications

**Voltage:** 120 VAC @ 13.75A / 240 VAC @ 6.87A  
**Wattage:** 1650  
**Temperature Tolerance:** ±5°F / 2.7°C  
**Operation Range:** 50 to 570°F (10 to 300°C)  
**Wiring:** Tapped for #6-32 screws (included)  
**Endurance:** 100,000 cycles

**Contact Tempco for your OEM requirements such as special range calibrations or shaft lengths.**



**Screwdriver Adjustment (optional preset calibration)**

Available with factory preset temperature calibration. This feature is optional—if required, specify temperature setting from 72°F (22°C) to 570°F (300°C).

The screw-adjust thermostat is offered in three temperature ranges:

Temperature Range °F (°C)	Pre-Set Tolerance	Amp Rating @ 120 VAC	Amp Rating @ 240 VAC	Part Number
50 to 249°F (10 to 121°C)	±10°F / 6°C	13.75	6.87	TEB32000
250 to 399°F (121 to 204°C)	±15°F / 8°C	13.75	6.87	TEB33000
400 to 570°F (204 to 300°C)	±20°F / 11°C	13.75	6.87	TEB34000

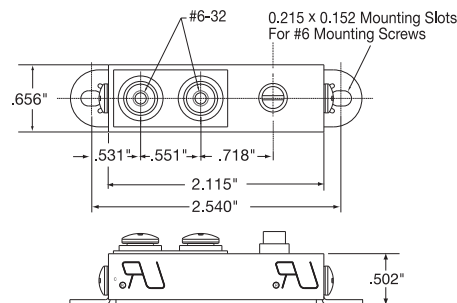

### Ordering Information

Choose the **Part Number** of the conduction thermostat that is correct for your application.

For pre-set TEB32XXX, TEB33XXX and TEB34XXX thermostats consult Tempco with your desired setpoint for a Part Number.

All Items Available from Stock

**⚠ WARNING:** Cancer and Reproductive Harm - [www.P65Warnings.ca.gov](http://www.P65Warnings.ca.gov).

**(800) 323-6859 • Email: [sales@tempco.com](mailto:sales@tempco.com)**

### Surface Mount 1/2" Disc Pre-Set Snap Action Thermostats

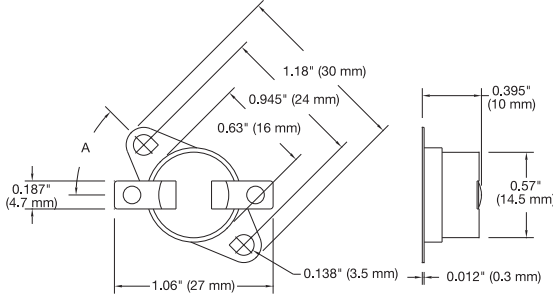

#### Typical Applications

- Vacuum Cleaners
- Food Service Equipment
- Fireplaces
- Hot Plates
- Laboratory Applications



#### Construction Characteristics

This line of highly reliable switches utilizes a temperature sensitive disc electrically isolated from the switch. Contacts will open when surface or ambient temperatures increase to the snap point of the calibrated bimetal disc. The entire switch assembly is enclosed in a dust-free housing. The thermostats under 350°F setpoint have a phenolic housing. The thermostats with a setpoint of 350° and over have a ceramic housing. The bimetal disc is retained by a metal heat-conducting end cap.

These thermostats are used in a variety of applications. They are produced in an ISO 9000 certified factory to insure safe and reliable operation. All models are 100% factory inspected for temperature, continuity and function.

#### Specifications

**Electrical Ratings Type S:** 125 VAC, 15 Amps, Resistive  
250 VAC, 8 Amps, Resistive  
100,000 Cycles

**Inductive Load Ratings:** 120 VAC, 5.8FLA, 34.8LRA  
240 VAC, 2.9FLA, 17.4LRA  
6,000 Cycles

**Operating Temp. Range:** 50 to 500°F (10 to 260°C)

**Environmental Temp.:** 32 to 350°F (0 to 177°C)

**Insulation Resistance:** 100M ohms or more (500 VDC megger)

**Circuit Resistance:** 50m ohms or less (initial value)

**Dielectric Strength:** 1,500 VAC / 1 minute

**Approvals:** UL, cUL, CSA, VDE, Demko

*All Items Available from Stock*

#### Standard Stock Surface Mount Disc Thermostat Temperature Ratings

Open °F	Close °F	Open °C	Close °C	Mounting	Terminals	Dim A	TEMPCO Part Number
50 ±5	32 ±10	10.0 ±2.8	0 ±5.6	Surface Mount	Solder Tab	45°	TST-112-105
60 ±5	40 ±7	15.6 ±2.8	4.4 ±3.9	Surface Mount	Solder Tab	45°	TST-112-106
80 ±5	50 ±9	26.7 ±2.8	10.0 ±5.0	Surface Mount	Vertical, 0.250 quick connect	90°	TST-112-107
95 ±5	77 ±9	35.0 ±2.8	25.0 ±5.0	Surface Mount	Horizontal, 0.250 quick connect	90°	TST-112-142
120 ±5	90 ±10	48.9 ±2.8	32.2 ±5.6	Surface Mount	Solder Tab	45°	TST-112-108
130 ±5	100 ±10	54.4 ±2.8	37.8 ±5.6	Surface Mount	Solder Tab	45°	TST-112-109
140 ±5	110 ±10	60.0 ±2.8	43.4 ±5.6	Surface Mount	Solder Tab	45°	TST-112-101
150 ±5	120 ±10	65.6 ±2.8	48.9 ±5.6	Surface Mount	Solder Tab	45°	TST-112-110
160 ±5	130 ±10	71.1 ±2.8	54.4 ±5.6	Surface Mount	Solder Tab	45°	TST-112-111
175 ±5	145 ±10	79.4 ±2.8	62.8 ±5.6	Surface Mount	Vertical, 0.250 quick connect	45°	TST-112-112
180 ±5	150 ±10	82.2 ±2.8	65.6 ±5.6	Surface Mount	Solder Tab	45°	TST-112-113
190 ±5	160 ±10	87.8 ±2.8	71.1 ±5.6	Surface Mount	Solder Tab	45°	TST-112-114
200 ±5	170 ±10	93.3 ±2.8	76.7 ±5.6	Surface Mount	Solder Tab	45°	TST-112-115
210 ±5	180 ±10	98.9 ±2.8	82.2 ±5.6	Surface Mount	Horizontal, 0.187 quick connect	45°	TST-112-116
230 ±7	200 ±10	110.0 ±3.9	93.3 ±5.6	Surface Mount	Vertical, 0.250 quick connect	90°	TST-112-117
250 ±7	220 ±10	121.1 ±3.9	104.4 ±5.6	Surface Mount	Solder Tab	45°	TST-112-118
300 ±7	220 ±14	148.9 ±3.9	104.4 ±7.8	Rotating Bracket	Vertical, 0.250 quick connect	N/A	TST-112-119
350 ±14	290 ±20	176.7 ±7.8	143.3 ±11.1	Rotating Bracket	Horizontal, 0.187 quick connect	N/A	TST-112-120
375 ±14	315 ±18	190.6 ±7.8	157.2 ±10.0	Rotating Bracket	Horizontal, 0.187 quick connect	N/A	TST-112-121
392 ±18	194 ±29	200.0 ±10.0	90.0 ±16.1	Rotating Bracket	Horizontal, 0.187 quick connect	N/A	TST-112-122
400 ±10	340 ±12	204.4 ±5.6	171.1 ±6.7	Rotating Bracket	Horizontal, 0.187 quick connect	N/A	TST-112-123
425 ±15	375 ±20	218.3 ±8.3	190.6 ±11.1	Rotating Bracket	Horizontal, 0.187 quick connect	N/A	TST-112-124
450 ±15	370 ±20	232.2 ±8.3	187.8 ±11.1	Rotating Bracket	Horizontal, 0.187 quick connect	N/A	TST-112-125
500 ±20	420 ±20	260.0 ±11.1	215.6 ±11.1	Rotating Bracket	Horizontal, 0.187 quick connect	N/A	TST-112-126

### High Limit Surface Mount Disc Thermostats with Manual Reset

#### Construction Characteristics

This line of highly reliable switches utilizes a snap-action bimetal disc electrically and thermally isolated from the switch. The contacts are normally closed and open on rise when surface or ambient temperature setpoint is reached. The circuit will remain open until the manual reset button is depressed at approximately 30% below its operating temperature. All models are 100% temperature tested and can be calibrated to your specification at the factory. Many popular settings are available from stock.

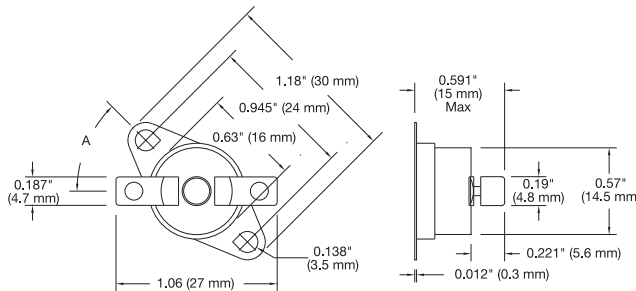

#### Specifications

- Electrical Ratings Type U:** 125 VAC, 15 Amps, Resistive  
250 VAC, 10 Amps, Resistive  
6,000 Cycles
- Inductive Load Ratings:** 120 VAC, 5.8FLA, 34.8LRA, 12 Amps  
250 VAC, 2.9FLA, 17.4LRA  
6,000 Cycles
- Operating Temp. Range:** 50 to 320°F (10 to 160°C)
- Differential:** 15 to 100°F (8 to 56°C)
- Environmental Temp.:** 32 to 350°F (0 to 177°C)
- Insulation Resistance:** 100M ohms or more (500 VDC megger)
- Circuit Resistance:** 50m ohms or less (initial value)
- Dielectric Strength:** 1,500 VAC / 1 minute
- Approvals:** UL, cUL, CSA

#### Typical Applications

- Vacuum Cleaners
- Food Service Equipment
- Fireplaces
- Hot Plates
- Laboratory Applications

#### Ordering Information

Choose the **Part Number** of the 1/2" Thermostat from the tables on pages 13-82 and 13-83 that match the needs for your application.

We also offer other styles of 1/2" Thermostats with alternate setpoints. Consult Tempco for availability.

**Standard lead time is stock to 3 weeks.**

#### Standard Stock High Limit Manual Reset Thermostats

Open °F	Open °C	Mounting	Terminals	Dim A	TEMPCO Part Number
150 ±10	65.6 ±5.6	Rotating Bracket	Vertical, 0.250 quick disconnect	N/A	TST-115-101
160 ±10	71.1 ±5.6	Surface Mount	Solder tabs	45°	TST-115-102
194 ±10	90.0 ±5.6	Surface Mount	Solder tabs	90°	TST-115-103
212 ±10	100.0 ±5.6	Rotating Bracket	Horizontal, 0.250 quick disconnect	N/A	TST-115-104
250 ±10	121.1 ±5.6	Surface Mount	Solder tabs	45°	TST-115-105
302 ±10	150.0 ±5.6	Surface Mount	Vertical, 0.250 quick disconnect	45°	TST-115-106
320 ±10	160.0 ±5.6	Surface Mount	Horizontal, 0.250 quick disconnect	45°	TST-115-107

Available from Stock



**Note:** "Rotating Bracket" mounting indicates that the mounting holes can be rotated vs. the solder tabs and for "Surface Mount" they are fixed.

**⚠ WARNING:** Cancer and Reproductive Harm - [www.P65Warnings.ca.gov](http://www.P65Warnings.ca.gov).

**(800) 323-6859 • Email: [sales@tempco.com](mailto:sales@tempco.com)**

### One Shot Thermal Cutoffs



#### Design Features

- \* *Low Cost*
- \* *Excellent Contact Rating*
- \* *Quick & Easy Installation*

#### Typical Applications

- *Personal Care*
- *Appliances*
- *Motors*

**Thermal cutoffs** are designed to provide upper limit temperature protection for many electronic products. Under normal operating temperature, the solid pellet compresses a spring which holds the star contact against the isolated lead. When a fault temperature is reached, the pellet melts and the circuit is opened permanently.

It is important to allow sufficient time to determine the proper and best location for a thermal cutoff. The location will affect the cutoff's ability to protect your product. Placement in the highest temperature area is usually best. Use a thermal cutoff that is higher than your target operating temperature, as a thermal cutoff is supposed to be a fail-safe to protect the system from catastrophic failure.

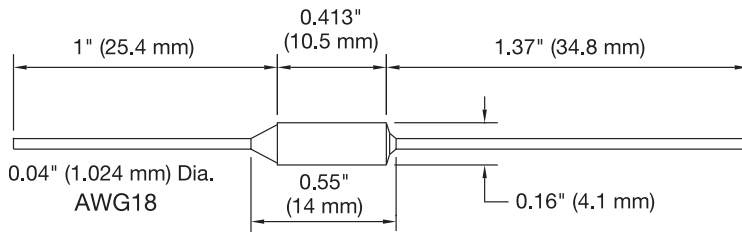

#### Specifications

**Electrical ratings:** 120/250 VAC, 10 Amps, Continuous duty  
120/250 VAC, 15 Amps, Interrupting current

**Temperature tolerance:** +0°C/-4°C  
(+0°F/-7°F)

**Approvals:** UL, CSA, VDE

#### Ordering Information

Choose the **Part Number** of the thermal cut-off that best meets the requirements on your application from the chart above.

**Standard lead time is stock to 3 weeks.**

#### Standard Stock Thermal Cutoff Temperature Ratings

Cutoff Temp. °F	°C	TEMPCO Part Number
151	66	TST-106-104
162	72	TST-106-110
170	77	TST-106-111
183	84	TST-106-112
196	91	TST-106-113
208	98	TST-106-114
219	104	TST-106-101
230	110	TST-106-106
250	121	TST-106-107 <sup>①</sup>
262	128	TST-106-109
286	141	TST-106-115
291	144	TST-106-116 <sup>②</sup>
306	152	TST-106-117
333	167	TST-106-105 <sup>①</sup>
363	184	TST-106-119
378	192	TST-106-120
421	216	TST-106-121 <sup>③</sup>
464	240	TST-106-122

**Agency Approvals:**  
UL, CSA, VDE

Exceptions as noted:

- ① No agency approvals
- ② UL and CSA approved only
- ③ VDE approved only

**⚠ WARNING:** Cancer and Reproductive Harm - [www.P65Warnings.ca.gov](http://www.P65Warnings.ca.gov).

### Differential Expansion Cartridge Type Thermostats

**Widely Used in Industrial, Scientific and Commercial Temperature Control Applications**

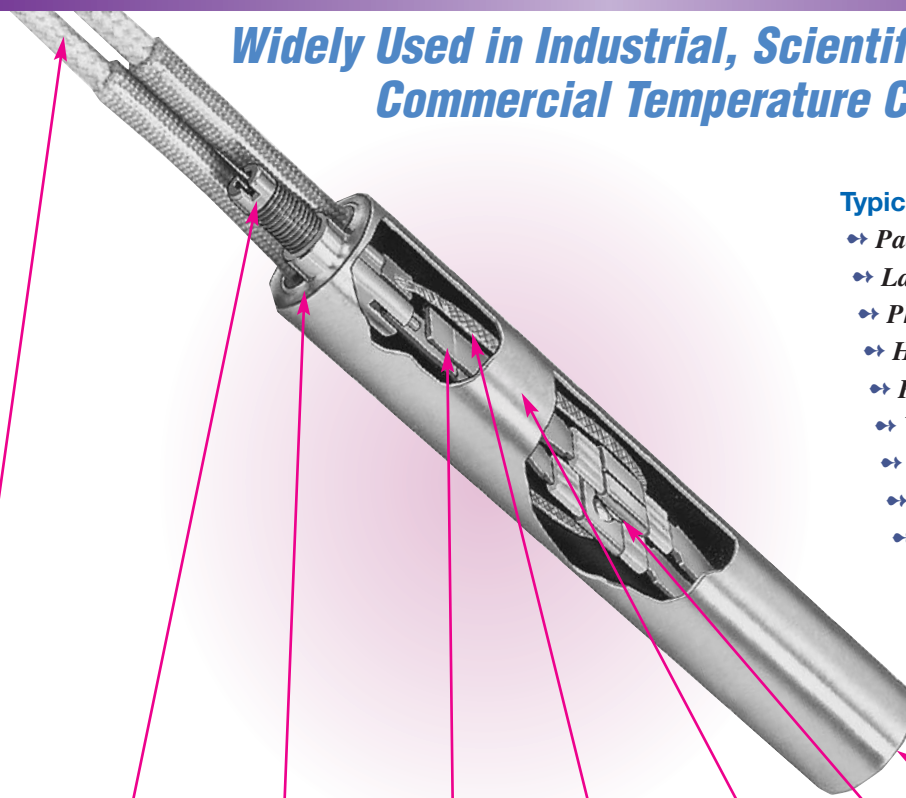

#### Typical Applications

- ✦ Packaging Machinery
- ✦ Laminating Equipment
- ✦ Photographic Processing
- ✦ Hot Stamping
- ✦ Plastic Processing Machines
- ✦ Vending Machines
- ✦ Food Service Equipment
- ✦ Medical & Dental Equipment
- ✦ Code Dating Equipment

#### Design Features

**A**

Flexible leads externally connected to terminal pins provide high pull strength, eliminating pulled out leads.

**B**

Setpoint adjustment allows the setting of the temperature required without transmitting force to the contact mechanism, which can interfere with the accuracy of the unit.

**C**

Terminals are embedded in fused glass, providing a seal and strain relief to eliminate lead tension that can interfere with the accuracy of the unit.

**D**

One-piece strut made from low expansion alloy is assembled under tension. The strut and contacts operate by slow make and break, responding to the smallest temperature changes, accounting for quick response and sensitivity to within  $\pm 1.0^{\circ}\text{F}$ .

**E**

Wire braid provides the flexibility required in order to withstand the expansion and contraction of the outer shell without interfering with the ability of the unit to handle the load capacity under maximum operating temperature.

**F**

The expanding shell is the heat sensing component and not just a housing, being responsive to the slightest temperature changes and leading the strut by an interval that varies with the range of temperature.

**G**

Silver alloy contacts mounted on a one-piece strut. They open and close by the expansion and contraction of the outer shell, instantaneously responding to temperature changes.

**H**

Heli-arc welded end disc provides a positive seal against moisture and other contaminants.

# Temperature Controllers



## Cartridge Type Thermostats

### Thermostatic Cartridge Type Temperature Controls

Tempco Thermostatic Temperature Controls are proven, simple, sensitive temperature controls with an adjustable setpoint. The sheath is a temperature sensor that responds to the tempera-

ture of its environment by expanding and contracting, thereby mechanically actuating a set of contacts within. Use to accurately control temperature on hundreds of applications.

### Specifications

#### Temperature Range:

1/4" dia. models: -100 to 500°F (-73 to 260°C)  
1/2" and 5/8" dia. models: -100 to 600°F (-73 to 315°C)

#### Tube Shell Diameters:

1/4" dia. model: 0.249" +.000/-.004" actual  
1/2" dia. model: 0.499" +.000/-.004" actual  
5/8" dia. model: 0.625" +.000/-.004" actual

**Contact Action:** Slow make and break

**External Materials:** 304 Stainless Steel

**Agency Approvals:**



#### Sensitivity:

1/4" dia. model: As low as 1°F depending on application  
1/2" and 5/8" dia. models: As low as 0.5°F depending on application

**Accuracy:** Dependent on application

#### Standard Termination:

1/4" dia. model: 8" long - #26 ga silver plated copper with Teflon® insulation  
1/2" dia. model: 8" long - #20 ga stranded nickel clad copper with fiberglass insulation  
5/8" dia. model: 8" long - #16 ga stranded nickel clad copper with fiberglass insulation

### Standard Stock Thermostatic Controls

Insert Dia.	Contact Length	Action on Temp. Rise	Electric Rating (Amp-Volts)	Part Number
5/8"	3 5/8"	Open (NC)	10A@120VAC, 5A@240VAC	TEV01500
		Close (NO)	2A-120 VDC	TEV01501
1/2"	2 1/2"	Open (NC)	5A@120VAC, 3A@240VAC	TEV01400
		Close (NO)	1A@120VDC	TEV01401
*1/4"	1 1/16"	Open (NC)	1A@120VAC	TEV01200
		Close (NO)	1A@120VAC	TEV01201
5/8"	3 7/16"	Open (NC)	10A@120VAC, 5A@240VAC	TEV02500
		Close (NO)	2A-120 VDC	TEV02501
1/2"	2 5/16"	Open (NC)	5A@120VAC, 3A@240VAC	TEV02400
5/8"	3"	Open (NC)	10A@120VAC, 5A@240VAC	TEV03500
		Close (NO)	2A-120 VDC	TEV03501
1/2"	2"	Open (NC)	5A@120VAC, 3A@240VAC	TEV03400
		Close (NO)	1A@120VDC	TEV03401
*1/4"	3/4"	Open (NC)	1A@120VAC	TEV03200
		Close (NO)	1A@120VAC	TEV03201
5/8"	3"	Open (NC)	10A@120VAC, 5A@240VAC	TEV04500
		Close (NO)	2A-120 VDC	TEV04501
1/2"	2"	Open (NC)	5A@120VAC, 3A@240VAC	TEV04400
		Close (NO)	1A@120VDC	TEV04401
*1/4"	3/4"	Open (NC)	1A@120VAC	TEV04200
		Close (NO)	1A@120VAC	TEV04201
5/8"	3 5/16"	Open (NC)	10A@120VAC, 5A@240VAC	TEV05500
		Close (NO)	2A-120 VDC	TEV05501
1/2"	2 5/16"	Open (NC)	5A@120VAC, 3A@240VAC	TEV05400
		Close (NO)	1A@120VDC	TEV05401
*1/4"	1 1/4"	Open (NC)	1A@120VAC	TEV05200
		Close (NO)	1A@120VAC	TEV05201

\*1/4" Thermostatic Controls have been discontinued and will no longer be available once stock has been depleted.

### Ordering Information

State part number and special features if required. For special Thermostatic Controls, consult Tempco.

- \* The 1/2" and 5/8" dia. models are UL recognized.
- \* The 5/8" dia. model is CSA certified.
- \* Factory pre-set temperature setpoint: specify temperature setpoint.
- \* Extra lead length: specify length required.
- \* Extended shell length, with sensitivity at the top or bottom: specify length required and sensitivity.

**⚠ WARNING:** Cancer and Reproductive Harm - [www.P65Warnings.ca.gov](http://www.P65Warnings.ca.gov).

### Design Features

- \* Flexible armor cable over leads: blockhead style B only. Specify length required.
- \* Moisture resistant seal.
- \* Moisture resistant or explosion resistant, N7, attached to a Type C coupling head thermostat; specify requirements.
- \* Ground wire attached to the shell; specify length required.

## SELECTION GUIDE

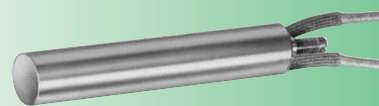

#### Type S Cartridge

Temperature controller for applications in metal, air, gas and many other mediums.

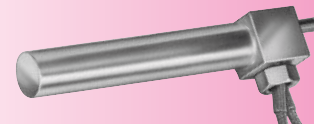

#### Type B Block Head

The block head style allows the thermostat to be mounted without the use of bushings.

Also excellent for making right-angle connections.



#### Type P Pipe Thread

Designed for mounting in tanks for temperature control of liquids or gases. A stainless steel bushing affords ease of mounting and a positive seal.

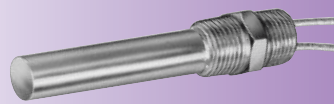

#### Type C Coupling Head

Designed to accept conduit or plumbing fittings to protect the screw and lead wires in adverse conditions.

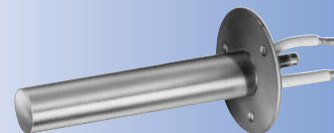

#### Type F Flange

Designed to mount directly to duct or oven wall for the sensing of air or gas temperatures.

*All Items Available from Stock*

### Dimensional Specifications

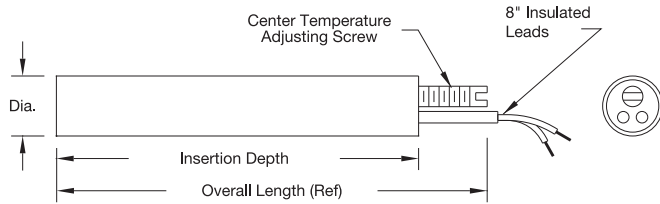

#### Type S — Cartridge Style

Diameter	Overall Length (Reference Only)	Insertion Depth
5/8"	4-3/8"	3-5/8"
1/2"	3-1/4"	2-1/2"
1/4"	1-5/8"	1-7/16"

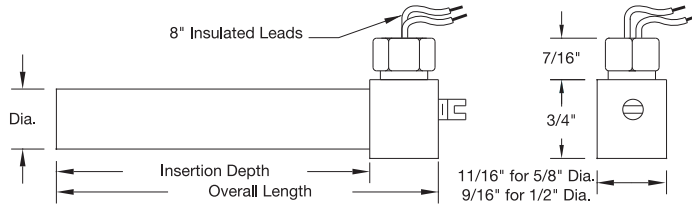

#### Type B — Block Head Style

Diameter	Overall Length	Insertion Depth	Block Thk.
5/8"	4-3/16"	3-7/16"	3/4"
1/2"	3-1/16"	2-5/16"	3/4"
1/4"	Not Available		

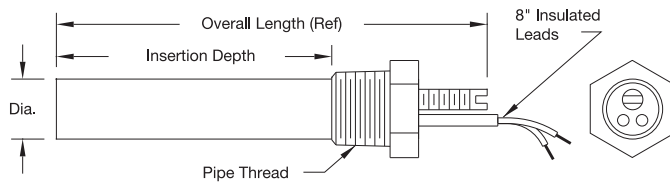

#### Type P — Pipe Thread

Diameter	Overall Length (Reference Only)	Insertion Depth	Pipe Thread
5/8"	4-3/8"	3"	1/2"-14 NPT
1/2"	3-1/4"	2"	3/8"-18 NPT
1/4"	1-5/8"	3/4"	1/8"-27 NPT

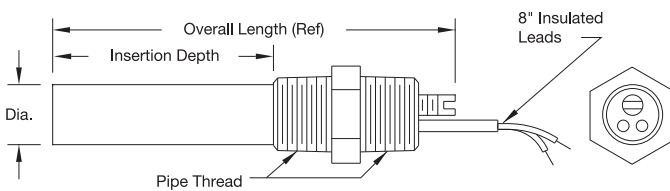

#### Type C — Coupling Head

Diameter	Overall Length (Reference Only)	Insertion Depth	Pipe Thread
5/8"	4-1/2"	3"	1/2"-14 NPT
1/2"	3-1/4"	2"	3/8"-18 NPT
1/4"	1-3/4"	3/4"	1/8"-27 NPT

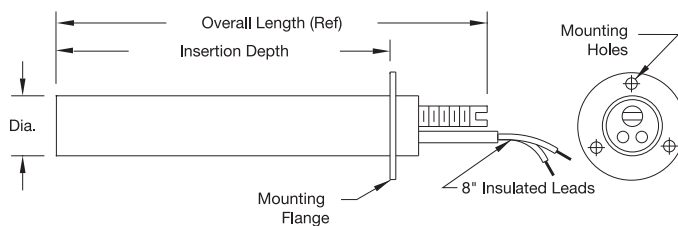

#### Type F — Flange

Diameter	Overall Length (Reference Only)	Insertion Depth	Flange Dia.	Mounting Holes (3)
5/8"	4-3/8"	3-5/16"	1-3/4"	.156" dia. on a 1.25" DBC
1/2"	3-1/4"	2-5/16"	1-1/2"	.156" dia. on a 1" DBC
1/4"	1-5/8"	1-1/4"	1"	.144" dia. on a 5/8" DBC

### Installation Guidelines and Observations

- Do not expose the thermostat to more than 100°F / 38°C above the setpoint temperature.
- On 1/2" and 5/8" diameter thermostats, do not turn the adjusting screw more than 7 revolutions in either direction from room temperature.
- On 1/4" diameter thermostats, do not turn the screw more than 1/4 revolution in either direction from room temperature without checking temperature setpoint.
- Removal of the adjusting screw may render the thermostat inoperative.
- System vibration can cause contact bounce. The addition of a capacitor will reduce the bouncing and overshooting. The recommended capacitor is 0.1 μF rated at 600VDC for 120 VAC applications and 1000VDC for 240 VAC applications. The capacitor should be attached parallel across the thermostat's leads.
- Optimum performance will result when the amperage load is half of the maximum rating.
- Do not attempt to seal the lead end with silicone materials such as caulking or grease.