

# TEMPCO Offers the Largest Selection of Quality Cast-In Heaters for Plastics Processing

Over 15,000 Existing Designs on File and Growing



## Single Source Advantage – From Beginning to End

Tempco has set industry standards as the leading manufacturer of Aluminum, Brass and Bronze Cast-In Heaters in a variety of standard designs and styles for the plastics processing industry.

However, we realize not every Cast-In Heater application can be solved by one of our standard products. Our solutions help our customers and create new opportunities for Tempco. It is our engineering talents and vast application knowledge that provide a winning combination for solving specific application problems with custom designed and manufactured Cast-In Heaters.

The design, engineering and manufacturing of Tempco Cast-In Heaters is done under one roof—administered by a team of experienced professionals with a vast knowledge in product design and proven foundry expertise, producing the best quality Cast-In Heaters money can buy.

**Computer Designed Tubular Heaters** manufactured under our rigid quality control standards are the heat source for the Cast-In Heater. They can be formed into endless configurations to accommodate any practical Cast-In Heater shape.

**Wood Pattern Shop** A full-service in-house wood pattern shop builds, modifies and maintains patterns.

**Foundry Capabilities** Tempco's modern foundry produces Low Pressure Permanent Mold, Tilt Pour Permanent Mold, and No-Bake Mold Sand Castings. Our team of professionals with years of practical experience provides the knowledge essential for producing quality cast-in heaters for the plastics processing industry.

Cast-In Heaters are produced in-house by a team of experts for unparalleled quality!

**SATISFACTION GUARANTEED!**

Tempco's Exclusive **Cool TO-THE Touch™** Heating & Air Cooling Shroud Systems for Extrusion Processing Can be found on pages 3-26 through 3-32

Consult us with your requirements. No one can do it better than Tempco – Let us prove it!

### Plastics Extrusion Processing

Our Cast-In Band Heaters have proven to be the most effective method for heating and cooling the barrels of extruders used in the plastics processing industry.

Tempco offers Cast-In Band Heaters with liquid or air cooling. Liquid cooling incorporates tubing cast in as part of the heater assembly, allowing water or heat transfer solutions to remove excess heat. Air cooling uses fins cast to the Outer Diameter surface of the band heater;

blowers and specially designed shrouds aid in heat removal.

Aluminum is the predominant alloy used for the Cast-In Heater. Copper-based alloys (Bronze and Brass) are used when the required operating temperatures exceed the maximum for Aluminum. Bronze or Brass are recommended for heated platens in molding presses as they can withstand a greater force of pressure per square inch than Aluminum.

#### Typical Plastics Processing Applications For Tempco's Cast-In Heaters

- ➔ Extruders
- ➔ Blow Molding
- ➔ Injection Molding
- ➔ Extrusion Die Heads
- ➔ Silk-Screening
- ➔ Laminating Equipment
- ➔ Heat Sealers
- ➔ Vacuum Forming
- ➔ Compression Molding
- ➔ Polymer Compounding

**When your needs call for Cast-In Heaters for Plastics Processing & you need them NOW!**  
**Look no further than Tempco – we have an extensive inventory.**  
**Custom manufactured with the best lead times in the Industry!**

## Are You Operating Your Extruders with Liquid Cooling?

If You Answer Yes –

Then You Are SO Ready for a

**TEMPCO**

**EXTREME  
MAKEOVER**

With Our Exclusive

**Cool to the Touch™**

Shroud Systems



*A 4-Zone  
Cool to the Touch  
Shroud System*

*Let Tempco's state-of-the-art technology convert your extruder's existing heating and cooling system from antiquated, inefficient and costly to modern, highly efficient, and cost-effective.*

*We invite you to energize your extrusion business with Cool to the Touch. It can take your profits to the next level.*

### **The Challenge**

We understand that choosing to make a change can be challenging and full of "What-If's?" Not to worry – Tempco warrants the performance of our systems. Our expert team will be with you every step of the conversion to help you select the ideal system for your extrusion lines.

**Cool to the Touch** is a fully integrated system that offers powerful functionality, user-friendly installation and operation, customizable features and other benefits you simply will not find in any existing extruder heating and cooling system.

These highly engineered products are designed for durability and trouble-free operating performance.

It can very well be the most important step you take when you purchase a new extruder or rebuild existing equipment.

*Experience the benefits and advantages offered by upgrading to Cool TO-THE Touch Shroud Systems.*

*Take your extrusion operation to the next level of technology with Tempco at your side.*

**There is nothing to lose, except. . .**

*The entire closed loop recirculating system which includes: chiller, heat exchanger, heat transfer fluid, and all associated piping and electrical components.*



**Let's Not Forget About This!!**

**Think about all the great changes ahead for your business – when you no longer have to babysit your unreliable, maintenance nightmare on your extruder heating and cooling system.**

### *It's a Reality – Extreme Makeover for Extruders Is Finally Here! Take Advantage of It If You Are . . .*

#### **Purchasing a New Extruder**

*Specify to your machine builder to install one of Tempco's exclusive high-efficiency Cool to the Touch heating and air cooling systems.*

**SMALL INVESTMENT**

**BIG RETURN**

#### **Retrofitting**

*Outdated air cooled systems can be retrofitted with Tempco's efficient air cooled shroud designs without replacing your existing heaters.*

**Add Value to Your Extrusion Process**

#### **Rebuilding**

*An outdated, high maintenance, low efficiency liquid cooled system can be rebuilt with one of Tempco's turnkey Cool to the Touch heating and air cooling systems.*

**Improve Your Bottom Line**

### **Designed for Durability and Trouble-Free Operating Performance**

Tempco's **Finned Cast-In Heaters** with bolt clamping are exclusively designed to work with **Tempco's Cool to the Touch Shroud Systems**. They are manufactured with special high-efficiency fins and low overall mass cross-section for maximizing thermodynamics.



**Unmatched Quality Shroud System & Finned Cast-In Heater**

#### **Design Features**

- \* *Reduced operating costs*
- \* *Quick, easy installation*
- \* *Greater Reliability*
- \* *Thermally efficient heating & cooling characteristics*
- \* *Reduces costly downtime*
- \* *Exceptional Cast-In Heater life*
- \* *Eliminates expensive closed loop liquid cooling systems*
- \* *Rugged, Durable & Appealing Design*

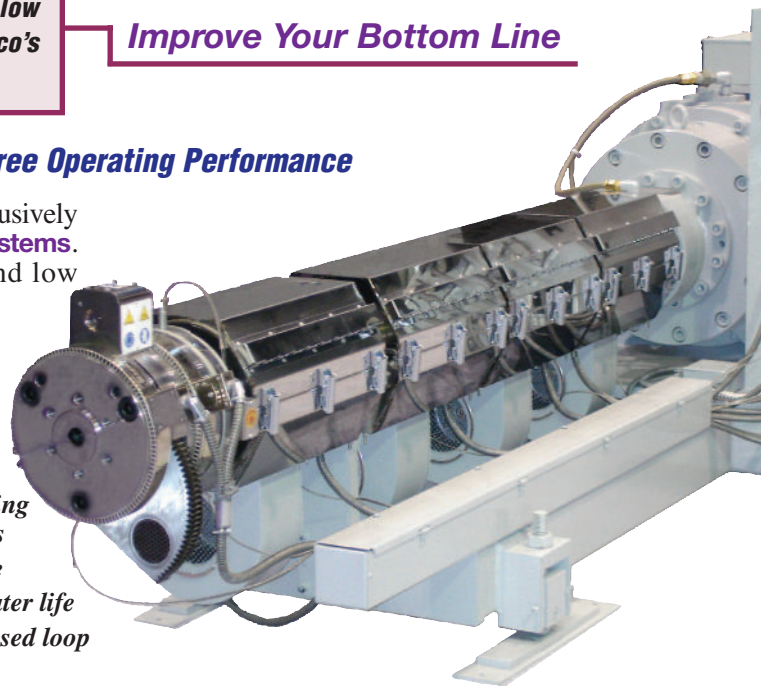

### **Liquid Cooling Cast-In Band Heaters vs. Cool to the Touch Air Cooling Shroud Systems**

#### **Liquid Cooling**

Up to now Liquid Cooling Cast-In Band Heaters have been the predominant method of controlling the melt temperature of extrusion barrels. Although effective in removing heat from the extrusion process, there are a number of drawbacks that are primarily maintenance related.

Extruders using liquid cooled Cast-In Heaters can be subject to unpredictable and untimely failures of the cooling tube assemblies, resulting in extremely costly downtime to the processor. Inherent maintenance problems include stress corrosion cracks, linear thermal expansion of the heater body, and clogging of the tubes due to accumulation of mineral deposits. Additionally, Liquid Cooled Cast-In Heaters require an expensive cooling tower or heat exchange system, extensive plumbing systems and labor for installation.

#### **A Change Is In The Air**

Tempco-designed air cooled systems have evolved considerably and become more thermally efficient as a result of geometric changes and implementation of sophisticated shrouding and air flow techniques. Optimized direction and ducting of airflow, coupled with selection of the proper blower CFM, are important to ensuring that the air cooling technique removes the proper amount of heat from the extrusion barrel. Air Cooled Cast-In Heaters are virtually maintenance free and therefore, when properly installed and applied, have the capability to far outlast and perform their liquid cooled counterparts.

**Consult Tempco With Your Requirements. We Welcome Your Inquiries.**

**(800) 323-6859 • Email: [sales@tempco.com](mailto:sales@tempco.com)**

# 3 Turnkey State-of-the-Art Systems to Improve Operating Efficiencies in Extrusion Equipment

Designed for Durability, Ease of Installation and Trouble-Free Service . . .

These highly engineered heating and cooling systems are an innovative concept in product design, offering a very efficient means to heat and cool the barrels of extruders. They provide cooling efficiencies equal to or better than conventional liquid cooled cast-in aluminum band heaters.

These shroud designs are made with stainless steel sheet metal, cast aluminum construction.

These systems are self-contained and can be supplied as turnkey ready-to-go, requiring minimum labor and installation cost, and drastically reducing downtime and maintenance upkeep compared to conventional liquid cooling and heating cast-in band heaters.

**Experience all the advantages offered by Tempco's exclusive Cool to the Touch High-Efficiency shroud and aluminum finned cast-in band heater designed system.**



The engineering of these two components is perfectly matched to work in tandem, offering thermally efficient heating and air cooling characteristics and eliminating the shortcomings of liquid cool cast-in aluminum band heaters

*Improve Efficiencies in Extrusion Processing*

### Need Assistance Selecting a System? We Welcome Your Inquiries.

If you have a special application requiring a custom manufactured system or need assistance selecting one of our standard systems for a new or existing installation, consult Tempco with your requirements. We offer complete engineering services and support, working with you every step of the way to ensure customer satisfaction.

## Selection Guide – Plastic Extruder Heating and Cooling Shroud Design Systems

	Shroud Style Construction	Recommended Heater Types	Barrel Diameter Range		Zone Length Range	
			Min.	Max.	Min.	Max.
 <b>1</b>	<b>Cool to the Touch™, Page 3-26</b> Dual Layer: Inner Stainless Steel Solid Layer; Outer Stainless Steel Perforated Layer	Tempco Finned Cast Aluminum Heaters, Vented Ceramic Band or Maxiband Heaters	3" 76 mm	23" 584 mm	5" 127mm	42" 1067 mm
 <b>2</b>	<b>Multi-Versal, Page 3-33</b> Single Stainless Steel Solid Layer	Tempco Finned Cast Aluminum Heaters, Vented Ceramic Band or Maxiband Heaters	3" 76 mm	23" 584 mm	3-3/4" 95 mm	42" 1067 mm
 <b>3</b>	<b>Arctic Cast®, Page 3-37</b> Single Cast Aluminum Solid Layer	Tempco Finned Cast Aluminum Heaters	4" 102 mm	16" 406 mm	6-1/2" 165 mm	30-1/2" 775 mm

### Cool TO-THE Touch Extruder Heat/Cool System

Tempco's Cool TO-THE Touch extruder heat/cool systems are custom engineered to provide optimal heating and cooling while providing personnel safety with a Cool Touch perforated outer layer. These systems are designed with finned cast-in heaters that optimize overall system efficiency.

The reflective inner layer of the shroud decreases the heat-up cycle, reducing energy consumption. The "maxi-flow" unrestricted blower port directs inlet air to the hottest part of the casting and distributes it evenly over the entire cross section of the zone.

## 1 – Cool to the Touch Construction

### Cool to the Touch

**Dual Layer Shroud with Inner Stainless Steel Solid Layer (thermally isolated from heater) and Outer, Cool to the Touch, Perforated Stainless Steel Layer for Maximum Venting and Heat Dissipation**

#### Usage Requirements

*The Cool TO-THE Touch Construction Style achieves best results when built for Tempco's High-Efficiency Finned Cast-In Heaters.*

### Cool to the Touch Construction Details

#### Dual Layer Shroud

- \* *Inner Stainless Steel solid layer – radiation shield that directs the cooling air flow over the heater*
- \* *Outer Stainless Steel perforated layer – isolates hot surfaces from contact (cool touch)*

#### Shroud Assembly Features

- \* *Two Mounting Styles are available:*
  - ➔ *Hinge with Barrel Clamps – designed for ease of installation*
  - ➔ *Two Individual Halves with Barrel Clamps (Two-Piece) – used where installation space is tight or mounting is difficult*
- \* *Internal Support Straps or Support U-Bolt on blower mount half of shroud permits shroud to be opened for servicing without removing unit from barrel*
- \* *Anti-Rotate Tabs – used only with Finned Cast-In Heaters to prevent shroud from radial and axial movement around the barrel*
  - ➔ *Tabs are cast as part of the heater (may require a Terminal Box)*
- \* *Blower Options – See page 3-41 through 3-43 for Complete Details*
  - ➔ *Single or Dual Tempco Recommended Blowers available from 148 CFM up to 1210 CFM at 115V or 230V, or 480V 3-Phase*
  - ➔ *Customer Specified blower*
  - ➔ *Blower not required for Heat-Only Shrouds*
- \* *Blower Location*
  - ➔ *Horizontal or Vertical Orientation*
  - ➔ *Extension Housings Available*
- \* *Standard Air Outlet combined with Terminal Box at top*
- \* *Optional Air Outlet Features Include:*
  - ➔ *Air Outlet Shield deflects air flow out of shroud and shields shroud from external solid contamination*
  - ➔ *Air Outlet separate from Terminal Box*
  - ➔ *Alternate Radial Air Outlet locations available*
- \* *Air-Inlet Baffle Optional*
- \* *Vent Hole(s) Optional*

Cool to the Touch shown with optional dual blowers mounted vertically with knockouts for heater termination(s) and top vertical air outlet



#### Heater Type and Components

- \* *Recommended Heater Types – Finned Cast-In Heaters with standard 1/4" gap between heater halves, Ceramic Band and Maxiband Heaters*
- \* *Power Input Terminal Box with 7/8" dia. K.O. for 1/2" conduit:*
  - ➔ *Standard 10-32 stud termination with ceramic or mica insulator*
  - ➔ *With Louvered Cover – used when terminal box is separate from air-outlet*
  - ➔ *Stainless Steel Screen – used when terminal box is combined with air outlet*
- \* *Power Input through Blower Mount – input wiring through knockouts in blower mount eliminates terminal box and facilitates ease of heater service*

#### Sensing and Controlling

- \* *Existing Zone Control Probe – Shroud System can be designed per customer specifications*
- \* *Tempco supplied Zone Control Probe*
- \* *Tempco customized Power Control Panel designed to complete Your Thermal Loop System*

### Ordering Information

See Page 3-36 for complete Ordering Information.

### Existing Cool TO-THE Touch Extruder Heat/Cool Systems

#### Horizontal and Vertical Blower Motor Mount Design Specifications

The following partial listings are part numbers and specifications for shroud designs that Tempco has engineered and manufactured. Each item listed below can be modified to fit customer requirements.

Zone Control Probes are placed per customer specifications. See page 3-29 for complete details.

Barrel OD (Shroud ID)	Shroud Width	Shroud OD (in)	Blower Location (in)	Air Outlet Location (°)	Terminal Box Location (°)	Blower CFM (°)	Maximum Heater OD	Heater Part Number (in)	Wattage Per Shroud	Heater Voltage	Shroud Part Number
4.25	9.25	10.06	270	90	0	273	7.75	CBH14315	3000	240	ASJ00421
4.5	10.06	9.81	180	0	45	358	7.5	CBH14322	3600	230	ASJ00423
5	9	10.56	180	0	0	273	8.25	CBH13803	4000	240	ASJ00367
5	13	10.81	180	0	0	358	8.5	CBH13011	6000	230	ASJ00281
5	13	11.56	180	0	45	458	9.25	CBH05677	4000	230	ASJ00381
5	13.63	10.81	180	0	0	358	8.5	CBH13387	6600	230	ASJ00315
5	14	10.31	180	0	45	458	8	CBH14316	6000	230	ASJ00422
5	18	10.56	180	0	0	550	8.25	(2)CBH13803	8000	240	ASJ00366
5.12	12	10.94	270	0	0	358	8.63	CBH13659	5600	400	ASJ00350
5.5	18.5	11.81	180	0	90	N/A	9	CBH13012	7000	200-3PH	ASJ00279
6	10.5	11.81	270	90	90	550	9.5	CBH12250	4000	220	ASJ00238
6.25	13.63	11.56	180	0	0	485	9.25	CBH13664	6000	230	ASJ00346
6.25	15	11.56	180	0	0	550	9.25	CBH14306	8250	240	ASJ00417
6.38	8	12.19	270	90	0	273	9.88	CBH13572	4000	240	ASJ00333
6.38	16	12.19	270	90	0	358	9.88	CBH13573	7000	240	ASJ00332
6.5	11	12.81	180	0	90	265	9.75	CBH12061	4600	240	ASJ00223
6.5	15.63	12.06	180	0	0	550	9.75	CBH13388	10000	240	ASJ00316
6.5	18	11.81	270	0	0	550	9.5	N/A	N/A	N/A	ASJ00341
6.5	18	12.81	180	0	90	550	9.75	CBH12060	7600	240	ASJ00222
6.5	21	11.81	270	0	0	550	9.5	CBH14189	8800	230	ASJ00403
6.63	17.25	12.94	270	0	0	1200	10.38	CBH13936	8800	240	ASJ00378
6.63	17.5	12.19	270	0	0	550	9.88	CBH13659	7500	230	ASJ00344
6.64	17.63	12.45	270	0	0	550	10.14	CBH13806	8720	240	ASJ00371
7	19	13.06	270	90	90	1200	10.75	CBH14114	7200	480	ASJ00396
7	21.5	14.06	180	0	N/A	550	11.25	CBH12045	4700	480	ASJ00220
7.5	12	12.81	270	0	0	485	10.5	CBH13701	6500	240	ASJ00351
7.5	17.5	13.56	180	0	90	1200	10.75	CBH12000	7500	240	ASJ00213
7.5	18.5	12.69	270	0	0	550	10.38	CBH13852	9000	230-3PH	ASJ00372
7.5	18.5	13.31	270	0	0	1200	11	CBH14099	9000	575-3PH	ASJ00394
7.5	19.5	13.82	270	0	0	797	11	CBH12232	11250	240	ASJ00228
7.5	20	12.81	180	0	0	550	10.5	CBH13010	9500	230	ASJ00280
7.5	20.5	12.81	180	0	0	1200	10.38	CBH13495	10000	240-3PH	ASJ00323
7.5	22.5	13.31	180	0	90	797	10.5	(2)CBH13219	8600	208	ASJ00293
7.5	23.5	12.81	180	0	0	1200	10.5	CBH13652	10000	240-3PH	ASJ00342
7.5	24	12.81	270	0	0	550	10.5	CBH13700	12500	240	ASJ00352
7.63	12	12.95	270	0	0	358	10.63	CBH13762	5350	230	ASJ00362
7.63	13.5	12.95	270	0	0	358	10.63	CBH13714	3480	230	ASJ00359
7.63	14.38	13.44	270	0	0	550	11.125	CBH14329	7000	230	ASJ00426

**CONTINUED**

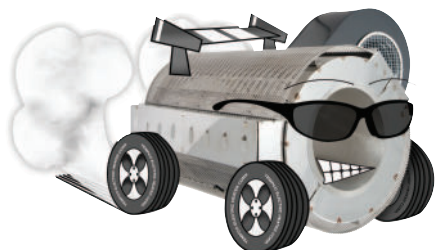

**These Energy Conserving Units  
Out-Perform All Other Plastic Extruder  
Barrel Heating & Cooling Products.**



### Existing Cool TO-THE Touch Extruder Heat/Cool Systems

#### Horizontal and Vertical Blower Motor Mount Design Specifications (continued)

The following partial listings are part numbers and specifications for shroud designs that Tempco has engineered and manufactured. Each item listed below can be modified to fit customer requirements.

Zone Control Probes are placed per customer specifications. See page 3-29 for complete details.

Barrel OD (Shroud ID)	Shroud Width	Shroud OD (in)	Blower Location (in)	Air Outlet Location (°)	Terminal Box Location (°)	Blower CFM (°)	Maximum Heater OD	Heater Part Number (in)	Wattage Per Shroud	Heater Voltage	Shroud Part Number
7.63	14.5	12.95	270	0	0	550	10.63	CBH13713	7200	230	ASJ00373
7.63	15	12.95	270	0	0	550	10.63	CBH13713	7200	230	ASJ00358
7.63	18	12.95	270	0	0	550	10.63	CBH13712	9600	230	ASJ00357
7.63	21.25	13.06	270	90	90	550	10.75	CBH13364	7500	240-3PH	ASJ00314
8	20	13.81	270	90	0	550	11.5	CBH13571	12400	240	ASJ00330
8	22.5	14.06	270	90	0	550	11.75	CBH13677	11000	480	ASJ00347
8.25	12.5	14.06	270	0	180	550	11.75	CBH14072	5500	460-3PH	ASJ00390
8.25	14.5	14.06	270	0	180	550	11.75	CBH14071	7000	460-3PH	ASJ00391
8.5	18	14.56	270	90	90	1200	12.25	CBH12944	10800	240-3PH	ASJ00285
9.25	23.375	15.06	180	0	0	1200	12.75	CBH13562	15000	480-3PH	ASJ00327
9.31	23.25	15.2	270	0	0	(2) 550	12.88	CBH12703	15000	230-3PH	ASJ00264
9.5	12.5	14.81	270	0	0	485	12.5	CBH13699	8500	240	ASJ00353
9.5	19.5	15.56	180	0	0	1200	13.25	CBH14175	16000	240	ASJ00402
9.5	24	14.81	270	0	0	1200	12.5	CBH13698	15900	240-3PH	ASJ00354
9.5	24	14.81	270	0	0	(2) 459	12.5	CBH13327	16500	240-3PH	ASJ00308
9.5	24.5	15.31	180	0	90	(2) 550	12.5	CBH11891	14600	240-3PH	ASJ00205
9.5	24.875	15.31	270	0	0	(2) 550	13	CBH14352	20000	240 -3PH	ASJ00429
9.5	27	15.56	270	90	90	(2) 1200	13.25	CBH13123	20000	240-3PH	ASJ00289
9.5	27.38	15.56	180	0	0	(2) 550	13.25	CBH13389	2400	240	ASJ00317
9.5	27.75	15.56	180	0	0	(2) 550	13.25	CBH13922	20000	480-3PH	ASJ00375
9.75	16.5	14	270	0	0	550	13.25	CBH14126	12600	240	ASJ00399
9.75	19	15.81	270	0	0	1200	13.5	CBH14300	13500	480	ASJ00415
9.75	23.375	15.56	180	0	0	1200	13.25	CBH14419	15000	480	ASJ00435
9.75	24	14	270	0	0	(2) 550	13.25	CBH14125	18370	240	ASJ00398
9.75	24	15.31	180	0	0	1200	13	(2)CBH13801	7000	240-3PH	ASJ00370
9.76	12.5	15.82	270	0	0	550	13.5	CBH13799	10000	240-3PH	ASJ00365
9.88	15.5	16.06	270	90	0	550	13.38	CBH13319	9550	240-3PH	ASJ00307
9.88	24.5	16.06	270	90	0	(2) 550	13.38	CBH13318	14600	240-3PH	ASJ00306
9.94	18	16.31	180	0	90	1200	13.44	CBH12495	16000	440	ASJ00249
9.94	23	16.31	180	0	90	1200	13.44	CBH12496	18000	440	ASJ00250
10	28	16.06	270	90	90	(2) 550	13.75	CBH14193	11000	240	ASJ00404
10.75	7.5	16.56	270	0	0	485	14.25	CBH14203	7500	480	ASJ00406
12.5	34.5	18.81	180	0	0	(2) 1200	16.5	(2)CBH13888	35000	460-3PH	ASJ00374
13.5	12	19.56	180	0	90	550	17.25	CBH13359	9000	460	ASJ00313
13.5	17.5	19.56	180	0	90	550	17.25	(2)CBH13358	14000	460	ASJ00312
13.5	23	19.56	180	0	90	(2) 550	17.25	(2)CBH13359	18000	460	ASJ00311

### Ordering Information

If you cannot find an existing shroud design that meets your requirements precisely, please use the ordering form on page 3-36 to process your quote request.

Tempco's engineering professionals will custom design a shroud system to meet your extruder process challenges.

### Existing Cool TO-THE Touch Extruder Heat/Cool System Reference Shroud Drawings

#### Vertical Blower Mounts

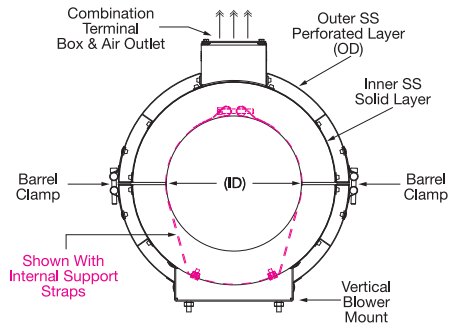

**Drawing CT1** .....

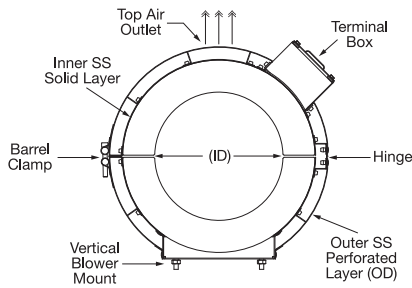

**Drawing CT2** .....

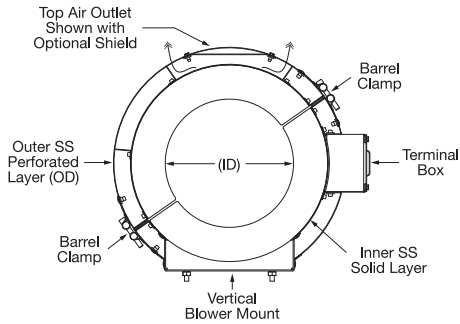

**Drawing CT3** .....

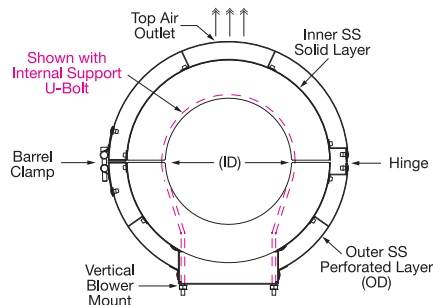

**Drawing CT4** .....

#### Horizontal Blower Mounts

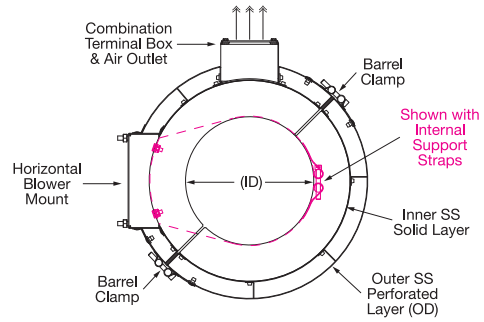

**Drawing CT5** .....

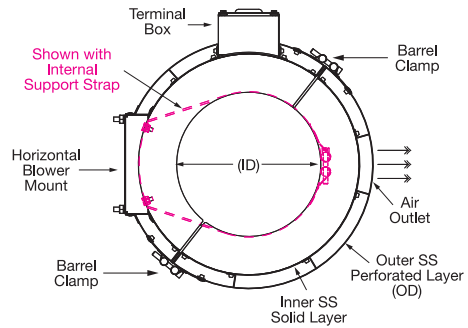

**Drawing CT6** .....

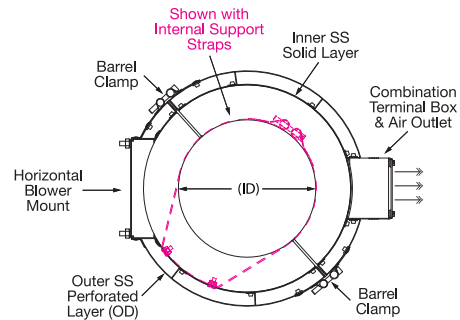

**Drawing CT7** .....

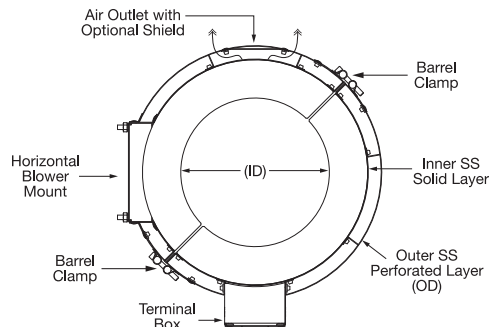

**Drawing CT8** .....

### Multi-Versal Extruder Heat/Cool System

Tempco's Multi-Versal extruder heat/cool systems are designed for efficient heating and cooling. The shroud systems can be used with many styles of band heaters. Due to the single layer design, the Multi-Versal shroud system has a low profile OD.

The reflective interior of the shroud decreases the heat-up cycle, reducing energy consumption. The unrestricted blower port directs inlet air to the hottest part of the heater and distributes it evenly over the entire cross section of the zone.

## 2 – Multi-Versal Construction

### Multi-Versal Extruder

**Solid, Stainless Steel  
Single Layer Shroud**

### Usage Requirements

*A highly adaptable single layer shroud, suited for retrofit and/or new applications regardless of the type of barrel band heater being used.*

### Multi-Versal Construction Details

#### Single Layer Shroud

- \* **Solid Stainless Steel Layer** – radiation shield that directs the cooling air flow over the heater

#### Shroud Assembly Features

- \* **Two Mounting Styles are available:**
  - ➔ **Hinge with Barrel Clamps** – designed for ease of installation
  - ➔ **Two Individual Halves with Barrel Clamps (Two-Piece)** – used where installation space is tight or mounting is difficult
- \* **Internal Support Straps or Support U-Bolt on blower mount half of shroud permits shroud to be opened for servicing without removing unit from barrel**
- \* **Anti-Rotate Tabs** – used only with **Finned Cast-In Heaters** to prevent shroud from radial and axial movement around the barrel
  - ➔ **Tabs are cast as part of the heater and may require a Terminal Box**
- \* **Blower Options** – See page 3-41 through 3-43 for Complete Details
  - ➔ **Single or Dual Tempco Recommended Blowers available from 148 CFM up to 1210 CFM at 115V or 230V, or 480V 3-Phase**
  - ➔ **Customer Specified blower**
  - ➔ **Blower not required for Heat-Only Shrouds**
- \* **Blower Location**
  - ➔ **Horizontal or Vertical Orientation**
  - ➔ **Extension Housings Available**
- \* **Standard Air Outlet combined with Terminal Box at top**
- \* **Optional Air Outlet Features Include:**
  - ➔ **Air Outlet separate from Terminal Box**
  - ➔ **Alternate Radial Air Outlet locations available**
- \* **Shroud Air-Inlet Baffle Optional**
- \* **Vent Hole(s) Optional**



Multi-Versal shown with horizontally mounted blower & vertical combination terminal box & air outlet

#### Heater Type and Components

- \* **Recommended Heater Types** – **Finned Cast-In Heaters** with standard 1/4" gap between heater halves, **Ceramic Band** and **Maxiband Heaters**
- \* **Power Input Terminal Box** with 7/8" dia. K.O. for 1/2" conduit:
  - ➔ **Standard 10-32 stud termination with ceramic or mica insulator**
  - ➔ **With Louvered Cover** – used when terminal box is separate from air-outlet
  - ➔ **Stainless Steel Screen** – used when terminal box is combined with air outlet
- \* **Power Input through Blower Mount** – input wiring through knockouts in blower mount eliminates terminal box and facilitates ease of heater service

#### Sensing and Controlling

- \* **Existing Zone Control Probe** – Shroud System can be designed per customer specifications
- \* **Tempco supplied Zone Control Probe**
- \* **Tempco customized Power Control Panel** designed to complete Your Thermal Loop System

### Ordering Information

See Page 3-36 for complete Ordering Information.

**(800) 323-6859 • Email: sales@tempco.com**



### Multi-Versal Extruder Heat/Cool System

#### Horizontal and Vertical Blower Motor Mount Design Specifications

The following partial listings are part numbers and specifications for shroud designs that Tempco has engineered and manufactured. Each item listed below can be modified to fit customer requirements. Zone Control Probes are placed per customer specifications. See page 3-33 for complete details.

Barrel OD (Shroud ID)	Shroud Width	Shroud OD (in)	Blower Location (in)	Air Outlet Location (°)	Terminal Box Location (°)	Blower CFM (°)	Maximum Heater OD	Heater Part Number (in)	Wattage Per Shroud	Heater Voltage	Shroud Part Number
5.5	13	9.5	180	0	0	273	8.75	CBH07945	5600	600	ASJ00041
5.9	16	10.97	270	0	0	550	9.875	CBH14346	8000	240-3PH	ASJ00427
6.25	13.5	10.82	180	0	0	550	10	BCH06668	6000	240	ASJ00292
6.25	14	10.5	180	0	0	550	9.75	CBH14356	6800	240	ASJ00431
6.25	18.5	10.25	180	0	0	550	9.5	CBH11500	8800	460	ASJ00177
6.5	13	10.32	180	0	0	358	9.5	CBH13473	7500	240	ASJ00321
6.5	15.5	10.75	180	0	0	358	10	CBH11428	8000	575	ASJ00167
6.625	18.5	10.625	180	0	0	550	9.875	CBH07947	8800	460	ASJ00042
6.63	17.5	11.2	270	0	0	485	10.38	CBH14069	9250	480	ASJ00389
7.5	14.25	11.25	180	0	0	550	10.5	CBH13306	7000	240	ASJ00304
7.5	18	11.25	180	0	0	550	10.5	CBH13305	10600	240	ASJ00303
7.5	20.5	11.75	90	270	270	797	11	(2)BCH07244	6000	480	ASJ00380
7.5	29	11.25	180	0	0	(2) 550	10.5	(2)CBH13307	16200	240	ASJ00302
8.5	10.25	12.5	270	0	0	485	11.75	BCH07114	2200	240	ASJ00363
8.5	15.25	13	90	0	NONE	1200	12.25	CBH13467	6000	230	ASJ00320
9.5	27.5	14	180	0	0	(2) 732	13.25	(2)CBH13149	12000	230	ASJ00290
9.5	27.75	14	180	0	0	(2) 550	13.25	CBH14088	24000	480-3PH	ASJ00393
9.75	11.5	13.75	180	0	0	358	13	CBH09965	9000	230	ASJ00078
9.75	11.5	13.75	180	0	NONE	358	13	CBH09965	9000	230	ASJ00131
9.75	19.5	15	180	0	NONE	1200	14.25	CBH12313	12600	240	ASJ00076
9.75	23.5	13.5	180	0	0	(2) 485	12.75	CBH10719	16000	240	ASJ00112
9.88	22	14.13	180	0	NONE	1200	13.38	CBH13711	10500	220	ASJ00355
10.75	11	15	180	0	0	550	14.25	CBH14235	8800	230	ASJ00408
11.5	15.38	16	180	0	0	797	15.25	CBH13295	11000	460	ASJ00301
12.25	17.75	16.75	180	0	0	1200	16	CBH13347	16500	230-3PH	ASJ00310

### Ordering Information

If you cannot find an existing shroud design that meets your requirements precisely, please use the ordering form on page 3-36 to process your quote request.

Tempco's engineering professionals will custom design a shroud system to meet your extruder process challenges.

### Existing Multi-Versal Extruder Heat/Cool System Reference Shroud Drawings

#### Vertical Blower Mounts

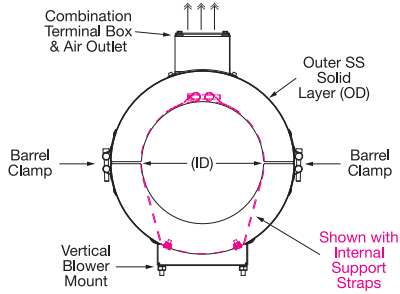

**Drawing MV1** .....

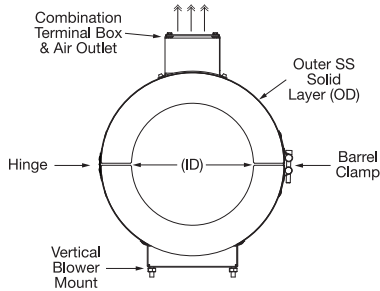

**Drawing MV2** .....

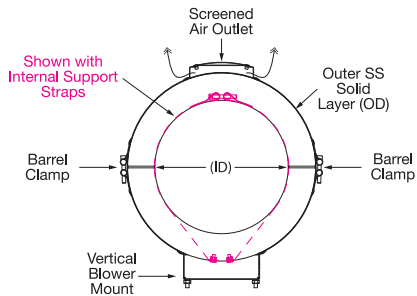

**Drawing MV3** .....

#### Horizontal Blower Mounts

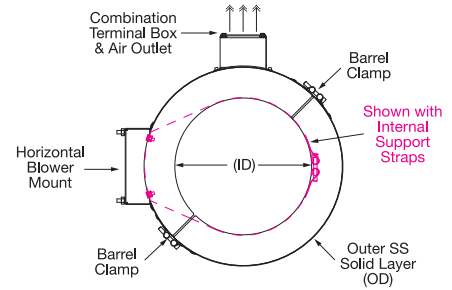

**Drawing MV4** .....

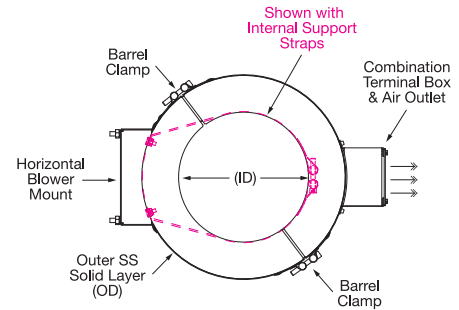

**Drawing MV5** .....

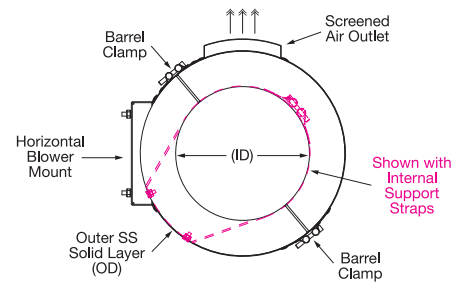

**Drawing MV6** .....

# Cast-In Heaters



## Stainless Steel Shroud Systems

### Made-To-Order Quote Request Form — Copy and Fax Us (630-350-0232) Your Requirements

#### Customer Information

Name: \_\_\_\_\_ Company: \_\_\_\_\_ City: \_\_\_\_\_ State: \_\_\_\_\_  
 Phone: \_\_\_\_\_ Fax: \_\_\_\_\_ Email: \_\_\_\_\_  
 Extruder Barrel Manufacturer: \_\_\_\_\_ Model Number: \_\_\_\_\_  
 Resin Type: \_\_\_\_\_ Process Temperature: \_\_\_\_\_

**When submitting this form, please be sure to include an extruder barrel sketch or drawing that includes the following:**

- \* Extruder Barrel Support(s)      \* Number of Heating Zones      \* Vent Location(s)      \* Zone Probe Location(s)
- \* Input Feed Location      \* Pressure Tap Location(s)      \* Zone Length(s)      \* Additional Restriction(s)

**Note:** To assist Tempco in designing a shroud system, please provide digital images (in .jpg format) of the extruder barrel.

#### Shroud Specifications

(For replacement of existing Tempco Shroud(s), please contact your Tempco Factory or Sales Representative.)

**Shroud Style:**  Cool TO-THE Touch™  Multi-Versal      Quantity Required: \_\_\_\_\_

#### Shroud Dimensions

Shroud Width / Zone Length: \_\_\_\_\_ Extruder Barrel OD / Shroud ID: \_\_\_\_\_  
 Maximum Shroud OD: \_\_\_\_\_ (determined by Engineering unless specified by customer)  
 Existing Heater OD (including terminations): \_\_\_\_\_ (determined by Engineering when new Tempco Heater is purchased)  
**Internal Shroud Support Required:**  Yes  No

#### Shroud Components and Component Locations

**Component Options** (see pages 3-29 or 3-33 for shroud component details)

1. Blower Mount:
  - Horizontal       Vertical
2. Air Outlet:
  - Separate from Terminal Box       Combined w/ Terminal Box
3. Terminal Box:
  - None       Louvered (Separated from Air Outlet)
  - Screened (Combined with Air Outlet)
4. Clamping Method at Shroud Opening:
  - Barrel Clamps with Hinge       Barrel Clamps (no Hinge)
  - Adjustable Clamps with Hinge       Adjustable Clamps (no Hinge)
5. Zone T/C Probe(s) - Customer Specified:
 

Quantity: \_\_\_\_\_ Clearance Hole Diameter(s): \_\_\_\_\_

#### Please indicate Component Radial Locations:

- 1 \_\_\_\_\_  
Blower Mount
- 2 \_\_\_\_\_  
Air outlet
- 3 \_\_\_\_\_  
Terminal Box
- 4 \_\_\_\_\_  
Clamps
- \_\_\_\_\_ Hinge (if applicable)
- 5 \_\_\_\_\_  
Zone T/C Probe(s)

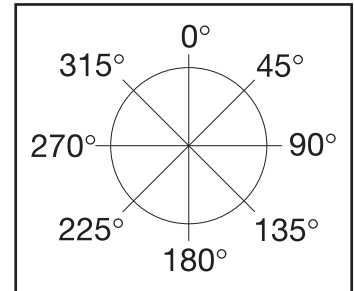

#### Blower Specifications

 (see page 3-43 for standard Tempco blowers & configuration details)

**Configuration:**  Single  Dual  Customer Supplied (\*see below)  
 Stock Tempco Blower (Engineering will determine specifications if none specified)  
 P/N: \_\_\_\_\_ or CFM: \_\_\_\_\_ Volts: \_\_\_\_\_ Operating Frequency: \_\_\_\_\_ Hz  
 Optional Blower Extension:  Horizontal  Vertical  Custom (Consult Tempco.)  
 \*Customer Supplied Blower (Please attach mounting information when submitting this form.)  
 Manufacturer: \_\_\_\_\_ P/N: \_\_\_\_\_ CFM: \_\_\_\_\_ Volts: \_\_\_\_\_ Operating Frequency: \_\_\_\_\_ Hz

#### Heater Specifications

**Existing Tempco Heater:** P/N: \_\_\_\_\_  Replace Existing Heater  Cover Existing Heater

**If purchasing new Tempco Heater(s), please provide the following information if known:**

Type and Quantity Required:  
 Qty. Cast-In(s) \_\_\_\_\_ Qty. Ceramic Bands \_\_\_\_\_ Qty. Maxibands \_\_\_\_\_  
 Inner Diameter: \_\_\_\_\_ Width(s): \_\_\_\_\_ Wattage per Shroud: \_\_\_\_\_ Voltage: \_\_\_\_\_

**⚠ WARNING: Cancer and Reproductive Harm - [www.P65Warnings.ca.gov](http://www.P65Warnings.ca.gov).**

### Arctic Cast® Extruder Heat/Cool System

Tempco's Arctic Cast Shroud System was our pioneer shroud design for the air-cooling of extruders. The cooling efficiency of the Arctic Cast shroud system meets or exceeds that of water-cooled systems when used with our field proven high-capacity blowers.

The Arctic Cast shroud features a vented 1/4" thick cast aluminum layer for durability. The cast-in heaters are designed with a large fin surface area to maximize cooling efficiency. The blower port directs inlet air to the hottest part of the heater, distributing it evenly over the entire cross section of the zone.

## 3 – Arctic Cast Construction

### Arctic Cast Extruder

**Single Layer Shroud – Vented Cast Aluminum layer bolted directly onto Tempco's Specially Designed Finned Cast-In Aluminum Band Heater**

#### Usage Requirements

*This rugged shroud design is recommended for installations where the shroud system could be exposed to physical damage, such as instances where the extruder barrel is low to the ground. It is suited to work with Tempco's Specially Designed Finned Cast-In Aluminum Heater and cannot be used on any existing finned cast-in heaters.*

### Arctic Cast Construction Details

#### Single Layer Shroud

- \* *Vented 1/4" thick Cast Aluminum layer – directs the cooling air flow over the heater*

#### Shroud Assembly Features

- \* *Two Individual Halves bolted together (Two-Piece) and clamped around finned cast heater*
- \* *Blower Options – See Pages 3-41 through 3-43 for complete details*
  - *Single or Dual Tempco Recommended Blowers available from 148 CFM up to 1210 CFM at 115V or 230V, or 480V 3-Phase*
  - *Customer Specified blower*
- \* *Blower Location*
  - *Vertical Orientation – at the bottom of the shroud*
  - *Custom location achieved only by rotating entire shroud system*
- \* *Standard top Air Outlet*
  - *Custom location achieved only by rotating entire shroud system*
- \* *Shroud Air-Inlet Baffle with built-in air deflector that breaks up incoming airflow, distributing it across the cast-in heater(s)*



Arctic Cast shown with Vertical Mount Option

#### Heater Type and Components

- \* *Recommended Heater Types – Tempco Finned Cast-In Heaters with standard 1/4" gap between heater halves and bolt and nut clamping*
- \* *Heater Strap Clamping is available*
- \* *Power Input with Standard 10-32 stud termination with ceramic or mica insulator*
  - *Bus Wiring between halves is optional*

#### Sensing and Controlling

- \* *Existing Zone Control Probe – Shroud System can be designed per customer specifications*
- \* *Tempco supplied Zone Control Probe*
- \* *Tempco customized Power Control Panel designed to complete Your Thermal Loop System*

### Ordering Information

See Page 3-40 for complete Ordering Information.

### Standard (Non-Stock) Arctic-Cast® Cast-In Heaters (319 Aluminum) and Shrouds

Heater I.D. in	Heater O.D. in	Heater Length in	Watts Each Half	Volts Each Half	Phase	Termination Type	Clamping Type	Cast-In Heater Part Number	Shroud Dimensions				Shroud Style	Shroud Part Number
									I.D. in	Length "L" in	"G" in	"H" in		
3	7	5.5	650	240	1	R	Bolt	CBH13085	7	4.375	3.7	3.22	A	ASF01218
3	7	7	1000	240	1	E	Bolt	CBH13537	7	7	1.5	4.125	A	ASF01221
3.75	7.75	13	2300	240	1	E	Bolt	CBH09406	7.75	13	6	5	A	ASF01160
4.25	7.5	13	2910	230	3	E	Strap	CBH08563	7.5	13	3.5	2.5	B	ASF01138
4.5	9	10.75	1620	230	1	E	Strap	CBH02937	9	10.75	5	6	A	ASF01006
4.5	7.75	12.25	1500	230	1	E	Strap	CBH05676	7.75	12.25	4.406	4.375	C	ASF01052
4.5	8.25	12.5	2500	240	1	C4	Bolt	CBH14435	8.25	12.5	6	5	A	ASF01232
5	9	12.438	2000	230	1	E	Strap	CBH05677	9	12.438	4.406	4.375	C	ASF01053
5.25	8.5	13.5	3750	190	3	E	Strap	CBH08561	8.5	13.5	3.5	2.5	B	ASF01136
5.5	10	11	2100	230	1	E	Strap	CBH02803	10	11	5	6	A	ASF01002
5.5	10	15.5	4000	240	1	E	Bolt	CBH10185	10	15.5	6.25	7.25	A	ASF01183
5.5	9.5	18	1200	277	1	E	Strap	CBH10258	9.5	18	8.813	2.188	A	ASF01186
6	10	11	3300	230	1	S	Strap	CBH04243	10	11	5	6	A	ASF01002
6	10	18	5000	240	1	E	Bolt	CBH09383	10	18	6.25	7.25	A	ASF01158
6	10	16	4000	240	1	E	Bolt	CBH11316	10	16	6.25	7.25	A	ASF01199
6	10	10	3750	240	3	T	Bolt	CBH12072	10	10	4.875	4.375	A	ASF01211
6	9.75	18	5000	240	1	S	Bolt	CBH14604	9.75	18	7.75	4	A	ASF01236
6.25	10.5	15	4800	230	1	E	Strap	CBH07349	10.5	15	4.875	4.375	A	ASF01095
6.5	11	17.5	3600	230	1	E	Strap	CBH02802	11	17.5	5	6	A	ASF01003
6.5	10	10.75	2280	240	1	E	Strap	CBH06509	10	10.75	4.875	2.375	A	ASF01076
6.5	11	17.5	3600	230	1	E	Strap	CBH07372	11	17.5	4.625	5.625	A	ASF01098
6.5	10.5	13	4000	240	1	E	Strap	CBH09413	10.5	13	4.875	4.375	A	ASF01161
6.5	10.5	16	4000	240	3	E	Strap	CBH09414	10.5	16	4.875	4.375	A	ASF01162
6.635	11	17.5	4360	240	1	S	Bolt	CBH06070	11	17.5	4.86	4.37	A	ASF01008
7	11	13.5	2400	230	1	E	Strap	CBH05871	11	13.5	4.406	4.375	C	ASF01057
7	10.25	18	6000	230	3	E	Strap	CBH08425	10.25	18	4.438	4.375	C	ASF01134
7	11	17.5	6000	240	1	S	Strap	CBH08635	11	17.5	4.375	4.875	A	ASF01143
7	11	19	6000	240	3	E	Bolt	CBH09362	11	19	6.5	7.25	A	ASF01157
7.5	12	18	3500	230	1	E	Strap	CBH05574	12	18	5	5	A	ASF01048
7.5	12	17	3000	480	1	E	Strap	CBH06561	12	17	3.5	3.5	A	ASF01035
7.5	11.5	18	6000	240	3	E	Strap	CBH08685	11.5	18	4.875	2.375	A	ASF01066
7.5	10.75	19	7500	190	3	C4	Bolt	CBH14386	10.75	19	8.75	4	A	ASF01227
7.5	10.75	19	7500	240	3	C4	Bolt	CBH15013	10.75	19	8.75	4	A	ASF01227
8	12	14	3250	230	1	E	Strap	CBH03738	12	14	5	5	A	ASF01013
8	12	18	5000	480	3	C4	Bolt	CBH06432	12	18	3.875	3.875	A	ASF01069
8	11.25	16	2750	230	1	E	Bolt	CBH13777	11.25	16	8.813	4.375	A	ASF01224
8.25	12.25	13	3850	230	1	S	Strap	CBH03994	12.25	13	5	4.875	A	ASF01019
8.5	11.75	10	4425	230	3	E	Strap	CBH08562	11.75	10	4.406	4.375	C	ASF01137
8.5	12	17	5900	240	1	E	Strap	CBH10213	12	17	6	5	A	ASF01185
9	13	18.75	5000	230	1	E	Strap	CBH08278	13	18.75	4.375	5.5	C	ASF01126
9.5	13.25	13	3000	240	0	E	Bolt	CBH13600	13.25	13	4.96	5.94	A	ASF01222
9.75	13.75	19	7500	480	3	S	Bolt	CBH05684	13.75	19	3.875	3.875	A	ASF01054
9.75	13.75	22	6000	230	1	E	Bolt	CBH08024	13.75	22	6.452	6.452	A	ASF01119
9.75	13.75	19	6000	230	1	E	Bolt	CBH08025	13.75	19	5	6	B	ASF01120
9.75	13.75	22	11000	200	3	F	Bolt	CBH10086	13.75	22	6.452	6.452	A	ASF01181
10	9	12	6480	230	3	S	Strap	CBH05102	9	12	5	6	A	ASF01006
10	13.5	24	11000	600	3	R1A	Bolt	CBH07294	13.5	24	6.25	6.25	A	ASF01094
10	14	12	6480	230	1	E	Strap	CBH07404	14	25	6	5	B	ASF01101
10	13.25	12	6480	230	3	E	Strap	CBH08424	13.25	12	4.406	4.375	C	ASF01129
10	14	12	6480	480	1	E	Strap	CBH14775	14	12	6	5	B	ASF01101
12	16	14.5	4250	240	3	E	Strap	CBH09876	16	14.5	5.504	5.504	A	ASF01172
12	16	23	6500	480	1	E	Bolt	CBH11446	16	23	6.5	4	C	ASF01203
13	16.25	13.75	6750	190	3	E	Strap	CBH09878	16.25	13.75	4.406	4.375	C	ASF01173

The typical Arctic Cast System consists of:

- A Cast-In Aluminum Finned Band Heater
- A Cast Aluminum Shroud
- An appropriately rated Forced Air Blower



**Note:** For additional information on sizing and selecting Cast-In Band Heaters for your application, see page 3-39. To order an Arctic-

Page 3-37 illustrates the complete system as well as the components that make up each assembly. Envelope dimensions for the shrouds shown on page 3-39 are also provided. Pages 3-41 through 3-43 display different forced air blower styles and specifications.

Cast system not shown in our Standard Sizes and Ratings, consult Tempco or send us your specifications and/or drawing.

### Selection of Arctic Cast® Shroud Design Styles

#### Shroud Style A

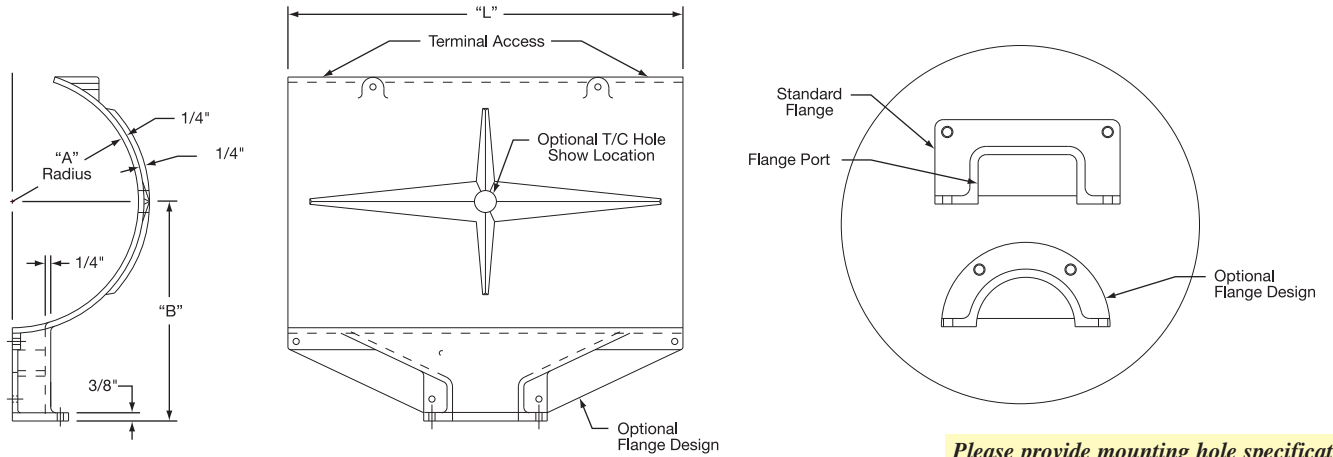

*Please provide mounting hole specifications if using other than Tempco standard.*

#### Shroud Style B

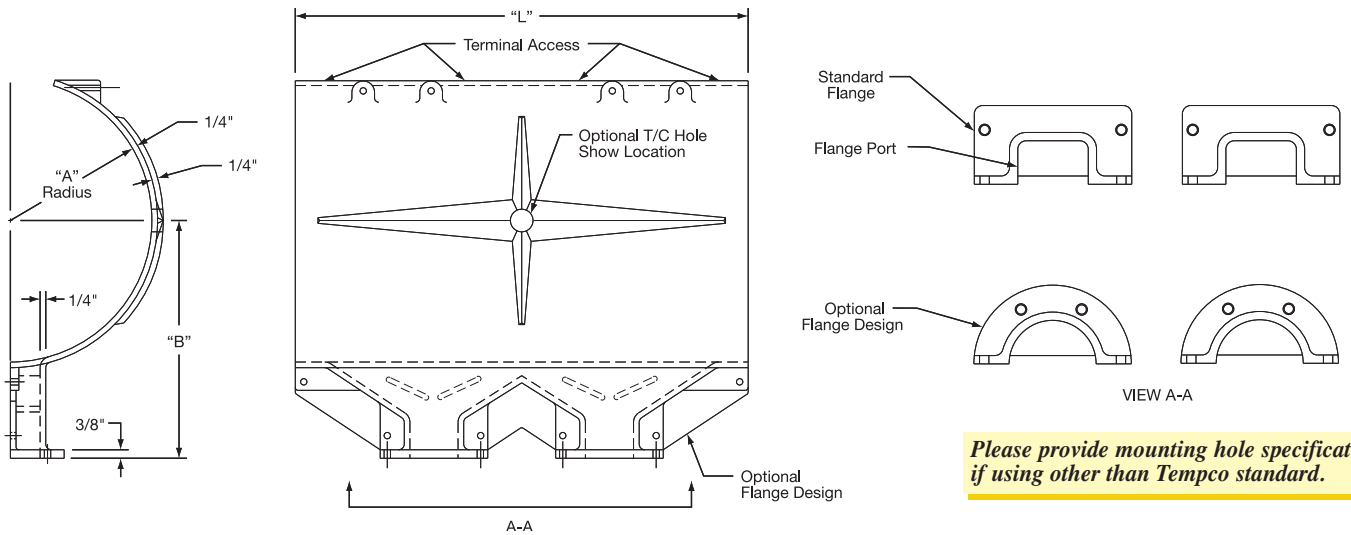

*Please provide mounting hole specifications if using other than Tempco standard.*

#### Shroud Style C

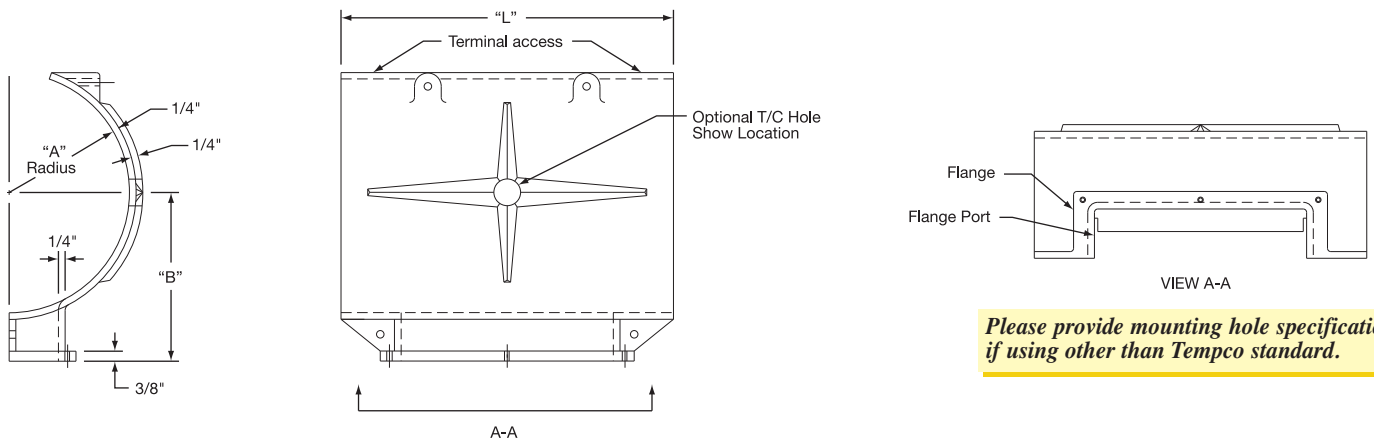

*Please provide mounting hole specifications if using other than Tempco standard.*

# Cast-In Heaters



## Arctic Cast® Shroud System

**Made-To-Order Quote Request Form — Copy and Fax Us (630-350-0232) Your Requirements**

### Customer Information

Name: \_\_\_\_\_ Company: \_\_\_\_\_ City: \_\_\_\_\_ State: \_\_\_\_\_  
 Phone: \_\_\_\_\_ Fax: \_\_\_\_\_ Email: \_\_\_\_\_  
 Extruder Barrel Manufacturer: \_\_\_\_\_ Model Number: \_\_\_\_\_  
 Resin Type: \_\_\_\_\_ Process Temperature: \_\_\_\_\_

**When submitting this form, please be sure to include an extruder barrel sketch or drawing that includes the following:**

- \* Extruder Barrel Support(s)
- \* Number of Heating Zones
- \* Vent Location(s)
- \* Zone Probe Location(s)
- \* Input Feed Location
- \* Pressure Tap Location(s)
- \* Zone Length(s)
- \* Additional Restriction(s)

**Note:** To assist Tempco in designing a shroud system, please provide digital images (in .jpg format) of the extruder barrel.

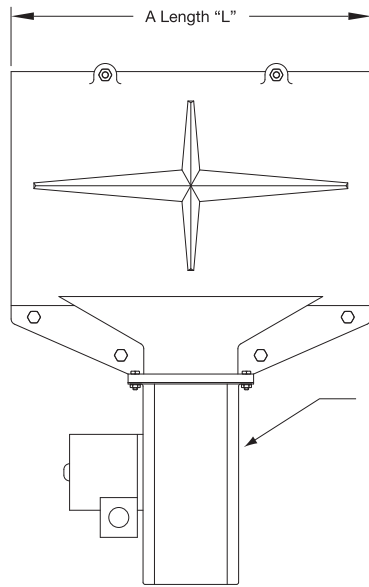
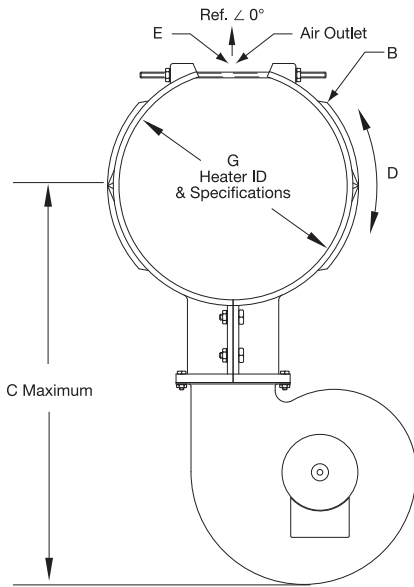

**Drawing Reference Angle**

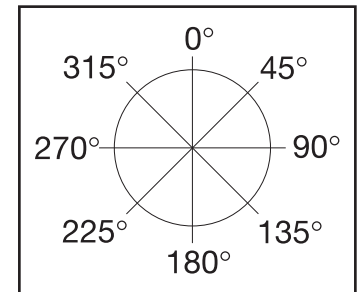

### Shroud Specifications

(For replacement of existing Tempco Shroud(s), please contact your Tempco Factory or Sales Representative.)

- A. Shroud Width / Zone Length "L": \_\_\_\_\_  
 B. Maximum Shroud OD: \_\_\_\_\_ (determined by Engineering unless specified by customer)

### Shroud Component Specifications

- C. Maximum Blower Clearance: \_\_\_\_\_  
 D. Standard Shroud Assembly Orientation Shown: Air Outlet at 0°, Blower at 180°  
 For alternate orientations, rotate shroud and heater assembly on extruder barrel.  
 E. Zone T/C Probe(s): Quantity: \_\_\_\_\_ Clearance Hole Diameter: \_\_\_\_\_  
 Location:  Centered at Top (standard)  Custom: \_\_\_\_\_ (Indicate Clockwise from Drawing Reference Angle)

### Blower Specifications

- F. **Configuration:**  Single  Dual  Customer Supplied (\*see below)  
 Stock Tempco Blower (Engineering will determine specifications if none specified)  
 P/N: \_\_\_\_\_ or CFM: \_\_\_\_\_ Volts: \_\_\_\_\_ Operating Frequency: \_\_\_\_\_ Hz  
 Optional Inlet Guard (available for most stock blowers)  
 Optional Blower Extension:  Horizontal  Vertical  Custom (Consult Tempco.)  
 Mounting Dimensions: Length \_\_\_\_\_ Width \_\_\_\_\_  
 \*Customer Supplied Blower (Please attach mounting information when submitting this form.)  
 Manufacturer: \_\_\_\_\_ P/N: \_\_\_\_\_ CFM: \_\_\_\_\_ Volts: \_\_\_\_\_ Operating Frequency: \_\_\_\_\_ Hz

### Heater Specifications

- G. Extruder Barrel OD/Heater ID: \_\_\_\_\_ Wattage per Half: \_\_\_\_\_ Voltage per Half: \_\_\_\_\_

**⚠ WARNING: Cancer and Reproductive Harm - [www.P65Warnings.ca.gov](http://www.P65Warnings.ca.gov).**

### Forced-Air Blowers for Air-Cooled Heating Systems

A variety of sizes and styles of forced-air centrifugal blowers are used on Tempco's air-cooled extrusion systems. Tempco Forced-Air Blowers are available in a large range of CFM ratings to fit any new or existing application. All blowers include air inlet guards for your safety.



#### Standard Single Phase Centrifugal Blowers

Tempco standard blowers feature corrosion protected sheet metal housings and impeller wheels. The quiet operation and quick response coupled with high volume unrestricted output results in a field-proven efficient cooling means for extrusion processes. Standard blowers are readily available for single phase 115V or 230V and represent the shortest delivery times.

#### Single Port Blowers

Part Number	"D"	"F"	"G"	"H"	"N"	"P"	"R"	"S"	Outlet "L" x "W"	CFM	Volts	Full Load Amps	Replacement Guard PN
MTR-102-101	3.50	4.60	3.96	2.88	6.91	6.26	5.32	5.70	2.18 x 3.25	146	115	0.75	GRD-101-102
MTR-102-102	5.00	5.51	4.86	4.37	8.21	7.56	8.88	9.90	3.62 x 4.13	273	115	0.77	GRD-101-117
MTR-102-103	5.00	5.51	4.86	4.37	8.21	7.56	8.88	9.90	3.62 x 4.13	273	230	0.43	GRD-101-117
MTR-102-104	5.63	5.08	4.50	5.00	8.09	7.48	10.44	11.16	4.25 x 3.81	358	230	0.54	GRD-101-104
MTR-102-105	5.63	5.08	4.50	5.00	8.09	7.48	10.40	11.20	4.25 x 3.81	485	115	1.35	GRD-101-104
MTR-102-106	5.63	6.63	6.00	5.00	9.59	8.92	10.42	11.16	4.25 x 5.25	550	115	2.05	GRD-101-104
MTR-102-107	5.63	6.63	6.00	5.00	9.59	8.92	10.40	11.20	4.25 x 5.25	550	230	0.98	GRD-101-104
MTR-102-108	6.37	8.75	8.00	5.00	11.56	11.56	13.13	14.88	5.56 x 7.19	1202	115/230	7.30/3.70	GRD-101-108
MTR-102-113	6.37	7.75	7.00	5.00	10.31	10.31	13.13	14.88	5.56 x 6.19	794	115/230	2.75/1.45	GRD-101-108

**NOTE:** See Blower Drawing 1 on page 3-43

#### Single Port Large Volume Blowers

Part Number	"D"	"F"	"G"	"H"	"N"	"R"	"S"	Outlet "L" x "W"	CFM	Volts	Full Load Amps	Replacement Guard PN
MTR-102-109	5.00	9.69	4.41	4.38	9.25	8.81	9.88	3.69 x 8.06	458	115	1.28	GRD-101-117
MTR-102-110	5.00	9.69	4.41	4.38	9.45	8.81	9.88	3.69 x 8.06	458	230	0.65	GRD-101-117
MTR-102-111	5.63	9.31	4.38	5.00	10.75	10.31	11.13	4.19 x 8.69	797/549	115	3.20/2.20	GRD-101-104

**NOTE:** See Blower Drawing 2 on page 3-43

#### Double Port Blowers

Part Number	"D"	"F"	"G"	"H"	"M"	"N"	"P"	"R"	"S"	Outlet "L" x "W"	CFM	Volts	Full Load Amps	Replacement Guard PN
MTR-102-112	4.75	4.75	4.13	1.47	7.50	12.20	10.90	8.06	7.89	2.94 x 3.31	312	115	0.77	GRD-101-117

**NOTE:** See Blower Drawing 3 on page 3-43



#### Low-Profile Single Phase Centrifugal Blowers

Tempco low-profile 115/230V single phase blowers offer a narrower footprint than the standard blowers. The motor is integrated with the impeller so that the motor housing protrudes only slightly from the blower housing. Low-profile blowers are made of die-cast aluminum and galvanized sheet steel and are perfect for applications where space is a concern.

#### Single Port Blowers

Part Replacement Number	"D"	"F"	"G"	"H"	"N"	"P"	"R"	"S"	Outlet "L" x "W"	CFM	Volts	Full Load Amps	Replacement Guard PN	Capacitor PN
MTR-103-101	2.68	3.00	2.60	2.28	3.44	3.15	4.65	4.50	2.19 x 1.66	56	115	0.24	GRD-101-101	TEC-114-101
MTR-103-102	2.68	3.00	2.60	2.28	3.44	3.15	4.65	4.50	2.19 x 1.66	56	230	0.13	GRD-101-101	TEC-114-102
MTR-103-103	4.72	5.12	4.53	4.13	5.12	3.94	8.90	9.72	3.62 x 3.70	283	230	0.89	GRD-101-103	TEC-114-101
MTR-103-104	7.40	6.96	5.00	6.00	5.27	4.96	11.28	14.04	4.79 x 5.27	500	230	0.78	GRD-101-106	TEC-114-101

**NOTE:** See Blower Drawing 1 on page 3-45

### Forced-Air Blowers for Air-Cooled Heating Systems

#### Universal Three-Phase Centrifugal Blowers



Tempco high-end blowers use heavy duty construction for a long service life. They are available with universal three-phase motors for 50/60 HZ operation on voltages from 202 up to 530V. They meet Cenelec standards and are IP41 or IP54 rated with class B or F insulation systems. These low noise, continuous duty rated blowers operate efficiently under higher static pressure loads than our standard blowers. Optional attachments are available for transferring high temperature air up to 200-300° C and inlet filters for dusty environments.

#### Single Port Blowers — 3-Phase 60 Hz (202-306V 3-Ph. Delta, 350-530V 3-Ph. Y)

Part Number	"D"	"F"	"G"	"H"	"N"	"P"	"R"	"S"	Outlet "L" x "W"	CFM	Volts	Full Load Amps
MTR-104-101	3.85	4.41	3.74	3.15	9.17	8.62	7.75	3.00	2.56 x 3.11	253-300	240/480	0.51/0.29
MTR-104-102	5.11	5.51	4.72	4.33	11.85	11.06	8.81	8.97	3.54 x 3.66	459-556	240/480	1.15/0.65
MTR-104-103	5.51	5.91	5.19	4.72	13.62	13.00	9.49	10.43	3.90 x 4.29	732-853	240/480	2.30/1.35
MTR-104-104	6.14	6.61	5.94	4.96	15.02	14.25	10.51	11.73	4.41 x 4.88	1130-1200	240/480	4.00/2.30

**NOTE:** See Blower Drawing 1 on page 3-43

#### Double Port Blowers — 3-Phase 60 Hz (202-306V 3-Ph. Delta, 350-530V 3-Ph. Y)

Part Number	"D"	"F"	"G"	"H"	"M"	"N"	"P"	"R"	"S"	Outlet "L" x "W"	CFM	Volts	Full Load Amps
MTR-104-105	5.19	5.51	4.72	4.33	9.74	15.25	13.68	8.82	8.98	3.54 x 3.66	550-665	240/480	1.10/0.65

**NOTE:** See Blower Drawing 3 on page 3-43

#### Extensions for Forced-Air Blowers

Blower extensions are available for applications where space restrictions do not allow the blower to be mounted directly to the shroud assembly.



**Horizontal Blower Extension** allows blower to be mounted perpendicular to the shroud. A baffle inside the blower extension smoothly guides air flow into the shroud.

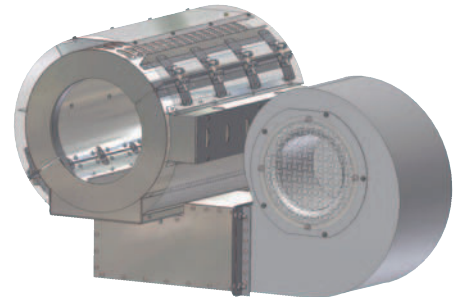

**Vertical Blower Extension** allows blower to be vertically offset at a distance below the shroud as specified by the customer. Especially useful in retrofit applications.



**Vertical Blower Extension with 90° adapter plate** allows blower to be vertically offset from the shroud. Blower can be rotated at 90° intervals relative to the extension.



### Inlet Guards for Single Inlet Centrifugal Blowers

Single Port Blower: Drawing 1

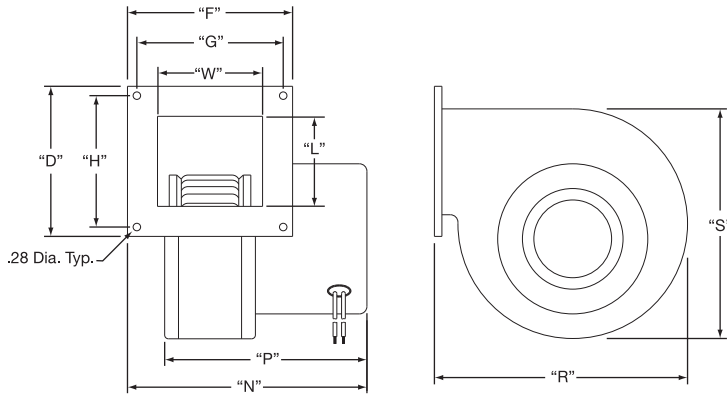

**Special cast housing narrow blowers** for small extruders or short barrel zone widths are available from 23 up to 350 CFM.

**Single port blowers** can be obtained up to 1210 CFM for use in large extruder installations. Consult Tempco with your requirements.

Single Port Large Volume Blower: Drawing 2

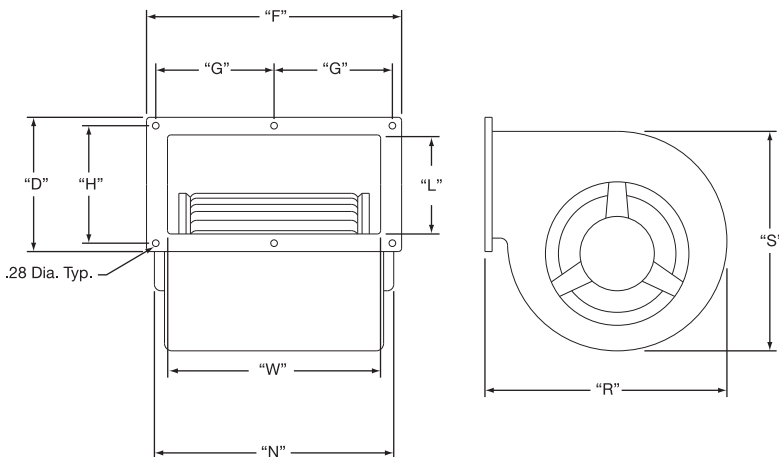

**Note:** Blower's wheel and motor assembly is mounted within the sheet metal housing, allowing air in from both ends.

Additional sizes of two-speed blowers rated 435/296 are also available. A full range of special dual inlet sizes from 120 CFM up to 1200 CFM can be supplied for extruder zone widths of 6" and longer. Consult Tempco with your requirements.

**All CFM Values are with free inlet and discharge and 0" Static Pressure. All Dimensions are in inches.**

Double Port Blower: Drawing 3

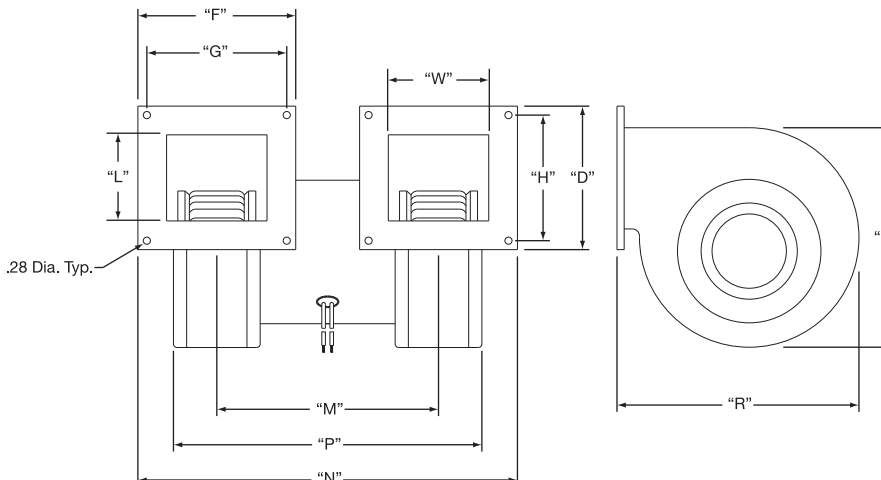

**Note:** A smaller 157 CFM version is also available. Special cast housing blowers rated 500 to 600 CFM for use on larger extruders can be obtained. Consult Tempco with your requirements.

## Installation Recommendations

### Installation Recommendations for Cast-In Thermal Components

Tempco Cast-In Heaters will provide long life and dependable, trouble-free service if properly installed, operated, and maintained as per the following recommendations:

#### Installation

1. Allow sufficient space for thermal expansion. The amount of space required depends upon the Cast-In Heater size, operating temperature and alloy.
2. Surface being heated must be free of any foreign materials and have a smooth finish.
3. Make sure that the casting is properly seated. The clamping devices used should be tightened down to the correct recommended torque. After initial heat-up, retighten fasteners to the correct recommended torque.

#### Recommended Torque:

10 ft-lb for 1/4–5/16 bolts, 20 ft-lb for 7/16–5/8 bolts

5. Thermal insulation can be used to reduce heat losses.
6. Avoid mounting heaters in an atmosphere containing combustible gases and vapors unless specifically manufactured for use in such conditions.
7. Liquid Cooled Cast-In Heater fittings must be securely tightened to prevent leaks.
8. To prevent overheating and heater failure, adequate temperature controls should be installed. For assistance in selecting temperature controls and thermocouples, see Tempco's (in-stock) complete line of Plug-In type Proportional Temperature Controls for heating and cooling applications in Section 13. Also see the listing on standard and hot melt thermocouples in Section 14.

#### Wiring

1. For connections at the heater terminals, use high temperature nickel conductor or nickel clad copper lead wire or alloy bus bar. Keep all electrical connections properly protected to eliminate electric shock to machine operators.
2. Heaters of equal wattage and voltage can be connected in series for higher voltage.
3. Heater installations must be properly grounded to eliminate electric shock hazard, and wiring must comply with electrical codes.
4. Always have a qualified electrician perform all wiring and connection of heaters and control components. Terminals must be tightened to the correct torque (2.5 ft/lb for terminal connections).

**CAUTION:** Castings are not designed to be lifted or carried by the terminations or leads.

**Exposed electrical wiring on cast-in heater installations is a violation of Electrical Safety Codes including O.S.H.A.**



**Note:** See page 16-11 for Wiring Diagrams and page 15-2 for lead wire selection

#### Operation

1. It is recommended to slow start the process during first use.
2. Do not operate above rated voltage. Excess voltage will result in heater failure.
3. Do not operate Cast-In Heaters above recommended temperatures. Heater temperature must be monitored and controlled. Use of over-temperature T/C is strongly recommended for higher temperature applications. Excess temperatures will result in heater failure and/or melting.
4. Electrical terminals must be kept free of contaminants, as spillage of plastic, water, oils, and their vapors can cause electric shorts, resulting in heater failure.
5. Liquid Cooled Cast-In Heaters must not be cycled to operate simultaneously. Thermal stresses may result in shorter heater life.
6. The water used on Liquid Cooled Cast-In Heaters must be properly treated. Hard water contains corrosive media that will contaminate the tubing, producing stress corrosion cracks and resulting in shorter heater life. Presence of minerals in water can cause clogged tubes that can result in poor heat transfer and eventually heater failure.

#### Maintenance

1. Never perform any type of service on heaters prior to disconnecting all electrical power.
2. To ensure good surface contact, periodically check clamping. Retighten clamping to the correct torque when required.
3. Repeat cycling of temperature controls can indicate poor surface contact or a burned-out heater.
4. Heater terminals must be kept free of plastics, oil, water, and any other foreign matter. As these materials carbonize, they create electrical shorts.
5. Heater terminal electrical connections must be kept tight. Loose connections can overheat and eventual destroy the connection or the heater terminal.
6. Water lines must be periodically checked for leaks. Water on heater terminals can be detrimental to the entire heating system.
7. Thermocouples must be kept free of contaminants and be checked for good response to temperature changes. Our recommendation is to change them periodically, as a bad thermocouple can be the cause of destroying an entire heating zone.

●●●●●●●● **Complete Your Installation With** ●●●●●●●●  
▼▼▼▼▼▼▼▼ **Accessories Available From Stock** ▼▼▼▼▼▼▼▼

Accessory	Catalog Section
* Stainless Steel Tubing and Fittings For Cooling Lines	3
* Pressure Transducers and Rupture Disks	12
* Temperature Controllers	13
* Temperature Sensors, Thermocouple Wire, Jacks & Plugs	14
* High Temperature Lead Wire & Fiberglass Tape, Ceramic Terminal Covers and Electric Plugs	15

**View Product Inventory @ [www.tempco.com](http://www.tempco.com)**