

Temperature Control

Thermostats

Thermostats are an optional feature on flanged immersion heaters. This type of control operates by expansion and contraction of a liquid in response to temperature change. Liquid contained within the sensing bulb and capillary flexes a diaphragm, causing the opening and closing of a snap action switch. For heating applications the contacts are normally closed and open on temperature rise.

Installation Warnings and Recommendations



1. **Do not use the thermostat as a power switch. Use some other means of disconnecting power to the heater for servicing.**
2. **A Thermostat is not a fail-safe device. Use an approved high temperature limit control and/or pressure limit control for safe operation.**
3. **Avoid kinking or bending the capillary tube too sharply as this will alter the calibration and/or render the thermostat inoperable.**
4. **Excess capillary tube should be coiled neatly in junction box.**
5. **The capillary tube must never touch the thermostat contacts as this will create an electrical short capable of harming personnel and/or equipment.**

Thermocouples

Type J or Type K thermocouples can be supplied for process temperature or over-temperature control. Type J is reliable and accurate for temperatures up to 1000°F (538°C). Type K should be used for higher temperatures.

For measuring process temperatures the thermocouple can be mounted in a thermowell in the center of the element bundle. Note that a location somewhere away from the heater may give a more accurate measurement of process temperature.

For over-temperature protection the thermocouple is usually attached to one of the elements (Figure A) and any unusual rise in element temperature would shut the heater down. This thermocouple may also be mounted in a thermowell (Figure B), which is then attached to one of the heating elements if desired. This protects the thermocouple from the solution being heated and allows you to replace it without removing the heater, but does increase its response time.

Temperature and over-temperature controls for using the signal generated by thermocouples and how to select the best control for your application can be found in Section 13.

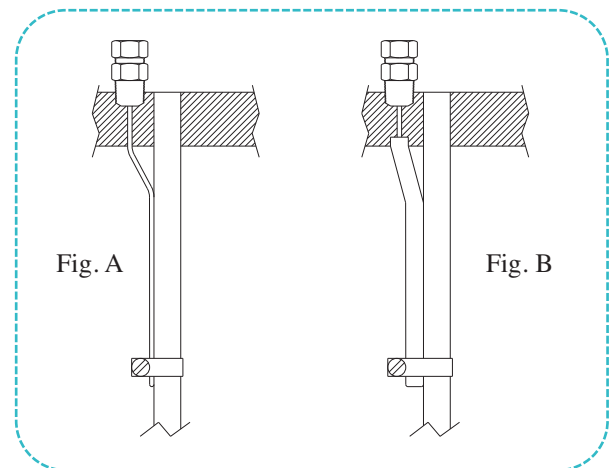

Series CHX-100, CHX-200 and CHX-300 Circulation Heaters — See Pages 3-12 through 3-17

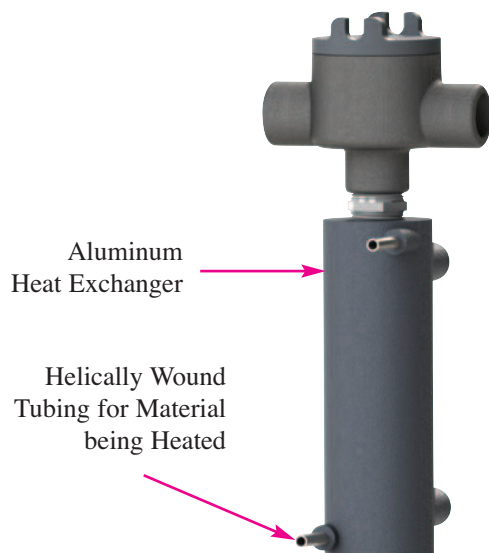

Construction

Series CHX circulation heaters are compact lightweight units used for heating gases or liquids. The material being heated is pumped through the coiled seamless 316 SS tubing which has been cast into an aluminum body which acts as the heat exchanger. A replaceable Hi-Density cartridge set into a hole bored into the aluminum is the heat source for the CHX-100, and a tubular heating element is the heat source for the CHX-200 and CHX-300. The material being heated never comes into contact with the heating element.

Circulation Heater Installation Recommendations

Tempco Circulation Heaters will have a long life and provide dependable, trouble-free service if properly installed, operated and maintained as per the following recommendations:

Installation

1. Flange heaters are supplied with two drilled and tapped holes for threaded eye bolts, providing ease of handling during installation and flange removal during maintenance cleaning or heater replacement.
2. Replacement of heater is inevitable. Therefore, provide adequate space for installation, allowing ample room to remove the flange heater for cleaning or replacement.
3. In applications requiring the circulation heater to be fed by an inline pump, install the pump at the inlet end.
4. To maintain the lowest possible temperature at the terminal box, place the outlet at the end opposite to the terminal box. If your process temperature is circulating at 450°F (232°C) or above (at the nozzle closest to the flange), stand-off terminal box construction is recommended.
5. To prevent temperature and/or pressure buildup on closed loop circulation heater systems, adequate and strategically located thermocouples for temperature controllers and pressure relief valves should be installed. Never over-rate pressure relief valves beyond the pressure temperature rating of the flange being used.
6. During the process cycle, flow rate of the medium being heated should never be interrupted or reduced, thus creating an overheating condition. Excess temperature can result in damage to the medium being processed and premature heater failure.
7. Make sure that your circulation heater is equipped with the proper terminal housing for the environment in which the heater is being used. NEMA 1—General purpose, NEMA 4—Moisture resistant, and NEMA 7—Explosion resistant.



Wiring

1. All heater installations must be properly earth grounded to eliminate electric shock hazard. Electrical wiring must be in accordance with Local and/or National Electrical Codes.
2. Circulation heaters are supplied standard with NEMA 1 terminal housings. All power to heaters must be disconnected before removing the terminal housing cover and performing any type of service.
3. Electrical connections on heater terminals must be kept tight. Loose connections will create arcing, over-heating, and eventually will destroy the heater terminal and cause premature heater failure.
4. If the amperage rating of your circulation heater exceeds the amperage capacity of the supplied thermostat, mercury relays or magnetic contactors should be used with the thermostat. See pages 13-92 through 13-96.
5. Over-temperature protection thermocouples require a separate conduit to the control panel for the thermocouple wire.
6. Tempco offers a large selection of Power Control Panels for circulation heaters. See pages 13-56 through 13-63.

Maintenance

1. Never perform any type of service on the unit prior to disconnecting all electrical power and shutting off all intake lines.
2. Remove sludge deposits through the drain plug.
3. Check flange bolts for tightness.
4. Check terminal connections for tightness.
5. Check thermocouple or thermostat bulb for response to temperature changes. If defective, replace immediately.
6. Check for leaks.
7. Depending on operating conditions and medium being processed, the flange or screw plug heater should be periodically removed for physical inspection and cleaning of the element bundle.

Vertical Mounting—Liquids

With terminal housing up and inlet pipe on the bottom, the heating elements will be immersed at all times to prevent premature failure.



Horizontal Mounting—Liquids and Gases

Always mount heater with inlet-outlet pipes facing up to ensure the heating elements will be immersed at all times to prevent premature failure. For liquid heating, outlet may be at either end. When heating gases the inlet should be closest to the terminal enclosure to minimize terminal box wiring temperatures.

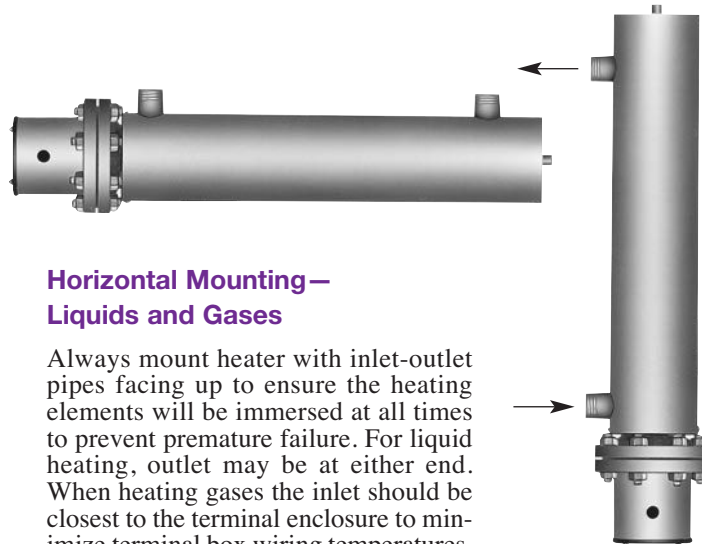

Vertical Mounting—Gases

Mount with terminal enclosure and inlet pipe at bottom of tank to minimize terminal box wiring temperatures.