

TPN FLANGE HEATERS WITH 6 SQUARE PATTERN ELEMENTS

TYPICAL WIRING – 6 SQUARE PATTERN ELEMENTS

SQUARE, ROUND OR RECTANGULAR MOUNTING FLANGE W/GASKET (9) INTERNAL BUSBARS & CROSSOVER WIRE. IF UNIT HAS T'STAT OR T'WELL, CENTER BAR REPLACED BY CROSSOVER WIRE.

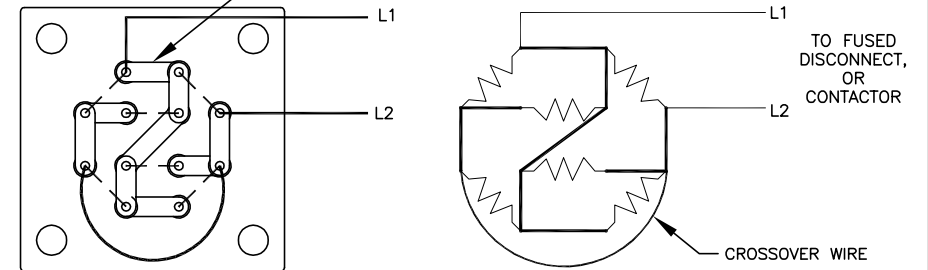

1 ϕ PARALLEL ELEMENTS
1 CIRCUIT

TO FUSED DISCONNECT, OR CONTACTOR

CROSSOVER WIRE

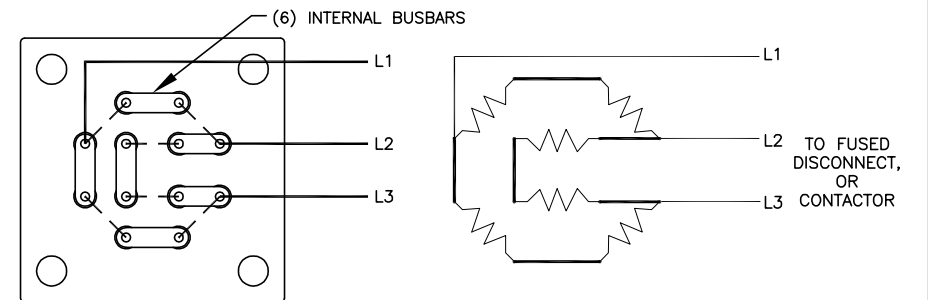

3 ϕ DELTA
2 SERIES ELEMENTS/ ϕ
(HIGH VOLTAGE CONNECTION FOR DUAL VOLTAGE HEATERS)

TO FUSED DISCONNECT, OR CONTACTOR

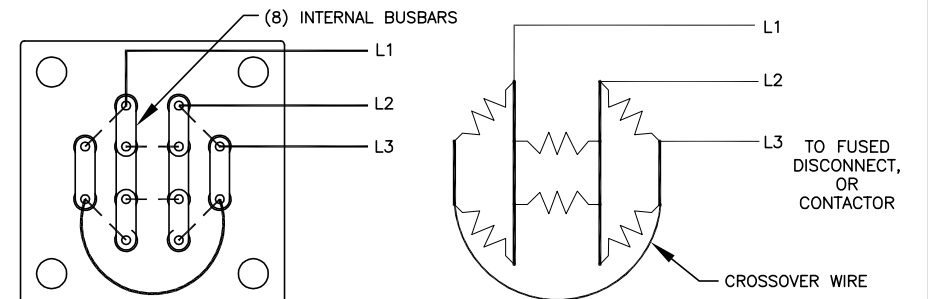

3 ϕ DELTA
2 PARALLEL ELEMENTS/ ϕ
(LOW VOLTAGE CONNECTION FOR DUAL VOLTAGE HEATERS)

TO FUSED DISCONNECT, OR CONTACTOR

CROSSOVER WIRE

LOW MEGOHM CONDITION

THE REFRACTORY MATERIAL USED IN ELECTRIC HEATERS MAY ABSORB MOISTURE DURING TRANSIT OR WHEN SUBJECTED TO A HUMID ENVIRONMENT FOR EXTENDED PERIODS. IF MOISTURE ABSORPTION RESULTS IN A COLD INSULATION RESISTANCE DOWN TO 10–15 MEGOHMS, THE HEATER WILL NORMALLY CORRECT ITSELF UPON A FIRST "SOFT START" HEATUP AND DOES NOT AFFECT HEATER EFFICIENCY OR LIFE. A LOW MEGOHM CONDITION CAN EASILY BE CORRECTED BY REMOVING THE TERMINAL ENCLOSURE, THERMOSTAT, AND TERMINAL HARDWARE AND BAKING THE HEATER IN AN OVEN AT 250° TO 300°F FOR SEVERAL HOURS, PREFERABLY OVERNIGHT. ALTERNATIVE PROCEDURE IS TO REMOVE THE THERMOSTAT AND ENERGIZE THE HEATER ELEMENTS AT LOW VOLTAGE UNTIL THE MEGOHM READING INCREASES TO AT LEAST 25–50 MEGOHMS. IF MEGOHM READING DOES NOT RISE PROPERLY, CONTACT TEMPACO FOR ASSISTANCE. WHEN ENERGIZING HEATERS IN AIR, THE SHEATH TEMPERATURES SHOULD NOT EXCEED 400°F FOR COPPER AND 750°F FOR STEEL OR INCOLOY ELEMENTS.

WIRING & INSTALLATION

1. LINE INPUT WIRING TO HEATER MUST BE INSTALLED AND SIZED FOR CURRENT CARRYING CAPACITY IN ACCORDANCE WITH THE NATIONAL ELECTRICAL CODE (NEC), NFPA 70/79, & LOCAL CODES. USE WIRES SUITABLE FOR AT LEAST 90C (194F). IF IN DOUBT, CONSULT A QUALIFIED ELECTRICIAN BEFORE WIRING OR CALL TEMPACO AT 800-323-6859.
2. IF ELEMENT WATTAGES OR VOLTAGE RATINGS ARE NOT EQUAL, HEATERS MUST NOT BE CONNECTED IN SERIES.
3. IF CORROSIVE OR HAZARDOUS VAPORS OR LIQUIDS ARE PRESENT, ELECTRICAL WIRING TO HEATER SHOULD BE ENCLOSED IN RIGID CONDUIT OR SEALED FLEXIBLE HOSE TO KEEP CONTAMINANTS OUT OF THE TERMINAL HOUSING. IF HIGH HUMIDITY IS ENCOUNTERED, THE CONDUIT & CONNECTIONS SHOULD SLOPE DOWN AND AWAY FROM THE HEATER.
4. IF FLEXIBLE CORD IS EMPLOYED, A WATERTIGHT CONNECTOR SHOULD BE USED FOR ENTRY OF THE CORD INTO THE TERMINAL BOX. OUTDOOR APPLICATIONS REQUIRE LIQUID-TIGHT CONDUIT AND CONNECTORS.
5. INSTALL POWER WIRING INTO TERMINAL HOUSING USING CONDUIT OPENING(S) PROVIDED WITH APPROVED STRAIN RELIEF CONNECTIONS. CONNECT LINE WIRES TO BUSSED TERMINALS AS SHOWN IN PROPER WIRING DIAGRAM.
6. BE SURE INSTALLATION IS PROPERLY GROUNDED THROUGH GROUNDING MEANS PROVIDED.

OPERATION & MAINTENANCE

1. DO NOT OPERATE HEATERS AT VOLTAGES IN EXCESS OF THAT STAMPED ON THE HEATER.
2. UL RECOGNIZED OIL HEATER DESIGNS, TO UL STANDARD 574 FOR OIL HEATERS, MUST NOT EXCEED 125C (257F) HEATED OIL TEMPERATURE IN APPLICATION & ARE NOT PRESSURE RATED UNDER THIS STANDARD. ELEMENTS USED IN TPN DESIGNS ARE ADDITIONALLY COVERED UNDER UL499 & UL1030 FOR GENERAL IMMERSION AND AIR APPLICATIONS.
3. ALWAYS MAINTAIN A MINIMUM OF 2" OF FLUID ABOVE THE HEATED AREA OF THE ELEMENT(S) WHEN USED FOR IMMERSION APPLICATIONS. IF THE HEATER IS NOT PROPERLY SUBMERGED, IT MAY OVERHEAT CAUSING A FIRE HAZARD AND SHORTEN HEATER LIFE. DO NOT OPERATE HEATER IF PARTIALLY SUBMERGED OR DRY. AIR HEATING APPLICATIONS REQUIRE EXTERNAL MEANS TO INSURE PROPER AIR FLOW IS PRESENT.
4. BLEED ALL TRAPPED AIR OUT OF HEATER CHAMBER & FLUID PIPING SYSTEM IN CLOSED IMMERSION SYSTEMS PRIOR TO ENERGIZING HEATER. SYSTEM MUST BE KEPT FILLED WITH FLUID (OR OIL) AT ALL TIMES WHEN HEATER IS ENERGIZED.
5. HEATER MUST BE INSTALLED IN A MANNER TO MINIMIZE EXCESSIVE SCALE BUILDUP ON ELEMENTS AND MOUNTED ABOVE SEDIMENT DEPOSITS.

OPERATION USING A THERMOSTAT(IF PROVIDED)

1. MAXIMUM THERMOSTAT TEMPERATURE SETTING (C/O POINT) FOR UL RECOGNIZED OIL HEATERS IS 250F (121C)
2. DO NOT USE A THERMOSTAT AS A POWER SWITCH. USE SOME OTHER MEANS OF DISCONNECTING POWER TO THE HEATER FOR SERVICING.
3. THERMOSTATS ARE NOT A FAIL-SAFE DEVICE. USE AN APPROVED TEMPERATURE LIMIT, PRESSURE/FLOW, OR LEVEL CONTROL FOR SAFE OPERATION IN SERIES WITH THE THERMOSTAT OR PREFERABLY ON A SEPARATE INDEPENDENT CIRCUIT.
4. WHEN INSTALLING A BULB/CAPILLARY STYLE T'STAT, AVOID KINKING OR BENDING THE CAPILLARY TUBE TOO SHARPLY AS THIS WILL ALTER THE CALIBRATION AND/OR RENDER THE THERMOSTAT INOPERABLE.
5. EXCESS CAPILLARY TUBE SHOULD BE COILED NEATLY IN JUNCTION BOX. THE CAPILLARY TUBE MUST NEVER TOUCH THE HEATER OR THERMOSTAT TERMINALS AS THIS WILL CAUSE AN ELECTRICAL SHORT CAPABLE OF HARMING PERSONNEL AND/OR EQUIPMENT.
6. SEE SPECIFIC INSTRUCTION SHEET FOR SPST OR DPST THERMOSTAT MODEL BEING INSTALLED.
7. IF HEATER VOLTAGE OR AMPERAGE EXCEEDS THERMOSTAT RATING, IT MUST BE CONNECTED TO OPERATE AN EXTERNAL CONTACTOR COIL AND NOT CONNECTED DIRECTLY IN LINE WITH HEATER. INSTALL PER PROPER WIRING DIAGRAM.

WARNING! HAZARD OF ELECTRIC SHOCK. DISCONNECT POWER BEFORE SERVICING OR INSTALLING HEATER. INSTALLATION MUST BE GROUNDED TO EARTH TO AVOID SHOCK HAZARD.

SEE REVERSE SIDE FOR
ADDITIONAL CIRCUIT WIRING
& THERMOSTAT SCHEMATICS

TITLE:		TPN FLANGE HEATER WIRING INSTRUCTIONS	
		6 ELEMENTS, SQUARE PATTERN DESIGN WITH & W/O THERMOSTAT	
		SHEET 1 of 2	
DRAWN BY:	APPROVED/REV:	DATE:	DRAWING NUMBER:
TJL	GDS	11/5/28/14	IDP-136-109



TEMPACO Electric Heater Corporation
607 N. Central Ave.
Wood Dale, IL 60191-1452 U.S.A.
Email: info@tempaco.com

TFP OIL HEATERS WITH 9 STAR PATTERN ELEMENTS

TYPICAL WIRING USING A DOUBLE POLE THERMOSTAT

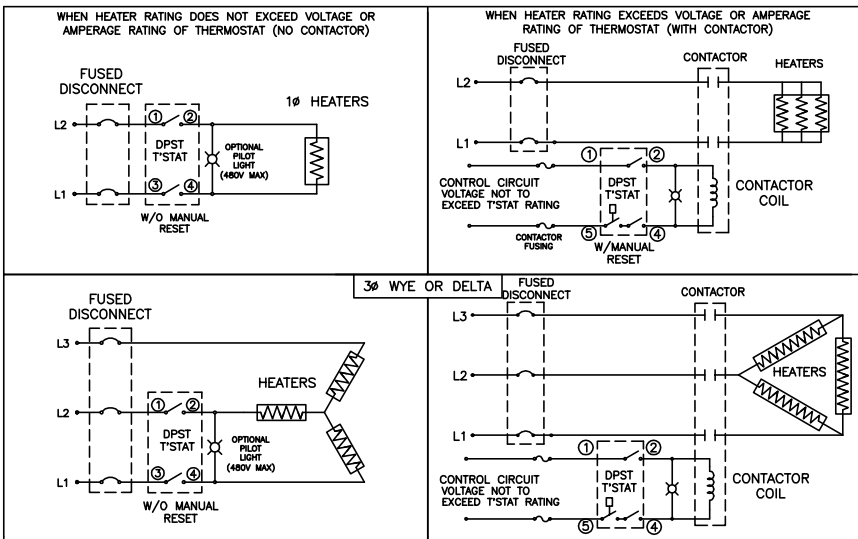

TYPICAL WIRING USING A SPST THERMOSTAT

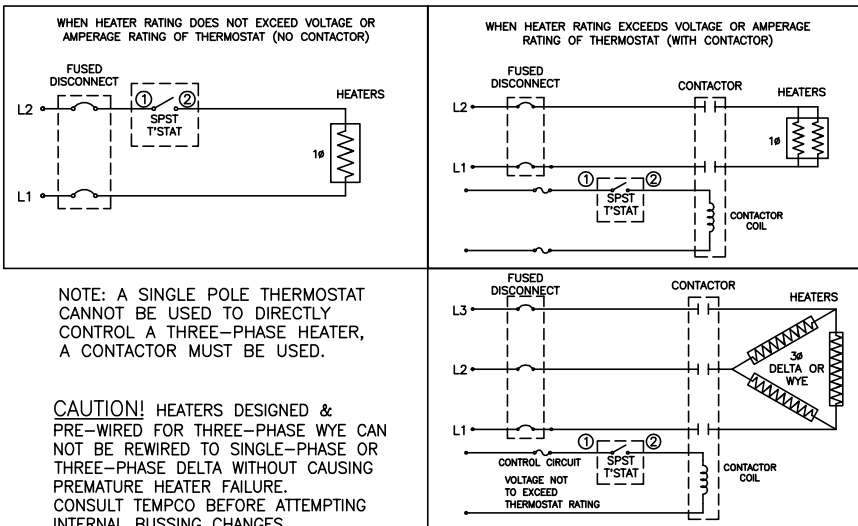

WARNING! HAZARD OF ELECTRIC SHOCK. DISCONNECT POWER BEFORE SERVICING OR INSTALLING HEATER. INSTALLATION MUST BE GROUNDED TO EARTH TO AVOID SHOCK HAZARD.

USED IN 5" SIZE FLANGE

3Ø DELTA
3 CIRCUITS
SINGLE ELEMENT/Ø

3Ø WYE
3 CIRCUITS
SINGLE ELEMENT/Ø

SINGLE Ø
3 CIRCUITS
3 PARALLEL
ELEMENTS/CIRCUIT

SEE REVERSE FOR ADDITIONAL
HEATER ELEMENT WIRING & BUSSING

TYPICAL WIRING - 9 STAR PATTERN ELEMENTS

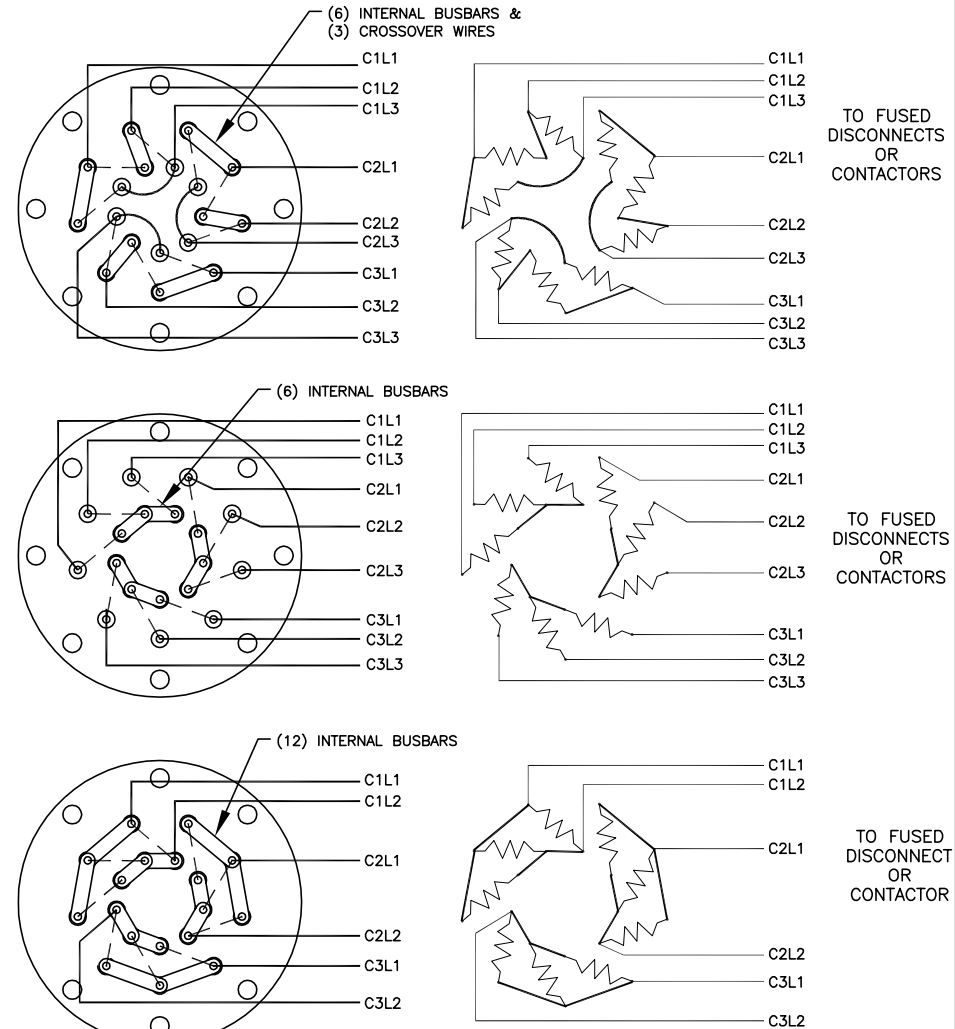

TITLE:
TFP HEATER WIRING INSTRUCTIONS
9 ELEMENTS
STAR PATTERN DESIGN
WITH AND WITHOUT THERMOSTATS
DRAWN BY: TJL | APPROVED: GDS | REV: 1 | DATE: 5/22/14 | DRAWING NUMBER: IDP-135-106

TEMPCO
WWW.TEMPCO.COM
TEMPCO Electric Heater Corporation
607 N. Central Ave.
Wood Dale, IL 60191-1452 U.S.A.
Email: info@tempco.com