

INTRODUCTION TO

Melt Pressure Transducers

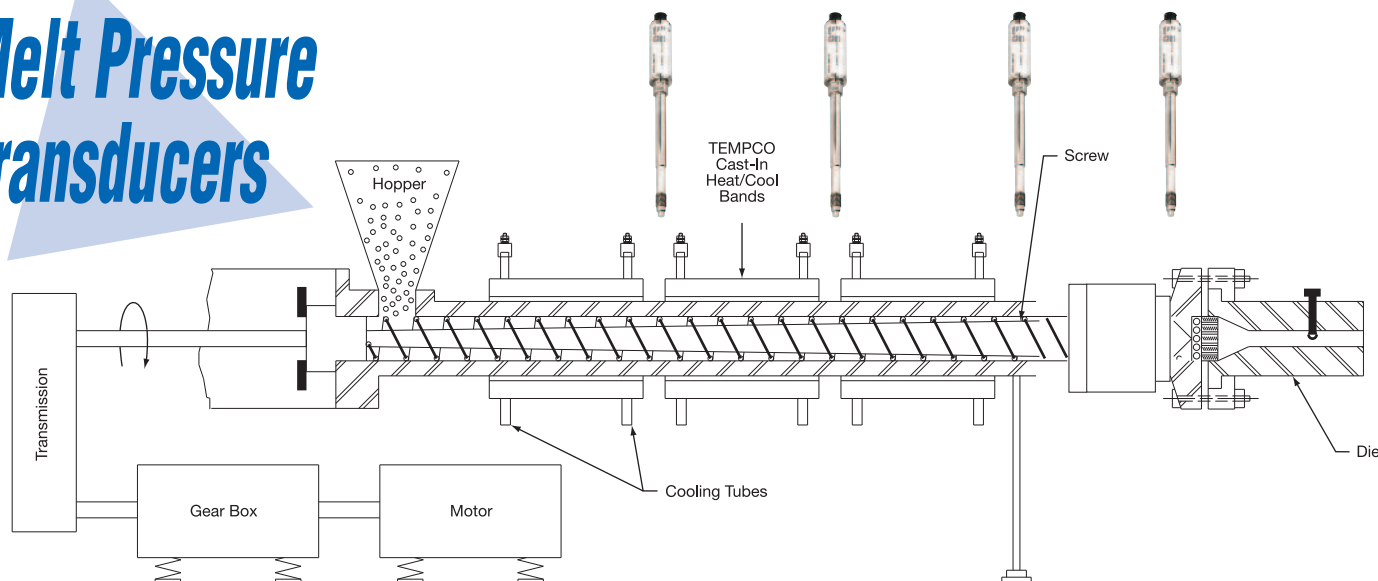

Designed for Maximum Operating Efficiency

Tempco Melt Pressure Transducers

are used to sense the pressure associated with the extrusion processing of plastic materials. They range in pressure from 0-500 PSI to 0-20,000 PSI with temperatures in the range of 70-750°F. Typical transducer outputs are 3.3 mV/V, 4-20 mA, 0-5 V, or 0-10 V (at full scale output).

APPLICATION

Plastic materials are formed to shape by a process defined as extrusion. This is accomplished by first softening the material with heat. Through the use of a drive screw, which is rotated by a motor, the material is forced toward and then through an opening, called a die, used to shape the plastic melt.

Various compounds, colorants and additives can be mixed with the plastic materials as they move along the screw path. The heated materials are shaped by the die and/or other post-extrusion equipment and then cooled to retain their shape.

WHERE AND WHY TRANSDUCERS ARE USED

Melt pressure transducers can be effectively used along many points of the extrusion process for a variety of reasons:

1. From a **quality control viewpoint**, a transducer should be located in the die. The measurement of the melt pressure at this point is used as an indication of flow rate.
2. To indicate when a **screen is in need of changing** and also to insure the safety of personnel and equipment alike, a transducer will be located somewhere ahead of the screen changer. This is most likely located either in the adapter or along the screw path within the barrel. An even more accurate determination of screen plugging can be made by reading the differential pressure between transducers located on either side of the screen, one being in the adapter, the other located in the barrel ahead of the screw tip.
3. For **research and development** purposes, Tempco transducers should be located at various points along the barrel in order to accurately monitor the pressure and mixing characteristics of the melt.
4. Transducers are also used for **pressure sensing on post-extrusion equipment** such as blow-molding heads, extrusion pumps and spinnerettes.
5. Locating transducers anywhere along the apparatus also serves to **improve the safety** of the extruder.

END PRODUCTS OF EXTRUSION PROCESS

The end results of the extrusion process can be found in various products. Some examples include:

1. The feedstock for other plastic packaging systems used for compounding and mixing.
2. Plastic film used to create bags and packaging materials.
3. Plastic tubing, hose, and pipe to contain water, gases or chemicals.
4. Insulated cable and wire housing.
5. Filaments used to create textiles, brushes, rope and twine.



Melt Pressure Transducer Data

Transducer and Gauge Standard Material Diaphragm and Options

The standard Tempco transducer diaphragm is machined out of a single piece of type 15-5 PH stainless steel (.0045") and then heat treated and finally Armoloy coated. This material gives Tempco transducers the transverse strength and toughness needed for most standard applications.

There are, however, certain extrusion processes that require different types of diaphragm materials and/or coatings. Tempco is able to supply customers with diaphragms and coatings specifically suited to their needs and applications.

HASTELLOY® TIP AND DIAPHRAGM

This option gives the transducer a Hastelloy® C-276 tip. This Hastelloy® tip extends along the stem and includes the 45° cone and threads. The diaphragm (.0045") is also manufactured of Hastelloy®. Hastelloy® should be used when the following chemicals are present in the process:

HCl	Hydrochloric Acid
HF	Hydrofluoric Acid
HBr	Hydrogen Bromide
HI	Hydrogen Iodide

For example, HCL is present when processing PVC and HF is present when processing Teflon®. If Hastelloy® is not used during these processes, the transducer diaphragm will fail prematurely due to stress cracks as a result of stress corrosion.

Recommended Use: Applications that are extremely corrosive.

SPECIAL DIAPHRAGM

Special 0.006" thick Inconel® diaphragm with a proprietary coating of Titanium Aluminum Nitride.

This special diaphragm is designed to be used in extremely abrasive environments. Superior to all other diaphragm materials for corrosion and abrasion resistance, examples of applications requiring this diaphragm option are ceramics or glass-filled nylon.

Recommended Use: Applications that are extremely abrasive.

INTERNAL RESISTANCE CALIBRATION TRACKING

An internal compensation circuit insures that the shunt calibration output will track any changes in pressure sensitivity (output) due to changes in temperature of the strain gauge housing. The simulated output, therefore, is 80%, ±0.25% of the full scale pressure output over the entire operating temperature range.

Film Adaptable for either blown process or slit casting, pressure monitoring can help produce thinner, more uniform film at faster process speeds. The pressure transducer also provides primary process information helpful for maximizing productivity and minimizing start-up scrap.

Synthetic Fibers Accurate, reliable pressure monitoring helps deliver greater consistency with less waste by reducing high speed variations, even with high performance fibers.

Wire Coating Pressure monitoring right in the crosshead die where the wire is coated with plastic insulation improves throughput, quality, and profits. This process parameter has become even more important as wire take-up systems go to higher and higher speeds.

Pipe, Tubing, and Profile A basic process parameter, pressure monitoring allows tighter tolerances, improves product quality and significantly improves cost effectiveness even for complex and multi-hollow extrusion.

CHROMIUM NITRIDE COATED DIAPHRAGM

The chromium nitride diaphragm option gives the transducer an advantage in abusive environments. The chromium nitride offers abrasion resistance and corrosion resistance. This is due to a phenomenon called reduced skin friction. This material will also cut down on diaphragm failures due to adhesion of melt to diaphragm during the process.

There are two different versions of this diaphragm option available. The first is a standard thickness (0.0045") diaphragm made of 15-5 PH stainless steel and then coated with a 0.0002" chromium nitride coating. This version is applicable for use in any pressure range plastic extruder. The second version is a 0.0080" thick diaphragm made of 15-5 PH stainless steel coated with a 0.0002" chromium nitride coating. This version is applicable for use in plastic extruders with pressure ranges of 7,500 PSI and up.

TITANIUM NITRIDE DIAPHRAGM

The titanium nitride diaphragm is offered for its excellent abrasion resistance. Its abrasion resistance is superior to the chromium nitride coated diaphragm and like the latter diaphragm the titanium nitride diaphragm comes in two different versions. The first is a standard thickness (0.0045") diaphragm made of 15-5 PH stainless steel and then coated with a 0.0002" titanium nitride coating. This version is applicable for use in any pressure range plastic extruder. The second version is a 0.0080" thick diaphragm made of 15-5 PH stainless steel coated with a 0.0002" titanium nitride coating. This version is applicable for use in plastic extruders with pressure ranges of 7,500 PSI and up.

INTERNAL RESISTANCE CALIBRATION

Tempco strain gauge sensors rely on the small change in resistance of each strain gauge to generate an analog signal that is proportional to the applied physical input. This resistance change is generated by straining a structural element to which the gauges are attached. The same output can be accomplished by electrically offsetting the resistance of one of the strain gauges through a simple shunt resistor network. This offsetting resistance network is built into each Tempco transducer.

During manufacturing, each Tempco transducer is pressure calibrated using highly accurate pressure sources and instrumentation. The signal output versus pressure input characteristic is thereby precisely known. The internal resistance network is adjusted so that the output generated by the shunt resistor simulation method matches precisely the calibrated output of the transducer at a selected point on its calibration curve. The standard simulation value is 80% of the full range rating of each transducer but other values may be chosen.

Applications of Melt Pressure Transducers

Pressure monitoring is a fundamental quality control technique used in modern extrusion processing. Typical applications include:



Melt Pressure Transducers

3 Styles of Melt Pressure Transducers for Extrusion Processing

Melt pressure transducers are specifically designed for accuracy, stability, and repeatability. They can be specified with a 0.5% or 0.25% combined error accuracy, a performance that equals or exceeds any other strain gauge melt pressure transducer on the market.

Design Features

- * *Stainless Steel Construction*
- * *Fully Interchangeable with all Existing Strain Gauge Melt Pressure Transducers*
- * *Fluid Filled System for Temperature Stability*
- * *80% Output Signal for Easy Calibration*
- * *Resistance Calibration Tracking*
- * *All Stainless Steel Construction*
- * *Armoloy-Coated Diaphragm*
- * *Compatible with all Strain Gauge Signal Conditioning & Readout Instrumentation*
- * *6- or 8-Pin Bendix Style Connectors available*
- * *CE Approved*



Rigid Stem Transducer

This model converts applied pressure at the point of measurement to a proportional voltage output signal using well established bonded strain gauge design principles. The small capillary tube, filled with a special medium, isolates sensitive strain gauges and electronics from potential thermal damage. The rigid stem makes installation fast and easy.

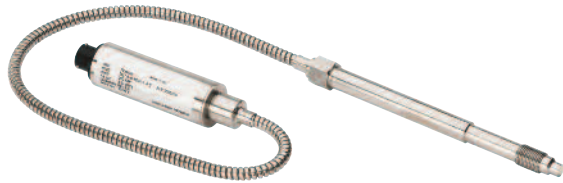
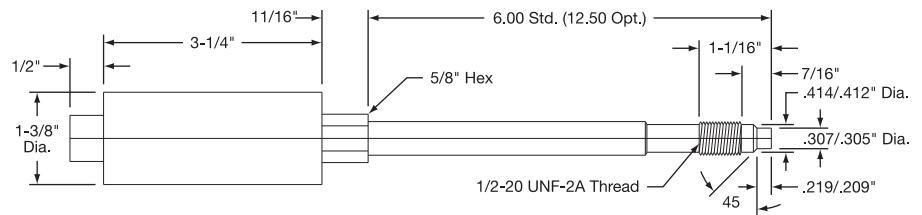

Flexible Armor Tubing Transducer

This model offers all the advantages of the rigid stem transducer, but incorporates an 18-inch flexible capillary tubing with a stainless steel armored jacket between the strain gauge housing and the stem.

This transducer is designed for applications requiring further thermal isolation or where installation would be otherwise difficult or impractical.

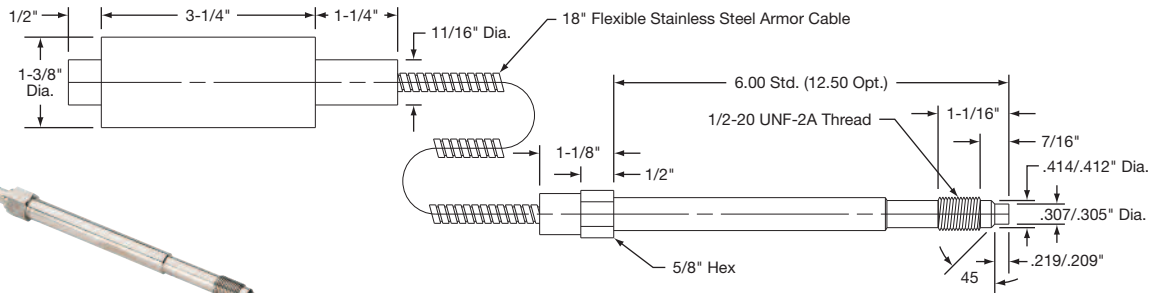

Pressure and Temperature Transducer

This model provides simultaneous measurement of pressure and temperature at a single point. Only one transducer mount is required for installation.

The temperature probe is protected from process hazards and can be replaced without interrupting the pressure signal. Pressure performance is identical to other models.

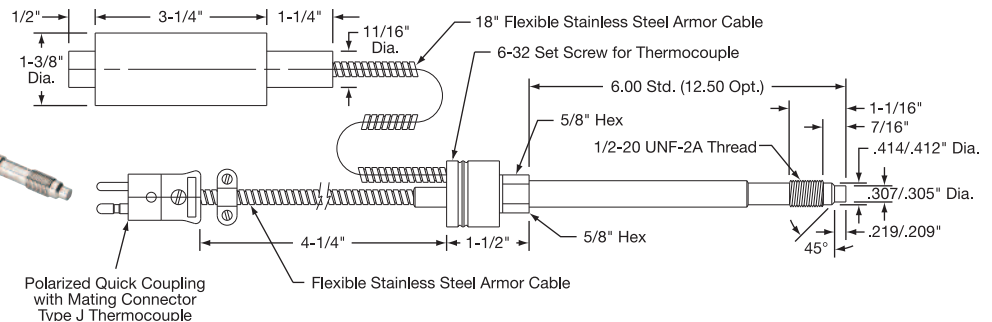



Melt Pressure Transducers for Extrusion Processing

DESIGN SPECIFICATIONS

Mechanical

Ranges

PSIG	BAR	PSIG	BAR	PSIG	BAR
0-500	0-35	0-3000	0-200	0-10000	0-700
0-750	0-50	0-5000	0-350	0-15000	0-1000
0-1000	0-70	0-7500	0-500	0-20000	0-1400
0-1500	0-100				

Combined Error/Error Band ±0.5% or ±0.25% of full-scale

Repeatability ±0.1% of full-scale

Hysteresis 0.1% of full-scale

Overload Capability Up to 20,000 PSIG: 2 × full-scale
Above 20,000 PSIG: 1.5 × full-scale

Mounting Torque 500 inch-pounds maximum

Diaphragm Material 15-5PH stn. stl. (Armoly plating)

Electrical

Measuring Element Strain gauge Wheatstone bridge

Element Resistance 350 ohm ±10%

Supply Voltage for 3.33 mV/V output, 6-12VDC (10VDC rec.)
for 4-20mA output, 12-30VDC (24VDC rec.)
for VDC output, 15-30VDC (24VDC rec.)

Zero Balance ±5.0% full-scale output

Internal Resistance Cali. (Factory Adjusted) Produces precise electrical signal which is 80% of full-scale within ±0.25%

Temperature on Strain Gauge Housing

Maximum Temperature 160°F or 70°C

Zero Drift 1.0%/100°F or 2.0%/100°C

Sensitivity Drift 1.0%/100°F or 2.0%/100°C

Temperature on Diaphragm

Max. Temp. (medium) 750°F or 400°C

Zero Shift 25 PSI/100°F or 45 PSI/100°C

Thermocouple (if ordered)

Thermocouple Type Type J

Connector Standard Size Male



Note: All temperature specifications relate to full-scale output or full pressure range output.

Standard Drill Pattern Specifications

D1	D2		D3		D4		A		B		C	
	in	mm	in	mm	in	mm	in	mm	in	mm	in	mm
1/2 - 20 UNF	.313 ± .001	7.95 ± .025	.454 ± .004	11.5 ± .10	.515 min	13 min	.225 min	5.7 min	.17 max	4.3 max	.75	19
M14 x 1.5	.319 ± .001	8.1 ± .025	.478 ± .004	12.1 ± .10	.630 min	16 min	.24 min	6.1 min	.16 max	4 max	.75	19
M18 x 1.5	.398 ± .01	10.1 ± .25	.634 ± .04	16.1 ± 1.0	.79 min	20 min	.24 min	6.1 min	.16 max	4 max	.99	25

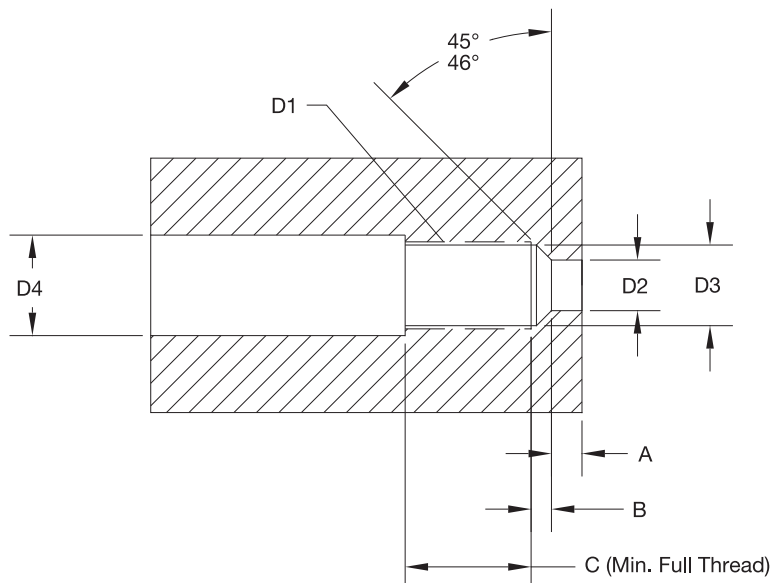



Melt Pressure Transducers

Melt Pressure Transducers Standard Sizes and Ranges

Style	Combined Error	Connector	Pressure Range	Output	Stem Length	Flex Length	Part Number
Rigid Stem	0.5% CE	6 Pin	0-5000	3.33 mV/V	6"	None	PDD00101
Rigid Stem	0.5% CE	6 Pin	0-7500	3.33 mV/V	6"	None	PDD00102
Rigid Stem	0.5% CE	6 Pin	0-10000	3.33 mV/V	6"	None	PDD00103
Rigid Stem	0.5% CE	6 Pin	0-15000	3.33 mV/V	6"	None	PDD00104
Rigid/Flex Armor	0.5% CE	6 Pin	0-5000	3.33 mV/V	6"	18"	PDD00105
Rigid/Flex Armor	0.5% CE	6 Pin	0-7500	3.33 mV/V	6"	18"	PDD00106
Rigid/Flex Armor	0.5% CE	6 Pin	0-10000	3.33 mV/V	6"	18"	PDD00107
Rigid/Flex Armor	0.5% CE	6 Pin	0-15000	3.33 mV/V	6"	18"	PDD00108
Rigid/Flex Armor with T/C	0.5% CE	6 Pin	0-5000	3.33 mV/V	6"	18"	PDD00109
Rigid/Flex Armor with T/C	0.5% CE	6 Pin	0-7500	3.33 mV/V	6"	18"	PDD00110
Rigid/Flex Armor with T/C	0.5% CE	6 Pin	0-10000	3.33 mV/V	6"	18"	PDD00111
Rigid/Flex Armor with T/C	0.5% CE	6 Pin	0-15000	3.33 mV/V	6"	18"	PDD00112

Ordering Code: **PDD** - 1 2 3 4 5 6 7 8 9 10

Style BOX 1

- A** = Rigid Stem
- B** = Flexible Armor Tubing
- C** = Transducer with Type J Thermocouple

Error Tolerance BOX 2

- 1** = 0.5% Combined Error (CE) (*Most Common*)
- 2** = 0.25% CE

Connector BOX 3

- S** = Six-Pin (*Most Common*)
- E** = Eight-Pin
- X** = Special

Pressure Range BOX 4

- | | |
|--------------------------------------|------------------------------------|
| A = 0-500 PSI (0.5% CE only) | L = 0-35 BAR (0.5% CE only) |
| B = 0-750 PSI (0.5% CE only) | M = 0-50 BAR (0.5% CE only) |
| C = 0-1000 PSI (0.5% CE only) | N = 0-70 BAR (0.5% CE only) |
| D = 0-1500 PSI | P = 0-100 BAR |
| E = 0-3000 PSI | Q = 0-200 BAR |
| F = 0-5000 PSI | R = 0-350 BAR |
| G = 0-7500 PSI | S = 0-500 BAR |
| H = 0-10000 PSI | T = 0-700 BAR |
| J = 0-15000 PSI | U = 0-1000 BAR |
| K = 0-20000 PSI | V = 0-1400 BAR |

Stem Length BOX 5

- 1** = 6 inches (*Most Common*)
- 2** = 12.5 inches
- 3** = 3 inches
- 0** = Other

Flex Length BOX 6

- 00** = None (Style A)
- 18** = 18 Inches* (Styles B & C)
- 24** = 24 Inches* (Styles B & C)
- 30** = 30 Inches* (Styles B & C)

*Other sizes can be made on special request.

Diaphragms BOX 7

- A** = Stainless Steel, 0.0045" (Standard) with GTP+ Coating 750°F/400°C
- B** = 0.0045" Hastelloy® 570°F/300°C
- C** = 0.0045" Chromium Nitride
- D** = 0.008" Chromium Nitride (7500 PSI & up only) 570°F/300°C
- E** = 0.006" Inconel with Titanium Aluminum Nitride 1000°F/538°C
- F** = 0.0045" Titanium Nitride
- G** = 0.008" Titanium Nitride (7500 PSI & up only) 1000°F/538°C
- X** = Other

Output BOX 8

- | | |
|---------------------------------|---------------------------|
| 0 = Custom | 3 = 0 to 5 Vdc |
| 1 = 3.33 mV/V (Standard) | 4 = 0 to 10 Vdc |
| 2 = 4 to 20 ma | 5 = 0.5 to 9.5 Vdc |

Capillary Fill Material BOX 9

- A** = Mercury (Standard) 750°F/400°C
- B** = Oil-FDA approved 600°F/315°C
- C** = NaK (Sodium Potassium) 1000°F/528°C

Thread BOX 10

- 1** = 1/2-20 (Standard)
- 2** = M18 x 1.5
- X** = Other

ADDITIONAL OPTIONS AVAILABLE...

Exposed Capillary Transducer: for applications requiring a transducer capable of fitting into extremely tight places.

Connectors (*consult Tempco if you require one of these options*)

Gentran GT-76 compatible wiring: strain gauge connector is wired for compatibility with Gentran GT-76 connector.

Barber Coleman TD10 compatible wiring: strain gauge connector is wired for compatibility with Barber Coleman TD10 connector.

Ordering Information

Melt Pressure Transducers are offered with the options listed in the worksheet above. Create an ordering code by filling in the boxes with the appropriate number and/or letter designation for your requirements and a part number will be assigned.

Part Numbers for commonly used Melt Pressure Transducers can be found in table above.

Standard lead time is stock to 3 weeks.

⚠ WARNING: Cancer and Reproductive Harm - www.P65Warnings.ca.gov.



Industry ~~CROSS~~ Reference Part Numbers

When using this cross reference please note that the box(□) in the Part Number is for the code for the pressure range. Since the pressure range differs from manufacturer to manufacturer, enter the code letter for the pressure range that best fits your application from **Pressure Range Box 4 on page 12-22**.

Also, though some equipment listed in this cross reference may differ in appearance, the fit and function of the products is equivalent.

NOTE: All transducers listed include 3.3mV/V output, mercury fill and 1/2-20 thread

Description	TEMPCO	Dynisco	ISI	Gefran	Gentran
Basic Melt Pressure Transducer with 0.5% Error, Armoloy Coated Tip and 6-Pin Connector					
6" Rigid stem	PDD-A1S□100A1A1	PT460E□-6	ISI 0100-□T-6	M30-6-M-□-1-4-0	GT-76/6D6□zb
6" Rigid stem with 18" flexible armor tubing	PDD-B1S□118A1A1	PT462E□-6/18	ISI 0101-□T-6/18	M31-6-M-□-1-4-D	GT-76/6D6Z1□
Above transducer with Type J thermocouple	PDD-C1S□118A1A1	TPT463E□-6/18	ISI 0102-□T-6/18	M32-6-M-□-1-4-D	GT-76/6JD6Z1□
Melt Pressure Transducer with 0.5% Error, Armoloy Coated Tip and 8-Pin Connector					
6" Rigid stem	PDD-A1E□100A1A1	n/a	ISI 0160-□T-6	M30-8-M-□-1-4-0	GT-76/6D8□
6" Rigid stem with 18" flexible armor tubing	PDD-B1E□118A1A1	n/a	ISI 0161-□T-6/18	M31-8-M-□-1-4-D	GT-76/6D8Z1□
Above transducer with Type J thermocouple	PDD-C1E□118A1A1	n/a	ISI 0162-□T-6/18	M32-8-M-□-1-4-D	GT-76/6JD8Z1□
Low Error Melt Pressure Transducer with 0.25% Error, Armoloy Coated Tip and 6-Pin Connector					
6" Rigid stem	PDD-A2S□100A1A1	PT420A-□-6	ISI 0110-□T-6	M30-6-H-□-1-4-0	GT-72/6D6□
6" Rigid stem with 18" flexible armor tubing	PDD-B2S□118A1A1	PT422A-□-6/18	ISI 0111-□T-6/18	M31-6-H-□-1-4-D	GT-72/6D6Z1□
Above transducer with Type J thermocouple	PDD-C2S□118A1A1	TPT432A-□-6/18	ISI 0112-□T-6/18	M32-6-H-□-1-4-D	GT-72/6JD6Z1□
Low Error Melt Pressure Transducer with 0.25% Error, Armoloy Coated Tip and 8-Pin Connector					
6" Rigid stem	PDD-A2E□100A1A1	n/a	ISI 0120-□T-6	M30-8-H-□-1-4-0	GT-72/6D8□
6" Rigid stem with 18" flexible armor tubing	PDD-B2E□118A1A1	n/a	ISI 0121-□T-6/18	M31-8-H-□-1-4-D	GT-72/6D8Z1□
Above transducer with Type J thermocouple	PDD-C2E□118A1A1	n/a	ISI 0122-□T-6/18	M32-8-H-□-1-4-D	GT-72/6JD8Z1□
Mechanical Melt Pressure Gauge					
6" Rigid stem	PDG-A1□100A1A1	PG441R-□-6	ISI 0150-□T-6	M50-0-L-□-1-4-0	GT-90/6D□
6" Rigid stem with 18" flexible armor tubing	PDG-A2□130A1A1	PG442R-□-6/30	ISI 0151-□T-6/30	M51-0-L-□-1-4-F	GT-95/6Z3□
Above gauge with Type J thermocouple	PDG-A3□130A1A1	TPG443R-□-6/30	ISI 0152-□T-6/30	M52-0-L-□-1-4-F	GT-95/6JZ3□
Digital Melt Pressure Gauge					
6" Rigid stem	PDG-B1□100A1A1	PG541-□-6	n/a	M60-0-L-□-1-4-0	n/a
6" Rigid stem with 18" flexible armor tubing	PDG-B2□130A1A1	PG552-□-6/30	n/a	M61-0-L-□-1-4-F	n/a
Above gauge with Type J thermocouple	PDG-B3□130A1A1	TPG553-□-6/30	n/a	M62-0-L-□-1-4-F	n/a



Melt Pressure Gauges

Melt Pressure Gauge Styles for Extrusion Processing

Tempco's Melt Pressure Gauges provide highly reliable, maintenance free, local pressure indications for extrusion and other plastics processes. The sensing diaphragm is designed for minimum deflection, maximum durability, and maximum overload capability.

Two models are available with three styles each:

- Mechanical Gauge Model
- Digital Gauge Model with alarm and retransmission

Style 1 A 6" rigid stem unit for standard installations

Style 2 A 30" flexible capillary with stainless steel armored jacket between the gauge housing and the stem to allow greater installation flexibility in tight places or for easier viewing and durability.

Style 3 The third style provides all the features of the 30" flexible capillary model with the addition of a thermocouple (J-type) output for temperature. (Not displayed directly on digital models.)

All models are rugged, totally self contained and allow extrusion processors to benefit from the significantly improved efficiency that goes with pressure monitoring—at about half the cost of strain gauge melt pressure transducers for the mechanical gauge.

Optional diaphragm materials are available for applications that require extra abrasion and/or corrosion resistance. Refer to page 12-19 for available material options.

Mechanical Melt Pressure Gauge



Rigid Stem Style Shown

Design Features

- * No Power (or Wiring) Required
- * No Maintenance, No Grease
- * Electron Beam Welded
- * 150% Overload Capability without Damage
- * Greater than 180° Movement for Optimum Readability
- * Stainless Steel Construction
- * 5.44"/138.2mm Diameter Face
- * An Economical Alternative for Many Applications

Specifications

Linearity, Repeatability, Hysteresis: $L < \pm 1.0\%$ FSO

Measurement Range: 0-5000 PSI / 0-350 bar to 0-10000 PSI / 0-700 bar

Maximum overpressure: $1.5 \times$ FSO

Measurement principle: Bourdon tube

Maximum housing temperature: . . . 185°F / 85°C

Maximum diaphragm temperature: . 750°F / 400°C

Standard diaphragm material: 15-5 PH Stainless Steel with Armoloy coating

Standard style 3 thermocouple: . . . Type J (isolated junction)

Digital Melt Pressure Gauge



Rigid Stem Style Shown

Design Features

- * Better than $\pm 0.50\%$ Accuracy
- * Economically Priced vs. Separate Transducer and Display
- * Electron Beam Welded
- * 200% Overload Capability without Damage
- * 15-5 Stainless Steel Diaphragm with Armoloy coating standard
- * Alarm Provides no/nc, 5A 115/240Vac High Pressure Only Relay
- * 115 VAC standard, 230 VAC Optional
- * 5.44"/138.2mm Diameter Face
- * An Economical Alternative for many Applications
- * Standard 4-20 mA Retransmission

Specifications

Linearity, Repeatability, Hysteresis: $M < \pm 0.50\%$ FSO

Measurement Range: See ordering chart

Maximum overpressure: $2 \times$ FSO

Measurement principle: Strain gauge / bridge circuit

Power supply: 115 or 220 VAC (factory set)

Pressure retransmission: 4-20 ma (650Ω max. load)

Maximum housing temperature: . . . 130°F / 55°C

Maximum diaphragm temperature: 750°F / 400°C

Standard diaphragm material: 15-5 PH Stainless Steel with Armoloy coating

below 1000 PSI/70 bar: 17-7 PH SS Ti Ni coated

Standard style 3 thermocouple: . . . Type J (isolated junction)

Alarm: High only, no/nc, 5A 115/240Vac



Melt Pressure Gauges Standard Sizes and Ranges

Mechanical Gauges

Part Number	Style	Pressure Range
PDG00104	6" Rigid Stem	0-5000
PDG00105	6" Rigid Stem	0-10000
PDG00102	6" Rigid/30" Armor Cable	0-5000
PDG00103	6" Rigid/30" Armor Cable	0-10000
PDG00106	6" Rigid/30" Armor Cable with J tc	0-5000
PDG00107	6" Rigid/30" Armor Cable with J tc	0-10000

Digital Readout Gauges

Part Number	Style	Pressure Range
PDG00501	6" Rigid Stem	0-5000
PDG00502	6" Rigid Stem	0-10000
PDG00503	6" Rigid/30" Armor Cable	0-5000
PDG00504	6" Rigid/30" Armor Cable	0-10000
PDG00505	6" Rigid/30" Armor Cable with J tc	0-5000
PDG00506	6" Rigid/30" Armor Cable with J tc	0-10000



Note: All standard flexible armor cable over the pressure sense capillary include a 6" rigid stem and 30" of flexible armor. If a type J thermocouple is specified, a standard size type J plug is provided, similar to the Melt Pressure Transducer shown on page 12-20.

Gauges have standard 1/2-20 UNF drill pattern; see page 12-21.

Ordering Code: **PDG** - ¹ ² ³ ⁴ ⁵

Model and Style BOX 1

- A1** = Mechanical, Rigid Stem
- A2** = Mechanical, Rigid + Flexible Armor Tubing
- A3** = Mechanical gauge with Type J Thermocouple
- B1** = Digital, Rigid Stem
- B2** = Digital, Rigid + Flexible Armor Tubing
- B3** = Digital Gauge with Type J Thermocouple

Stem Length BOX 3

- 1** = 6 inches (*Most Common*)
- 2** = 12.5 inches

Flex Length BOX 4

- 00** = None (*Styles A1 & B1*)
- 30** = 30 Inches*

*Other sizes can be made on special request.

Pressure Range BOX 2

Mechanical

- | | |
|--------------------|------------------|
| PSI | Bar |
| A = 0-5000 | C = 0-350 |
| B = 0-10000 | D = 0-700 |

Digital - PSI

- | | |
|--------------------|-------------------|
| A = 0-500 | L = 0-35 |
| B = 0-750 | M = 0-50 |
| C = 0-1000 | N = 0-70 |
| D = 0-1500 | P = 0-100 |
| E = 0-3000 | Q = 0-200 |
| F = 0-5000 | R = 0-350 |
| G = 0-7500 | S = 0-500 |
| H = 0-10000 | T = 0-700 |
| J = 0-15000 | U = 0-1000 |

Diaphragms BOX 5

Standard Diaphragm Construction

A = Stainless Steel (.0045") with Armoloy coating (*Most Common*)

Optional Materials and Coatings

- | | |
|------------------------------------|---|
| B = 0.0045" Hastelloy® | E = 0.006" Inconel® with Titanium Aluminum Nitride |
| C = 0.008" Chromium Nickel | F = 0.0045" Titanium Nitride |
| D = 0.0045" Chromium Nickel | G = 0.008" Titanium Nitride |



Note: All digital gauges have one alarm and pressure retransmission.

Ordering Information

Melt Pressure Gauges are offered with the options listed in the worksheet above. Create an ordering code by filling in the boxes with the appropriate number and/or letter designation for your requirements and a part number will be assigned.

Part Numbers for commonly used Melt Pressure gauges can be found in table above.

Standard lead time is stock to 3 weeks.

WARNING: Cancer and Reproductive Harm - www.P65Warnings.ca.gov.



Melt Pressure Display and Alarm Indicators For Extrusion



Design Features

- * 1/8 DIN Size Front Panel
- * 2 Alarms, Programmable Relay Outputs
- * ISO 9001 Certified, CE Approved
- * Economically Priced
- * 4-Digit LED Display for Pressure
- * 3 Keys for Programming
- * Touch-Type Keypad
- * Easy to Calibrate with Sensitivity Auto Ranging
- * Built-In Strain Gauge Bridge Excitation – 10Vdc
- * Filter for Digit Stabilization
- * Coded Access for User Lockout

Model Number: PDA05010

Series **772** Melt Pressure Indicator



Design Features

- * 1/4 DIN Size Front Panel
- * NEMA 4X - IP65 Front Panel Protection
- * 10-point Red LED Bar Graph
- * ISO 9001 Certified, CE Approved
- * 2 Alarms, Programmable Relay Outputs
- * Calibration Output
- * Retransmission – Programmable for 0 - Vdc, 0 - 20 or 4 - 20mA
- * Multiple Programming Levels with Coded Access
- * Peak Value Memory
- * 4-Key Touch-Type Keypad
- * Built-In Strain Gauge Bridge Excitation – 10Vdc
- * Filter for Digit Stabilization
- * RS-232 & RS-485 Communication Available; Consult Factory for More Information

Model Number: PDA05020

Series **882** Melt Pressure Indicator



Design Features

- * 1/4 DIN Size Front Panel
- * Displays Pressure & Temperature Simultaneously on two 4-Digit LED Displays
- * ISO 9001 Certified, CE Approved
- * NEMA 4X - IP65 Front Panel Protection
- * 2 Alarms with Adjustable Setpoint for Temperature or Pressure
- * Calibration Output
- * Retransmission – Programmable for 0 - Vdc, 0 - 20 or 4 - 20mA
- * 10-point Red LED Bar Graph
- * Multiple Programming Levels with Coded Access
- * 4-key Touch-Type Keypad
- * Built-In Strain Gauge Bridge Excitation – 10 Vdc
- * Filter for Digit Stabilization
- * RS-232 & RS-485 Communication Available; Consult Factory for More Information

Model Number: PDA05030

Series **992** Melt Pressure and Temperature Indicator



Melt Pressure Display and Alarm Indicators For Extrusion

SPECIFICATIONS			
Part Number:	772 Series – 1/8 DIN PDA05010	882 Series – 1/4 DIN PDA05020	992 Series – 1/4 DIN PDA05030
Electrical			
Power:	120 Vac \pm 10% or 230 Vac \pm 10% (50/60 Hz) Optional: 11-27 Vac/Vdc for PDA05010 and 20-27 Vac/Vdc for PDA05020/PDA05030		
Operating Temp.:	+32°F to +130°F (0° to 55°C)		
Noise Immunity:	VDE 0843 & IEC 801		
Fascia Seal Rating:	N/A	NEMA 4X – IP65	
Termination:	Screw clamp terminals		
Signal Input			
Type:	350 Ω strain gauge bridge		
Input Sensitivity:	3.3 mV/V	1.5 to 7.5 mV/V	
Accuracy:	\pm 0.2% of full scale \pm 1 digit		
Sensor Excitation:	10 Vdc @ 120 mA		
Calibration:	Will accept transducers with internal shunt calibration values from 40%–100% or external calibration resistors		
Housing	1/8 DIN (48 x 96 x 160 mm)	1/4 DIN (96 x 96 x 160 mm)	
Panel Cutout	1.75 x 3.62 in. (44.5 x 92 mm)	3.62 x 3.62 in. (92 x 92 mm)	
Display			
Type:	4-digit LED display	Two 4-digit LED displays Red: Pressure Green: Temperature	
Ranges:	User programmable for pressure and temperature: –999 to +9999		Pressure: –999 to +9999 Temperature: Standard T/C limits
Units:	PSI, kg/cm ² , BAR, kPa, Pa, MPa	PSI, kg/cm ² , BAR, °F, °C	
Decimal:	Selectable from keyboard		
Setup Prompts:	Displays program steps and error conditions		
Alarms			
Type:	2 SPDT: In the event of a power failure relays go into alarm condition		
Mode:	Absolute, relative with direct or inverse functions can be set via front panel keyboard		
Set Point Range:	0-100% full scale		
Hysteresis:	Configurable per output		
Contact Rating:	5A @ 250 Vac for each alarm output		
Auxiliary Output			
Retransmission:	N/A	0-10 Vdc or 0/4-20mA	
Resolution:	N/A	4000 steps	
Isolation:	N/A	1500V	

Ordering Information:

Order by the part number of the display that meets your requirements.

Standard lead time is stock to 3 weeks.

⚠ WARNING: Cancer and Reproductive Harm - www.P65Warnings.ca.gov.

(800) 323-6859 • Email: sales@tempco.com



Melt Pressure Transducer Kits

Melt Pressure Transducer Packages

Melt Pressure Transducer Packages

Special Melt Pressure Transducer Packages have been prepared by Tempco for sale at a discounted price. These packages contain all the components necessary for monitoring your extruder melt pressures.

The package contains:

- One [1] .5% combined error 6" rigid stem MELT PRESSURE TRANSDUCER and a standard Armoloy diaphragm tip in a variety of pressure ranges (see table below)

OR

One [1] 18" flexible armor cable MELT PRESSURE TRANSDUCER with a 6-pin connector, 6" stem length, and a standard Armoloy diaphragm tip in a variety of pressure ranges (see table below)

- One [1] model 772 MELT PRESSURE INDICATOR
- One [1] 25-foot-long TRANSDUCER CABLE assembly for a 6-pin connector



DISCOUNT PACKAGE		
Part Number		
Transducer Style		Pressure Range (psi)
Rigid/Flex	Rigid Only	
PDA05101	PDA05201	0-500
PDA05102	PDA05202	0-750
PDA05103	PDA05203	0-1000
PDA05104	PDA05204	0-1500
PDA05105	PDA05205	0-3000
PDA05106	PDA05206	0-5000
PDA05107	PDA05207	0-7500
PDA05108	PDA05208	0-10000
PDA05109	PDA05209	0-15000
PDA05110	PDA05210	0-20000

Ordering Information

Order by the part number of the product that meets your requirements. **Standard lead time is stock to 3 weeks.**

ACCESSORIES – Connectors and Cable Assemblies

6-and 8-Pin Transducer Cables

These connectors and cable assemblies are designed to be compatible with the 6-pin and 8-pin connectors used on Tempco's line of melt pressure transducers.

The cable assemblies come with a female connector on one end to connect to the transducer, and the other end has 6 or 8 braided wire leads to connect to input and output sources, displays or controllers.

The transducer mating connector offered is the female mating connector with no cable or wiring attached.

Thermocouple Cables

The cable assemblies and connector are designed to be compatible with the connectors used on Tempco's line of melt pressure transducers with Type J thermocouples.

The cable assemblies come with a Type J female connector on one end to mate with the Transducer/Thermocouple assembly and leads on the other end.

The mating connector offered is a Type J two-pin female connector designed to mate with the male thermocouple connector on the Transducer/Thermocouple assembly.

TRANSDUCER MATING CONNECTORS (hardware only)

6-Pin Part Number	8-Pin Part Number
PDA00215	PDA00213

THERMOCOUPLE MATING CONNECTOR Standard Size, Female Type J

Part Number
TCA-102-101

THERMOCOUPLE CABLE ASSEMBLIES

Size	Part Number
25 feet	ECA00057
50 feet	ECA00058
75 feet	ECA00059
100 feet	ECA00060

TRANSDUCER CABLE ASSEMBLIES

Size	6-Pin Part Number	8-Pin Part Number
10 feet	PDA00216	—
25 feet	PDA00201	PDA00205
50 feet	PDA00202	PDA00206
75 feet	PDA00203	PDA00207
100 feet	PDA00204	PDA00208

GENERAL ACCESSORIES

Description	Part Number
3-Piece Cleaning Tool Kit (1/2-20 thread)	PDA00251
Transducer Mount Drill Kit	PDA00253
Transducer Pressure Simulator—6-Pin	PDA00254
Transducer Pressure Simulator—8-Pin	PDA00255
Mounting Bracket	PDA00256