

Temperature Controllers



Model TEC-2500 1/32 DIN

Model TEC-2500 1/32 DIN Temperature Controller



Configurable for 4 Programmable Outputs!

Agency Approvals: RoHS



File #:
E244198

Design Features

- * 1/32 DIN size – 24 mm × 48 mm
- * Fuzzy Logic PID Autotune heat & cool control
- * Short panel depth – only 3-7/8" (98 mm) required
- * Universal input, field configurable (Type J T/C default, PT100, mA, V) with high accuracy 18-bit D-A
- * Heater Break Alarm using 0-50 Amp current transformer
- * Output 2 can be programmed as output or alarm
- * NEMA 4X / IP65 gasketed front panel
- * Alarm 1 – programmable 5 VDC logic output
- * Universal input power, 90-264 VAC or 11-26 VAC/VDC
- * Bumpless transfer to manual mode during sensor failure
- * Power limiter output
- * Wide variety of alarm mode selections
- * RS-485 and RS-232 data communications interface
- * Bright 0.40" (10 mm) LED display
- * Fast input sample rate (5 samples/second)
- * Automatic programming
- * Differential control
- * "Soft-Start" ramp and dwell timer
- * Analog input for remote setpoint and current transformer
- * Event input for changing functions and setpoint
- * Hardware lockout plus remote lockout protection
- * Loop break alarm
- * Analog retransmission
- * DC power supply outputs
- * High performance at a low price

Hardware Code: TEC-2500-



A Part Number based on the hardware code and any software pre-programming will be issued at time of order.

Power Input BOX 1

- 4 = 90-264 VAC
- 5 = 11-26 VAC / VDC
- 9 = Other

Signal Input – Universal, can be programmed in the field BOX 2

- 1 = Input 1 – Universal input (factory default = tc type J)
Thermocouple: J, K, T, E, B, R, S, N, L
RTD: PT100 DIN, PT100 JIS
Current: 4-20 mA, 0-20 mA
Voltage: VDC, 0-1, 0-5, 1-5, 0-10
- Input 2 – not available if RS-232 is specified
CT: 0 - 50A AC current Transformer (factory default)
Voltage Input: 0-1V, 0-5V, 1-5V, 0-10V
Event Input
- 9 = Other

Output 1 BOX 3

- 1 = Relay: 2A / 240 VAC
- 2 = Pulse DC for SSR drive: 5 VDC (30 mA max)
- 3 = Isolated, 4-20 mA (default), 0-20 mA
- 4 = Isolated, VDC, 1-5 (default), 0-5, 0-1
- 5 = Isolated, VDC, 0-10
- 6 = Triac-SSR output 1A / 240 VAC
- C = Pulse DC for SSR drive: 14 VDC (40 mA max)
- 9 = Other

Output 2 / Alarm 2 BOX 4

- 0 = None
- 1 = Relay: 2A / 240 VAC
- 2 = Pulse DC for SSR drive: 5 VDC (30 mA max)
- 3 = Isolated, 4-20 mA (default), 0-20 mA
- 4 = Isolated VDC, 1-5 (default), 0-5, 0-1
- 5 = Isolated VDC, 0-10
- 6 = Triac-SSR output 1A / 240 VAC
- 7 = Isolated 20V @ 25 mA DC, Output Power Supply
- 8 = Isolated 12V @ 40 mA DC, Output Power Supply
- 9 = Isolated 5V @ 80 mA DC, Output Power Supply
- C = Pulse DC for SSR drive: 14 VDC (40 mA max)
- A = Other

Alarm 1 BOX 5

- 1 = 5 VDC Logic Output
- 9 = Other

Communications BOX 6

- 0 = None
- 1 = RS-485 Interface
- 2 = RS-232 Interface
- 3 = Retransmission 4-20 mA (default), 0-20 mA
- 4 = Retransmission 1-5 VDC (default), 0-5 VDC
- 5 = Retransmission 0-10 VDC
- 9 = Other

Units – °F or °C BOX 7

- 1 = °F on faceplate
- 2 = °C on faceplate
- 3 = None (process units)



Note: Detailed information on features common to digital microprocessor-based TEC temperature controls and the complete Table of Input Range and Accuracy can be found on page 13-46.

Transformer for Heater Break Alarm

(0-50 Amp current)

Part Number: TEC99999

Specifications on page 13-47



Power Input

Standard: 90-264 VAC, 47-63 Hz, 15 VA, 7W maximum
Optional: 11-26 VAC / VDC, 15 VA, 7W maximum

Signal Input

Input 1

Resolution: 18 bits **Sampling Rate:** 5 samples / second
Accuracy: $\pm 0.24\%$ of span typical
Maximum Rating: -2 VDC minimum, 12 VDC maximum (1 minute for mA input)
Temperature Effect: $\pm 1.5 \mu V / ^\circ C$ for all inputs except mA input $\pm 3.0 \mu V / ^\circ C$ for mA input

Sensor Lead Resistance Effect: T/C: $0.2 \mu V / \text{ohm}$
 3-wire RTD: $2.6^\circ C / \text{ohm}$ of resistance difference of two leads
Burn-out Current: 200nA

Common Mode Rejection Ratio (CMRR): 120 dB
Normal Mode Rejection Ratio (NMRR): 55 dB

Sensor Break Detection: Sensor open for TC, RTD and mV inputs; sensor short for RTD input; below 1 mA for 4-20 mA input; below 0.25V for 1-5V input; unavailable for other inputs

Sensor Break Response Time: Within 4 seconds for TC, RTD and mV inputs; 0.1 second for 4-20 mA and 1-5 V inputs

Input 2

Resolution: 18 bits
Sampling Rate: 1.66 times per second
Sensor Break Response Time: 0.5 second
Types: **Current Transducer:** 0 to 50 Amp
mA: -3 to 27 mA **V:** -1.3 to 11.5 VDC

Event Input Functions: Select 2nd setpoint and/or PID, disable output 1 and/or output 2, remote lockout, reset alarm 1 and/or alarm 2

Output 1 or Output 2 / Alarm 2

Relay Rating: 240 VAC, 2 Amp
Pulsed Voltage: Source voltage 5V,
 Current limiting resistance 66 Ω

Linear Output — Characteristics

Type	Zero Tolerance	Span Capacity	Load
4-20 mA	3.6-4.0 mA	20-21 mA	500 Ω max
0-20 mA	0 mA	20-21 mA	500 Ω max
0-5 VDC	0 VDC	5-5.25 VDC	10 K Ω min
1-5 VDC	0.9-1.0 VDC	5-5.25 VDC	10 K Ω min
0-10 VDC	0 VDC	10-10.5 VDC	10 K Ω min

Resolution: 15 bit analog to digital converter

Isolation Breakdown Voltage: 1000 VAC

Solid State Relay (Triac) Output

Rating: 1A / 240 VAC **Inrush Current:** 20A for 1 cycle
Min. Load Current: 50 mA rms
Max. Off-state Leakage: 3 mA rms
Max. On-state Voltage: 1.5 VAC rms
Insulation Resistance: 1000 Megohms minimum at 500 VDC
Dielectric Strength: 2500 VAC for 1 minute

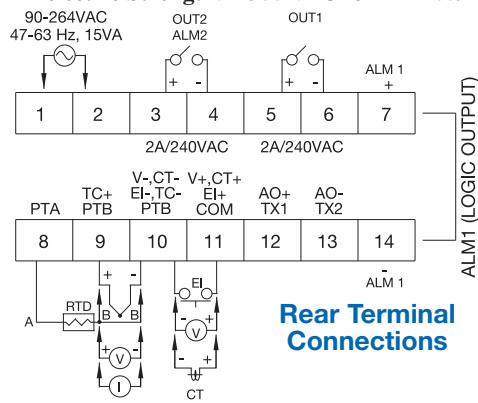

Rear Terminal Connections

Alarm 1 / Alarm 2

Alarm 1: 5 VDC logic output
Alarm 2 Relay: Form A, (NO) **Maximum rating:** 240 VAC, 2 Amp
Alarm Functions:
 Dwell timer PV1-PV2 High / Low Alarm
 Deviation Band High / Low Alarm Loop Break Alarm
 PV2 High / Low Alarm Sensor Break Alarm
Alarm Mode: Normal, Latching, Hold, Latching / Hold
Dwell Timer: 0 - 6553.5 minutes

Data Communications

Interface: RS-232 (1 unit), RS-485 (up to 247 units)
Protocol: Modbus Protocol – RTU mode

User Interface

Single 4-digit LED Displays: 0.4" / 10 mm Keypad: 3 keys
Programming Port: For automatic setup, calibration and testing

Control Mode

Output 1: Reverse (heating) or direct (cooling) action
Output 2: PID cooling control, cooling P band 1-255% of PB
On-Off: 0.1 - 100.0°F hysteresis control (P band = 0)
P or PD: 0 - 100.0% offset adjustment
PID: Fuzzy logic modified
Proportional band: 0.1 - 900°F (500°C)
Integral: 0 - 1000 seconds **Derivative:** 0 - 360 seconds

Cycle Time: 0.1 - 100 seconds

Manual Control: Heat (MV1) and Cool (MV2)

Auto-tuning: Cold start and warm start

Failure Mode: Auto-transfer to manual mode with sensor break or A-D converter damage

Ramping Control: 0 - 900°F/min or 0 - 900°F/hr ramp rate

Power Limit: 0 - 100% for output 1 and output 2

Remote Setpoint: Programmable range for voltage or current input

Digital Filter: Time constant: settable from 0.2 to 60 seconds

Analog Retransmission

Analog Retransmission Functions: PV1, PV2, PV1-PV2, PV2-PV1, setpoint, MV1, MV2, PV-SV deviation value

Output Signal: 4-20 / 0-20 mA, 0-1, 0-5, 1-5, 0-10 VDC

Accuracy: $\pm 0.05\%$ of span, $\pm 0.0025\%$ /°C

Environmental and Physical

Operating Temperature: 14 to 122°F (-10 to 50°C)

Storage Temperature: -40 to 140°F (-40 to 60°C)

Humidity: 0 to 90% RH, non-condensing

Dielectric Strength: 2000 VAC, 50/60 Hz for 1 minute

Dimensions: 1-3/64 x 2 x 4-3/8" (26.5 x 50 x 110.5 mm) HxWxD
 Depth behind panel: 3-7/8" (98 mm)

Panel Cutout: 7/8 x 1-25/32" (22 x 45 mm) HxW

Weight: 0.26 lb. (120 grams)

Approval Standards

Safety Standard: UL 3121-1,
 EN61010-1 (IEC1010-1)

EMC: EN61325

Protective Class: Front Panel: NEMA 4X / IP65
 Housing and Terminals: IP 20

Stock and Common Part Numbers
(Power Input: 90-264 VAC, w/ alarm 1, no data com)

Part Number	Signal Input	Out 1	Out 2 / Alarm 2	°F/°C
TEC02001	tc	relay	none	°F
TEC02002	tc	relay	relay	°F
TEC02003	tc	4-20 mA	none	°F
TEC02004	tc	4-20 mA	relay	°F
TEC02005	tc	DC pulse	none	°F
TEC02006	tc	relay	none	°C
TEC02007	tc	4-20 mA	none	°C
TEC02008	tc	DC pulse	none	°C