

Power Input

Standard: (TEC-410) 90-250 VAC, 47-63 Hz, 10 VA, 5W maximum
(TEC-910) 90-264 VAC, 47-63 Hz, 10 VA, 5W maximum

Optional: 11-26 VAC / VDC, 10 VA, 5W maximum

Signal Input

Resolution: 18 bits **Sampling Rate:** 5 samples / second

Accuracy: $\pm 0.24\%$ of span typical

Maximum Rating: -2 VDC minimum, 12 VDC maximum (1 minute for mA input)

Temperature Effect: $\pm 1.5 \mu\text{V} / ^\circ\text{C}$ for all inputs except mA input
 $\pm 3.0 \mu\text{V} / ^\circ\text{C}$ for mA input

Sensor Lead Resistance Effect: T/C: $0.2 \mu\text{V}/\text{ohm}$

Burn-out Current: 200nA

Common Mode Rejection Ratio (CMRR): 120 dB

Normal Mode Rejection Ratio (NMRR): 55 dB

Sensor Break Detection: Sensor open for TC inputs

Sensor Break Response Time: Within 4 seconds for TC and mV inputs; 0.1 second for 4-20 mA and 1-5 V inputs

Output 1 / Output 2

Relay Rating: 240 VAC, 2 Amp

Solid State Relay (Triac) Output

Rating: 1A / 240 VAC **Inrush Current:** 20A for 1 cycle

Min. Load Current: 50 mA rms

Max. Off-state Leakage: 3 mA rms

Max. On-state Voltage: 1.5 VAC rms

Insulation Resistance: 1000 Megohms minimum at 500 VDC

Dielectric Strength: 2500 VAC for 1 minute

VDC Voltage Supply (Output 2 only)

20 VDC, $\pm 0.5\text{V}$, at 25 mA

12 VDC, $\pm 0.3\text{V}$, at 40 mA

5 VDC, $\pm 0.15\text{V}$, at 80 mA

Event Input (standard TEC-410, optional TEC-910)

Resolution: 18 bits

Logic Low: -10 VDC minimum, 0.8 VDC maximum

Logic High: 2 VDC minimum, 10 VDC maximum

Functions: Remote reset, remote lockout

Limit Control

Modes available: High Limit, Low Limit and High/Low Limit

Data Communications

Interface: RS-485 (up to 247 units), RS-232, *TEC-410 only*

Protocol: Modbus Protocol – RTU mode

Address: 1-247

Baud Rate: 0.3 - 38.4 Kbits/sec

Data Bits: 8 bits

Parity Bit: None, Even or Odd

Stop Bit: 1 or 2 bits

Communication Buffer: 50 bytes

User Interface

Single 4-digit LED Displays: 0.4" / 10 mm

Keypad: 4 keys

Programming Port: For automatic setup, calibration and testing

Environmental and Physical

Operating Temperature: 14 to 122°F (-10 to 50°C)

Humidity: 0 to 90% RH, non-condensing

Dielectric Strength: 2000 VAC, 50/60 Hz for 1 minute

Dimensions:

TEC-410: 3-3/4 × 3-3/4 × 2-9/16" (96 × 96 × 65 mm) H×W×D

Depth behind panel: 2" (53 mm)

Panel Cutout: 3-21/32" × 3-21/32" (93 × 93 mm) H×W

Weight: 0.55 lb. (250 grams)

TEC-910: 1-7/8 × 1-7/8 × 3-3/4" (48 × 48 × 94 mm) H×W×D

Depth behind panel: 3-3/8" (86 mm)

Panel Cutout: 1-25/32" × 1-25/32" (45 × 45 mm) H×W

Weight: 0.33 lb. (150 grams)

Approval Standards

Safety: FM Class 3545 (OCT. 1998)

EN61010-1 (IEC1010-1)

TEC-410: UL61010C-1

TEC-910: UL873

Protective Class: IP30 front panel, indoor use,
IP20 housing and terminals (with protective cover)

EMC: EN61326

TEC-410 Stock and Common Part Numbers (Power Input: 90-250 VAC)

Part Number	Signal Input	Out 1	Out 2
TEC51001	tc	relay	none
TEC51002	tc	relay	relay
TEC51005	tc	SSR-1A	none
TEC51006	tc	SSR-1A	relay

TEC-910 Stock and Common Part Numbers (Power Input: 90-264 VAC)

Part Number	Signal Input	Out 1	Prog. I/O
TEC16001	tc	relay	event input
TEC16003	tc	SSR-1A	event input
TEC16004	tc	relay	none
TEC16006	tc	SSR-1A	none

NOTE: See page 13-46 for features common to TEC digital microprocessor-based temperature controls and the complete Table of Input Range and Accuracy.

(800) 323-6859 • Email: sales@tempco.com

TEC-410 1/4 DIN Rear Terminal Connections

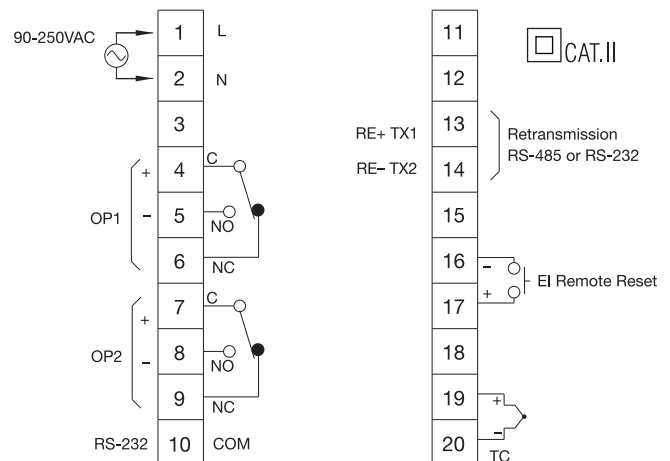

TEC-910 1/16 DIN Rear Terminal Connections

