

Ceramic Terminal Blocks & Connectors

Standard Ceramic Terminal Blocks for Internal Wiring

Used for wiring of heater power and thermocouple wiring in high temperature locations.

Design Features

- * **Maximum Voltage:** 600 VAC
- * **Maximum Current:** 20 Amp
- * **Maximum Temperature:** 450°C/842°F
- * **Wire Gauge:** 20 to 12 ga.
- * **Hardware:** Stainless Steel
- * **Terminals:** #8 Screw
- * **Body Material:** Steatite

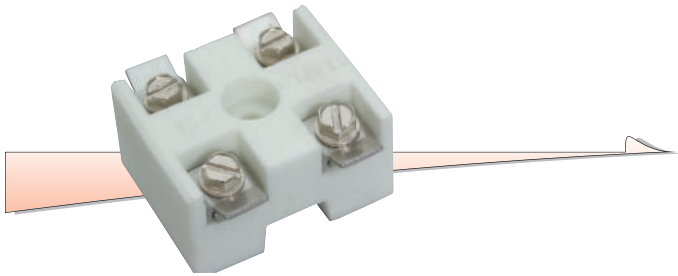

Part Number: EHD-108-101

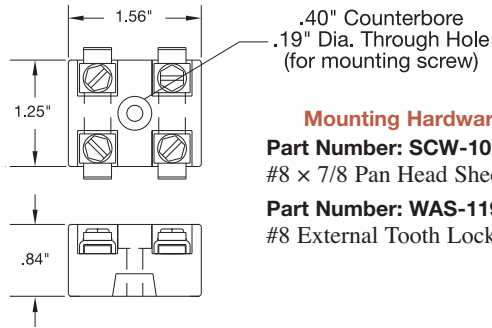

Mounting Hardware Supplied

Part Number: SCW-102-109

#8 x 7/8 Pan Head Sheet Metal Screw

Part Number: WAS-119-106

#8 External Tooth Lockwasher

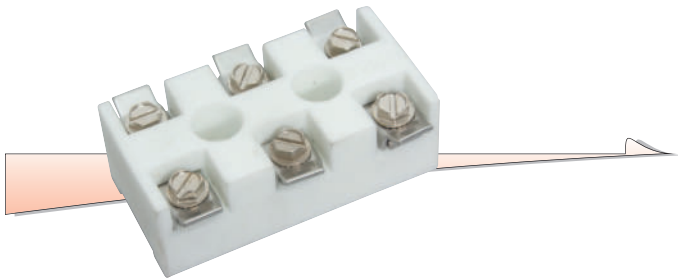

Part Number: EHD-108-121

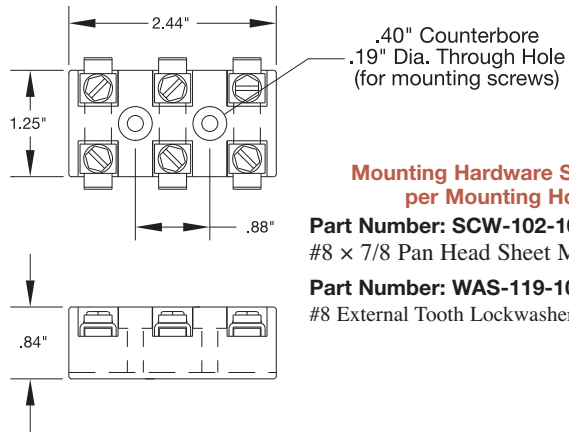

Mounting Hardware Supplied per Mounting Hole

Part Number: SCW-102-109

#8 x 7/8 Pan Head Sheet Metal Screws

Part Number: WAS-119-106

#8 External Tooth Lockwashers

Ceramic Wire Nut Connectors



Stock Number	MFR Part Number	Wire Range (Solid or Stranded Wire)		Skirt Length	Opening ID	Outer Diameter
EHD-114-102	10-401	2#22	1#18 + 1#16	.687"	.250"	.406"
EHD-114-103	10-405	2#20	2#16	.750"	.312"	.484"
EHD-114-104	10-407	2#18	2#14	.843"	.406"	.531"
EHD-114-105	-	1#16 + 1#14	1#14 + 2#12	1.00"	.468"	.703"

SPECIFICATIONS

Material: Porcelain

Maximum Temperature Rating: 1200°F (645°C)

Maximum Voltage: 300V

Agency Approvals: UL and CSA for EHD-114-102, EHD-114-103 and EHD-114-104 (UL File E9809)

All Items Available from Stock

View Product Inventory @ www.tempco.com

Ceramic Terminal Blocks

Ceramic Terminal Blocks (Enclosed Terminals)

Used for wiring of heater power and thermocouple wiring in high temperature locations.

Design Features

- * **Maximum Voltage:** 380 VAC
- * **Maximum Current:** 30 Amp
- * **Maximum Temperature:** 240°C/464°F
- * **Wire Gauge:** 26 to 12 ga. stranded, 26-14 solid
- * **Screw:** M3, zinc plated steel
- * **Terminal Body:** Nickel plated brass
- * **Body Material:** Porcelain
- * **Agency Approvals:** CE & VDE



Part Number: EHD-108-116

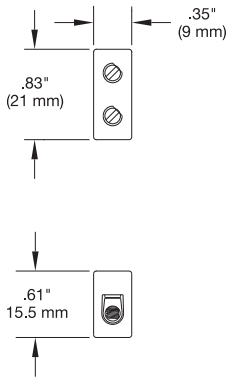

Part Number: EHD-108-117

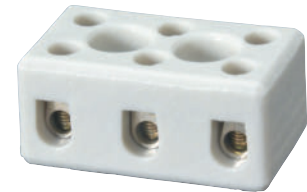
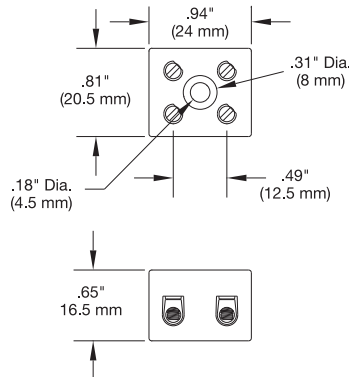

Part Number: EHD-108-118

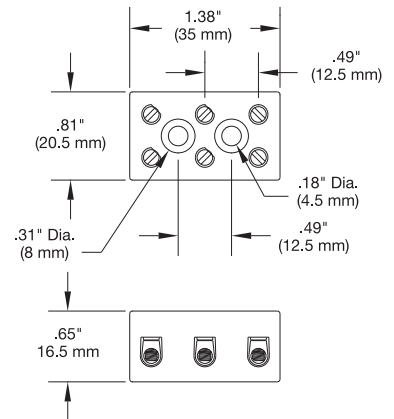

Ceramic Heavy Duty Terminal Blocks (Enclosed Terminals)

Used for wiring of heater power and thermocouple wiring in high temperature locations.

Design Features

- * **Maximum Voltage:** 600 VAC
- * **Maximum Current:** 50 Amp
- * **Maximum Temperature:** 200°C/392°F
- * **Wire Gauge:** 14 to 8 ga.
- * **Screw:** M4, zinc plated steel
- * **Terminal Body:** Nickel plated brass
- * **Body Material:** Porcelain
- * **Agency Approval:** UL, File # E69841

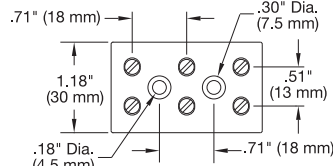
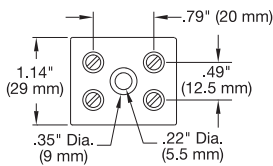

Stock Number: EHD-108-114

Stock Number: EHD-108-115

MFR Part Number: 4010-B

MFR Part Number: 4011-B

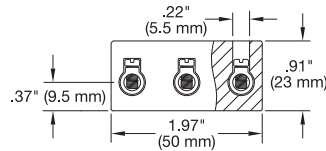
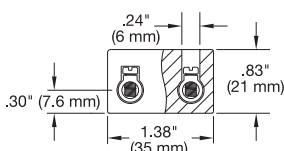

All Items Available from Stock



Ceramic Terminal Blocks

Heavy Duty High Temperature Ceramic Line Wiring Blocks (Exposed Terminals)

Used for interfacing heater assemblies, CRA housings and ARA arrays to external line wiring.

Design Features

- * **Maximum Voltage:** 500 VAC
- * **Maximum Current:** 44 Amp @ 104°F ambient
- * **Maximum Temperature:** 240°C/464°F
- * **Wire Gauge:** 18 to 8 ga.
- * **Terminal Screw:** M4, zinc-plated steel
- * **Body Material:** Steatite
- * **Agency Approvals:** None

Optional Terminal Hardware

Stainless Steel Flat Washer — Part Number: WAS-109-101

Spring Lock Washers — Part Number: WAS-118-108

Part Number: EHD-108-106

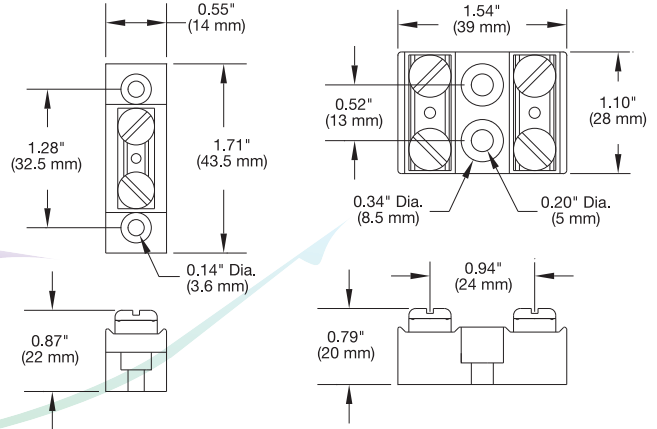

Part Number: EHD-108-107



Part Number: EHD-108-108

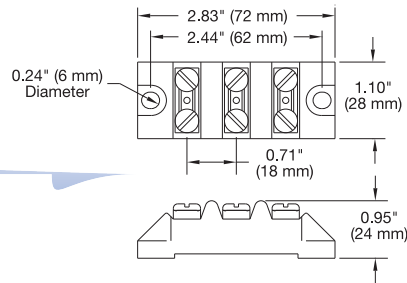

Part Number: EHD-108-109

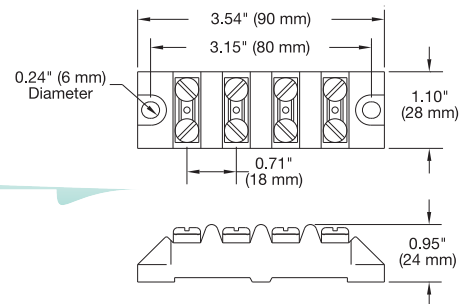

Part Number: EHD-108-105

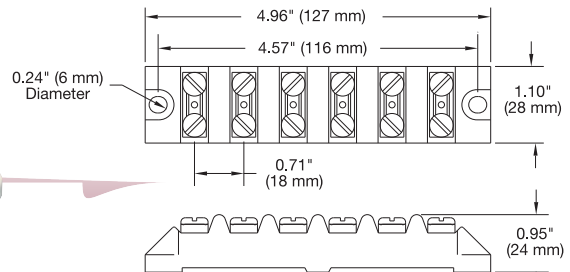

All Items Available from Stock

Stock Ceramic Accessories

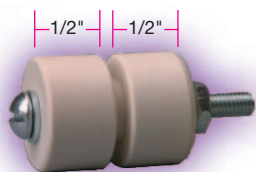

Secondary Insulating Bushings

Used to mount finned strip heaters in air heating applications. Also can be used when it is necessary to electrically isolate the heater from ground.

When Insulating Bushings are required, a 1/2" x 5/8" slot is substituted for the standard slot size (5/16" x 1/2").

Insulating Bushing Assembly

Part Number: CERR-1001

NOTE: Two assemblies are required for each heater.



When using secondary insulating bushings, the heater must be guarded to avoid any accidental contact. The guard must be electrically isolated from the heater and must be properly grounded.

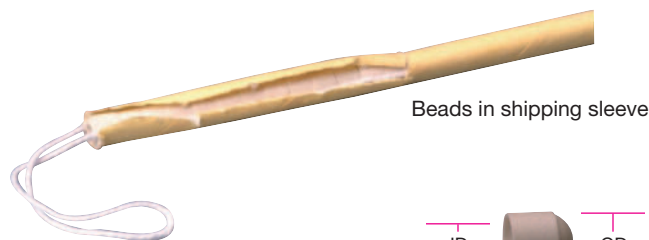
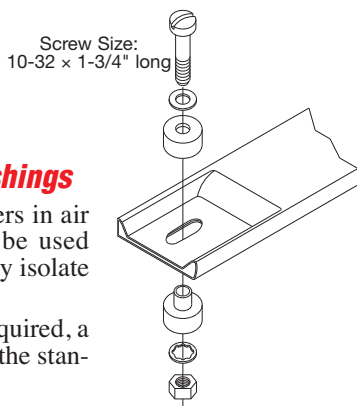

Ceramic Beads

Used to insulate bare lead wire at extremely high temperatures.

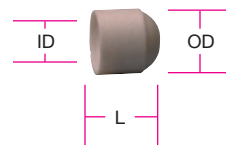

O.D. (in)	I.D. (in)	Length	Packaging	Sold By	Part Number
.110	.056	.110	67 beads/6" sleeve	Sleeve	CER-103-101
.170	.068	.170	86 beads/12" sleeve	Sleeve	CER-103-102
.200	.092	.200	36 beads/6" sleeve	Sleeve	CER-103-103
.200	.092	.200	bulk—loose	Piece	CER-103-104
.330	.124	.330	bulk—loose	Piece	CER-103-105
.203	.085	.203	bulk—loose	Piece	CER-103-108

Ceramic Covers for Insulating Screw Terminals

Used on the following heaters:

Mica Band • Ceramic Band • Mi-Plus® • Channel Strip • Finned Strip • Mica Strip

Provides an electrically safe environment on standard screw terminals.

Can be field retrofit or factory installed.

Igloo™ Ceramic Caps

Thread	Part Number
10-32	CER-102-101
10-24	CER-102-104
8-32	CER-102-105

Caps fit all Igloo™ bases below.

Ceramic Cap

Thread	Part Number
10-32	CER-102-101
10-24	CER-102-104
8-32	CER-102-105

All three caps fit conventional base.

Conventional Ceramic Base

Use with insulated terminals only.

Part Number: CER-101-101



Igloo™ Ceramic Bases

Type	Part Number
Double Port In-Line	CER-101-104
Double Port 90°	CER-101-106
Single Port	CER-101-107

Ceramic Cap CER-102-103 and Base CER-101-103 below are primarily used on cast-in .430 diameter tubular heating elements



Description

Ceramic Cap w/10-32 thread
Ceramic Base – .430 diameter

Part Number

CER-102-103
CER-101-103

All Items Available from Stock