

Mi-Plus® Built-In Clamping Strap Variations

Mi-Plus Low Profile Built-In Clamping Strap

When space is limited use Tempco's low profile clamping, a design that doesn't sacrifice strength for size. This compact design uses 10-32 alloy socket head cap screws.

Standard on all Mi-Plus heaters less than 3" in diameter

Limitations **Minimum Width:** 1-1/2" (38.1 mm)
Minimum Diameter: 1-3/8" (34.9 mm)

Type LB — One-Piece Band

Type LS — Two-Piece Band

Type LE — One-Piece Expandable Band

Consult Tempco for multiple segment heaters.

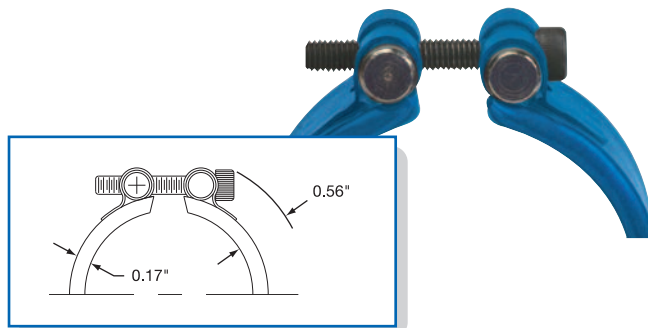

Mi-Plus Outrigger Built-In Clamping Strap

This design is unique to 1" wide heaters from 1-3/8" diameter and greater. Two 8-32 alloy socket head cap screws are used to give 1" wide heaters the required clamping power.

Standard on Mi-Plus heaters 1" wide and 1-3/8" in diameter and greater.

Type OB — One-Piece Band

Type OS — Two-Piece Band

Consult Tempco for multiple segment heaters.

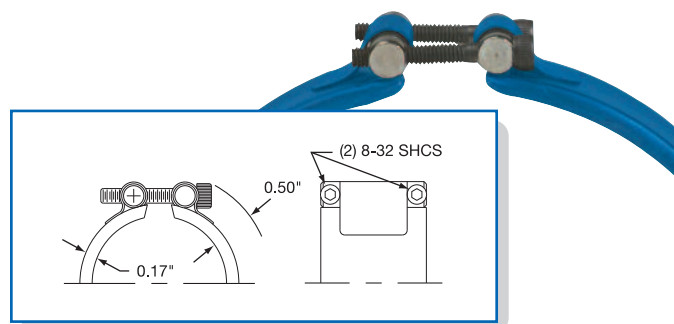

Mi-Plus Spring Loaded Built-In Clamping Strap

Spring loaded clamping with alloy steel socket head cap screws is standard on heaters over 8" in diameter and offered as an option on any heater with standard brackets. The extra heavy duty compression springs serve to combat thermal expansion of the heater by self adjustment, thereby ensuring excellent contact of the heater surface with the machine barrel or die. This type of clamping is also useful on heaters that are mounted vertically.

Limitations

Minimum Width: 1-1/2" (38.1 mm)

Minimum Diameter: 3-1/2" (88.9 mm)

Type SL — One-Piece Band

Type NSL — Two-Piece Band

Type NEL — One-Piece Expandable Band

Consult Tempco for multiple segment heaters.

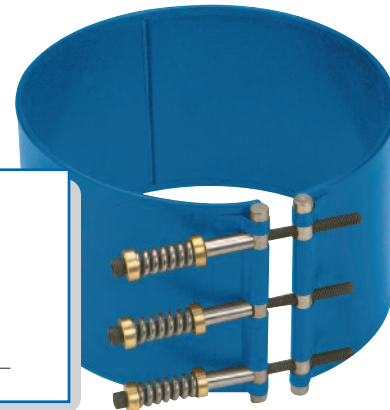
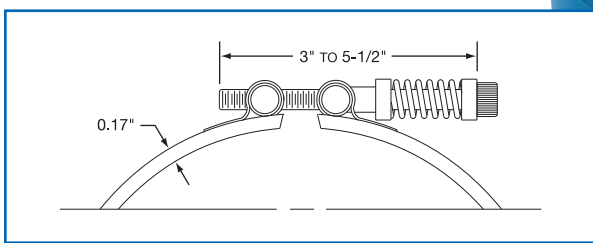

Mi-Plus Weld-On Bracket

The Mi-Plus is available without built-in brackets. For this option, brackets are welded onto the heater plate at user-specified locations. A weld-on bracket is useful when clearance is limited or there is an obstruction for using separate straps. Consult Tempco with your requirements.

Limitations **Minimum Width:** 1" (25.4 mm)

Minimum Diameter: 1" (25.4 mm)

Type WB — One-Piece Band

Type WS — Two-Piece Band

Type WE — One-Piece Expandable Band

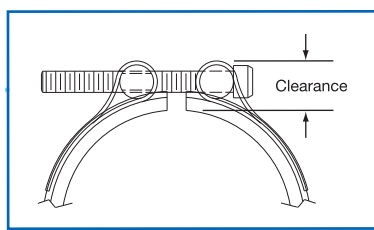

Bolt Size	Clearance
8-32	.50"
10-32	.56"
1/4-20	.62"



Note: The number of weld-on brackets is dependent on heater width. Tempco recommends the use of the largest bolt size that clearance allows.