

Standard Duct Heater Features

Design Features

- * NEMA 1 General Purpose Ventilated Enclosure
- * Painted Steel Mounting Flange
- * Single- and Three-Phase Wiring
- * 3-1/2" (89 mm) Insulation
- * Field Replaceable Incoloy® 840 Elements
- * Element Bends Re-pressed
- * 1/4" (6 mm) Inside Diameter Thermowell
- * Stainless Steel Support Plate and Corner Posts

Typical Installation

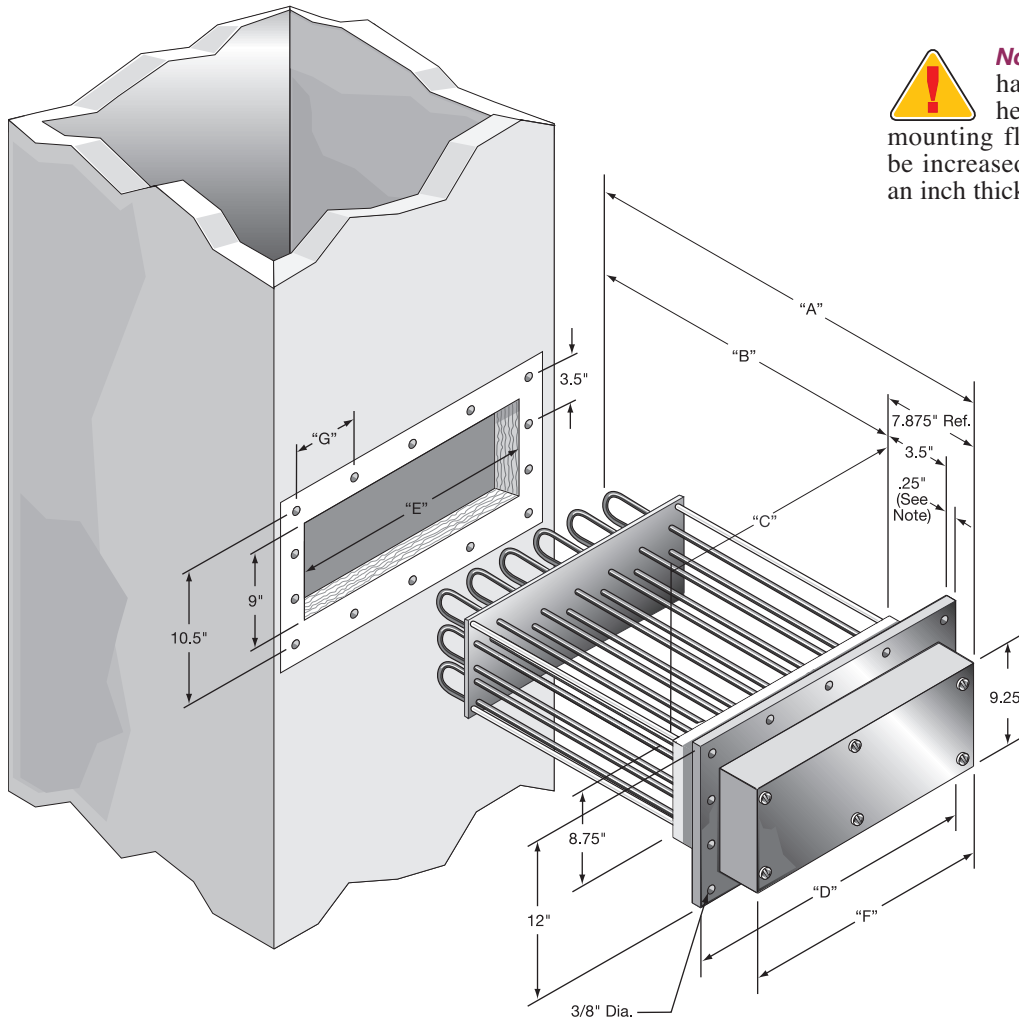

Standard (Non-Stock) Duct Heater Construction Specifications

Dimensions Reference Number	"A"		"B"		"C"		"D"		"E"		"F"		"G"		Number of Elements	Approximate Net Weight	
	in	mm	in	mm	in	mm	in	mm	in	mm	in	mm	in	mm		lbs	kgs
1	27 ⁷ / ₈	708	20	508	2 ³ / ₄	70	6 ¹ / ₂	165	3	76	3 ³ / ₈	92	2 ¹ / ₂	64	6	22	10
2	27 ⁷ / ₈	708	20	508	4 ³ / ₄	121	8 ¹ / ₂	216	5	127	5 ⁵ / ₈	143	3 ¹ / ₂	89	12	31	14
3	27 ⁷ / ₈	708	20	508	6 ³ / ₄	171	10 ¹ / ₂	267	7	178	7 ⁷ / ₈	194	3	76	18	41	19
4	27 ⁷ / ₈	708	20	508	8 ³ / ₄	222	12 ¹ / ₂	318	9	229	9 ⁵ / ₈	244	2 ³ / ₄	70	24	51	23
5	27 ⁷ / ₈	708	20	508	10 ³ / ₄	273	14 ¹ / ₂	368	11	279	11 ¹ / ₈	295	3 ¹ / ₄	83	30	62	28
6	27 ⁷ / ₈	708	20	508	12 ³ / ₄	324	16 ¹ / ₂	419	13	330	13 ³ / ₈	346	3 ³ / ₄	95	36	73	33
7	27 ⁷ / ₈	708	20	508	14 ³ / ₄	375	18 ¹ / ₂	470	15	381	15 ⁵ / ₈	397	4 ¹ / ₄	108	42	84	38
8	27 ⁷ / ₈	708	20	508	16 ³ / ₄	425	20 ¹ / ₂	521	17	432	17 ⁵ / ₈	448	4 ³ / ₄	121	48	95	43
9	27 ⁷ / ₈	708	20	508	18 ³ / ₄	476	22 ¹ / ₂	572	19	483	19 ⁵ / ₈	498	5 ¹ / ₄	133	54	106	48
10	27 ⁷ / ₈	708	20	508	20 ³ / ₄	527	24 ¹ / ₂	622	21	533	21 ³ / ₈	549	5 ³ / ₄	146	60	117	53
11	32 ⁷ / ₈	835	25	635	20 ³ / ₄	527	24 ¹ / ₂	622	21	533	21 ⁵ / ₈	549	5 ³ / ₄	146	60	130	59
12	40 ³ / ₈	1026	32 ¹ / ₂	826	20 ³ / ₄	527	24 ¹ / ₂	622	21	533	21 ⁵ / ₈	549	5 ³ / ₄	146	60	155	70
13	49 ⁷ / ₈	1254	41 ¹ / ₂	1054	20 ³ / ₄	527	24 ¹ / ₂	622	21	533	21 ⁵ / ₈	549	5 ³ / ₄	146	60	180	82