

Finned Duct Heaters

Design Features

- * NEMA 1 General Purpose Ventilated Enclosure
- * Stainless Steel Mounting Flange and Terminal Box
- * Single- and Three-Phase Wiring
- * 1" (25 mm) Insulation
- * Field Replaceable .430 Diameter Stainless Steel Elements
- * 9/32" (7 mm) ID Sensor Thermowell
- * Stainless Steel Support Plate and Corner Posts
- * Stainless Steel Insulation Housing

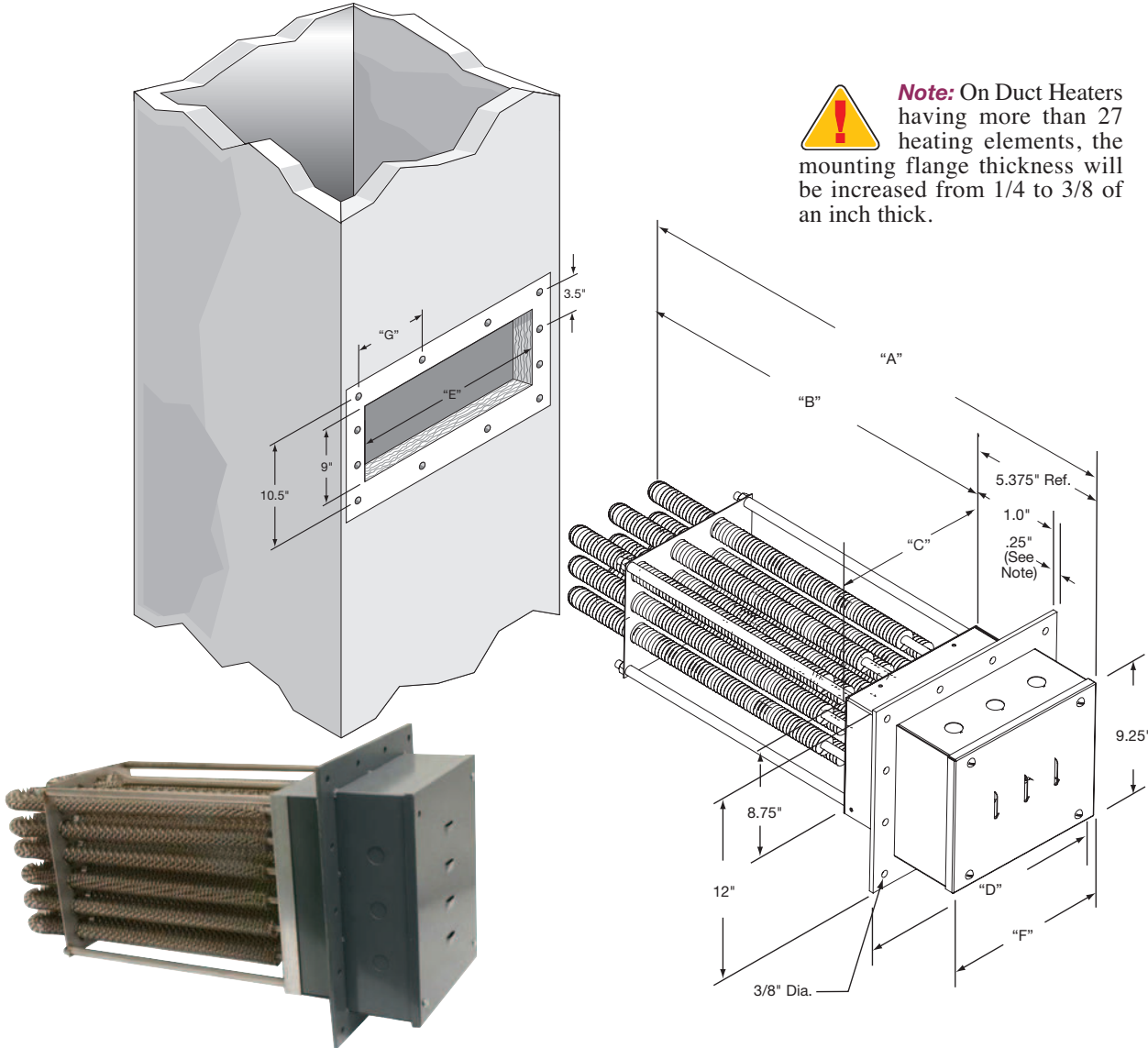

Standard (Non-Stock) Duct Heater Construction Specifications

Dimensions Reference Number	"A"		"B"		"C"		"D"		"E"		"F"		"G"		Number of Elements	Approximate Net Weight	
	in	mm	in	mm	in	mm	in	mm	in	mm	in	mm	in	mm		lbs	kgs
1	25 ³ / ₈	645	20	508	3 ¹ / ₄	95	7	177.8	4	102	4 ¹ / ₄	108	2 ³ / ₄	70	3	22	10
2	25 ³ / ₈	645	20	508	6 ¹ / ₄	159	9 ¹ / ₂	241	6.5	165	6 ³ / ₄	171	4	102	6	31	14
3	25 ³ / ₈	645	20	508	8 ³ / ₄	222	12	305	9	229	9 ¹ / ₄	235	3 ¹ / ₂	89	9	41	19
4	25 ³ / ₈	645	20	508	11 ³ / ₄	298	14 ¹ / ₂	368	12	305	11 ³ / ₄	298	3 ¹ / ₄	83	12	51	23
5	25 ³ / ₈	645	20	508	13 ³ / ₄	349	17	432	14	356	14 ¹ / ₄	362	3 ⁷ / ₈	98	15	62	28
6	25 ³ / ₈	645	20	508	16 ¹ / ₄	413	19 ¹ / ₂	495	16.5	419	16 ³ / ₄	425	4 ¹ / ₂	114	18	73	33
7	25 ³ / ₈	645	20	508	18 ³ / ₄	476	22	559	19	483	19 ¹ / ₄	489	4 ³ / ₈	105	21	84	38
8	25 ³ / ₈	645	20	508	21 ³ / ₄	552	24 ¹ / ₂	622	22	559	21 ³ / ₄	552	4 ⁵ / ₈	117	24	95	43
9	25 ³ / ₈	645	20	508	23 ³ / ₄	603	27	686	24	610	24 ¹ / ₄	616	5 ¹ / ₈	130	27	106	48
10	25 ³ / ₈	645	20	508	26 ¹ / ₄	679	29 ¹ / ₂	749	27	686	26 ³ / ₄	679	5 ³ / ₈	143	30	117	53
11	30 ¹ / ₄	768	24 ⁷ / ₈	632	26 ³ / ₄	679	29 ¹ / ₂	749	27	686	26 ³ / ₄	679	5 ³ / ₈	143	30	130	59
12	37 ¹ / ₄	946	31 ⁷ / ₈	810	26 ³ / ₄	679	29 ¹ / ₂	749	27	686	26 ³ / ₄	679	5 ³ / ₈	143	30	155	70
13	45	1143	39 ³ / ₈	1006	26 ³ / ₄	679	29 ¹ / ₂	749	27	686	26 ³ / ₄	679	5 ³ / ₈	143	30	180	82