

Temperature Control

Thermostats

Thermostats are an optional feature on flanged immersion heaters. This type of control operates by expansion and contraction of a liquid in response to temperature change. Liquid contained within the sensing bulb and capillary flexes a diaphragm, causing the opening and closing of a snap action switch. For heating applications the contacts are normally closed and open on temperature rise.

Installation Warnings and Recommendations



1. Do not use the thermostat as a power switch. Use some other means of disconnecting power to the heater for servicing.
2. A Thermostat is not a fail-safe device. Use an approved high temperature limit control and/or pressure limit control for safe operation.
3. Avoid kinking or bending the capillary tube too sharply as this will alter the calibration and/or render the thermostat inoperable.
4. Excess capillary tube should be coiled neatly in junction box.
5. The capillary tube must never touch the thermostat contacts as this will create an electrical short capable of harming personnel and/or equipment.

Thermocouples

Type J or Type K thermocouples can be supplied for process temperature or over-temperature control. Type J is reliable and accurate for temperatures up to 1000°F (538°C). Type K should be used for higher temperatures.

For measuring process temperatures the thermocouple can be mounted in a thermowell in the center of the element bundle. Note that a location somewhere away from the heater may give a more accurate measurement of process temperature.

For over-temperature protection the thermocouple is usually attached to one of the elements (Figure A) and any unusual rise in element temperature would shut the heater down. This thermocouple may also be mounted in a thermowell (Figure B), which is then attached to one of the heating elements if desired. This protects the thermocouple from the solution being heated and allows you to replace it without removing the heater, but does increase its response time.

Temperature and over-temperature controls for using the signal generated by thermocouples and how to select the best control for your application can be found in Section 13.

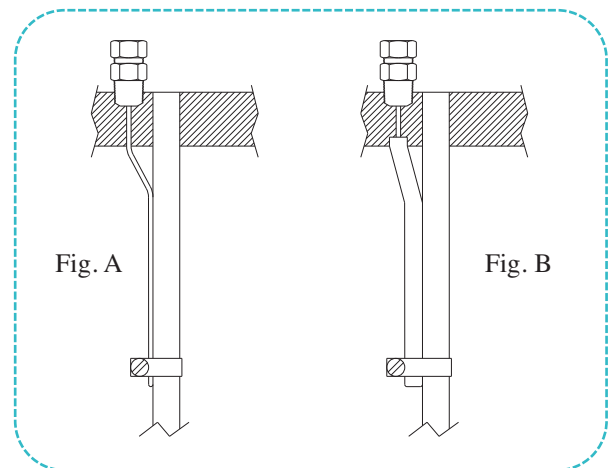

Series CHX-100, CHX-200 and CHX-300 Circulation Heaters — See Pages 3-12 through 3-17

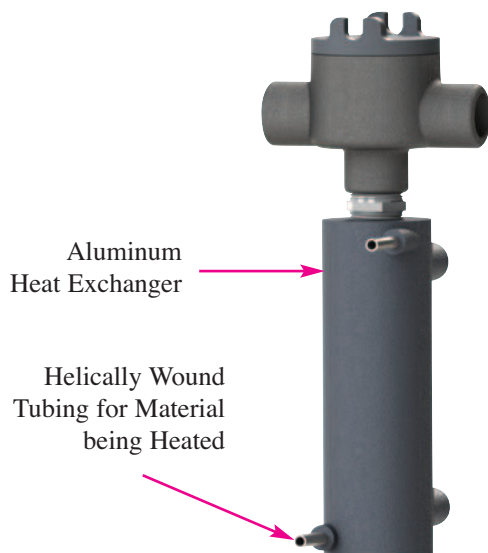

Construction

Series CHX circulation heaters are compact lightweight units used for heating gases or liquids. The material being heated is pumped through the coiled seamless 316 SS tubing which has been cast into an aluminum body which acts as the heat exchanger. A replaceable Hi-Density cartridge set into a hole bored into the aluminum is the heat source for the CHX-100, and a tubular heating element is the heat source for the CHX-200 and CHX-300. The material being heated never comes into contact with the heating element.