

General Purpose Tank or Reservoir Water Immersion Heater

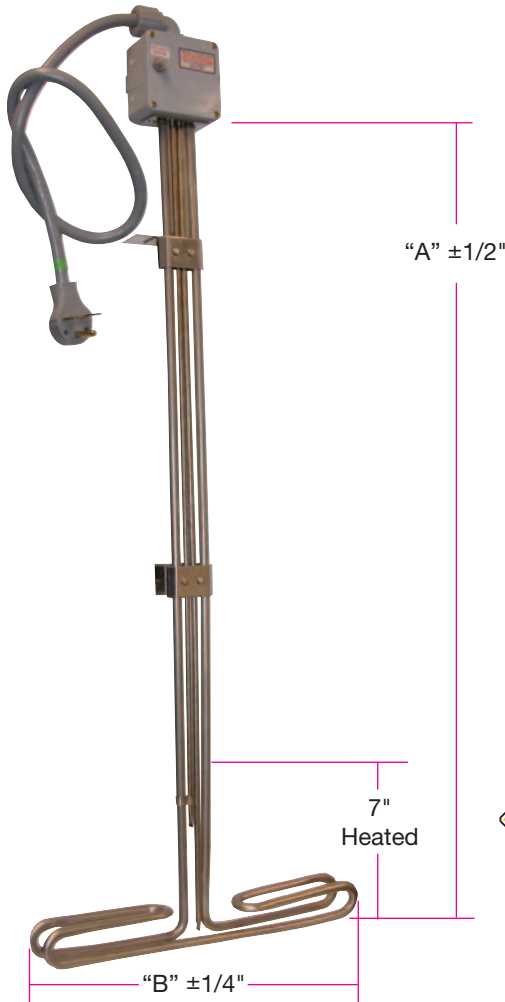

Design Features

- * Immersion section of heater made of 316 Stainless Steel
- * Cold riser extends to the top of container where control housing is located
- * Cord set with 3-wire grounding plug is included for easy installation and wiring.
- * Adjustable vapor-proof thermostat control with temperature range of 55°F to 115°F (±3°)
- * Hi-limit cut switch set to 125°F (±4°)
- * Stainless Steel mounting bracket also supplied for easy mounting
- * Pilot light and on-off switch provided

Hi-Limit:

If the thermostat should fail and its contacts stick in a closed position, the heating element will continue to heat to about 125°F. At this temperature the Hi-Limit will open and turn the heating element off. After repairing or replacing the thermostat the Hi-Limit can be manually reset.



Hazard of electric shock. Installation must be grounded to earth and heater connected to line input through properly sized GFCI circuit breaker.

Disconnect power to heater before servicing. There should be no body contact with the water while the heater is in the water.

Under NO circumstances should this heater be turned on unless the system is full of water.

Standard (Non-Stock) and Stock Sizes and Electrical Ratings

Stock Items Are Shown In RED

Sheath	Watt Density w/in ²	Watts	Volts	"A" Dim. in	"B" Dim. in	Part Number	
						4 ft. cord	6 ft. cord
316 Stainless Steel (Bright Annealed)	51	6000	240	39-3/4	17-1/2	TAT40012	TAT40017
	13	1440	120	39-3/4	17-1/2	TAT40016	TAT40013

Wiring Diagram – Internal Electrical Connections

