

Deep Tank/Sump Immersion Heaters

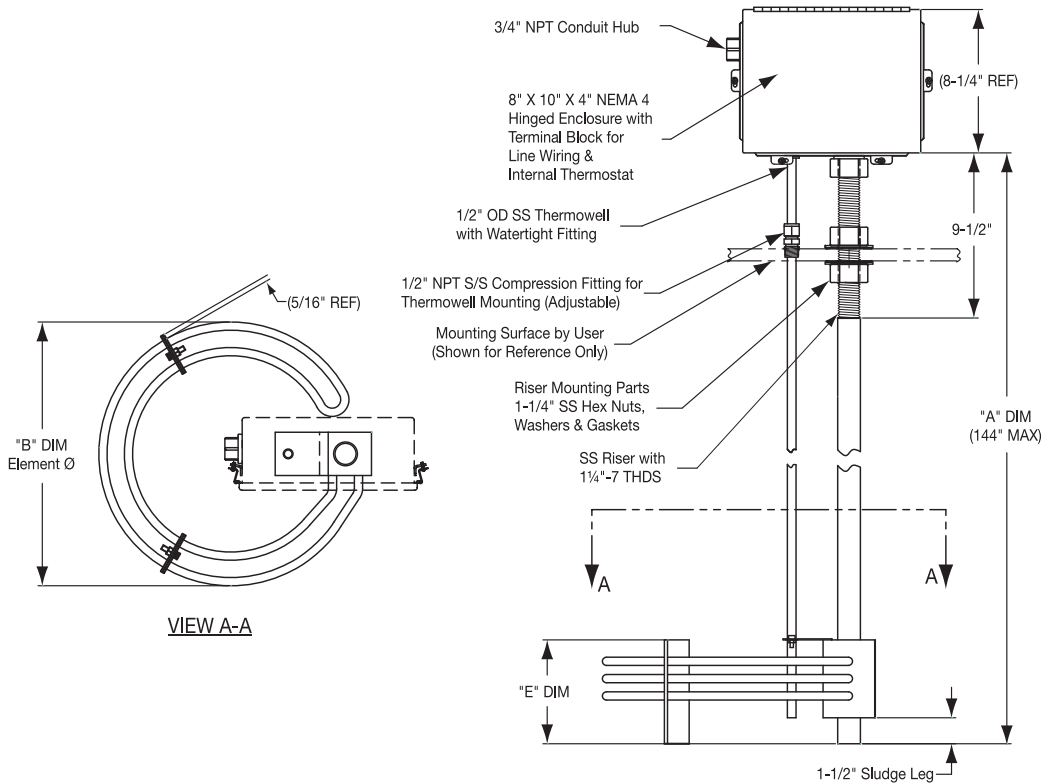

Standard (Non-Stock) Deep Tank & Sump Immersion Heaters – 12 watts/sq. in.

KW	Number of Elements	"A" Dim. in	"B" Dim. in	"E" Dim. in	Part Number			
					240V-1Ph	240V-3Ph	480V-1Ph	480V-3Ph
4	3	72	15-1/4	7-1/2	TAT60001	TAT60002	TAT60003	TAT60004
8	6	72	15-1/4	10-1/2	TAT60005	TAT60006	TAT60007	TAT60008
12	9	72	15-1/4	13-1/2	TAT60009	TAT60010	TAT60011	TAT60012
15	12	72	15-1/4	16-1/2	—	TAT60013	TAT60014	TAT60015
20	15	72	15-1/4	19-1/2	—	TAT60016	TAT60017	TAT60018
30	24	72	15-1/4	28-1/2	—	—	TAT60019	TAT60020

Ordering Information

Custom Engineered/Manufactured Heaters

An electric heater can be very application specific; for sizes and ratings not listed, **TEMPCO** will design and manufacture an Over-the-Side Immersion Heater to meet your requirements.

Standard lead time is 4 weeks.

Please Specify the following:

- Application
- Wattage, Voltage and Phase
- Element Sheath Material
- Number of Elements
- Element Watt Density
- "A" and "B" dimensions
- Optional Features
- Quantity

Catalog Heaters
Order-by Part Numbers.

⚠ WARNING: Cancer and Reproductive Harm - www.P65Warnings.ca.gov.