

Fluoropolymer (PTFE) Single-Element L-Shaped Round Heater

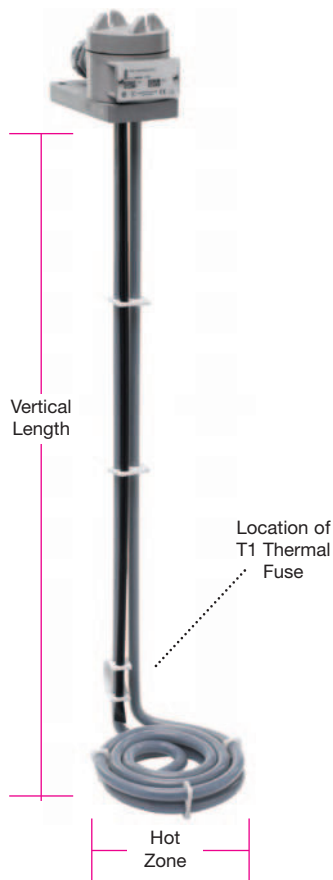

Typical Applications

Compatible with most plating tank solutions; inert to acids, anodizing and pickling solutions up to 190°F (88°C). Check compatibility guide on pages 11-88 and 11-89 and with chemical supplier for proper sheath material selection.

Replaces more expensive alumina or graphite heaters.

Design Features

- * Low profile bottom design for even heating and varying liquid levels
- * 10 watts/in² (1.6 watts/cm²) for long service life
- * Non-contaminating Fluoropolymer (PTFE) covered stainless steel elements
- * T1 thermal fuse protection standard; T2 bi-metal switch optional
- * Grounded internal metal element for safety
- * UL listed for US and Canada
- * Lightweight, non-floating construction
- * Vapor-tight polypropylene terminal enclosure with universal mounting flange
- * Standard 3-ft. flexible PVC liquid-tight conduit
- * Single-Phase only
- * 120, 240, 480 volts standard as listed — other voltages available
- * Longer and shorter vertical lengths available; consult Tempco

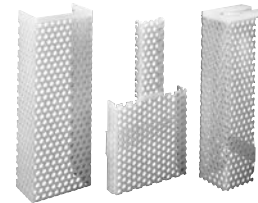
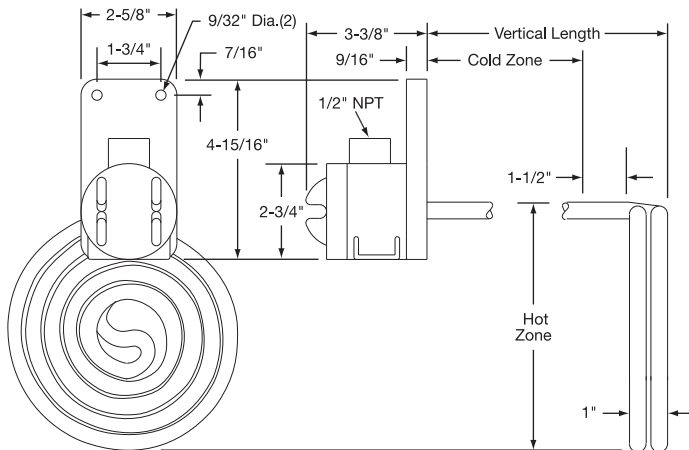

Note: Guards are recommended for all fluoropolymer heaters. Standard guards are made of polypropylene. Fluoropolymer (PTFE) guards are available for chromic acid and temperatures above 180°F (82°C).

Standard (Non-Stock) Sizes and Ratings with Polypropylene Guard

Watts	Part Number			Hot Zone		Vertical Length		Diameter	
	120V	240V	480V	in	mm	in	mm	in	mm
500	TMT04001	TMT04002	—	5	127	12	305	5	127
1000	TMT04003	TMT04004	—	6	152	12	305	6	152
2000	TMT04005	TMT04006	TMT04007	8	203	18	457	8	203
3000	—	TMT04008	TMT04009	9	229	18	457	9	229
4000	—	TMT04010	TMT04011	11	279	18	457	11	279
5000	—	TMT04012	TMT04013	12	305	18	457	12	305
6000	—	TMT04014	TMT04015	13	330	18	457	13	330

Standard lead time is 2 to 3 weeks.

Ordering Information

See page 11-90