



Power Input

Standard: 90-264 VAC, 47-63 Hz, 15 VA, 7W maximum
Optional: 11-26 VAC / VDC, 15 VA, 7W maximum

Signal Input

Input 1

Resolution: 18 bits **Sampling Rate:** 5 samples / second
Accuracy: ±.24% of span typical
Maximum Rating: -2 VDC minimum, 12 VDC maximum (1 minute for mA input)

Temperature Effect: ±1.5 μV / °C for all inputs except mA input
 ±3.0 μV / °C for mA input

Sensor Lead Resistance Effect: T/C: 0.2μV/ohm
 3-wire RTD: 2.6°C/ohm of resistance difference of two leads

Burn-out Current: 200nA

Common Mode Rejection Ratio (CMRR): 120 dB

Normal Mode Rejection Ratio (NMRR): 55 dB

Sensor Break Detection: Sensor open for TC, RTD and mV inputs; sensor short for RTD input; below 1 mA for 4-20 mA input; below 0.25V for 1-5V input; unavailable for other inputs

Sensor Break Response Time: Within 4 seconds for TC, RTD and mV inputs; 0.1 second for 4-20 mA and 1-5 V inputs

Input 2

Resolution: 18 bits **Sampling Rate:** 1.66 times per second

Sensor Break Response Time: 0.5 second

Types: **Current Transducer:** 0 to 50 Amp
 mA: -3 to 27 mA V: -1.3 to 11.5 VDC

Input 3

Event Input Functions: Select 2nd setpoint and/or PID, disable output 1 and/or output 2, remote lockout reset alarm 1 and/or alarm 2

Logic Low: -10V min., 0.8V max.

Logic High: 2V min., 10V max.

External Pull-Down Resistance: 400KΩ max

External Pull-Up Resistance: 1.5MΩ min

Output 1 or Output 2 / Alarm 2

Relay Rating: 240 VAC, 2 Amp

Pulsed Voltage: Source voltage 5V, Current limiting resistance 66Ω

Linear Output — Characteristics

Type	Tolerance	Zero Tolerance	Span Capacity	Load
4-20 mA		3.6-4.0 mA	20-21 mA	500Ω max
0-20 mA		0 mA	20-21 mA	500Ω max
0-5 VDC		0 VDC	5-5.25 VDC	10 KΩ min
1-5 VDC		0.9-1.0 VDC	5-5.25 VDC	10 KΩ min
0-10 VDC		0 VDC	10-10.5 VDC	10 KΩ min

Resolution: 15 bit analog to digital converter

Isolation Breakdown Voltage: 1000 VAC

Solid State Relay (Triac) Output

Rating: 1A / 240 VAC **Inrush Current:** 20A for 1 cycle

Min. Load Current: 50 mA rms

Max. Off-state Leakage: 3 mA rms

Max. On-state Voltage: 1.5 VAC rms

Insulation Resistance: 1000 Megohms minimum at 500 VDC

Dielectric Strength: 2500 VAC for 1 minute

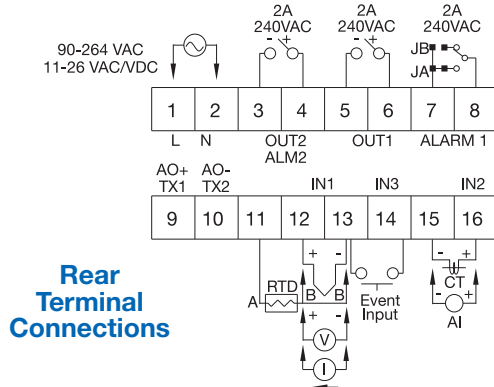

Rear Terminal Connections

Alarm 1 / Alarm 2

Alarm 1 Relay: Form A, (NO) Maximum rating: 240 VAC, 2 Amp

Alarm 1 Relay: Form A, (NC) Maximum rating: 240 VAC, 2 Amp

Alarm Functions:

Dwell timer PV1-PV2 High / Low Alarm
 Deviation Band High / Low Alarm Loop Break Alarm
 PV2 High / Low Alarm Sensor Break Alarm

Alarm Mode: Normal, Latching, Hold, Latching / Hold

Dwell Timer: 0 - 6553.5 minutes

Data Communications

Interface: RS-232 (1 unit), RS-485 (up to 247 units)

Protocol: Modbus Protocol – RTU mode

User Interface

Dual 4-digit LED Display: 0.40" (10 mm) Red Process Display

Keypad: 3 keys 0.31" (8 mm) Green Setpoint Display

Programming Port: For automatic setup, calibration and testing

Control Mode

Output 1: Reverse (heating) or direct (cooling) action

Output 2: PID cooling control, cooling P band 1-255% of PB

On-Off: 0.1 - 100.0°F hysteresis control (P band = 0)

P or PD: 0 - 100.0% offset adjustment

PID: Fuzzy logic modified

Proportional band: 0.1 - 900°F (500°C)

Integral: 0 - 1000 seconds **Derivative:** 0 - 360 seconds

Cycle Time: 0.1 - 100 seconds

Manual Control: Heat (MV1) and Cool (MV2)

Auto-tuning: Cold start and warm start

Failure Mode: Auto-transfer to manual mode with sensor break or A-D converter damage

Ramping Control: 0 - 900°F/min or 0 - 900°F/hr ramp rate

Power Limit: 0 - 100% for output 1 and output 2

Remote Setpoint: Programmable range for voltage or current input

Digital Filter: Time constant: settable from 0.2 to 60 seconds

Analog Retransmission

Analog Retransmission Functions: PV1, PV2, PV1-PV2, PV2-PV1, Setpoint, MV1, MV2, PV-SV deviation value

Output Signal: 4-20 / 0-20 mA, 0-1, 0-5, 1-5, 0-10 VDC

Accuracy: ±0.05 % of span, ±0.0025 %/°C

Environmental and Physical

Operating Temperature: 14 to 122°F (-10 to 50°C)

Storage Temperature: -40 to 140°F (-40 to 60°C)

Humidity: 0 to 90% RH, non-condensing

Dielectric Strength: 2000 VAC, 50/60 Hz for 1 minute

Dimensions: 2 × 2 × 3-1/2" (51 × 51 × 89 mm) H×W×D
 Depth behind panel: 3" (75 mm)

Panel Cutout: 1-25/32 × 1-25/32" (45 × 45 mm) H×W

Weight: 0.33 lb. (150 grams)

Approval Standards

Safety Standard: UL3121-1 and CSA: C22.2 No. 24-93
 EN61010-1 (IEC1010-1)

Protective Class: **Front panel:** NEMA 4X / IP65
Housing and Terminals: IP 20

EMC: EN61325

Stock and Common Part Numbers

(Power Input: 90-264 VAC, no data com)

Part Number	Signal Input	Out 1	Out 2 / Alarm 2	Alarm 1
TEC13001	tc-J	relay	none	none
TEC13002	tc-J	relay	relay	none
TEC13003	tc-J	4-20 mA	none	none
TEC13004	tc-J	4-20 mA	relay	none
TEC13005	tc-J	DC pulse	none	none
TEC13006	tc-J	DC pulse	relay	none