



Power Input

Standard: 90 - 264 VAC, 47-63 Hz, 15 VA, 7W maximum
Optional: 11 - 26 VAC / VDC, 15 VA, 7W maximum

Signal Input

Input 1

Resolution: 18 bits **Sampling Rate:** 5 samples / second
Accuracy: ±.24% of span typical
Maximum Rating: -2 VDC minimum, 12 VDC maximum (1 minute for mA input)

Temperature Effect: ±1.5 $\mu\text{V} / ^\circ\text{C}$ for all inputs except mA input
 ±3.0 $\mu\text{V} / ^\circ\text{C}$ for mA input

Sensor Lead Resistance Effect: T/C: 0.2 $\mu\text{V}/\text{ohm}$
 3-wire RTD: 2.6 $^\circ\text{C}/\text{ohm}$ of resistance difference of two leads

Burn-out Current: 200nA

Common Mode Rejection Ratio (CMRR): 120 dB

Normal Mode Rejection Ratio (NMRR): 55 dB

Sensor Break Detection: Sensor open for TC, RTD and mV inputs; sensor short for RTD input; below 1 mA for 4-20 mA input; below 0.25V for 1-5V input; unavailable for other inputs

Sensor Break Response Time: Within 4 seconds for TC, RTD and mV inputs; 0.1 second for 4-20 mA and 1-5 V inputs

Input 2

Resolution: 18 bits **Sampling Rate:** 1.66 times per second

Sensor Break Response Time: 0.5 second

Types: **Current Transducer:** 0 to 50 Amp
 mA: -3 to 27 mA **V:** -1.3 to 11.5 VDC

Input 3

Event Input Functions: Select 2nd setpoint, and/or PID, disable output 1 and/or output 2, remote lockout

Output 1 or Output 2

Relay Rating: 240 VAC, 2 Amp

Pulsed Voltage: Source voltage 5V, Current limiting resistance 66 Ω

Linear Output — Characteristics

Type	Tolerance	Zero Tolerance	Span Capacity	Load
4-20 mA		3.6-4.0 mA	20-21 mA	500 Ω max
0-20 mA		0 mA	20-21 mA	500 Ω max
0-5 VDC		0 VDC	5-5.25 VDC	10 K Ω min
1-5 VDC		0.9-1.0 VDC	5-5.25 VDC	10 K Ω min
0-10 VDC		0 VDC	10-10.5 VDC	10 K Ω min

Resolution: 15 bit analog to digital converter

Isolation Breakdown Voltage: 1000 VAC

Solid State Relay (Triac) Output

Rating: 1A / 240 VAC **Inrush Current:** 20A for 1 cycle

Min. Load Current: 50 mA rms

Max. Off-state Leakage: 3 mA rms

Max. On-state Voltage: 1.5 VAC rms

Insulation Resistance: 1000 Megohms minimum at 500 VDC

Dielectric Strength: 2500 VAC for 1 minute

Rear Terminal Connections

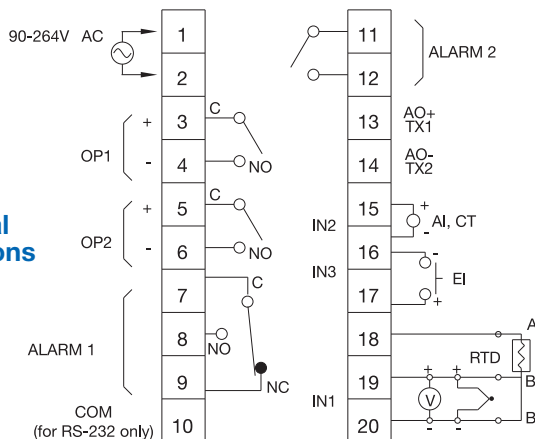

Alarm 1 / Alarm 2

Relay: 2 Amp, 240 VAC **Alarm 1:** SPDT **Alarm 2:** SPST (NO)

Alarm Functions:

Dwell timer PV1-PV2 High / Low Alarm
 Deviation Band High / Low Alarm Loop Break Alarm
 PV2 High / Low Alarm Sensor Break Alarm

Alarm Mode: Normal, Latching, Hold, Latching / Hold

Dwell Timer: 0 - 6553.5 minutes

Data Communications

Interface: RS-232 (1 unit), RS-485 (up to 247 units)

Protocol: Modbus Protocol – RTU mode

User Interface

Dual 4-digit LED Display: 0.55" (14 mm) Red Process Display

Keypad: 3 keys 0.40" (10 mm) Green Setpoint Display

Programming Port: For automatic setup, calibration and testing

Control Mode

Output 1: Reverse (heating) or direct (cooling) action

Output 2: PID cooling control, cooling P band 255% of PB

On-Off: 0.1 - 100.0 $^\circ\text{F}$ hysteresis control (P band = 0)

P or PD: 0 - 100.0% offset adjustment

PID: Fuzzy logic modified

Proportional band: 0.1 - 932 $^\circ\text{F}$ (500 $^\circ\text{C}$)

Integral: 0 - 1000 seconds **Derivative:** 0 - 360 seconds

Cycle Time: 0.1 - 100 seconds

Manual Control: Heat (MV1) and Cool (MV2)

Auto-tuning: Cold start and warm start

Failure Mode: Auto-transfer to manual mode with sensor break or A-D converter damage

Ramping Control: 0 - 900 $^\circ\text{F}/\text{min}$ or 0 - 900 $^\circ\text{F}/\text{hr}$ ramp rate

Power Limit: 0 - 100% for output 1 and output 2

Remote Setpoint: Programmable range for voltage or current input

Digital Filter: Time constant: settable from 0.2 to 60 seconds

Analog Retransmission

Analog Retransmission Functions: PV1, PV2, PV1-PV2, PV2-PV1, Setpoint, MV1, MV2, PV-SV deviation value

Output Signal: 4-20 / 0-20 mA, 0-1, 0-5, 1-5, 0-10 VDC

Accuracy: ±0.05 % of span, ±0.0025 $^\circ\text{C}$

Environmental and Physical

Operating Temperature: 14 to 122 $^\circ\text{F}$ (-10 to 50 $^\circ\text{C}$)

Humidity: 0 to 90% RH, non-condensing

Dielectric Strength: 2000 VAC, 50/60 Hz for 1 minute

Dimensions: 3-3/4 × 3-3/4 × 2-9/16" (96 × 96 × 65 mm) H×W×D
 Depth behind panel: 2" (53 mm)

Panel Cutout: 3-5/8" × 3-5/8" (92 × 92 mm) H×W

Weight: 0.56 lb. (255 grams)

Approval Standards

Safety: UL873,

EN61010-1 (IEC1010-1)

Protective Class: IP 20 housing & terminals with protective covers

EMC: EN61326

Stock and Common Part Numbers

(Power Input: 90-264 VAC, no alarm 2, no data com)

Part Number	Signal Input	Out 1	Out 2	Alarm 1
TEC55001	tc-J	relay	none	relay
TEC55002	tc-J	relay	relay	none
TEC55003	tc-J	relay	relay	relay
TEC55004	tc-J	4-20 mA	none	none
TEC55005	tc-J	4-20 mA	none	relay
TEC55006	tc-J	DC pulse	none	none
TEC55007	tc-J	DC pulse	none	relay