



Series 20 Tapered Shank with .260" Bore for 1/4" Diameter Elements

Heavy Duty Threaded

Series 20 Standard Sizes

Part Number	External Thread "P"	Element Length "A" (in)	Insertion Length "U" (in)	Shank Diameter "B" (in)
TWL2021	3/4" NPT	4	2 1/2	—
TWL2022		6	4 1/2	7/8
TWL2023		9	7 1/2	7/8
TWL2024		12	10 1/2	7/8
TWL2025		15	13 1/2	7/8
TWL2026		18	16 1/2	7/8
TWL2028	24	22 1/2	7/8	
TWL2031	1" NPT	4	2 1/2	—
TWL2032		6	4 1/2	1 1/16
TWL2033		9	7 1/2	1 1/16
TWL2034		12	10 1/2	1 1/16
TWL2035		15	13 1/2	1 1/16
TWL2036		18	16 1/2	1 1/16
TWL2038	24	22 1/2	1 1/16	

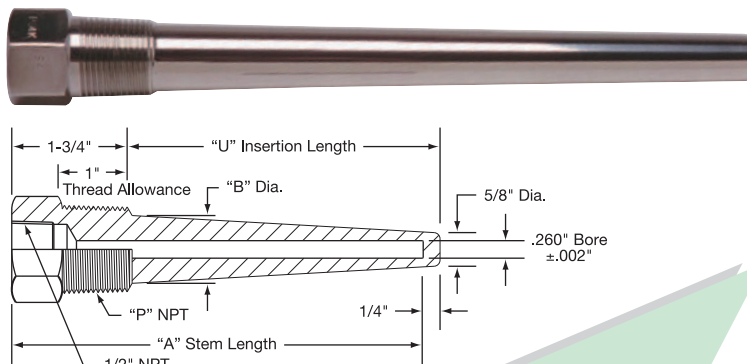

Thermowells are available in the following materials: Steel, Brass, 316 Stainless Steel, 304 Stainless Steel and Monel.

For Ordering Information See Page 14-78

Series 25 Tapered Shank-Lagging Extension Type with .260" Bore for 1/4" Diameter Elements

Heavy Duty Threaded

Series 25 Standard Sizes

Part Number	External Thread "P"	Lagging Extension "T" (in)	Stem Length "A" (in)	Insert Length "U" (in)	Shank Diameter "B" (in)
TWL2521	3/4" NPT	2	6	2 1/2	—
TWL2522		3	9	4 1/2	7/8
TWL2523		3	12	7 1/2	7/8
TWL2524		3	15	10 1/2	7/8
TWL2525		3	18	13 1/2	7/8
TWL2527		3	24	19 1/2	7/8
TWL2531	1" NPT	2	6	2 1/2	—
TWL2532		3	9	4 1/2	1 1/16
TWL2533		3	12	7 1/2	1 1/16
TWL2534		3	15	10 1/2	1 1/16
TWL2535		3	18	13 1/2	1 1/16
TWL2537		3	24	19 1/2	1 1/16

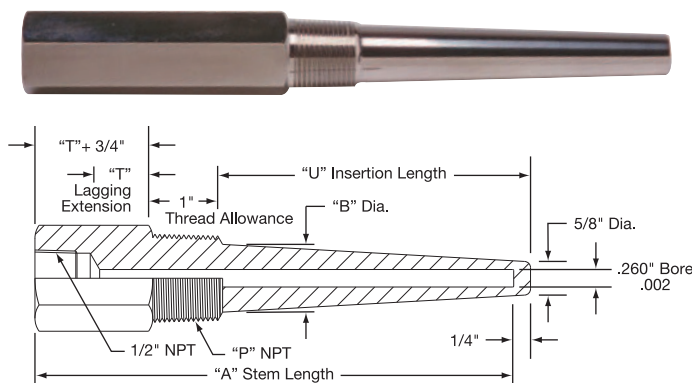

Maximum Fluid Velocity Feet Per Second (See Velocity Ratings on page 14-76)

Well Type	Material	Insertion Length — "U" (in)							
		2 1/2	4 1/2	7 1/2	10 1/2	13 1/2	16 1/2	19 1/2	22 1/2
3/4" Series 20 and 25	Brass	305 (97.5)	93.8 (54.1)	33.9	17.1	10.5	7.0	5.0	3.7
	Carbon Steel	386 (175)	180 (97.2)	65.3 (58.3)	33.0	20.1	13.4	9.6	7.1
	A.I.S.I. 304 & 316	440 (243)	197 (135)	71.2	36.0	22.0	14.7	10.5	7.8
	Monel	354 (195)	155 (108)	56.1	28.4	17.3	11.6	7.5	5.6
1" Series 20 and 25	Brass	354 (161)	108 (89.5)	39.4	19.8	12.2	8.1	5.8	4.3
	Carbon Steel	448 (289)	209 (161)	75.7	38.4	23.3	15.5	11.1	8.2
	A.I.S.I. 304 & 316	490 (403)	228 (225)	82.5	41.8	25.5	17.1	12.2	9.1
	Monel	410 (322)	179 (178)	65.1	33.0	20.1	13.5	8.7	6.5



Note: Where single values appear in table, thermowell may be considered safe for water, steam, air or gas. The values in parentheses in the shorter insertion lengths represent safe values for water flow, taking into consideration the velocity pressure effect of water flowing at higher velocities.

Pressure — Temperature Rating (lbs. per square inch)

Material	Temperature						
	70°F	200°F	400°F	600°F	800°F	1000°F	1200°F
Brass	5300	4750	1100	—	—	—	—
Carbon Steel	5950	5750	5450	5250	4000	1750	—
A.I.S.I. 304	7800	7050	6400	6150	6000	5190	1875
A.I.S.I. 316	7800	7800	7250	7100	6950	5800	2720
Monel	7450	6850	6150	6100	5940	1750	—