

Ceramic Fiber Heater Features and Options

Construction Characteristics

Tempco's standard Ceramic Fiber Heaters are designed for a maximum temperature of 1100°C (2012°F). The resistance wire is wound in a helical coil and embedded flush to the heater surface.

Tempco's High Temperature Ceramic Fiber Heaters are designed for a maximum temperature of 1200°C (2192°F). The resistance ribbon wire is helically wound and mounted at the heater surface using a method that exposes three sides of the coil.

The availability of High Temperature (1200°C) Ceramic Fiber Heaters is very limited. Consult Tempco with your requirements.

Unheated Molded Ceramic Fiber Panels and Cylinders

Tempco can manufacture unheated ceramic fiber panels, full and semi-cylinders for applications that require additional insulation. For example, flat circles can be made to cover the top or bottom of a cylindrical shaped heater to produce a small furnace. The unheated insulation components are made from a similar material as the heaters, so the specifications are the same.

To order, consult Tempco with your requirements.

Thermowells

Quartz glass thermowell tubes can be inserted perpendicular to the heater, usually all the way through, for use with temperature probes to sense the interior temperature. The sensor probes are ordered separately. For a typical thermocouple sensor probe, see page 14-14, MTA1.

For .125" diameter sensor probes, specify a 4mm ID thermowell tube.
For .187" diameter sensor probes, specify a 6mm ID thermowell tube.
For .250" diameter sensor probes, specify an 8mm ID thermowell tube.

Optional Vestibules on Full and Semi-Cylindrical Heaters

Vestibules are used to support full or semi-cylindrical heaters around a pipe to heat the material flowing through the pipe. The vestibule is made from 1" ceramic fiber board cut to the correct OD and ID and then cemented to one or both ends of standard size full or semi-cylindrical heaters. The overall length for standard vestibules would be the original heater plus 2" for a vestibule on both ends or 1" for a vestibule on one end. It is recommended that for maximum temperatures, a vestibule width of 1.5" to 2" be specified.

Full cylindrical heaters with (two) vestibules are available with Type 1, 4, or 5 leads.

Semi cylindrical heaters with (two) vestibules are available with Type 1 or 3 leads.

To order, consult Tempco with your requirements.

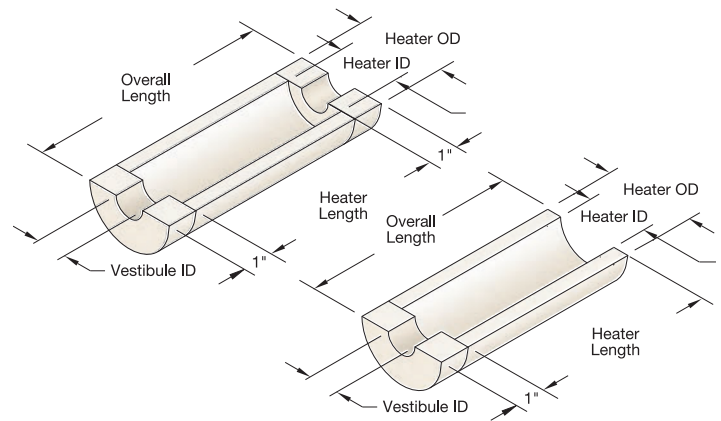

Mounting / Repair Accessories

Rigidizer

The external surface of ceramic fiber heaters is treated with a chemical rigidizer to give the heater the hardened shell typical of this type of heater. When the ceramic heater is cut in the field prior to installation for any purpose, or repairs are required, rigidizer should be used to recoat the surface.

Part Number: CFR00010 **Quantity:** 1 Gal.

Ceramic Fiber Cement

The cement has many general purposes, such as bonding ceramic fiber heaters together or adding additional external insulation.

Part Number: CFR00020 **Quantity:** 1 Gal.

Ceramic Putty

Made from high purity Asbestos-Free Aluminum Oxide-based ceramics with a melting point in excess of 3200°F (1760°C) and formulated with special ceramic binders that, on drying, produce a strong ceramic body.

- ✓ **Resistant** to molten metals, most chemicals, oxidizing and reducing atmospheres.
- ✓ **Use for installation/repairs** to brick, mortar, burner blocks, insulation, furnace holders, thermocouples, etc.
- ✓ **Applications include:** bonding and bonding ceramic fiber components, high temp. insulation, insulation of pipes, supports, burners, turbines, etc.

Size: 4 oz. Squeeze Tube **Part Number:** CFR00030

Size: 11 oz. Caulking Tube **Part Number:** CFR00032

SPECIFICATIONS

Melting Point	3200°F (1760°C)
Continuous Service	2300°F (1260°C)
Base Material	Al ₂ O ₃
Density	40-50 lbs./cu. ft.
Specific Heat	0.25 BTU/# °F
Dielectric Constant at 10 ⁸ cps	1.61
Loss Factor	0.017
Dielectric Strength	100 Volts/mm
Thermal Conductivity at 500°F (260°C) ...	0.65