

Stock Reflectors for CRB, CRN, CRC, CRZ and CRL E-Mitters

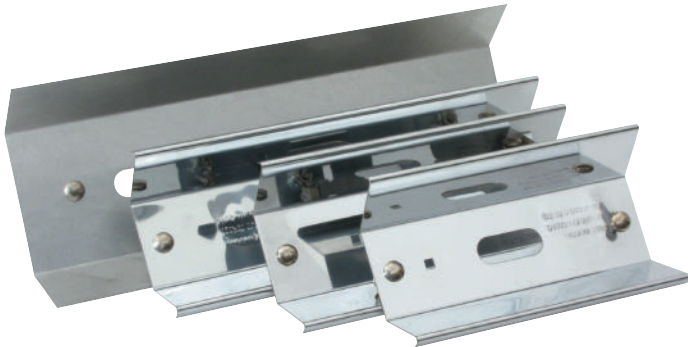

Reflectors for Ceramic E-Mitters

- * Designed to withstand bending and heat distortion.
- * Made from highly polished chrome steel or optional aluminized steel for extreme temperatures and harsh environments.
- * Will withstand high operating temperatures.
- * Available in three standard sizes; includes standoffs and hardware.
- * Easy installation into CRA linear structural housing assemblies (except CRK00032).

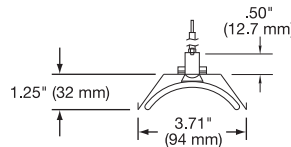
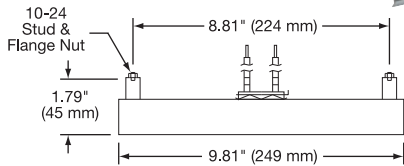

For One CRB E-Mitter or One CRN E-Mitter

Part Number: CRK00007 (Chrome Steel)
Part Number: CRK00049 (Aluminized Steel)

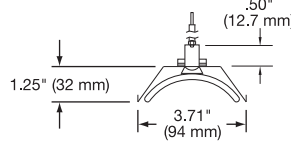
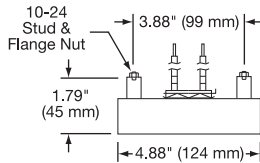

For One CRC E-Mitter or One CRZ E-Mitter

Part Number: CRK00006 (Chrome Steel)
Part Number: CRK00035 (Aluminized Steel)

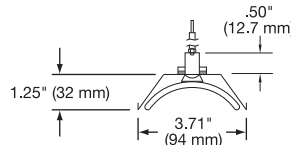
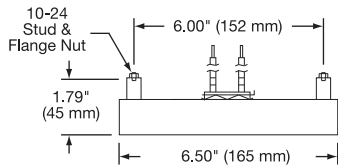

For One CRM E-Mitter

Part Number: CRK00030 (Chrome Steel)
Part Number: CRK00074 (Aluminized Steel)

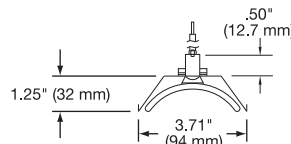
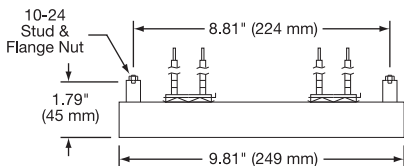

For Two CRC E-Mitters or Two CRZ E-Mitters

Part Number: CRK00020 (Chrome Steel)
Part Number: CRK00043 (Aluminized Steel)

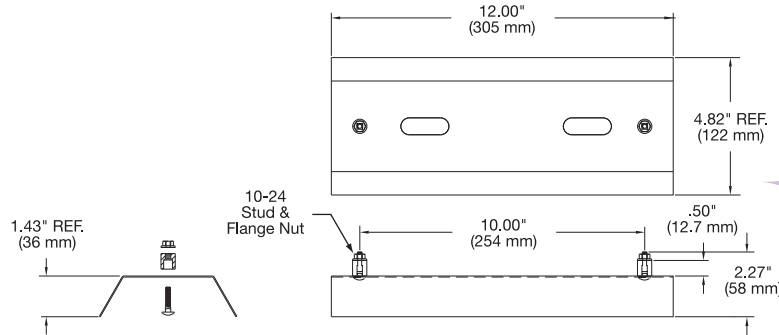

Note: Reflectors in drawings are shown with curved heater(s) for reference only.

For One CRL E-Mitter

Part Number: CRK00032 (Aluminized Steel)

All Items Available from Stock

Ceramic Twist-Loc Wire Connectors

Porcelain Material, Maximum Temperature Rating 1200°F (645°C), 300V Maximum

Agency Approvals: UL and CSA for EHD-114-102, EHD-114-103 and EHD-114-104 (UL File E9809)

Stock Number	MFR Part Number	Wire Range (Solid or Stranded Wire)		Skirt Length	Opening ID	Outer Diameter
EHD-114-102	10-401	2#22	1#18 + 1#16	.687"	.250"	.406"
EHD-114-103	10-405	2#20	2#16	.750"	.312"	.484"
EHD-114-104	10-407	2#18	2#14	.843"	.406"	.531"
EHD-114-105	-	1#16 + 1#14	1#14 + 2#12	1.00"	.468"	.703"

