

Type CRE Edison Screw-In Bulb E-Mitters

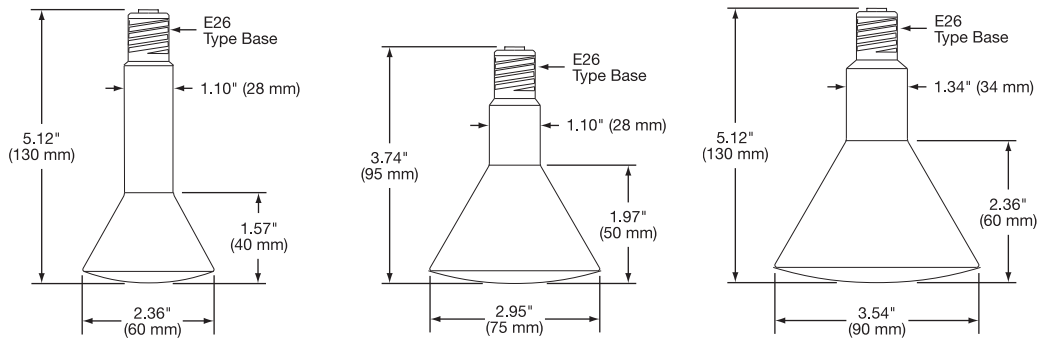

Standard (Non-Stock) CRE E-Mitters

Diameter	Wattage	Voltage	Color	Watt Density		*Surface Temperature (Typical)		Part Number
				(W/in ²)	(W/cm ²)	°F	°C	
60mm	60	120	Rose to Grey	13.26	6.45	842	450	CRE10014
	60	120	White	13.26	6.45	842	450	CRE00014
	100	120	Rose to Grey	22.60	10.76	887	477	CRE10015
	100	120	White	22.60	10.76	887	477	CRE00015
75mm	60	120	Rose to Grey	8.49	1.32	662	350	CRE10012
	60	120	White	8.49	1.32	662	350	CRE00012
	100	120	Rose to Grey	14.15	2.19	788	420	CRE10013
	100	120	White	14.15	2.19	788	420	CRE00013
90mm	150	120	Rose to Grey	15.59	2.41	842	450	CRE10008
	150	120	White	15.59	2.41	842	450	CRE00008
	250	120	Rose to Grey	22.98	4.02	986	530	CRE10002
	250	120	White	22.98	4.02	986	530	CRE00002

Type CRR Edison Screw-In Bulb E-Mitters

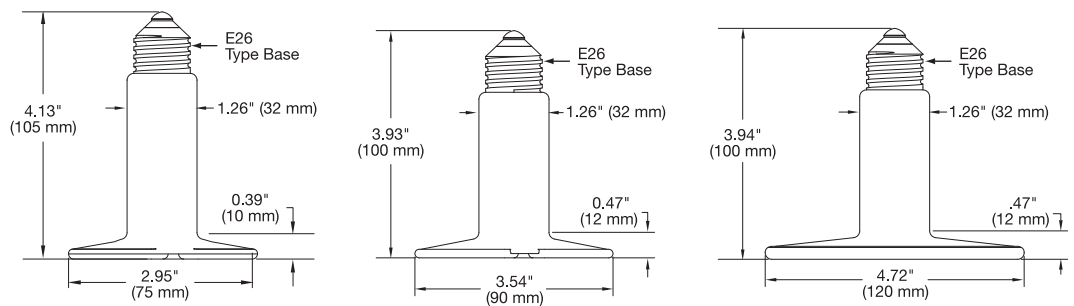

Standard (Non-Stock) CRR E-Mitters (Color – White)

Diameter	Wattage	Watt Density		*Surface Temperature (Typical)		Part Number 120V
		(W/in ²)	(W/cm ²)	°F	°C	
75mm	60	8.77	1.36	640	338	CRR00005
	100	14.62	2.26	710	377	CRR00006
	100	10.16	1.57	655	346	CRR00003
90mm	150	15.24	2.36	760	404	CRR00004
	200	20.32	3.14	950	510	CRR00007
	100	5.71	0.88	400	204	CRR00008
120mm	150	8.57	1.33	485	252	CRR00009
	200	14.29	2.21	670	354	CRR00010

*E-Mitter (operating in 72°F/22°C ambient) face temperature measured with internal thermocouple.