

MAXISTRIP®

**A Reliable Heat Source with
Excellent Heat Transfer
Capabilities Due to the
Aluminum Shoe Construction**

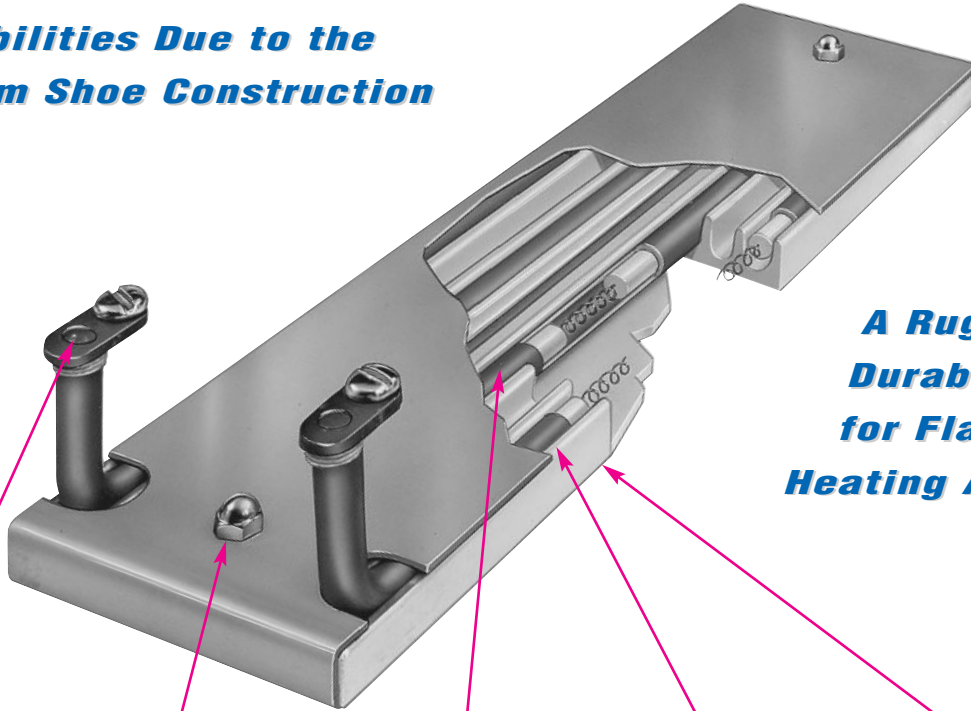

**A Rugged and
Durable Heater
for Flat Surface
Heating Applications**

A Right-angle lug terminals with 10-32 binding head screws provide ease of electrical wiring.

B Crown nuts securely fasten the cover plate to the aluminum track, keeping contaminants from coming in direct contact with the tubular heating element.

C Ruggedly constructed .315 diameter heating elements are the heat source for Maxistrip heaters, providing excellent life and long, trouble-free service.

D Specially designed aluminum track houses the tubular heating element, providing an excellent heat sink for rapid heat transfer and good temperature uniformity.

E The surface contact on Maxistrip heaters is smooth and flat, which is essential for good heat conduction. This results in exceptionally long heater life.

TEMPCO Maxistrip Heaters are specially designed and engineered for trouble-free performance and more efficient heating of flat surfaces. Due to the rugged construction characteristics of this type of strip heater, it is highly recommended for applications requiring excellent heat transfer and temperature uniformity.

Design Features

- * Quick Installation
- * Contamination Proof
- * Various Lead Terminations
- * Excellent Heat Transfer
- * Excellent Temperature Uniformity
- * Designed for Durability and Trouble-Free Service

Typical Applications

- ➔ Extrusion Dies
- ➔ Molds
- ➔ Hot Plates
- ➔ Drying
- ➔ Incubators
- ➔ Platens
- ➔ Sealing Bars
- ➔ Thermoforming
- ➔ Tank Heating
- ➔ Food Warmers



Note: Mounting holes can be provided down the center. For other locations see drawings on page 8-17.