

Terminations

Continued from previous page...

Type R2 Right-angle armor cable prevents contamination from getting into the heater. 10" of armor over 12" long leads is standard; if longer leads or armor are required, please specify.

Maximum Amps: 10 at 240VAC **Maximum Volts:** 480

Type R2A Galvanized cable

Type R2B Stainless steel cable

Type R2C Elbow and leads only (no cable)

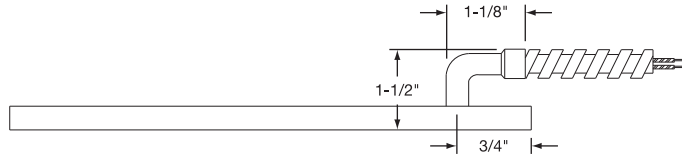

No Mounting Tabs

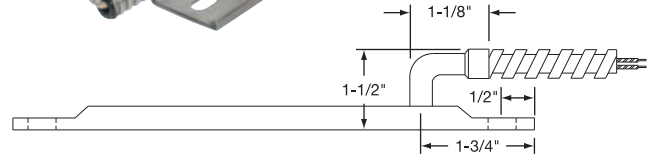
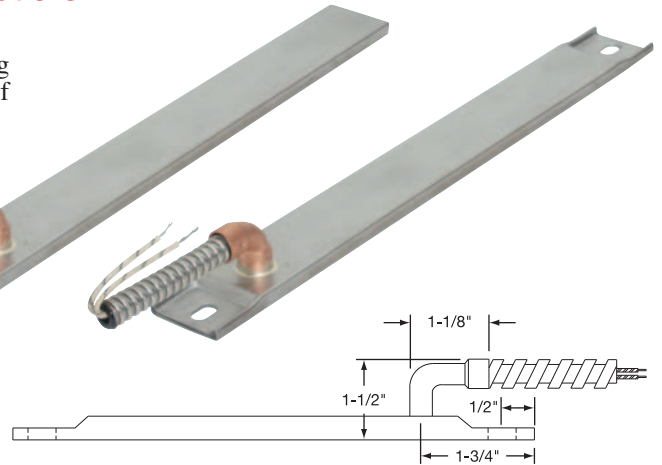

With Mounting Tabs

Terminal Protection

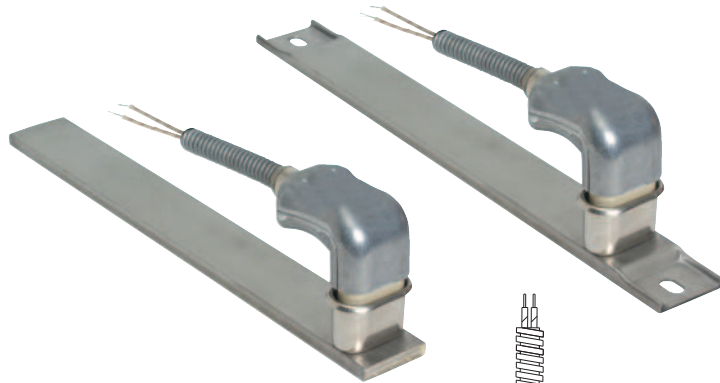

Type P High-Temperature Quick Disconnect Plug. If armor protected lead wires are required, specify armor and lead length. Available on 1-1/2" wide heaters only.

Maximum Amps: 10 at 240VAC **Maximum Volts:** 250

Type P1A Cup only (UT900)

Type P1B Cup and straight plug (H900)

Type P1C Cup and 90° plug (HW900)

Type P1D Cup, straight plug and galvanized cable

Type P1G Cup, 90° plug and galvanized cable

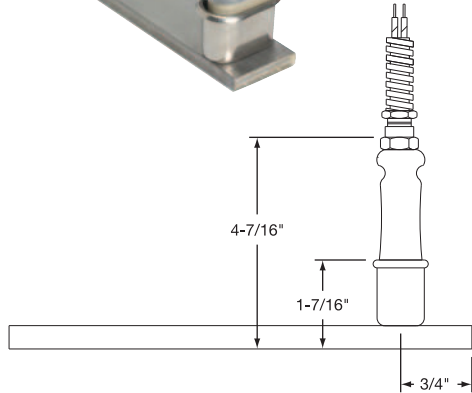

No Mounting Tabs (Type P1D Shown)

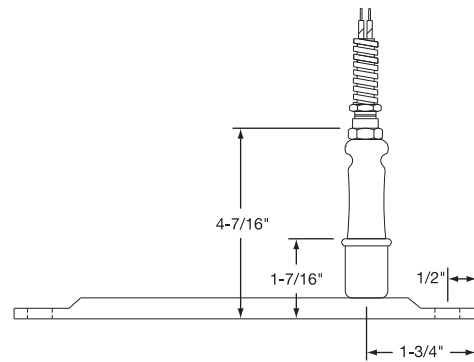

With Mounting Tabs (Type P1D Shown)

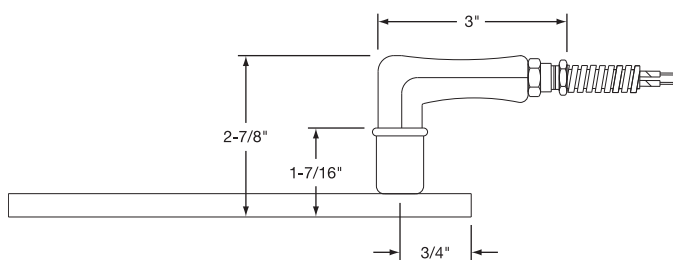

No Mounting Tabs (Type P1G Shown)

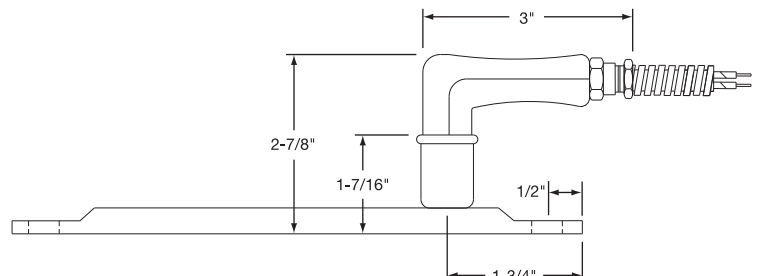

With Mounting Tabs (Type P1G Shown)

Exposed electrical wiring on Strip Heaters is a violation of electrical safety codes, including O.S.H.A.