

TEMPCO®

PPS Series Quick Start Data Recorder



TABLE OF CONTENTS

1.	GENERAL DESCRIPTION.....	5
1.1	UNIQUE FEATURES OF RECORDER.....	5
1.2	COMPARISON OF PPS SERIES RECORDERS	5
1.3	SMART MECHANISM	6
2.	INSTALLATION AND WIRING	7
2.1	UNPACKING	7
2.2	INSTALLATION	7
2.3	PANEL MOUNTING STYLE	8
2.4	WIRING OF THE CARDS	11
2.5	RS-232, RS-422, AND RS-485 WIRING	15
3.	CONFIGURATION	17
3.1	CHANNEL.....	18
3.1.1	Analog Input	18
3.1.2	Digital Input	24
3.1.3	Math Channel	26
3.1.4	Analog Output	30
3.1.5	Digital Output.....	31
3.1.6	External	31
3.1.7	Jobs	32
3.2	DISPLAY	33
3.2.1	Status Bar	35
3.3	TIMER.....	36
3.4	CLOCK	36
3.5	COMMUNICATION	37
3.5.1	Connections	39
3.5.2	Commands	39
3.6	INSTRUMENT	40
3.7	SECURITY	41
3.7.1	Normal.....	41
3.7.2	CFR-21.....	41
3.8	DEMO.....	42
3.9	AUTO-OUTPU	42
3.9.1	USB Printer	43
3.9.2	Network Printer (LPT1).....	44
3.9.3	Print Historical data.....	45

3.9.4	Print Reports	46
3.9.5	Print Snapshot.....	47
3.10	SYSTEM INFO.....	47
3.11	BATCH CONTROL	49
3.12	CALIBRATE.....	51
3.13	PROCEDURE TO RESET AND RESTORE FACTORY DEFAULT SETTINGS.....	64
3.14	HANDWRITING MESSAGES ON TREND SCREENS.....	66
4.	WEBSERVER.....	69
4.1	HOW TO CONFIGURE WEB SERVER SETTINGS	69
4.1.1	How to Configure Static IP Address	69
4.1.2	How to Enable Web Server.....	70
4.2	HOW TO VIEW RECORDER DATA IN PC VIA WEBSERVER	71

**NOTE: IF THE USER REQUIRES TO KNOW THE FULL
DETAILS OF THE FUNCTIONS, PLEASE REFER
THE FULL USER MANUAL**

Safety

This recorder is compliant with the requirements of EN61010-1, UL 61010C-1 & CSA C22.2 No. 24-93. The protection provided by the recorder may be impaired if it is used in a manner inconsistent with its intended purpose, or in an environment that exceeds the specifications of the recorder. The supplier is not liable if the customer fails to comply with these requirements.

Safety Symbols

The following symbols may be seen in the user manual or on recorder labeling.



Caution



Protective Earth



DC Supply

Safety Notes and Precautions

1. Before any connection is made, the protective earth terminal should be connected first. To avoid making the recorder dangerous under fault conditions, any interruption of the protective Earth conductor inside or outside the recorder is prohibited. Even in the case of a portable unit, the protective earth terminal must remain connected if the recorder is connected to any hazardous voltage.
2. Keep signal and supply voltage wiring separated from one another. If this is impractical, use shielded cables for signal wiring. Double insulation should be used for signal wiring when the recorder is used with hazardous voltage.
3. Do not use the recorder where there is high vibration or a high magnetic field. This could cause damage or error of measurement.
4. All maintenance or repairs should be carried out with power disconnected to avoid personal injury or damage to the unit.
5. In areas with conductive pollution, adequate ventilation, filtering and sealing must be installed.
6. When cleaning the recorder, handle carefully and use soft dry cloth. Avoid the use of abrasives, or any sharp or hard objects which would damage the display.
7. Do not operate the recorder if any part has been removed or disassembled. Consult your nearest dealer at once.

Static Electricity

Appropriate precautions must be taken when handling the recorder. The circuit board components are susceptible to damage caused by electrostatic discharge. Take static electricity precautions while handling and inserting USB memory into the recorder.

1. General Description

1.1 Unique features of recorder

The PPS series is a well-designed new generation paperless recorder with many outstanding features as follows:

Hardware

- Three sizes including 4.3", 5.6" and 12.1"
- PPS-1000, with a 4.3" display, with 3 or 6 universal analog inputs and 24 Optional External Channels
- PPS-2000, with a 5.6" display, with 6, 12, 18 or 24 universal analog inputs and 48 Optional External Channels
- PPS-3000, with a 12.1" display, with 6, 12, 18, 24, 30, 36, 42 or 48 universal analog inputs and 96 Optional External Channels
- TFT Color LCD, Touch screen & high resolution
- 100 millisecond sample rate and data logging
- Process Control card (PC201) to control the process.
- High accuracy 24-bit A-D Analog Input
- 16-bit D-A Analog Output
- Digital input, maximum 100 Hz.
- Plug & play I/O cards (AI, AO, DI, DO) for easy expansion
- On-board SD card slot for Internal memory
- USB slot for external storage
- 171 mm short depth
- Ethernet as standard with optional RS-232 or RS422/RS485 communication
- Two USB Host ports for downloading the data or connect to Printer
- IP65 / NEMA 4X water-resistant

1.2 Comparison of PPS series Recorders

Description	PPS-1000	PPS-2000	PPS-3000
Display Size	4.3"	5.6"	12.1"
Analog Inputs (Maximum)	6	24	48
Math Channels (Maximum)	15	40	60
External Channels (Other devices)	24	48	96
Total Pages	8	20	21
Pens/Page (Maximum)	6	6	10
Batches (Maximum)	1	1	1

1.3 Smart Mechanism

The recorded data is stored in the manufacturer's special binary format. It is not possible to manipulate or modify the recorded data. This feature fully guarantees the security of the data.

Front View:

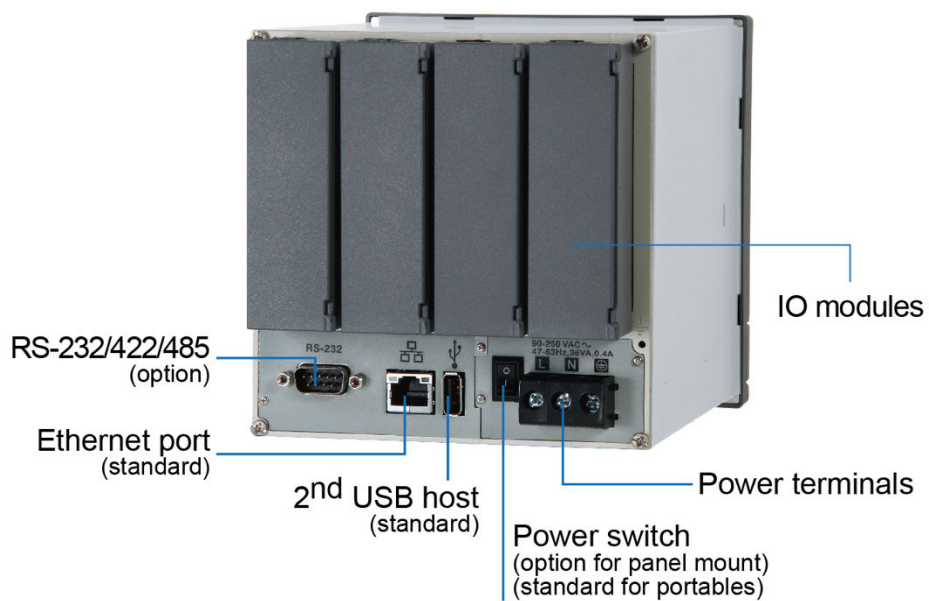
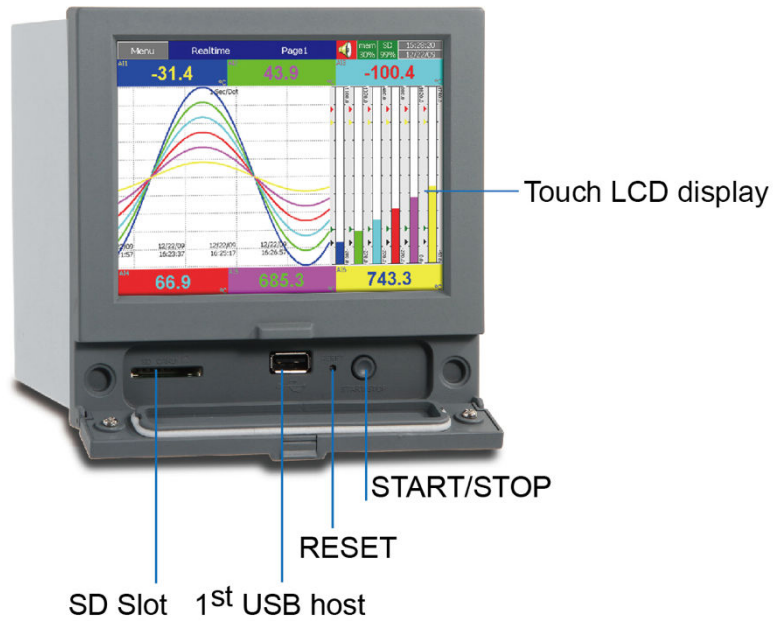

Rear View:

2. Installation and wiring

2.1 Unpacking

If any damage is found while unpacking, the user should contact the local representative at once. It is suggested that the special packaging is retained for possible future requirements.

2.2 Installation

 **Remove stains from this equipment using a soft, dry cloth. Do not use harsh chemicals, volatile solvents such as thinner or strong detergents to clean the equipment in order to avoid deformation.**

The recorder is designed for indoor use and not in any hazardous area. It should be kept away from shock, vibration, and electromagnetic fields such as variable frequency drives, motors and transformers.

It is intended to operate under the following environmental conditions:

Pollution Degree Level II	IEC1010-1(EN61010-1)
Temperature	0 ~ 50 °C
Humidity	20 ~ 90 % RH (non-condensing)
Power	90 ~ 250 VAC, 50/60 Hz or 11-36VDC
Altitude	2000M maximum

2.3 Panel mounting style

PPS-1000:

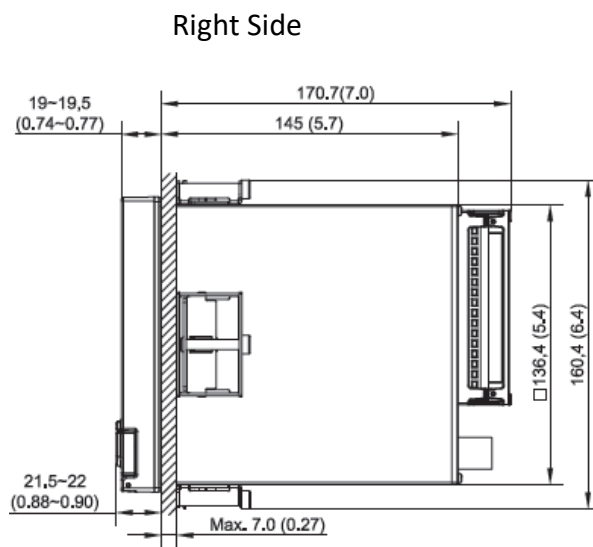
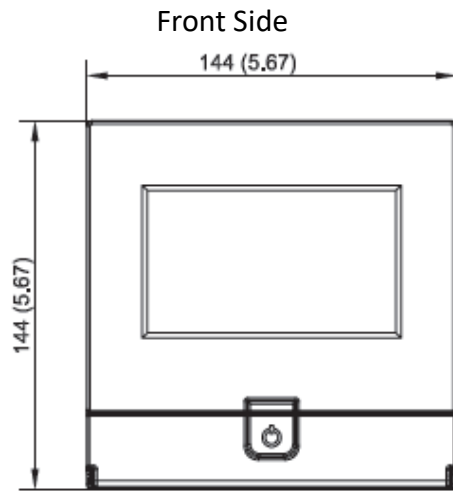

Panel Cut Out Dimensions

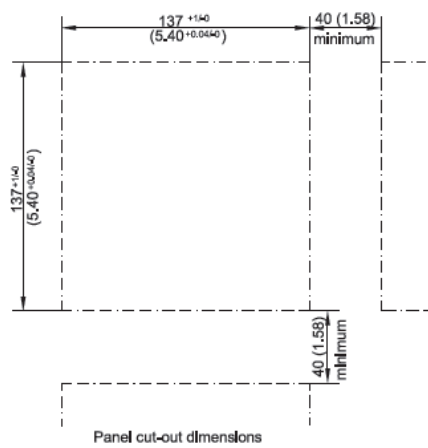

PPS-2000:

Front Side

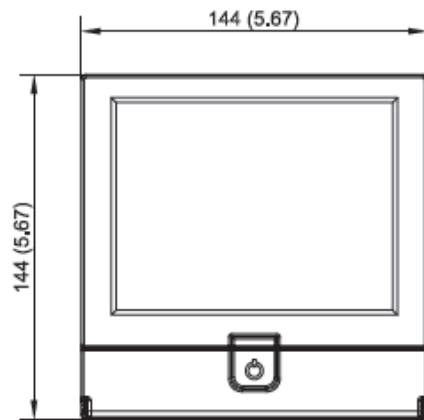

Right Side

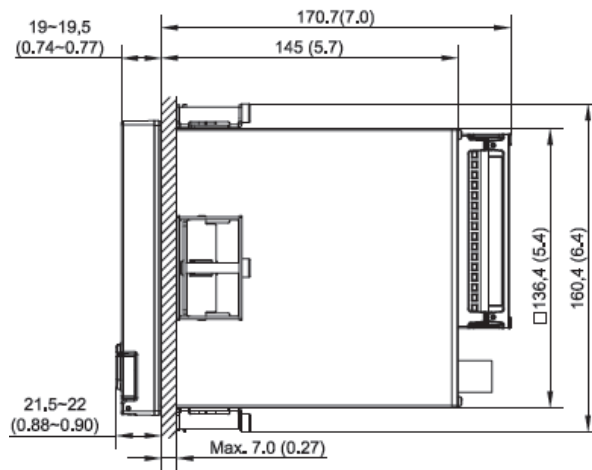

Panel Cut Out Dimensions

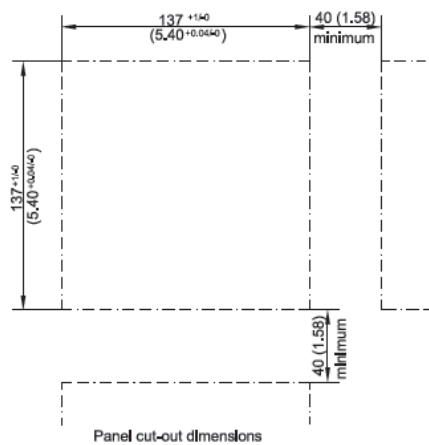

PPS-3000:

Front Side

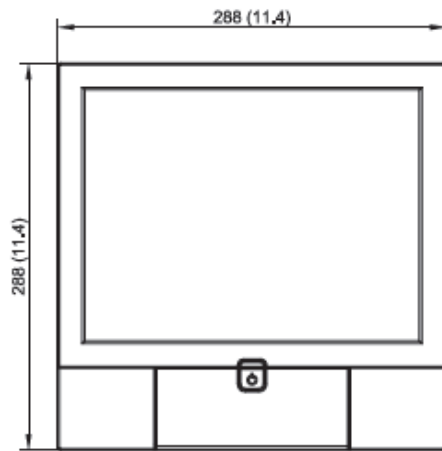

Right Side

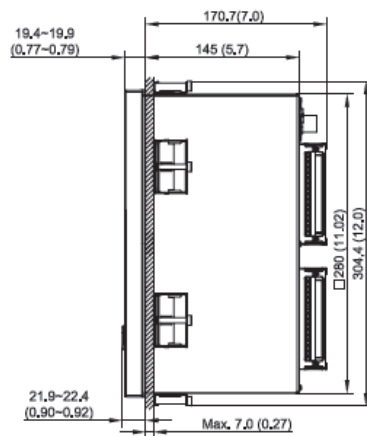

Panel Cut Out Dimensions

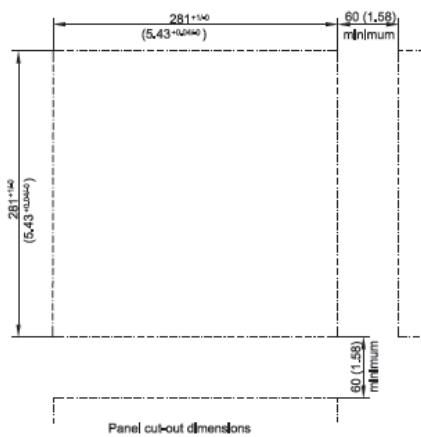

Portable styles:

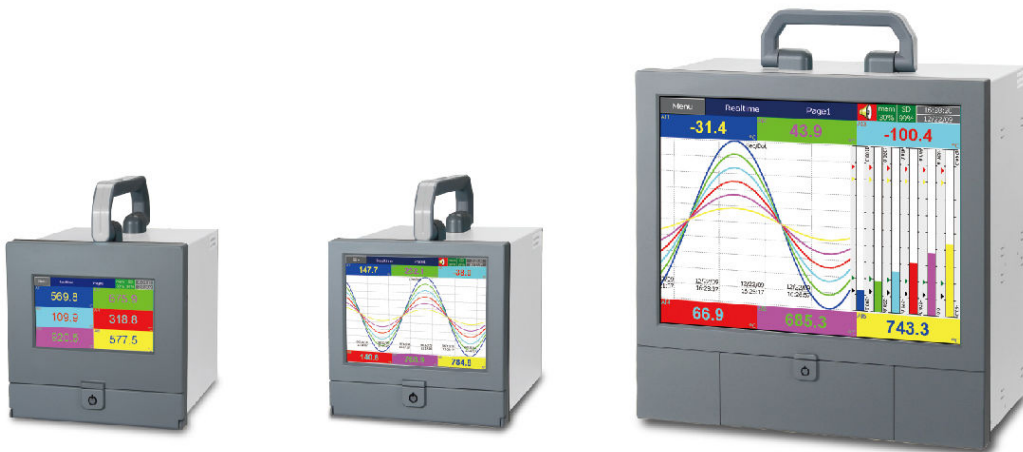

2.4 Wiring of the cards

Wiring Precautions

1. Care must be taken to ensure that the maximum voltage rating specified on the label is not exceeded.
2. For the panel-mount version, it is recommended that near an external fuse or an external switch rated at 2A/250 VAC should be used.
3. Beware not to over tighten the terminals screws. The torque should not exceed 0.4 N-m (3.6 Lb-in or 4.0 Kg F-cm).
4. With the exception of the thermocouple wires, all wires should be stranded copper conductor with maximum gauge of 18 AWG.
5. Connect a grounding conductor with 1.6mm diameter minimum to provide protective grounding prior to turning on the equipment.

Analog Input Card PPS90001/AI206

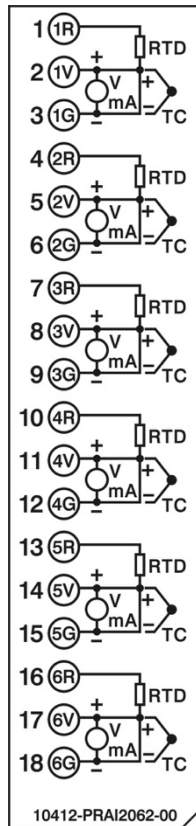

Analog Input Card PPS90002/AI203

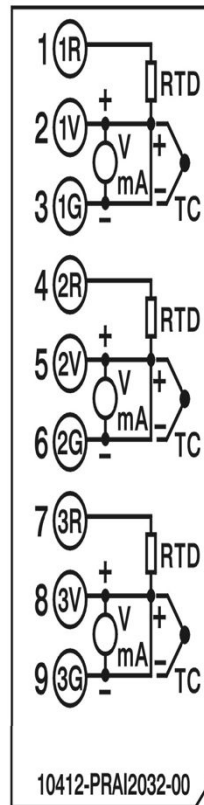

Relay output card PPS90003/RO206

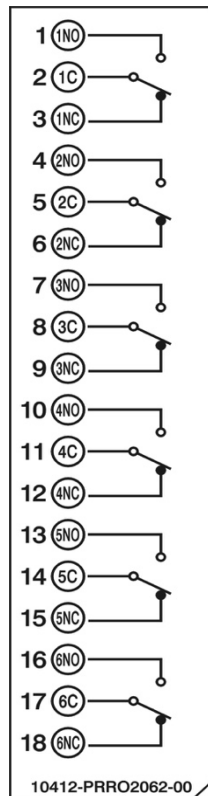

Digital input card PPS90004/DI206

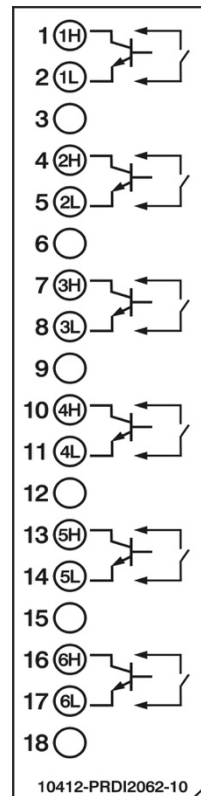

Relay output / digital input card PPS90005/RD233 Analog output card PPS90006/AO206

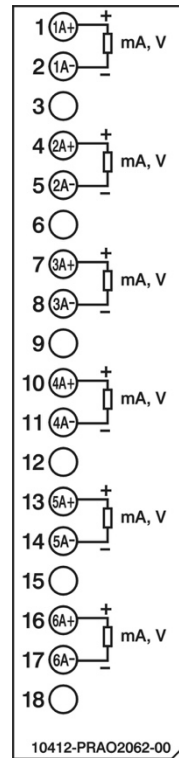
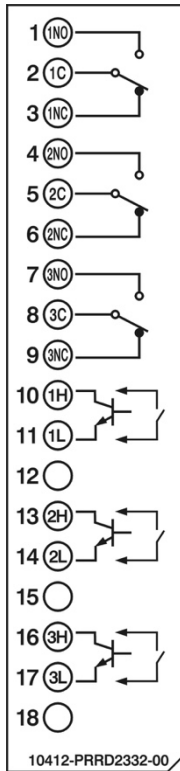

PID Control card PPSPCM/PC201

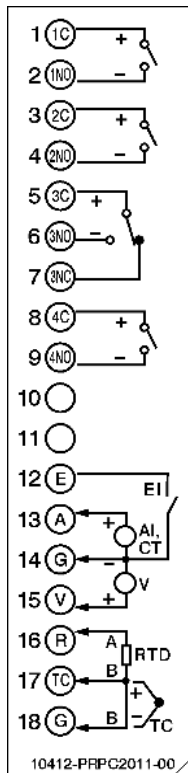

Note 1: The IO Cards should not be removed or Inserted to the PPS when the Power is ON. This should only be done when the recorder power is OFF.

Note 2: For Thermocouple Inputs, a 1 hour warm up is necessary for initial set up.

Note 3: Information regarding removing the IO Cards from PPS.

For removing the IO Card, First remove the metal screws then plastic screws, after that press the lock on the top and bottom of the Card and pull to remove it. Failing to do so will damage the IO Card. Please follow the below pictures for more information.

The Maximum Torque for the metal screw is 3Kg-cm (2.6in-lb) and the Maximum Torque for the plastic screw is 0.8Kgf-cm (.7in-lb)

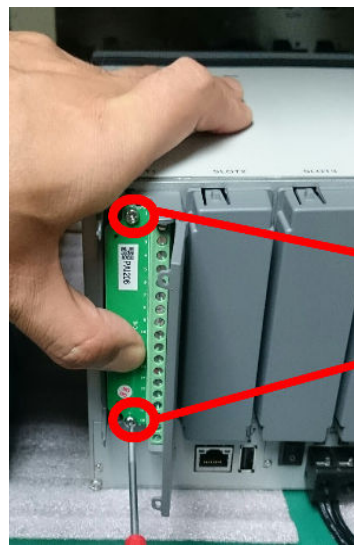
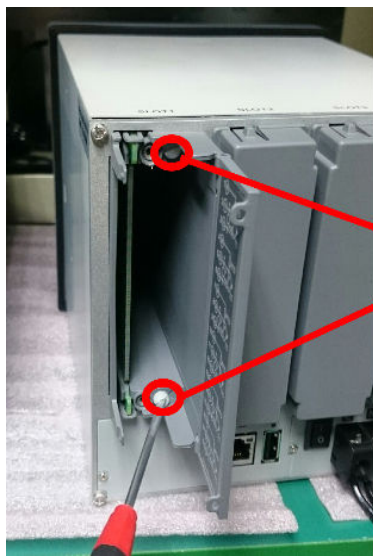

Note 4: For the PPS-3000, Analog Input card should be inserted in slots 1 to 8 only.

AI Cards should not be inserted into slots 9 to 16.

Note 5: Circular Trends are only available for the PPS-3000 mode

Note 6: In the PPS-3000, the Analog Input card should be inserted in slots 1 to 8 only. It should not be inserted in slots 9 to 16.

Note 7: For some industries who prefer/favour circular displays, PPS-3000 can offer this

unique feature and set the display speed for each page/circle in 30 minutes, 1, 2, 4, 8, 12 hours, or 1, 2 days, or 1, 2, 4 weeks.

Note 8: Calibrate: Sometimes the field calibration is required for high accuracy. In this case, a qualified engineer can do the necessary calibration.

2.5 RS-232, RS-422, and RS-485 wiring

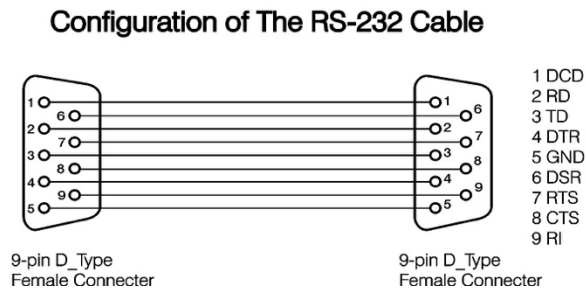
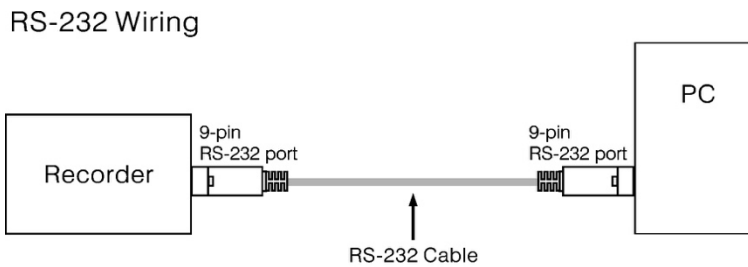
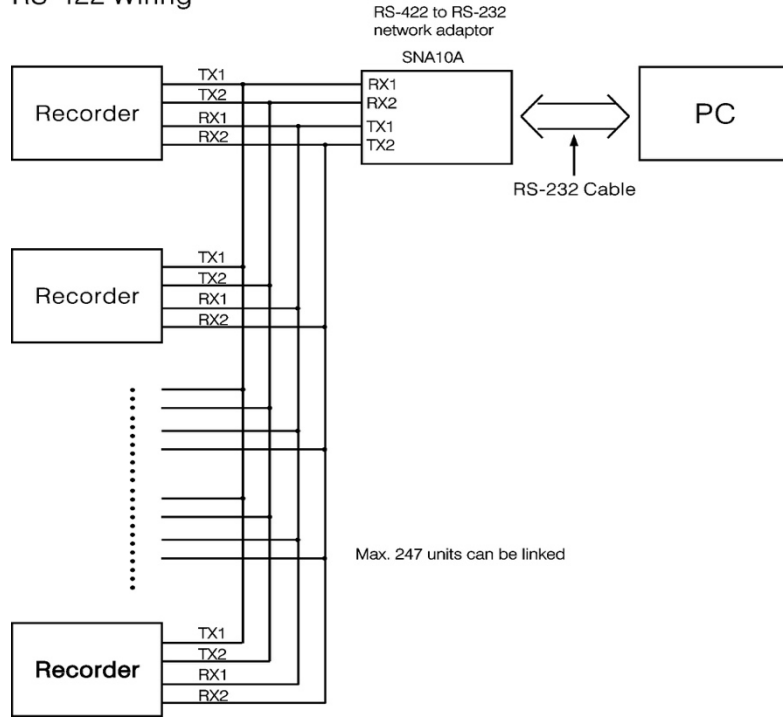
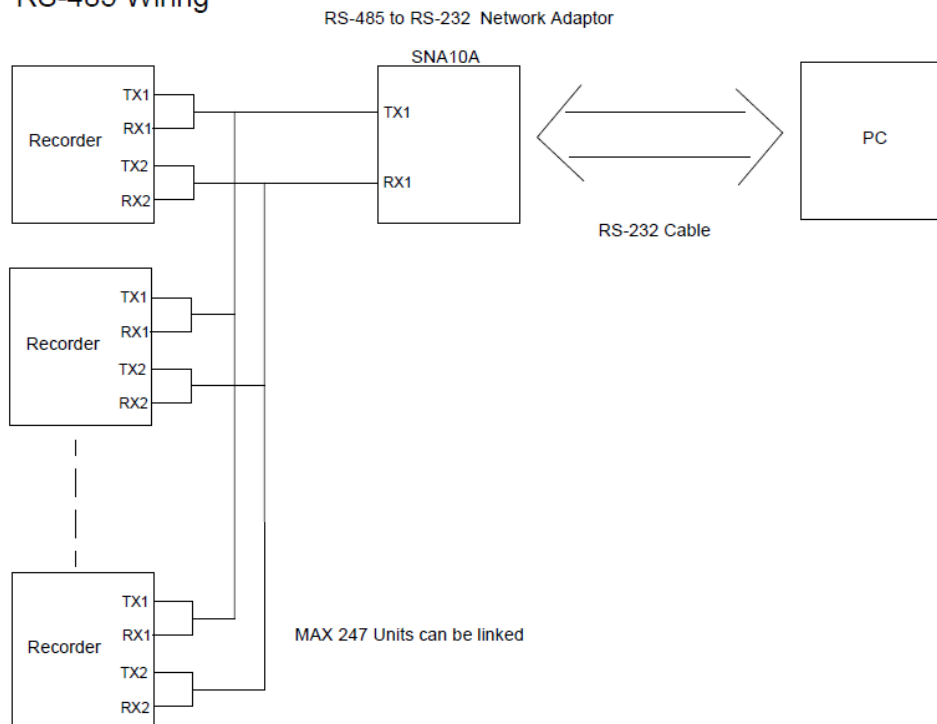

Figure 2 – 24

RS-422 Wiring



RS-485 Wiring



3. CONFIGURATION

Press  (“Menu”), then the “More” soft button to enter Configuration mode.

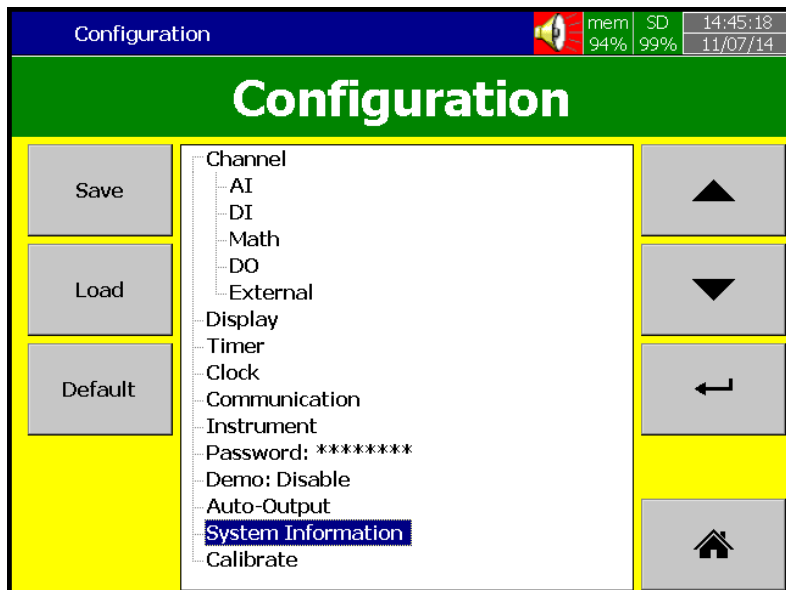

Soft buttons

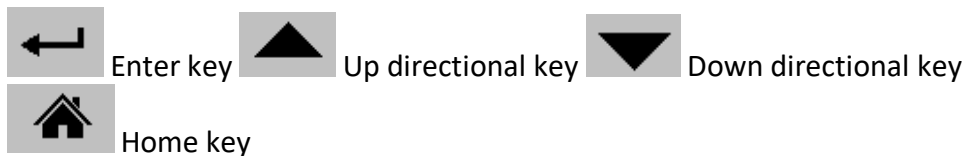

Various options are available to enter into configuration mode

Option-1: Select the mode by pressing up & down directional keys, then press “Enter” key

Option-2: Select the required mode directly with a touch, then press “Enter” key

Option-3: Select the required mode by pressing the mode two times quickly, it is same as a double click from a mouse

Save: Save configuration from the recorder to a USB Stick or an SD Card.

To read the configuration from a USB Stick for the first time or any time the configuration has been changed, it is important to press the “Save” soft button to save configuration changes to the USB Stick or SD Card beforehand.

Load: Load configuration from a USB stick or SD Card to the recorder.

Default: If the configuration is set incorrectly, “Default” is a useful key to recall the default settings for the analog input card inserted into rear expansion slot.

Home: Returns the User to the home page.

3.1 Channel

Path:  (Menu)-More-Config-Channel

This section is to configure different type of channels. Analog Input (AI), Digital Input (DI), Math, Analog Output (AO), Digital Output and External device channels.

3.1.1 Analog Input

After entering the Configuration mode, in “Channel”, select “AI”, then Press the “Enter” key to get into Analog Input Channel mode. It displays the Analog input AI1 as the first analog input channel configuration page. Press directional keys < > at the bottom to select other channels. Press directional keys ↑↓ on the right-hand side to select the column. **After completing Configuration, press “Back” soft button, then press “Home” soft button to return to main display. All configurations will be saved automatically.**

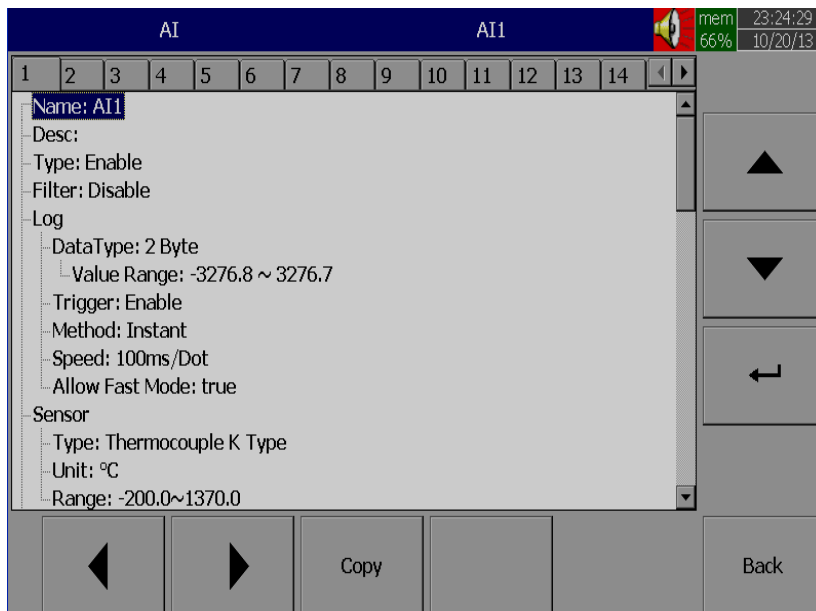

Copy: For example, to copy the channel configuration from channel 1 to channel 2, select the source channel, in this case AI1 (or whatever the channel is named), press on “Copy” button. Now, a “Paste” button will get enabled, go to target channel, say channel 2, and then press on “Paste” button.

Name: Enables the User to define the name for each channel with a maximum of 18 characters.

Select “Name”, then Press “Enter”, soft button, a keyboard with several keys appear. Press “Shift” to select special characters. Press “Caps” to select capital letters. Press soft key “OK” after entering a new channel name.

Desc: The description about a specific channel on the display.

Type: Option available to enable or disable the channel from selection

Filter: It is to reduce the noise of input signal before sampling. It is possible to select range from 1 to 16 sec. It is a soft filter available to reduce fast variation of analog inputs. It gives a moving average value. For example, if the filter value is set as 5 sec for AI1, it means all the samples collected in the last 5 sec shall be averaged, and the value is available to record as per Log method.

Moving Average: This takes Average of the values recorded in (entered) Buffer Time.

Difference: It is current value and last value difference. Allowance will define difference allowance. Holding time minimum is 100ms.

Example:

if current value 1000 and last value is 890, when you check the difference is 110. Since this difference is greater than 100 during holding time. This value will be recorded. If the current value is 900, since it less than 100 during the holding time, this value will not be recorded. So, the holding time will define the duration.

Log:

Data Type: 2 byte

2 byte range: -32767 to +32767

Trigger: Two options are available

a) **Disable:** Select disable while the recording of a specific channel is not required at this time

b) **Enable:** Select Enable while the recording of a specific channel is required at this time

Method: This is the method of logging measured data. Select the column and press "enter". Then choose the Log method of Instant, Average, Minimum or Maximum data.

Instant: logging the last measured data at the sampling interval

Average: logging the averaged measured data at the sampling interval

Minimum: logging the minimum measured data at the sampling interval

Maximum: logging the maximum measured data at the sampling interval

Speed: It is the logging speed (recording speed) of measured data. Select Log Speed column, then choose one of the following

- 100ms/Dot**
- 1 Sec/Dot
- 2 Sec/Dot
- 5 Sec/Dot
- 10 Sec/Dot
- 20 Sec/Dot
- 30 Sec/Dot
- 1 Min/Dot
- 2 Min/Dot

(Auto) Set Jobs under Events

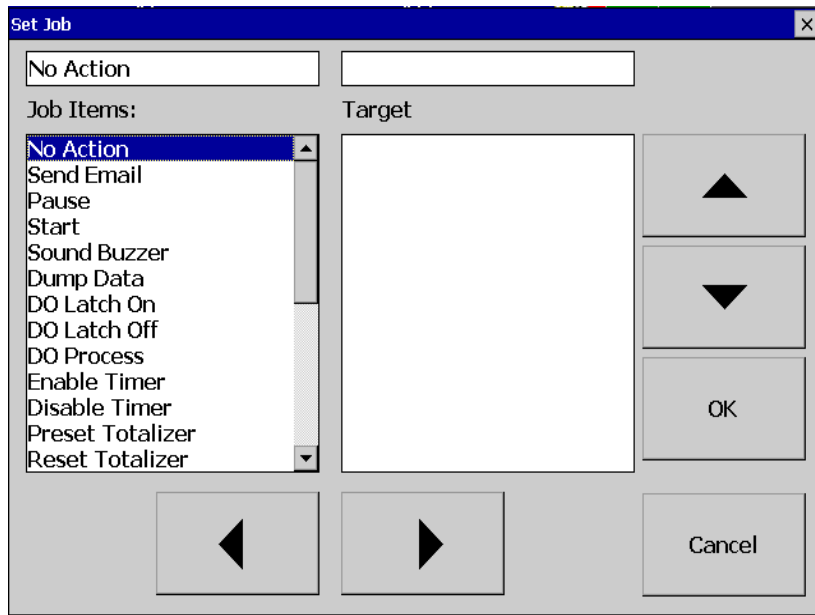

Sensor

- Type: Thermocouple K Type, °C
- Unit: °C
- Range: -200.0~1370.0

Type: Select the sensor input type for the Channel.

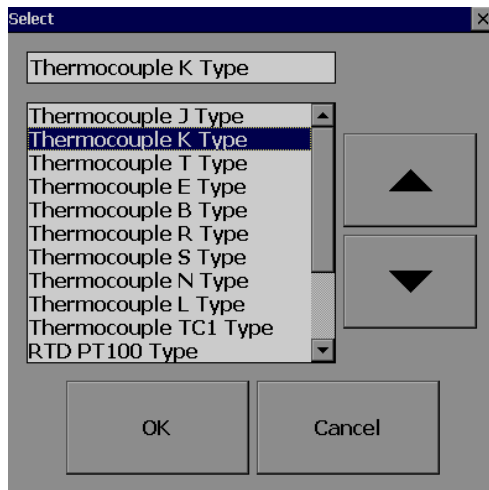

- RTD JPT100 Type
- RTD RTD1 Type
- Milli-Volts
- Volts
- Current

Unit: The engineering unit of input.

Range: Select based on Sensor type

Select

-200.0~1370.0

-200~1370

-200.0~1370.0

Sensor

Type: Milli-Volts

Unit: mV

Range: 0~1000

Select

0~1000

0~60

0~1000

-60~60

Sensor

Type: Volts

Unit: V

Range: 0~5

Select

0~5

0~10

0~5

1~5

-2~2

-20~20

Sensor

Type: Current

Unit: mA

Range: 4~20

Select

4~20

0~20

4~20

-20~20

Scale: Appears only for linear inputs Ex: mV, Voltage, current etc.

```
Scale
Unit: °C
Low: -120.0
High: 1000.0
```

Offset: It is offset value to correct the sensor error.

Gain: It is a multiplier to correct the sensor error.
The correct value = (the process value x gain) + offset

Events

Events are frequently used for Alarm purposes. Events can also be used for digital outputs (DO), Timer, Totalizer, Counter or Report.

Maximum five events are possible to set for each Analog Input
Press "Add" to add new event
Press "Remove" to remove selected event

```
Events
Add
Remove
1
Type: H
SetPoint: 776.0
Log: Log Alarm
Job1: No Action
Job2: No Action
Hysteresis: 0.0
```

Type: There are various types of H, L, HH, LL, Dev+, Dev-, and Error to be selected for a job or Alarm purpose

H: High limit. When the process is over high limit, the alarm or job is actuated.

L: Low limit. Any the process is lower than low limit, the alarm or job is actuated

HH: High high limit, to set up another limit higher than high limit for double warning.

LL: Low low limit, to set up another limit lower than low limit for double warning.

Dev+: Trigger event on positive deviation of process value. The job or alarm is activated when process value is deviated by greater than the setpoint + the process value.

For example:

Set point = 10

At 10.00.01 Hrs, Tag1 = 40

At 10.00.02 Hrs, Tag1 = 51

Then, job or alarm is activated

Dev-: Trigger event on negative deviation of process value. The job or alarm is activated when the process value is deviated by less than the set point-the process value.

For ex: Set point = 10

At 10.00.01 Hrs, Tag1 = 40

At 10.00.02 Hrs, Tag1 = 29

Then, job or alarm is activated.

Error: On channel error, an alarm or job is activated

Setpoint: To set up the process value for actuating Job1 and /or Job2

Alarm

Log Alarm: Record alarms

Log Alarm (Auto Ack): Record alarms and acknowledge automatically

Log Event: Record events

Job1, Job2: When an event occurs, the task to be performed is called the job. A typical example is to trigger **an alarm buzzer** in the event of a high temperature. Each pen can accept five different types of events (or alarms) and each event can create two jobs. Please note that a job under Event is different from a job created by pressing the **Operate** key. The former is actuated by an event, and the latter is actuated by manual control, no event necessary.

Note: *Please refer to the section "Jobs" for full details about various jobs available*

Hysteresis: To avoid it been activated too often, the Log Alarm or relay can set for no reaction. Hysteresis value can be defined for the event trigger set point.

Holding time here refers to, suppose the set point is reached, but you want to wait for some time to activate that action. This time is holding time. In process sometimes SP is reached but it will go down immediately, that might due to process instability. To counter this, we have given a holding time, to see that PV stays at above that SP more than the holding time and then we activate action for that event

Example 1

If the temperature is increased to more than 120°C, log alarm and switch on digital output 1. When the temperature is decreased to less than 80°C, log the alarm and switch off the digital output1.

Setting of events for the analog input in the channel configuration is as follows.

Events

- Add
- Remove

<ul style="list-style-type: none"> 1 — Type: H — SetPoint: 120.0 — Log: Log Alarm — Job1: DO Latch On_DO1 — Job2: No Action — Hysteresis: 0.0 	<ul style="list-style-type: none"> 2 — Type: L — SetPoint: 80.0 — Log: Log Alarm — Job1: DO Latch Off_DO1 — Job2: No Action — Hysteresis: 0.0
--	--

3.1.2 Digital Input

Path:  (Menu)-Config-DI

After entering the Configuration mode, in the Channel, select DI then press the “Enter” soft button to get into Digital Input Channel configuration page.

DI

1	2	3	4	
---	---	---	---	--

- Name: DI1
- Desc: Tank level high
- Type: Logic Level
- Events
- Add
- Remove

Name: Define the name for the Digital Input Channel. A maximum of 18 characters is allowed for the name.

Description: Define detail description for the channel.

Type: Logic Level

Logic Level: This selection activates digital logic, which is either one or zero with low frequency which is less than 1Hz, such as an external relay.

Pulse Counter: With this selection, we can feed high speed inputs (high Frequency, up to 100Hz)

Select Logic Level and press “Enter” key

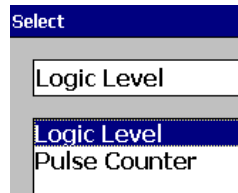

Events: A maximum of 2 events are supported for every digital Input channel.

A maximum of two jobs can be configured for each event.

**Note: Events will not appear if Logic Level selected as Pulse Counter*

Add: Press “Add” to add events to the Digital Input

Remove: Press “Remove” to remove events from the Digital Input

Type: Select Low, L or High, H

Job1, Job2: To configure a Job, select Job1, the press the Enter button. It will show a list of all the available jobs. Select the required Job.

Note: Number of digital inputs shown on the DI screen depends on number of Digital input cards inserted in the paperless recorder.

Sample applications of Digital input

After pressing a “Start” switch, latch ON Digital Output1

After pressing a “Pause” switch, latch Off Digital Output1

Start Timer, Stop Timer

Reset Totalizer, Reset Counter

Reset MaxMinAve values of all the channels etc..

It is possible to display Digital input status via status bar on any page in the paperless recorder. If digital input is not enabled, it shows as “Low”. Presence of an enabled digital input shall be shown as “High”. See the picture below.

To configure status bar, refer section “Display”

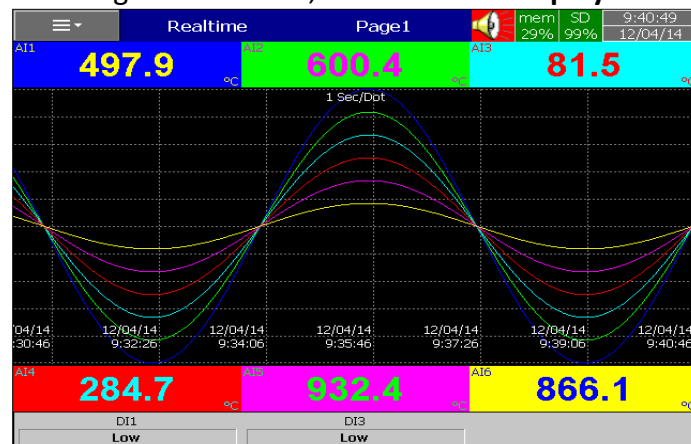

Status Bar and Digital Input Status

Digital Input status can also be monitored from the  (Menu). Press “Status” and then select “DI”, it will show the Digital Input Status as follows.

Menu		Status			DI	mem 84%	12:49:57
DI	DO	AO	Counter	Totalizer			
No	Name		Value	Desc			
1	DI1		Hi	Tank1 Level switch high			
2	DI2		Low	Tank2 Level Switch High			

3.1.3 Math Channel

Maximum no. of Math channels in various PPS series Recorders are as follows

PR Recorder	PR-10	PR-20	PR-30
Maximum Math Channels	15	40	60

Path:  (Menu) – More – Config - Math

After entering the Configuration mode, in Channel, select Math, then press the “Enter” soft button to get into Math Channel configuration page.

Math								
1	2	3	4	5	6	7	8	9
Name: Math1								
Desc: Math channel 1								
Type: Math								
Log								
DataType: 4 Byte								
Value Range: -3.4E+38 ~ 3.4E+38								
Trigger: Enable								
Method: Instant								
Speed: 100ms/Dot								
Expression: (AI1+AI2)/2								
Scale								
Unit:								
Transformation: Disable								
Decimal: 1								
Range: -214748364.8 ~ 214748364.7								

Name: Define the name of the Math channel

Desc: Define the detail description for the channel name

Type: Specify either Math, Totalizer or Counter

Note: Based on selection at “Type”, configuration details will be changed. For ex: Type = Math has different configuration details compared with Type = Totalizer or Type = Counter

Log data type, Trigger, Method, Speed: Same as Analog Input

Press **Back** key and then press “Home” soft button go to Real time display and memorize the Math settings.

Enter Expression column, it appears Source, Operator and a keyboard.

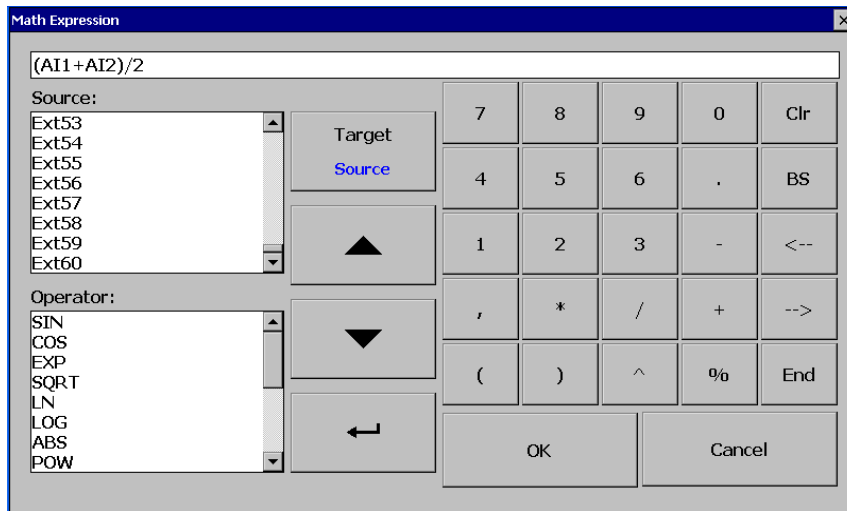

The Source covers all available Analog inputs, Digital Inputs, Math inputs, external channels.

The Operators are mathematical expressions described below.

Use Source, Operator and keyboard to define the Math equation.

- Scale
 - Unit: Tons
 - Transformation: Value
 - Table: Point 1 to 8
 - Range: 0 ~ 170

Transformation: Select disable, value or Math channel. This function mainly used to display process values obtained from Non-linearization table

Table: Select disable, value or Math channel

Maximum 64 rows can be entered in the Transformation table

Ex: A chemical tank has a non-linear shape. The level is 0 to 1400 cms. The Recorder should display 0 to 170 Tons as per following table

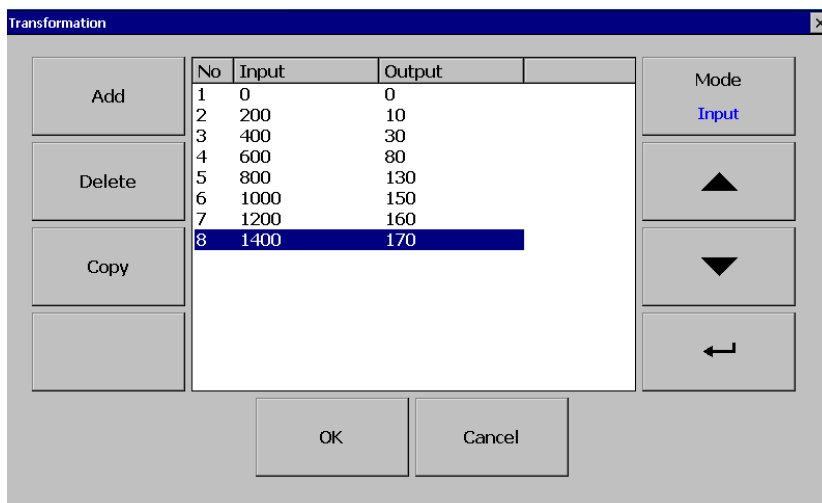

3.1.3.1 Counter

Path:  (Menu) – More - Config/Math

Select **Type = Counter**

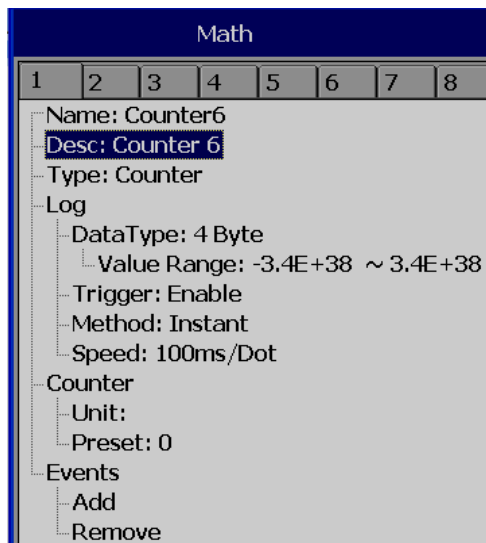

Press directional keys < > at the bottom to select one of the Math channels for the Counter operation.

Name: Defines the name of counter, max. 18 characters allowed

Desc: Defines the description for a specific counter on the display

Type: Select **Counter**

Counter

Unit: Defines the unit of counter

Preset: Defines the preset value for the counter

Event: Defines the type, Set point, Log, Job1 or Job2 & Hysteresis

Type: Select one of the options: H, L, HH, LL, Dev+, Dev-, Error

Set point: Defines the set point trigger of Counter value to initiate Jobs and/or Log alarms

Log: Select Log Alarm, Log Alarm (Auto Ack.), or Log Event

Job1, Job2: various jobs can be assigned, 2 jobs for each counter

Hysteresis: To avoid jobs have been activated too often, it can set for no reaction.

3.1.3.2 Totalizer

In our new generation Recorder, the Totalizer is a part of Math channels.

Configuration Path:  (Menu)-More-Config-Math

Select **Type = Totalizer**

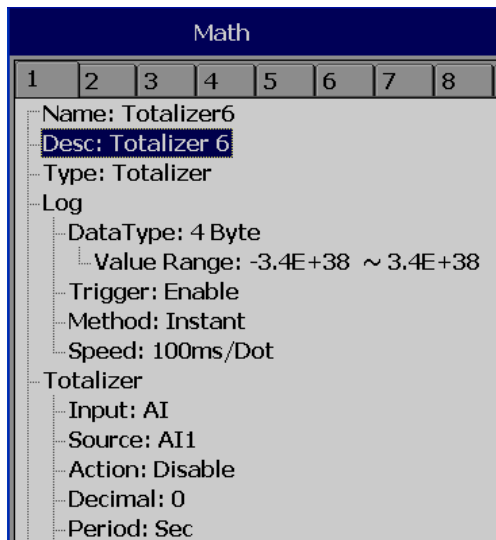

Press directional keys < > at the bottom to select from available Totalizers

Name: Defines the name of the Totalizer, Maximum 18 characters allowed

Desc: Defines the description for a specific Totalizer on the display

Type: Select "Totalizer"

Log: Same as Analog input configuration

Totalizer:

Input: Analog Input (AI) or Pulse Counter (DI)

Source: Select the source for the Totalizer from Analog
Input/Math/Counter/Totalizer

Action: Disables or enables the Totalizer

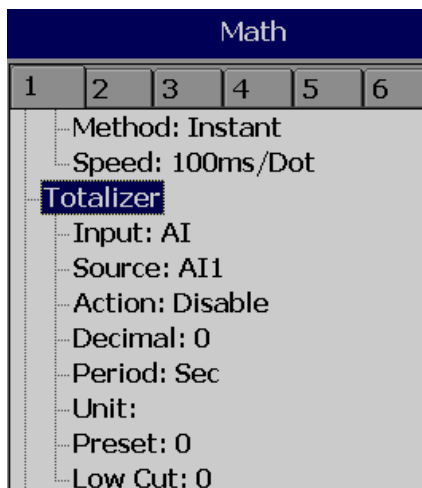

Decimal: Defines the decimal point for the Totalizer

Period: Selects if seconds, minutes or hours are used for the Totalizer

Unit: Defines the unit of totalizing

Preset: Defines the preset value for the Totalizer.

Low Cut: Defines the Low Cut for the Totalizer.

For ex: If 0.0 is set as Low cut, then, if source channel AI1 is less than 0.0, the Totalizer value will not go to negative.

- Event:** Total 5 events are supported for each Math channel. Defines the type, Set point, Log, Job1 or Job2 & Hysteresis
- Type:** Select one of options, H, L, HH, LL, Dev+, Dev-, Error
- Set point:** Defines the set point trigger of Totalizer value to initiate Jobs and/or Log alarms
- Log:** User can select one of Log Alarm, Log Alarm (Auto Ack.), or Log Event
- Job1, Job2:** various jobs can be configured, 2 jobs for each Totalizer
- Hysteresis:** To avoid jobs from being activated too often, the hysteresis can set to avoid nuisance tripping. Hysteresis values can be defined for the event trigger set point.

3.1.4 Analog Output

First check the AO card setting, there are DIP switches on the card and default is SET to Voltage output. For ma Output, SET 1 to 5 (ON), and 6 to 8 (OFF). Below picture explains.

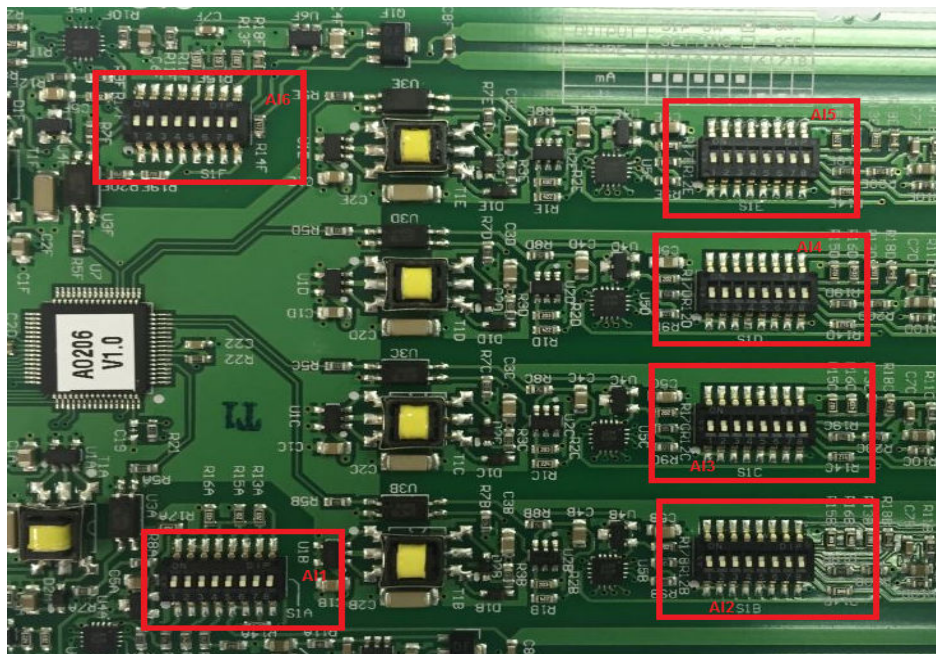

After entering the Configuration screen, in the Channel section, select AO, then Press the “**Enter**” soft button to get into Analog Output Channel configuration page.

Desc: Define detail description for the channel name

Type: Current, Voltage

Output: Select either disable, 0 to 20mA, 4-20mA, 0-5V, 1-5V, 0-10VDC

Expression: This is similar to Math channel.

4-20ma output: For Retransmitting of AI1 using 4-20ma output,

Expression: $4 + (20 - 4) * (AI1 - (-120)) / (1000 - (-120))$

Output Value =

$Min\ ma + [(Max\ ma - Min\ ma) * (AI1 - Min\ range\ of\ AI1)] / (Max\ range\ of\ AI1 - Min\ range\ of\ AI1)$

3.1.5 Digital Output

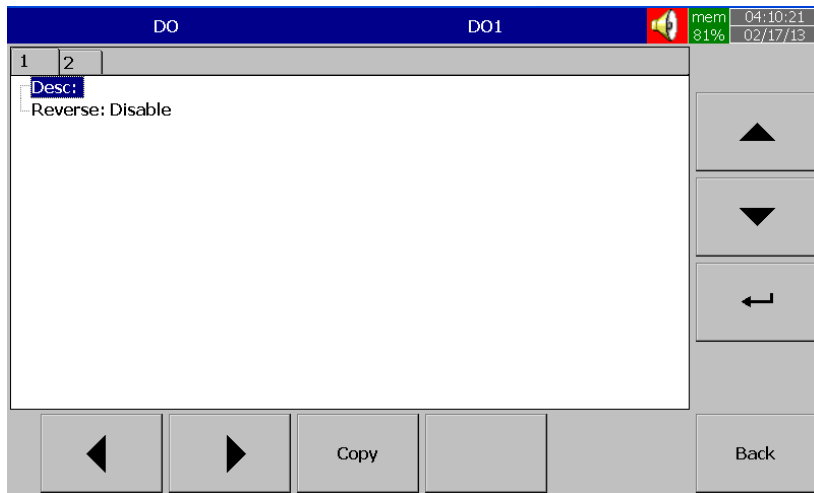

Desc: Define detail description for the channel name

Reverse: Enable this if Reverse operation is required for the Digital Output.

For ex: If reverse is disabled, the relay output is Normally Open (NO). In case if you need to have a Normally Closed (NC) relay at Recorder Power ON, then enable “Reverse” for the selected Digital Output. The Relay output shall be normally closed.

3.1.6 External

This is to access data from the external devices.

Maximum no. of external channels in various PPS series Recorders are as follows:

PR Recorder	PR-10	PR-20	PR-30
Maximum External Channels	24	48	96

All the properties are similar to Analog Input channel.

More details about external channels are available at section “Communication”

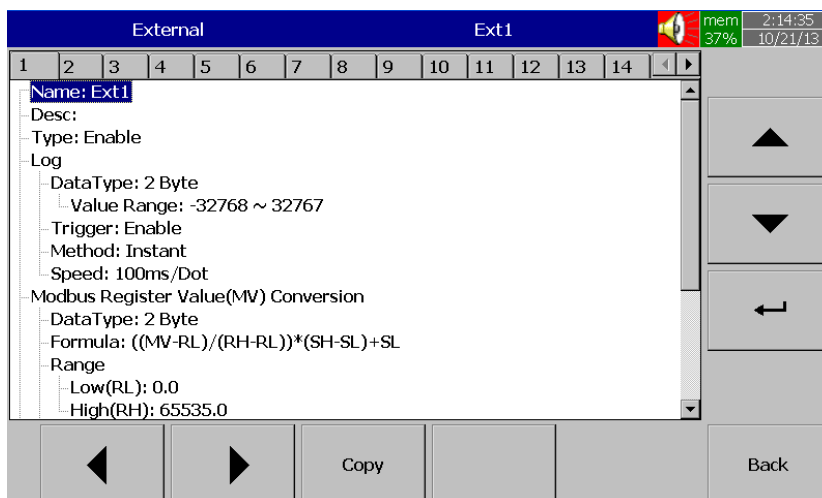

Please refer Detail Manual section “Communication” for examples of external channels.

3.1.7 Jobs

Various types of jobs can be selected as follows.

No Action: Do nothing

Send Email: Send Email directly from Recorder

Pause: Stop logging data.

Start: Start logging data.

Sound Buzzer: Sound the buzzer. It stops once any key is pressed.

Dump Data: To dump data from internal memory to external memory.

DO Latch On: Set digital output / relay on, and then select Target, let's say from one of DO 1 to DO 6. The relay is latched when it is activated.

DO Latch Off: Set digital output / relay off, and then select Target, let's say from one of DO 1 to DO 6. The relay is un-latched when it is activated.

DO Process: Set digital output / relay on for process high or low, and then select the target, let's say from 1 of DO 1 to DO 6. The relay is not going to be latched when it is activated.

Enable Timer: Start the timer, and then select Target timers

Disable Timer: Stop the timer, and then select Target from Timers

Preset Totalizer: set a preset value to the target Totalizer.

Reset Totalizer: Reset Totalizer to zero. Select a single target Totalizer or all totalizers

Enable Totalizer: Starts the Totalizer. Select a single target Totalizer or all totalizers

Disable Totalizer: Stops the Totalizer. Select a single target Totalizer or all Totalizers

Preset Counter: set a preset value to the target counter.

Reset Counter: Resets the counter to zero. Select a single target Counter or all Counters

Inc Counter: Increases the counter by 1. Select a target Counter or all Counters

Dec Counter: Decrease the counter by 1. Select a target Counter or all Counters

Log Report: Make a report for Counter, Totalizer, Analog inputs (Min/Max/Avg), Math (Min/Max/Avg), All Counters, All Totalizers, and All Channels (Min/Max/Avg). Choose this column, and the report will be presented as described in section "Reports".

Reset MinMaxAve: In the Report function, after logging the Min/Max/Avg data of AI and Math channels for one day for example, this will reset historical data in order to log new data for the next day. It is also possible to reset the Min/Max/Avg for "All Channels" at one step.

Print: If a printer is connected to the Paperless Recorder via the USB port or Ethernet, the following print jobs can be triggered from "events"

Print Historical data

Print Event List

Print Report List

Print Snapshot

The time period of Print depends on the configuration available at



(Menu)-More-Config-Auto-Output

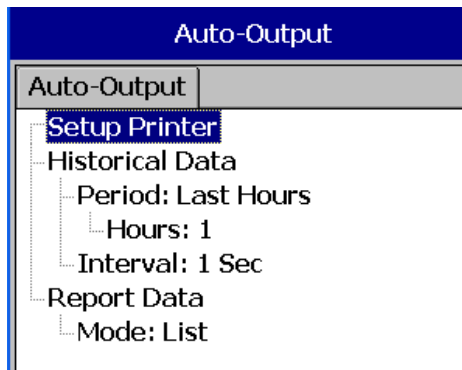

Note: Please refer section “Auto Output” for more details about options available

OutPut Historical Data: This action will generate a historical data output in the form of excel sheets on external storage. Output is in the form of .CSV files. It will contain also contain event reports.

Copy Value and Paste Value: This used for retransmission of Analog inputs using external (communication) Analog output channels. Since we have limitation of Analog outputs on the Recorder. This external channel can be utilized by using the copy value and paste value. You can do this by using event or timer when job1 is copy value, job 2 will be paste value.

Dump data: This action will dump the historical data on to the SD. this data format can be only read by our Historical viewer software. it is not in excel format as we had in Output historical data.

Note:

Press “Home” key to return to real-time display, all configurations will be memorized

◆ The Digital output DO card with relays can be set in Job1 and/or Job2. It can be viewed in “System Info” mode after it is installed into a Slot.

3.2 Display

Path:  (Menu) – More – Config - Display

Select “Display”, then press the “Enter” Soft button to get into the Display mode configuration page (shown on the following page).

	PPS-1000	PPS-2000	PPS-3000
Display pages	8	20	21
Pens/Page	6	6	10

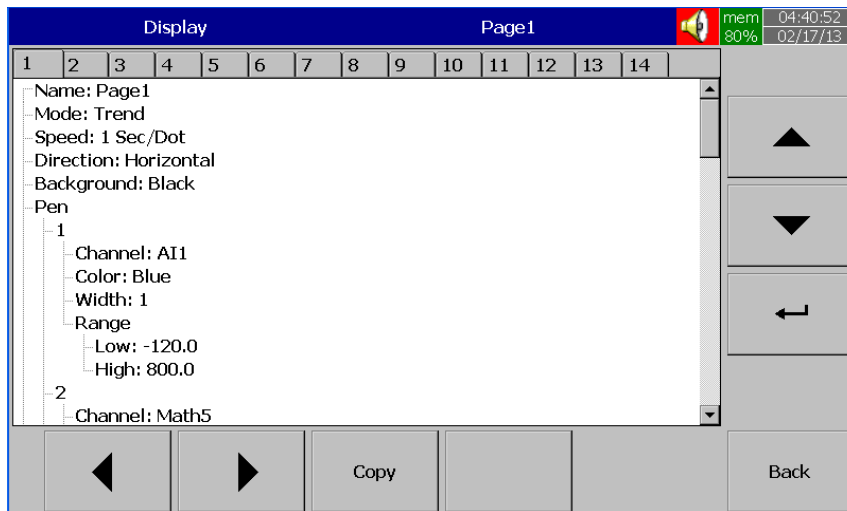

Name: Defines the name of the display page

Mode: Defines the default method of displaying data for the page.

Options are: Trend, Bar, Digital, Mix, Circular (only for PPS-3000) and Disable modes.

*** Circular Trends are only available in the PPS-3000 model.**

For Circular Trends

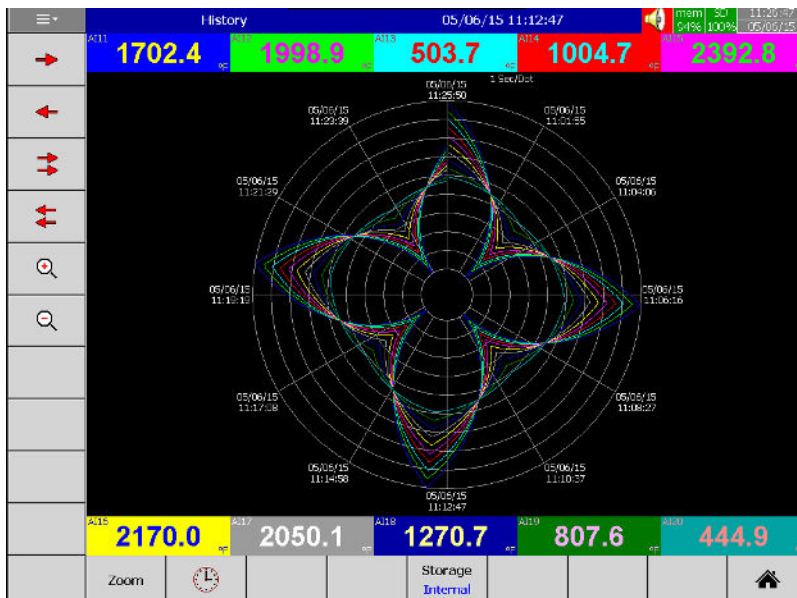

Speed: This is the display speed. Available options are 100 msec/dot, 1 Sec/dot, 2 Sec/dot, 5 Sec/dot, 10 Sec/dot, 20 Sec/dot, 30 Sec/dot, 1 min/dot, 5 min/dot, 10 min/Page, 30 min/Page, 1 hour/Page, 2 hour/Page, 4 hour/Page, 8 hour/Page, 12 hour/Page and 1 Day/Page.

Direction: Sets the trend direction to be horizontal or vertical.

Background: Sets the background color of Trend mode to black or white

Pen: For a specific channel, this defines the drawing pen, its color, width, Range Low and Range High for the display.

Channel: Selects a specific analog input, Math, Counter, Totalizer, External channels. Select Disable if a specific channel is not required to be displayed.

Color: Selects the color for each pen.

Width: Selects the width of trend, 1-thin, 2-medium, 3-wide.

Low: Defines the low scale for a pen on the display.

High: Defines the high scale for a pen on the display.

Note:

◆ To illustrate the difference between Display Hi, Display Lo, Scale Hi, and Scale Low, here is a typical example, with input 0-10V, Scale Low=0.00, Scale Hi=100.00, to have better resolution and vision on Bar, set the Display Lo=0.00 and Display Hi=50.00 so that the Bar displays from value 0.00 to 50.00.

◆ The decimal point is defined by Scale Hi and Scale Low, and not by Display Hi, or Display Lo.

3.2.1 Status Bar

Status Bar: To make it convenient when viewing the status of Digital Input, Digital Output, Math channel, Totalizer, Counter and AO, the user may enable these items in the status bar. The Status bar is displayed at Lower part of the page. A maximum of 10 tags can be displayed in each Status bar. One status bar can be configured for each page.

Note: Status bar configuration is not shared in all the pages. You may define a different setup for status bars in each page per your requirements.

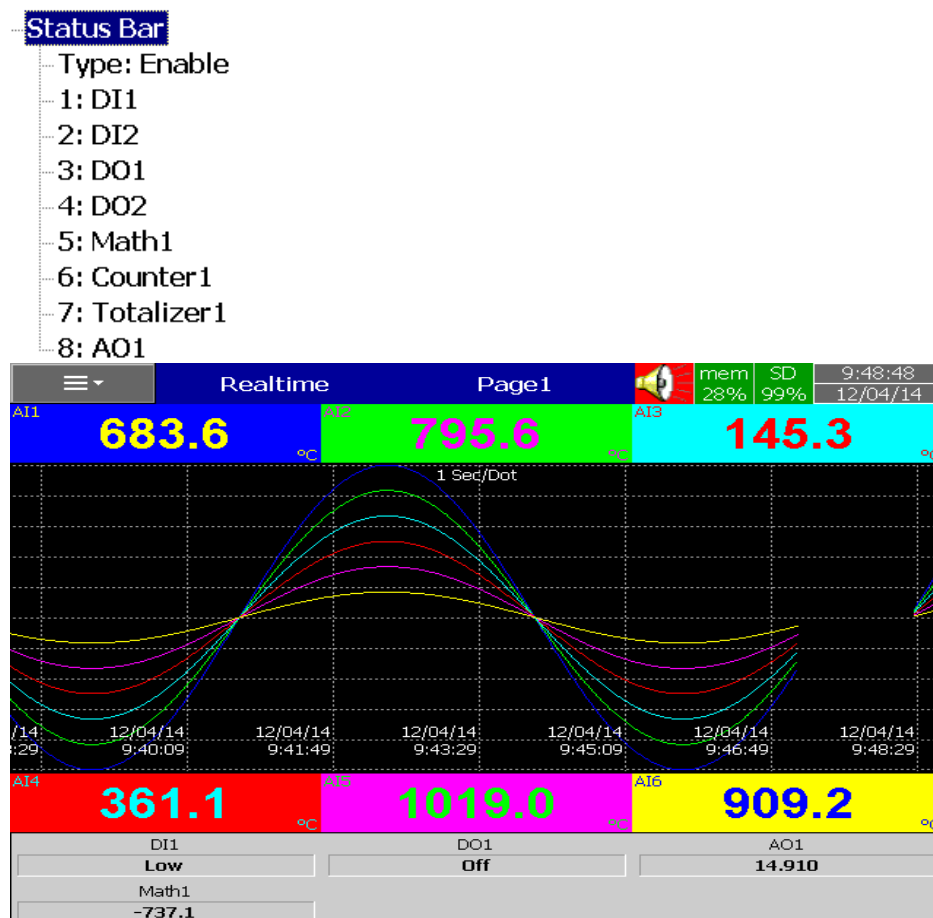

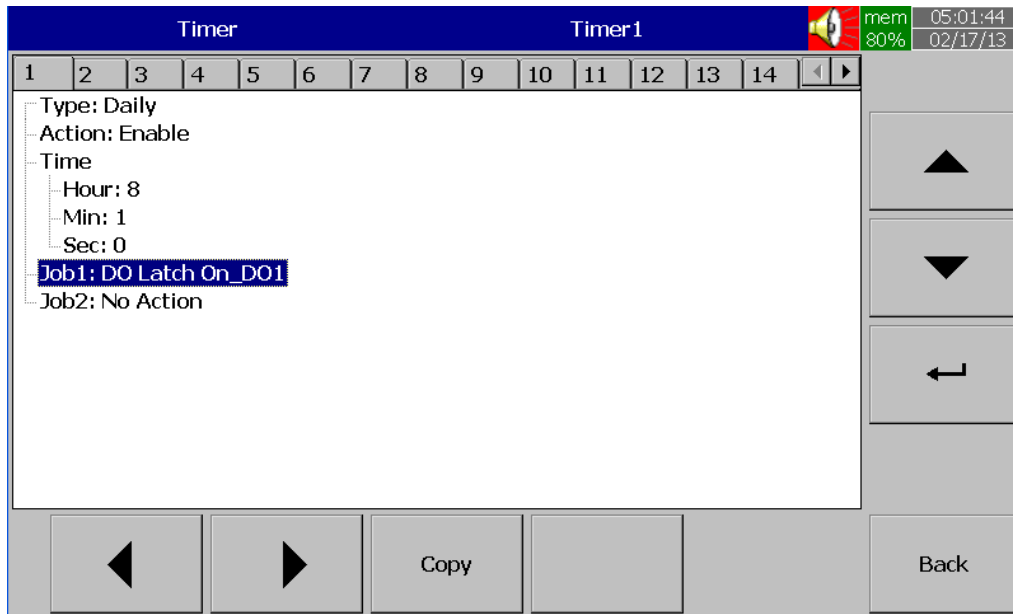

Fig: Status bar display in Real time

3.3 Timer

Path:  (Menu) – More – Config - Timer



Press directional keys < > at the bottom to select from one of 20 available timers

Type: Countdown, Repeat Countdown, Daily, Weekly or Monthly.

Countdown: Defines the interval of time, e.g. days, hours, minutes and seconds.
(Not the Actual Time)

Repeat Countdown: Repeats the previous countdown (Not the Actual Time)

Daily, Weekly or Monthly: The timer works in selected interval of Real Time.

Action: Disables or enables the timer.

Job1, Job2: 2 jobs can be configured for each timer.

3.4 Clock

Path:  (Menu) – More – Config - Clock



Fig: Clock configuration page in Paperless Recorder

Date Style: Selects either month/date/year or date/month/year

Date/Time: Set up the local time. Use directional keys Up/Down to select the column, press “Enter” soft button to change the clock data. Then press the “Apply Time” Soft button to apply it to the recorder.

Summer time: In some countries of North America and Europe, clocks are adjusted forward one hour near the start of spring and are adjusted backward in autumn. This is commonly referred to as Daylight Savings Time. We refer to this as “Summer Time”. A Summer time set provision is available in the paperless recorder. In **Summer time**, Select **Type:** Enable and then set Start (Month, Day, Hour, Min) and End (Month, Day, Hour, Min) details.

3.5 Communication

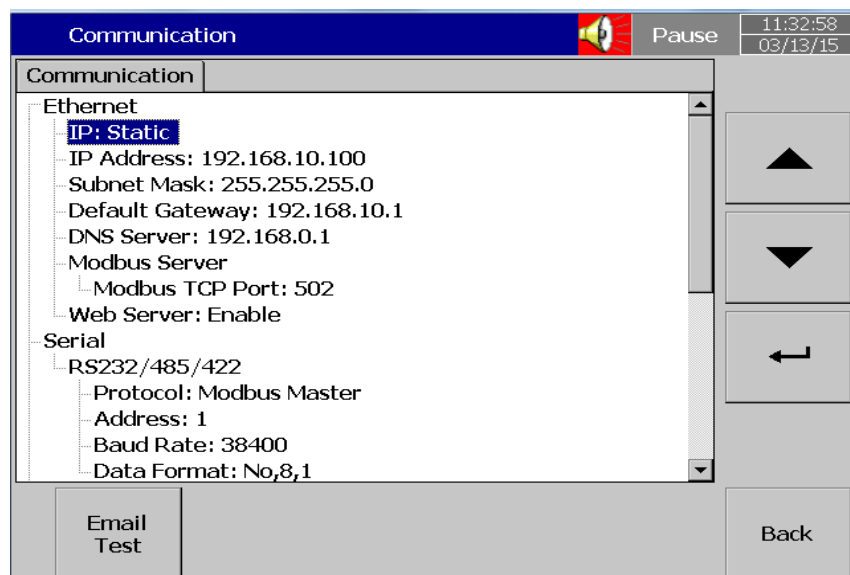

Ethernet

IP: DHCP/STATIC

Select **DHCP** if the server on the network automatically allocates the IP address for the recorder.

Select **STATIC** to manually set a fixed address for the recorder.

IP Address: Defines the current address of the recorder on the network

Subnet Mask: Defines the current **Subnet Mask** address on the network

Default Gateway: Defines the current Gateway address.

DNS Server: This is required if the recorder is to be connected to Internet

Modbus Server: When configured as Slave Recorder is act as Server in Modbus Connectivity

Modbus TCP Port: Default: 502 for Modbus TCP

Serial:

Protocol: Modbus RTU Master/ Modbus RTU Slave

Address: Address of Master/Slave in the network

Baud rate: 9600/14400/19200/38400/57600/115200

Data format: None, 8, 1 or Odd, 8, 1 or Even, 8, 1

Modbus Client/Master:

Sample Rate:

Ethernet: 100 msec/dot, 1 sec/dot, 2 sec/Dot, 5 sec/dot, 10 sec/dot

Timeout: The default timeout is 100ms

Serial: 100 msec/dot, 1 sec/dot, 2 sec/Dot, 5 sec/dot, 10 sec/dot

Timeout: The default timeout is 100ms

Interval between 2 commands: The default timeout is 10ms

Email: Enable/Disable

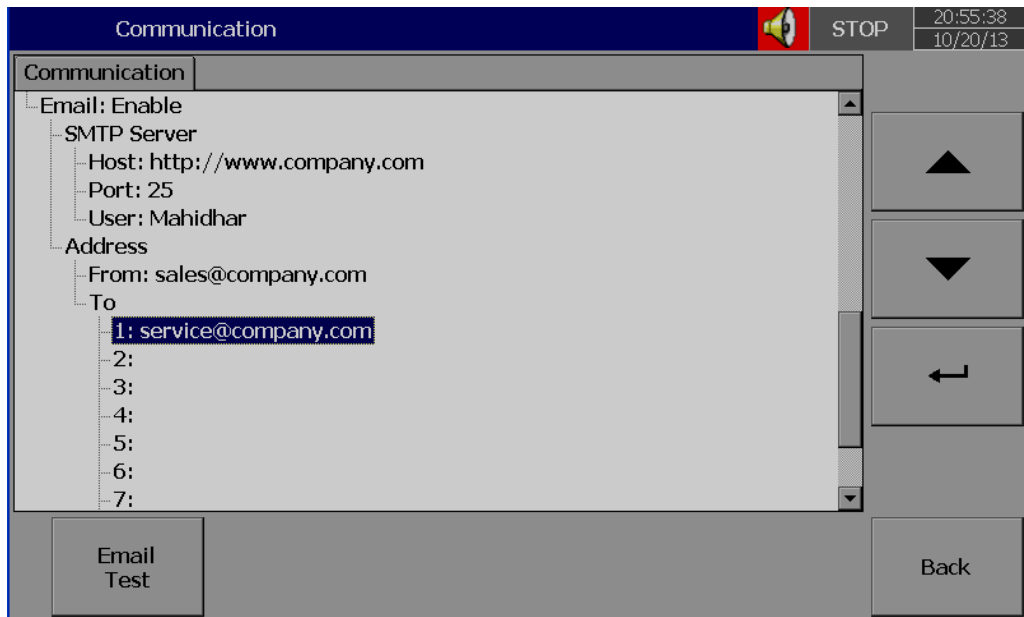

Press "Email Test" and check mail function

If any problems with Email delivery, it will show error as shown attached

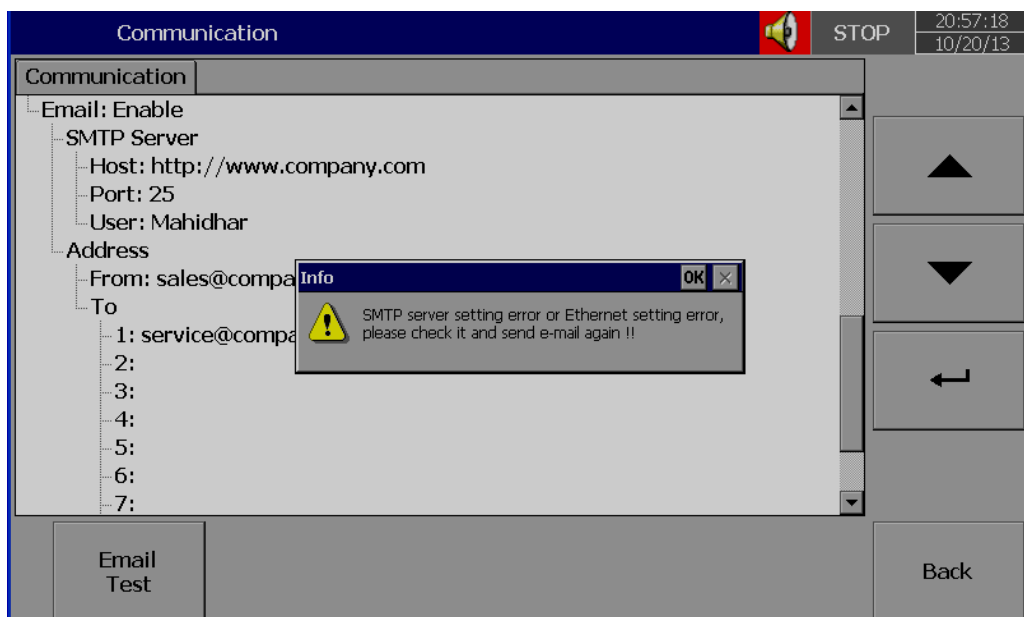

3.5.1 Connections

There is a total of 16 connections available

Each connection can be configured as either Serial or Ethernet

Connections					
1	2	3	4	5	6
Name: Connect1 Type: Serial Slave ID: 1					

Name: Connection name

Type: Serial/Ethernet

Slave ID: If Recorder is Modbus RTU Master, then, all the Slaves need to be configured in the connections.

Connections				
1	2	3	4	5
Name: Connect2 Type: Ethernet IP: 192.168.0.1 Port: 502 Slave ID: 1				

IP: This is enabled only if Type = Ethernet selected at any connection.

3.5.2 Commands

A total of 16 commands are available

Commands					
1	2	3	4	5	6
Action: Disable Channel First: Ext1 Last: Ext1 Device Register Start Address: 1 Data Type: Int16 Connection: Connect1					

Action: Enable/Disable

To Channel:

First: Enter first external channel details, Ex: Ext1

Last: Enter last external channel details, Ex: Ext24

From Device

Register:

Start: Address: Enter Start register address

Data Type: Int16/UInt16/Int32_B/Int32_L, UInt32_B, UInt32_L, Float_B, float_L

Connection: Select the required connection

3.6 Instrument

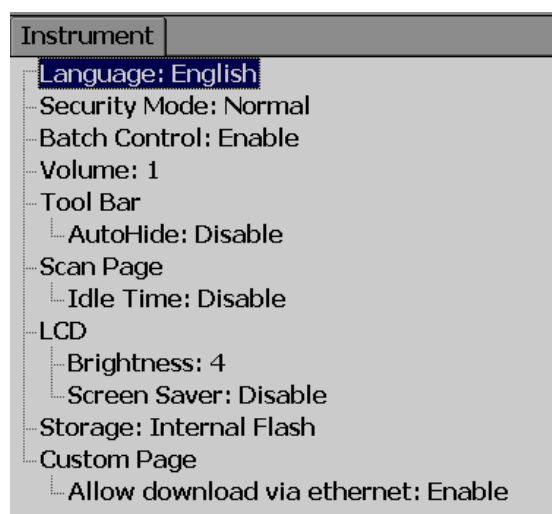

Language: A total of 19 languages are supported. They include English, Simplified Chinese, Traditional Chinese, Japanese, Korean, French, German, Italian, Polish, Spanish, Portuguese, Brazil Portuguese, Russian, Thai, Czech, Danish, Dutch, Swedish & Turkish

Security: Select Normal or CFR-21 security. More details available at section “Security”

Batch Control: Disable and Enable options available for the selection. Refer section “Batch Control” for more details.

Volume: When the screen is touched, you can hear a “beep” sound. Select Disable to switch off the beeper. Select value 1 to 10 for volume control. 1 is minimum sound and 10 for maximum sound

Tool bar: On left side of the display page, the tool bar appears for configuration.

Auto Hide: Select 10 Sec or 20 Sec or 30 Sec or 60 Sec to hide the tool bar if the user does not operate recorder via touch screen for the set time interval. Select “disable” if auto-hide is not required on specific set time

Scan Page: The User can set Automatic scanning of display pages for fixed time when enabled. The Fixed times are 1 minute to 10 minutes.

Idle time: If touch screen is not used for the set idle time, then the display pages will start scrolling as per defined scan rate. Select 1 to 10 Min. for the idle time if display scroll feature is required, otherwise select “disable”.

Scan Rate: This is the scroll time for the display pages. Select a time interval between 5 sec to 30 sec. This time interval is effective only if the “idle time” is enabled and the selected time is between 1 to 10 min

LCD Brightness: Select level between 0 and 6. 0 is the lowest brightness and 6 is for the highest possible brightness.

Screensaver: To prolong the life of the LCD display, it is suggested to set the display turn-off time to 1, 10, 20, 30, 40, 50 or 60 minutes after the last time the user operates the recorder. **Screensaver default time is set to 10 minutes from the factory.** The recorder continues to record data while it is in screen saving mode. The display turns on again by touching the LCD screen

Storage: Select internal flash memory or SD card

Custom page: User can use this setting to enable or disable custom pages downloaded via Ethernet.

Allow download via Ethernet: Enable/disable

3.7 Security

3.7.1 Normal

Path:  (Menu) – More – Config - select Instrument, then press “Enter”

Select “Security” = Normal

If normal security is selected, users will need to key in a common password with a maximum of 18 characters. Once the password has been entered, the user needs to key in the password whenever **Config, Dump, Clear** or **Operate** soft keys are required. These keys enable the user to do configuration, dump data, clear data or manually operate the job. For easy access **Config, Dump, Clear** or **Operate** soft keys, the user may ignore the password by leaving the password field blank. If a password is not entered initially, there is no password required.

How to enter simple password

 (Menu) – More - Config, select Password, press “Enter”, then key-in the password

3.7.2 CFR-21

If the higher security CFR-21 is selected, it requires the recorder to operate with more restricted rules which comply with **FDA 21 CFR Part 11**

It has time limit during operation. If the user does not press any keys in a predefined period of time (which can be selected between 1 to 20 minutes using LogOut function), the user needs to key in the password again. It also offers an audit trail function to record the user, the timing, and what type work the user was doing on the recorder. Incorrect password and unauthorized operation will be recorded into the event list as well. The maximum number of users available in FDA 21 CFR Part 11 Security Mode is 30.

In  (Menu) – More – Config - Select **Instrument**, press “Enter” soft button. Select Security = CFR-21.

```
Security Mode: CFR-21
-Logout: Disable
-Password validity: Unlimited
-Security Level of Functions
  -Login From PC: 9
  -Dump: 9
  -Clear: 9
  -Operate: 9
  -Config: 9
  -Pause: 9
  -ShutDown: 9
```

LogOut: Time selection available from 1 min. to 20 min. This selection is visible only if CFR-21 is selected.

If no user operates the Paperless Recorder for the above set duration, the current user will be logged out automatically

Password validity:

Password validity can be set for 30, 60 or 90 days. After the preset amount of days, it will require the user to key in a new password, or keep the old one for an additional 30, 60 or 90 days.

Security levels:

0 to 9 levels are supported

9 is the highest authority level, 0 is the lowest

3.8 Demo

The Demo mode is a simulation mode used as a sales tool for demonstration purposes. It is set to simulate AI analog inputs and Math functions.

*To start the automatic demonstration, first enable **Demo mode**, then turn the power OFF and Power ON to make it effective. To stop the automatic demonstration and return to real mode with real inputs, first disable Demo mode, then turn the power off and Power ON.*

3.9 Auto-Output

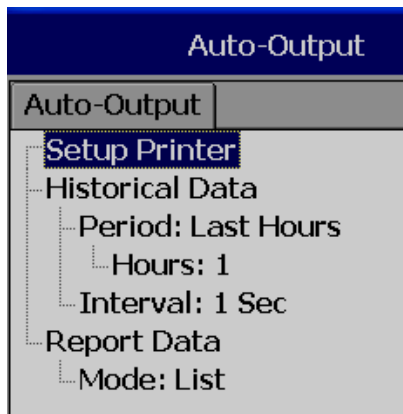

Setup Printer: It is to configure printer

Select **Setup Printer** and then press the “Enter” soft button

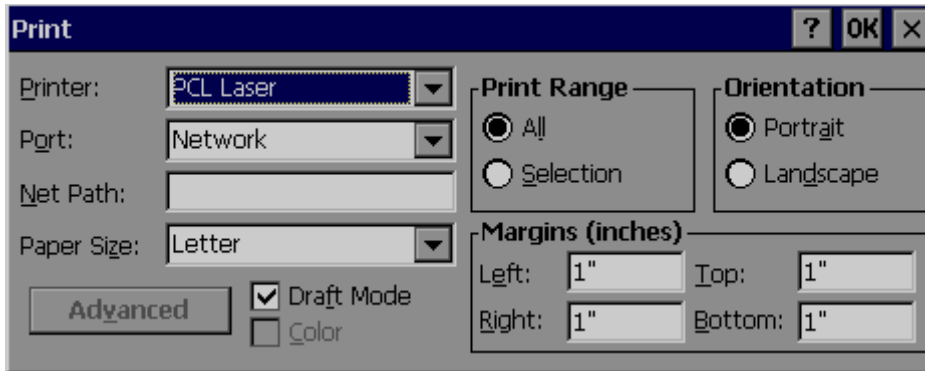

Two kinds of printers are supported. One is USB printer for page printing, and another is Serial printer for Line printing.

Applications: Print Historical data, events, & Reports and snapshot directly from Paperless Recorder.

3.9.1 USB Printer

Generally, USB printer support PCL protocol. It means, it will support Page Print, but not line print. We support PCL language 4, 5 & 6.

If USB printer supports ESCP protocol similar to EPSON LQ300+, then, it is possible to take line print.

Please refer Printer user manual for exact protocol details



Do not use USB printer supporting only PCL to print single line alarms, otherwise, pages will be wasted

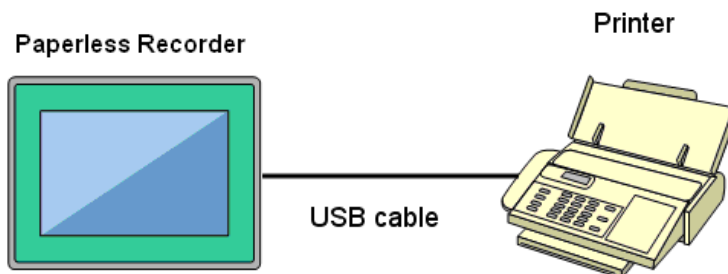

Procedure

Connect Recorder to Printer via USB cable

Power ON Printer

Path:  (Menu) – More – Config – Auto - Print, Enter
Select "Setup Printer", press "Enter" soft button

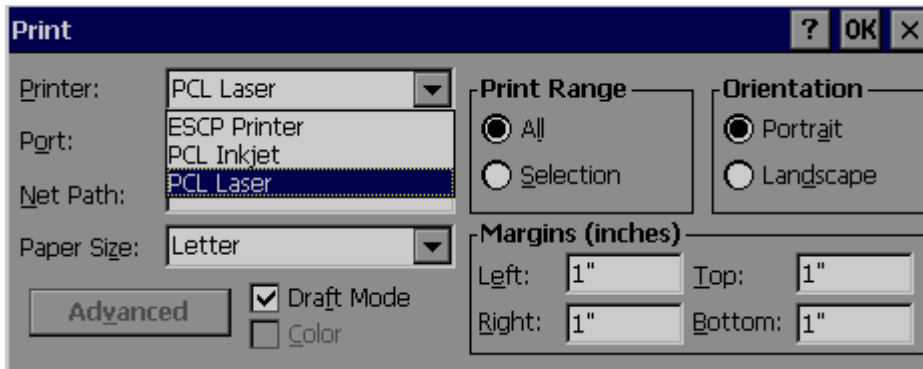
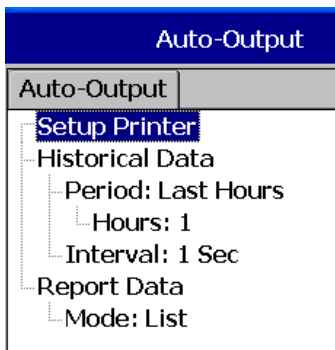

Printer: PCL Laser, ESCP printer, PCL Inkjet available by default. Select one from the list as per printer model connected to the Paperless Recorder

Port: It shows “Network” by default. Once a printer is connected to the USB port, it will show “LPT1” for the USB printer. Select “LPT1”

Net Path: It is required to enter the correct network path here only if both Printer and Paperless Recorder are connected to a LAN network

Paper Size: A4, B5, Legal and Letter are supported

Draft mode: By default, it is selected. If more quality print is required, deselect Draft Mode

Color: Enabled for Inkjet printer

Orientation: Select Portrait/Landscape as per requirements

Note: Margins & Print Range are not working at this time.

Now, setup is ready at Paperless Recorder

3.9.2 Network Printer (LPT1)

Serial printer will print minimum one line and is generally used for printing Real time alarms. Also, it can be used for printing historical data and alarms from the Paperless Recorder. ESCP language id supported, so any printer supporting ESCP like LQ300+ can be used. The LPT1 port of a PC can be connected to a Serial printer directly. However, it needs to have a Printer driver installed in PC first and share it for network use via Ethernet.

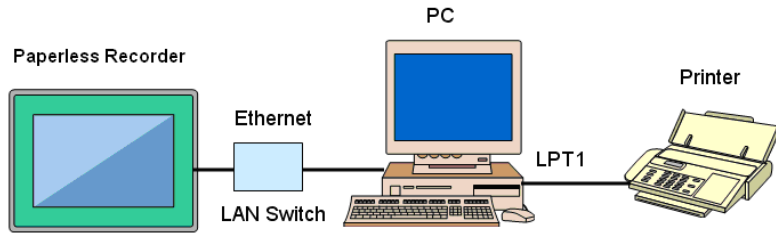

Procedure

Connect Paperless Recorder to PC via Ethernet

Install Printer driver in PC. Share Printer for network use

Connect Printer to PC via LPT1

Power ON Printer

In Paperless Recorder, at Path, select  (Menu) – More – Config – Auto - Print, Enter

Select “Setup Printer”, press “Enter” soft button

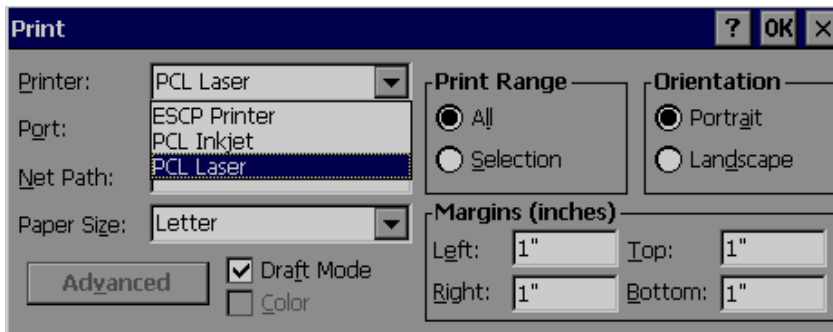
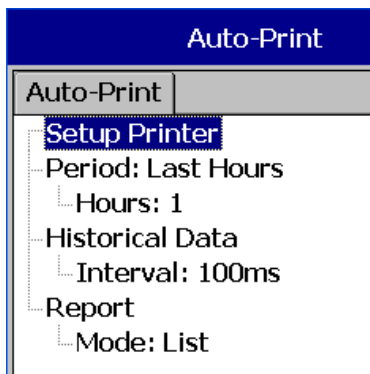

Select ESCP printer.

Then, enter the proper Net Path. Ex: \\PC1\LQ300

PC1 is computer name and LQ300 is shared printer driver for network use

Now, the setup is ready at the Paperless Recorder

3.9.3 Print Historical data

Configure USB Printer or Network printer as explained in earlier section

In Paperless Recorder, at Path, select  (Menu) -More-Config-Auto-Output, Enter

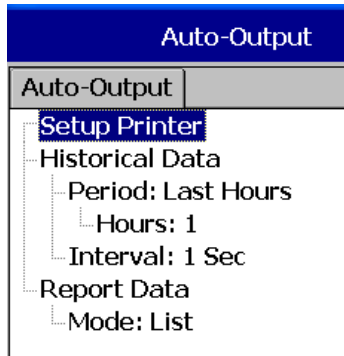

Period: Select Last hours or Last days

Hours/Days: Select no. of hours or no. of days as per above selection

Interval: Select intervals of 100 msec/1 sec/2 sec/5 sec/10 sec/20 sec/30 sec/1 min/5 min/10 min.

The Print function is available in the Job list and can be initiated in various ways.

Ex: Print historical data of last 1 hr. and do this every day at 8.00 hrs

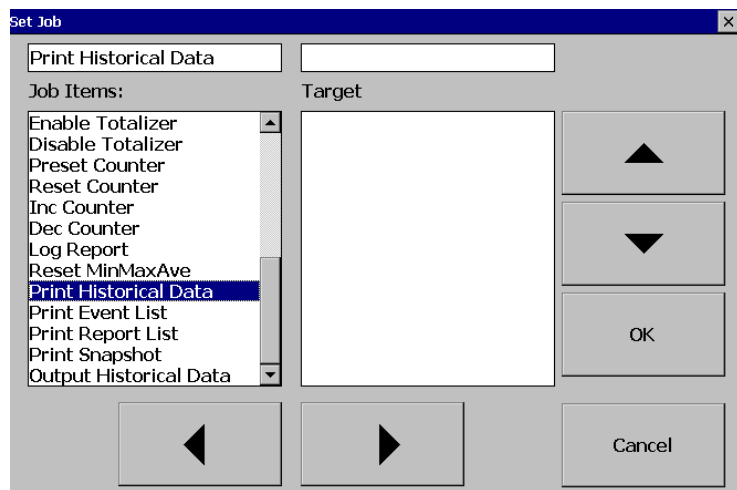
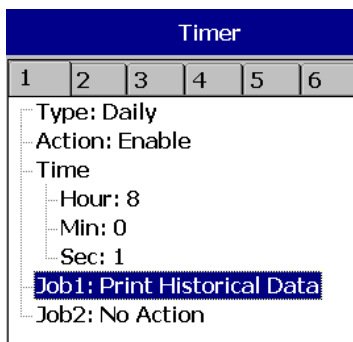

3.9.4 Print Reports

In Paperless Recorder, at Path, select  (Menu) - More- Config – Auto - Output, Enter

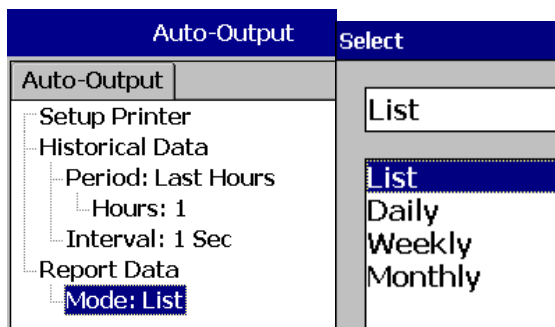

In the **Mode**, select which kind of Reports are required. Available options include Daily Reports, Weekly Reports and Monthly Reports

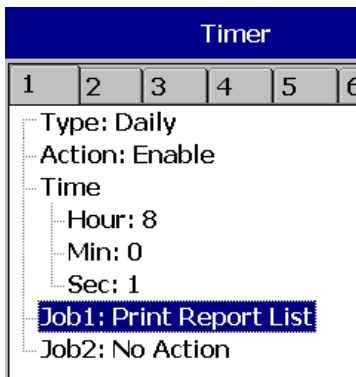

3.9.5 Print Snapshot

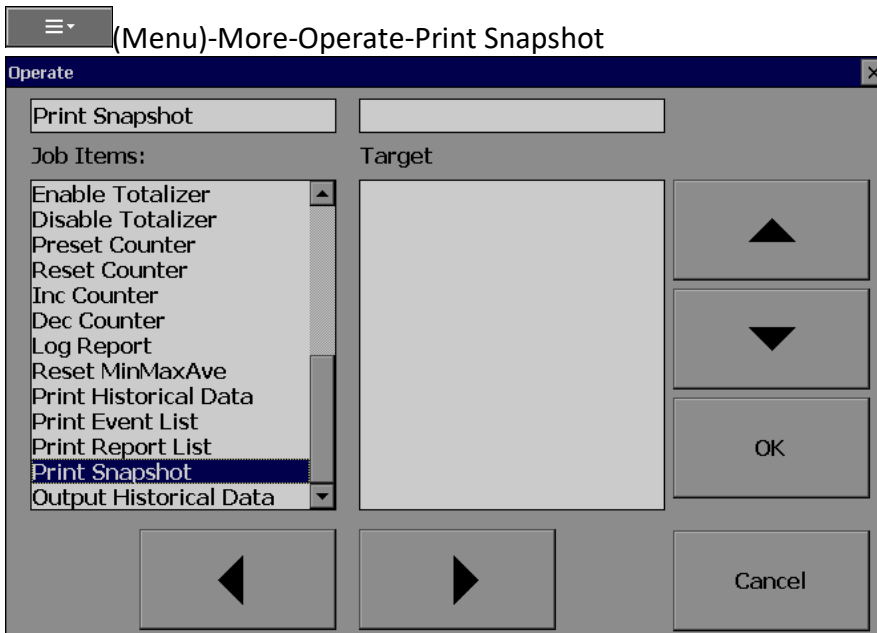

3.10 System Info

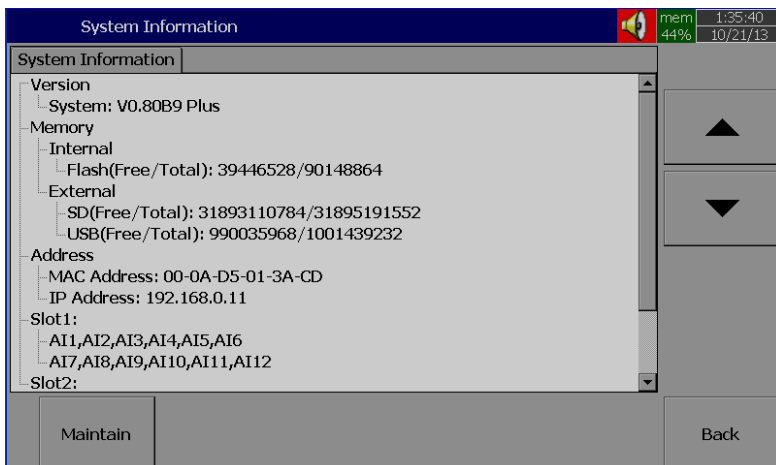

Path: (Menu) – More – Config - System Information

The system information includes System version, Internal and External memory, Ethernet IP address and Slots status

Version: The firmware version of the recorder.

Memory (Free / Total):

Internal: Indicates the percentage of free memory compared to total memory available in internal flash card

External: Indicates the percentage of free memory compared to total memory available in external memory devices of SD and USB.

A small icon on the top right indicates the percentage of free memory e.g.: Mem 96%

Address:

MAC: Displays the MAC address of Paperless Recorder

IP address: Displays the IP address for the Paperless Recorder

Slot 1.5: Indicates the status of all Slots and the cards that have been inserted. The cards include Analog Input AI, Digital Input DI and Digital Output DO & AO.

3.10.1.1 Upgrade Firmware

Path:  (Menu) – More – Config - System Information - Maintain

Maintain: The Maintain button is located at left lower side in System Info. page. It is the button to upgrade the firmware and calibrate the touch screen in the paperless recorder

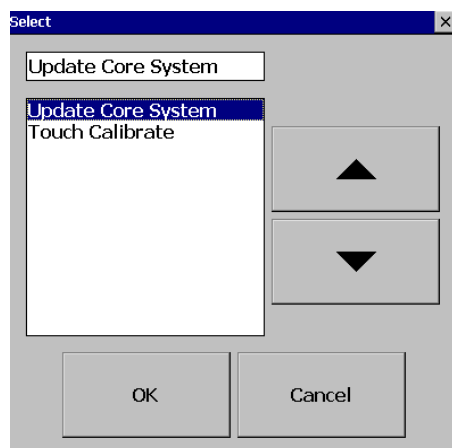

Upgrade Core System:

This is to upgrade firmware in the paperless recorder. Contact factory/supplier for the latest firmware files. Please download firmware file to a USB stick or SD Card then, insert the USB stick into USB port or SD Card at SD card Slot in the Paperless Recorder. Select the External Storage to SD Card or USB flash on the External Storage Setting depends on the storage inserted. Select “Update Core System”, then click the “OK” button. It may take a few seconds to finish the process. Please note that the power to the recorder should be not switched off during this upgrade process

3.10.1.2 Calibrate Touch Screen

Path:  (Menu) – More – Config - System Information - Maintain

Maintain: The Maintain button is located at left lower side in System Info. page. It is the button to upgrade the firmware and Calibrate touch screen in paperless recorder

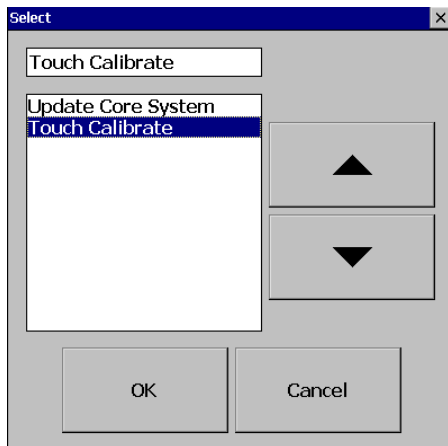

This is used to calibrate the touch screen. A “+” symbol appears in the center of the LCD screen. Carefully press and briefly hold a stylus or finger on the center of the target. Repeat this procedure as the target moves around the screen. Just touch the screen to complete the screen calibration. This procedure helps to locate pointer via touch screen and properly select the objects during operation of the recorder

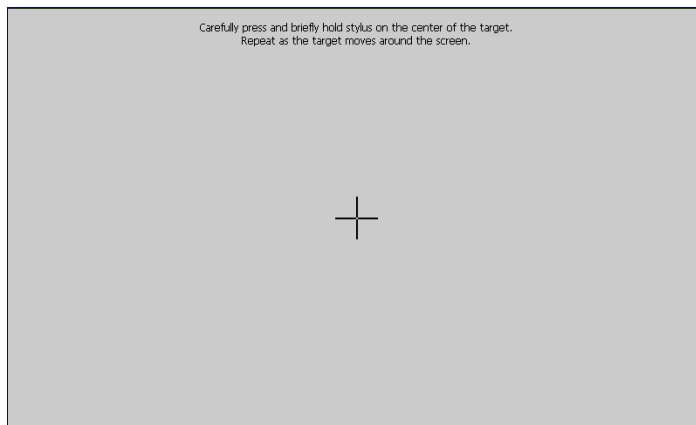

3.11 Batch Control

This feature is to store data in a different folder for every batch and archive data later with reference to a batch.

Path:  (Menu) – More – Config - Instrument

Select Batch Control and press “Enter” key. Select “Enable”. Press “Ok”

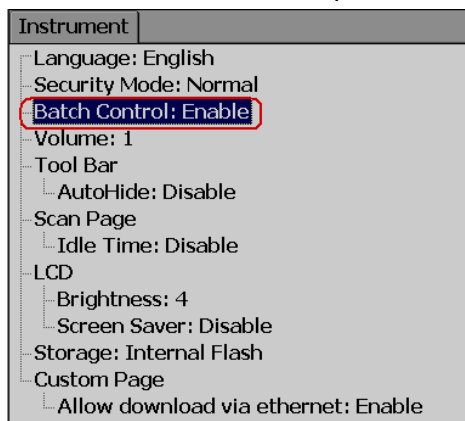

Press "Back"



Press "OK", then, press "Home" Soft key to save these settings

Power the recorder OFF then ON, then in the  (Menu), the Batch soft key will be shown as below

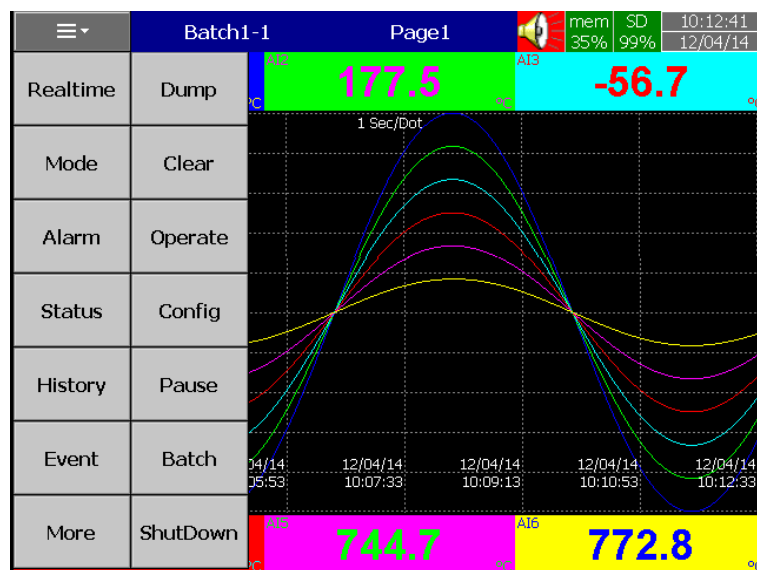

Note: "Batch" soft key will appear only after Batch Control enabled as explained above

Press on Batch and it shows the following screen

Set Batch

Batch Name - No:
 -

Comments:
 1:
 2:
 3:

OK Cancel

Operator can enter a maximum of three comments for any batch.

In the  (Menu) – More - Config, select “Batch”, press “Enter” key
It will show the Batch control settings as shown below

Batch
Name: Batch1
Lot Number: 1
Auto Increment: Enable
Jobs
Start: No Action
Stop: No Action

Name: Enter Batch name. A maximum of 18 characters is allowed. By default, the name is Batch1.

Lot Number: Enter the Lot number. If Auto increment is enabled, then Lot numbers will be incremented automatically by the recorder, Batch1-1, Batch1-2, Batch1-3 etc. during every start of a new batch

Jobs: Two events, Start, Stop are available

Start: Start means Jobs that should be done during start of a new batch

Stop: Stop means Jobs that should be done during stop of a batch

Note: When batch control is enabled, the recorder will be in Pause mode by default initially and it requires Starting of the recorder from the Menu by pressing at  (Menu) - More than “Start”. When recorder is not logging any data, Pause status shall be shown in the Top right area of the recorder as shown below



How to do the batch control

Press on  (“Menu”), “More”, then “Start”. Batch number will be shown in the recorder Top area.

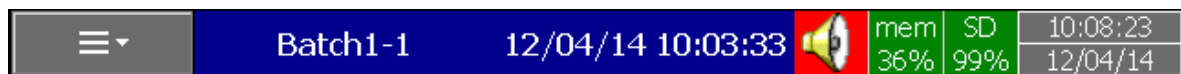

To Stop this batch, press on “Menu”, “More”, then “Pause”. It gives a message “Saving data” and updates batch data in the internal memory of the paperless recorder.

3.12 Calibrate

This function is used for calibrating Individual Analog channel.

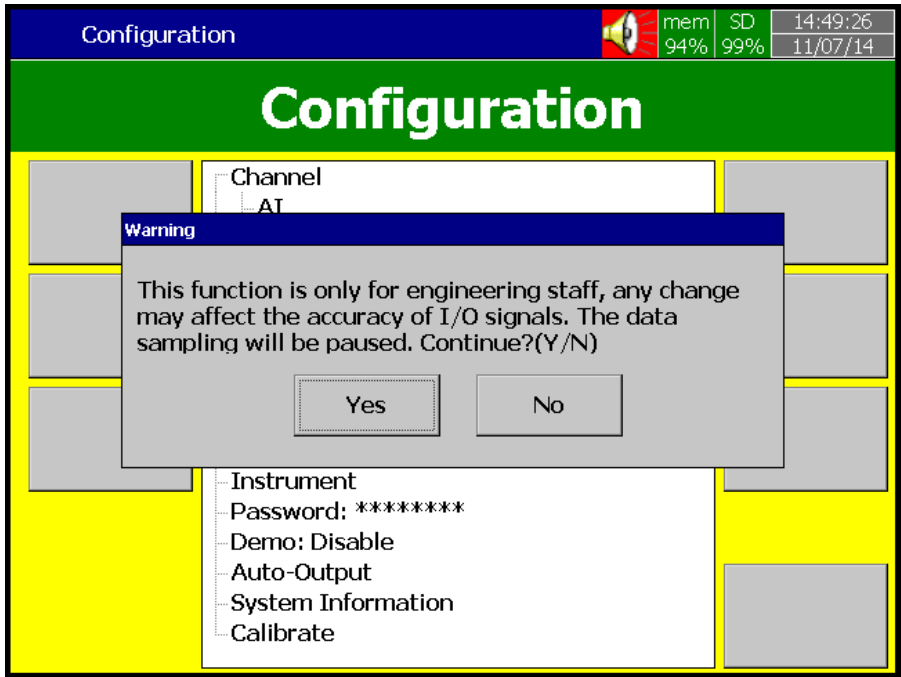

Example 1:

Calibrate an AI with 0-5V

When you click Calibrate menu, the user can see the below screen. Please click calibrate as shown in the below screen

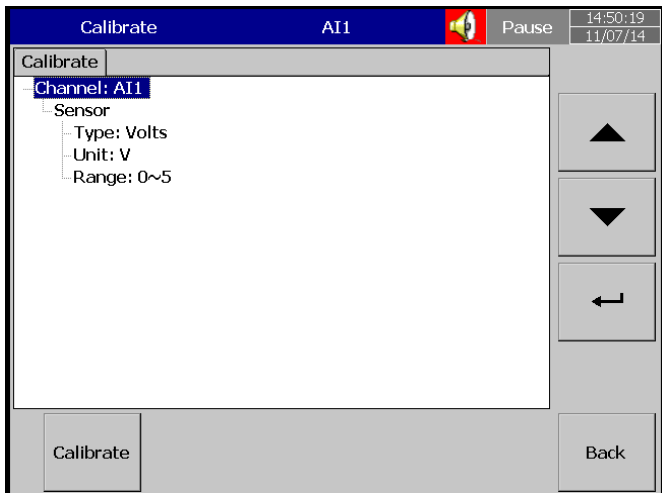

Please note that, in order to calibrate the whole Module slot accurately, the 3rd channel of each slot must be calibrated first. Click OK.

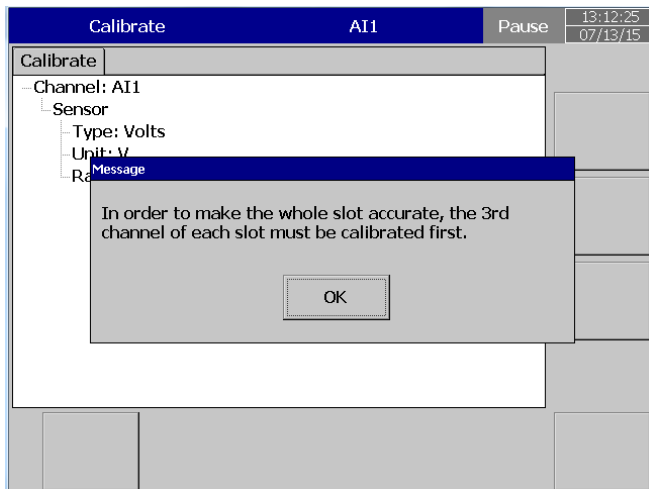

Now click Calibrate button as shown below.

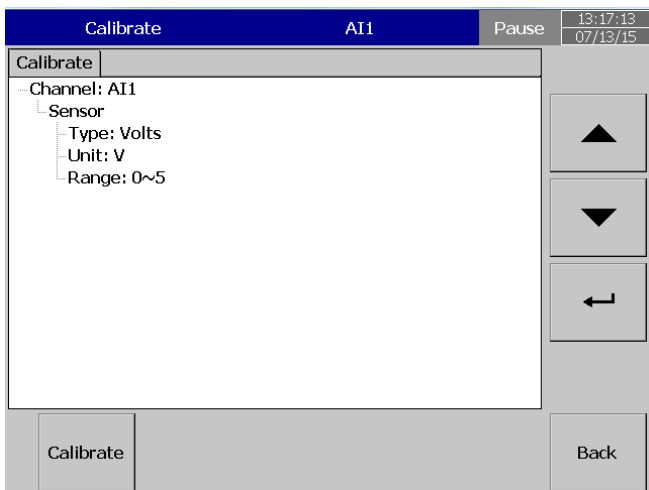

Click yes and proceed with the calibration process

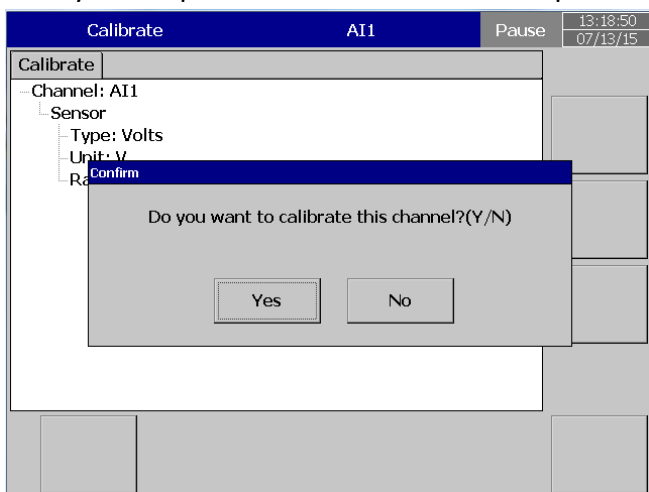

Please follow the next instruction, input 0V in to the input which can be seen in below screen

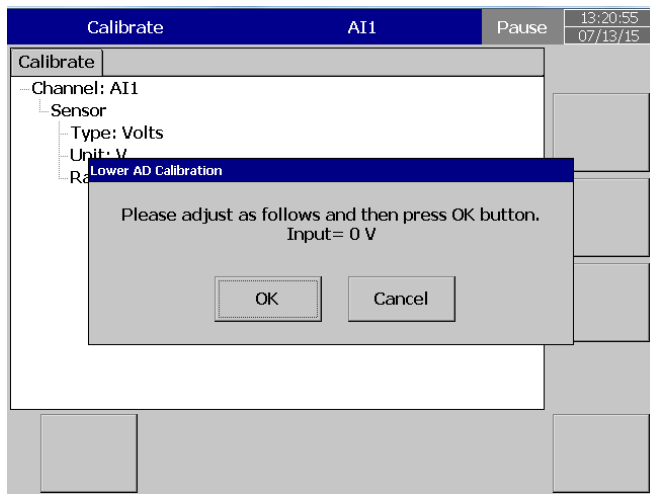

After you input 0V and select OK, the user can see the below screen. Now follow the next instruction.

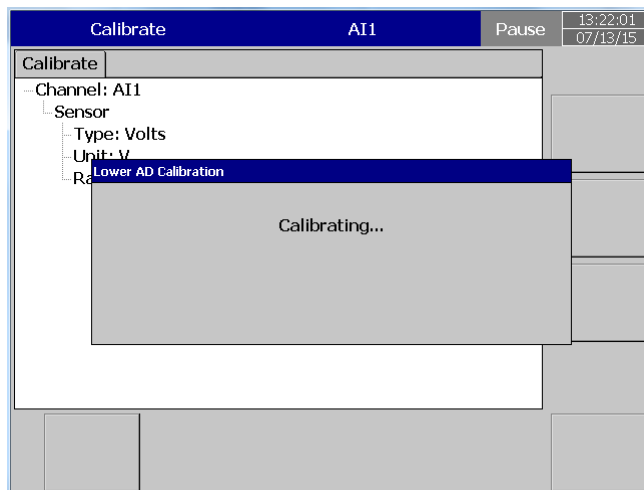

Now input 5V and click OK

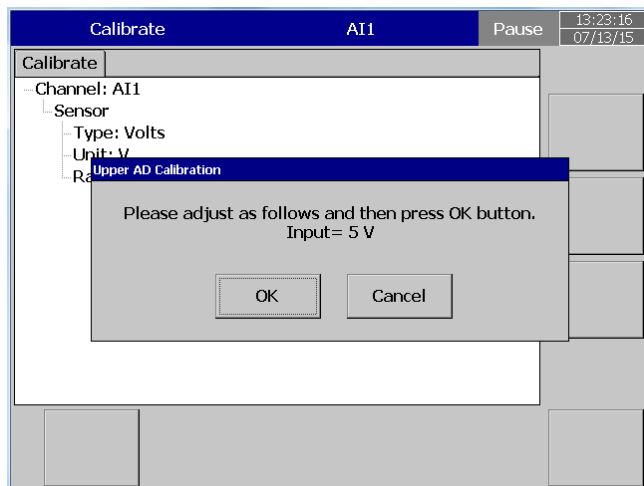

After you input 5V and select OK, the user can see the below screen
Now follow the next instruction.

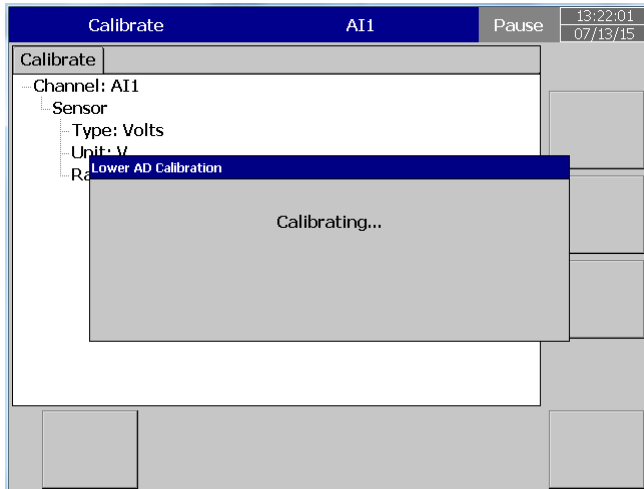

When the calibration is done successfully, the user can see below screen.

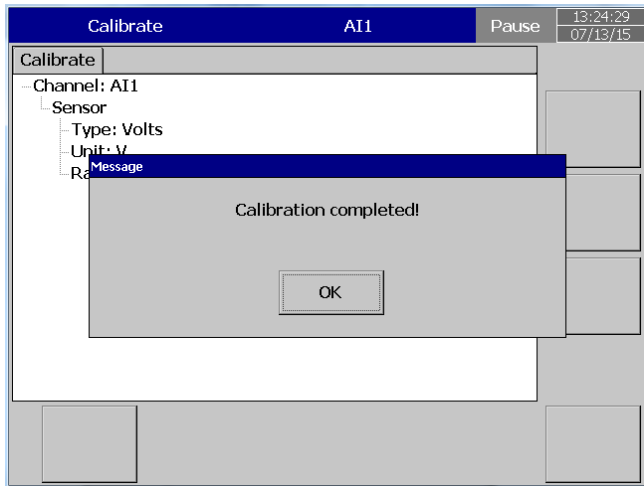

Example 2:

Calibrate an AI with Type K Thermocouple

Please note that, in order to calibrate the whole Module slot accurately, the 3rd channel of each slot must be calibrated first. Click OK.

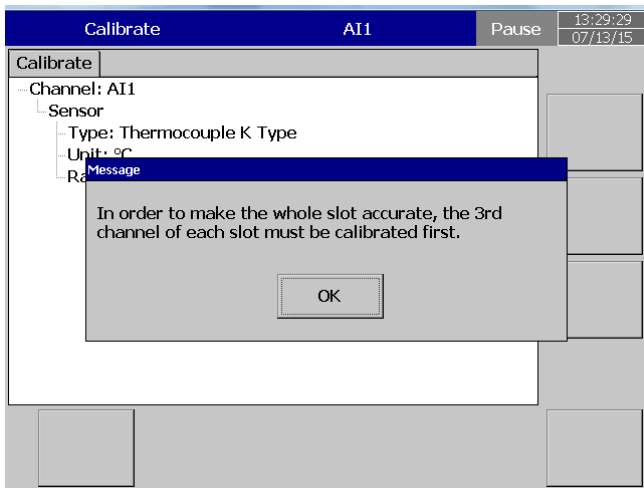

When you click Calibrate menu, the user can see the below screen. Please click calibrate as shown in the below screen

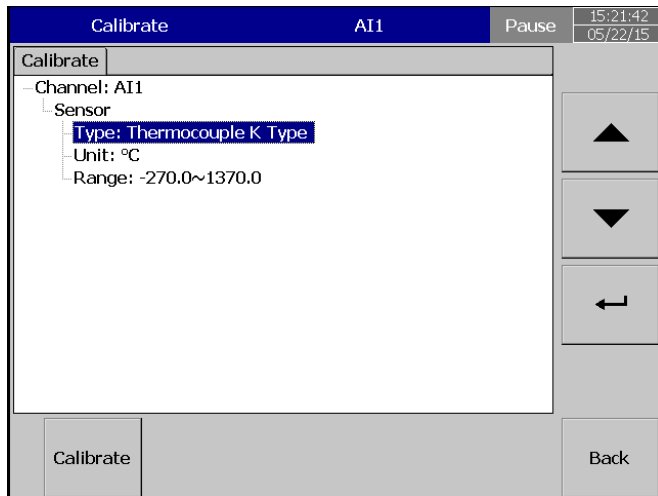

Click yes and proceed with the calibration process

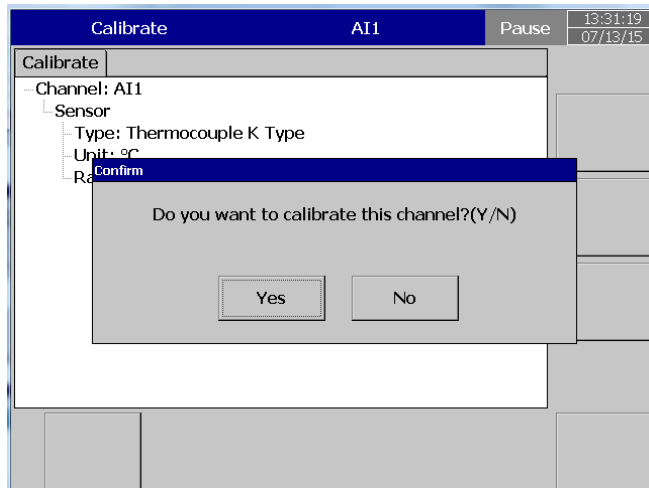

Please follow the next instruction, input 0 mV in to the input which can be seen in below screen

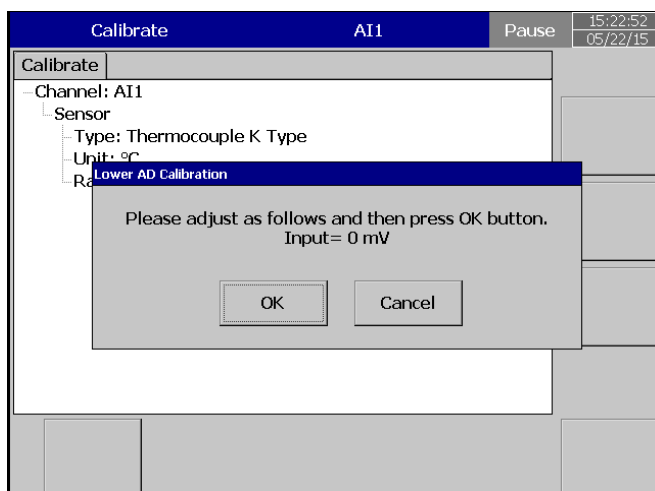

After you input 0V and select OK, the user can see the below screen.
Now follow the next instruction.

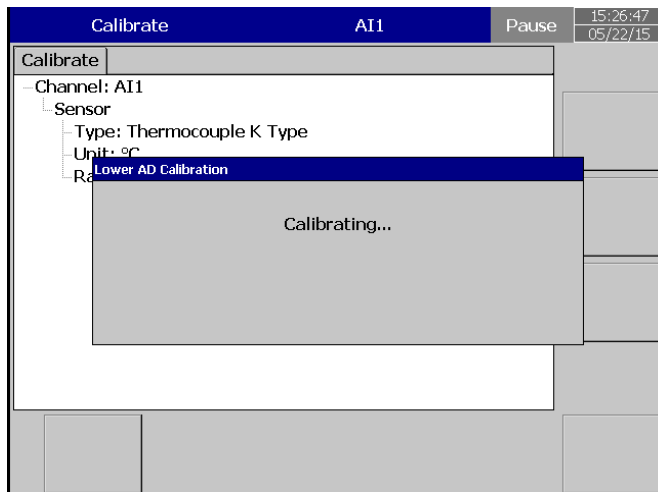

Now input 60mV and click OK

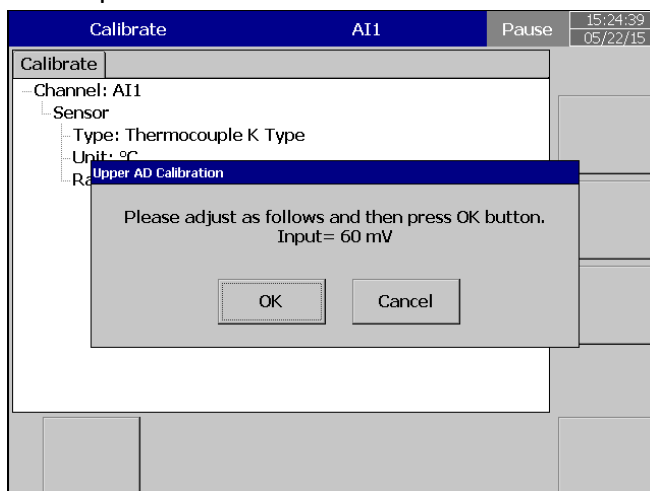

After you input 60 mV and select OK, the user can see the below screen
Now follow the next instruction.

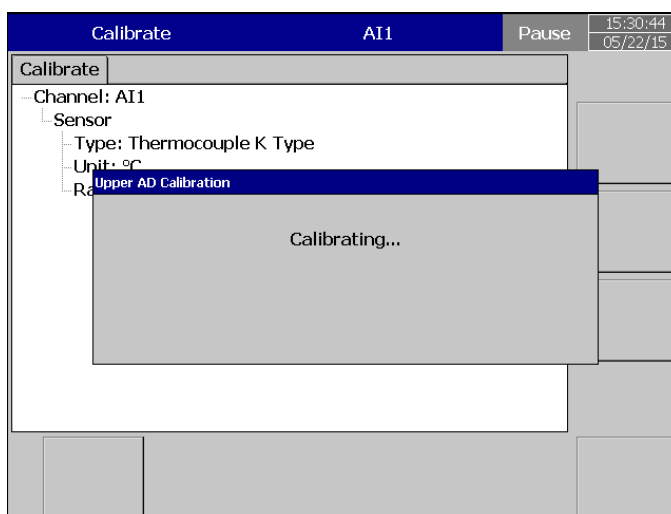

Now input 0°C from the simulator and press OK

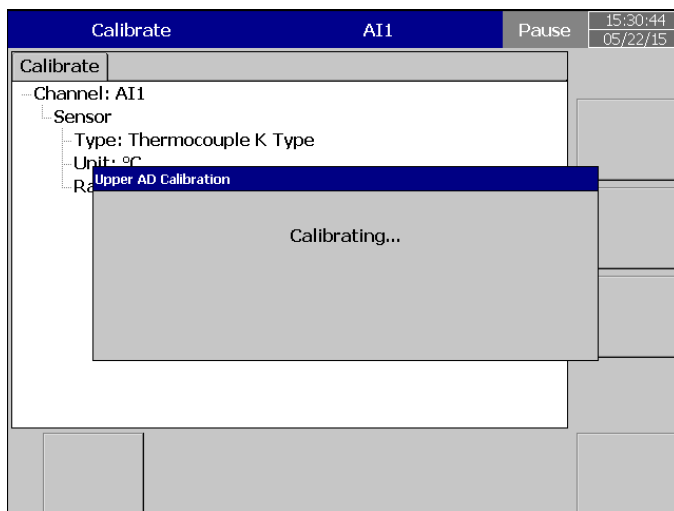
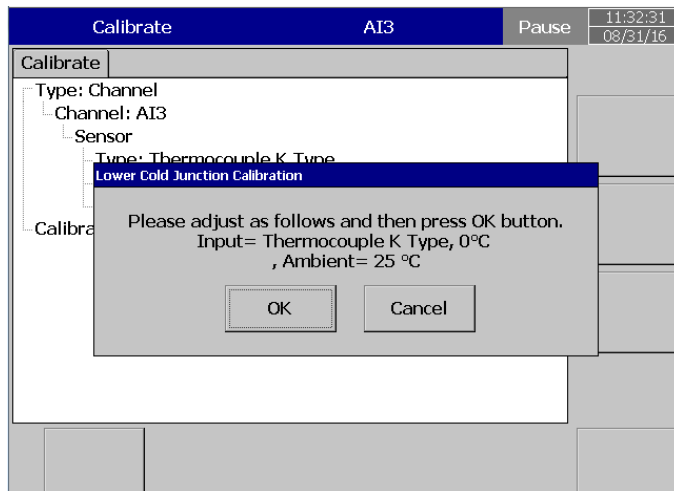

When the calibration is done successfully, the user can see below screen

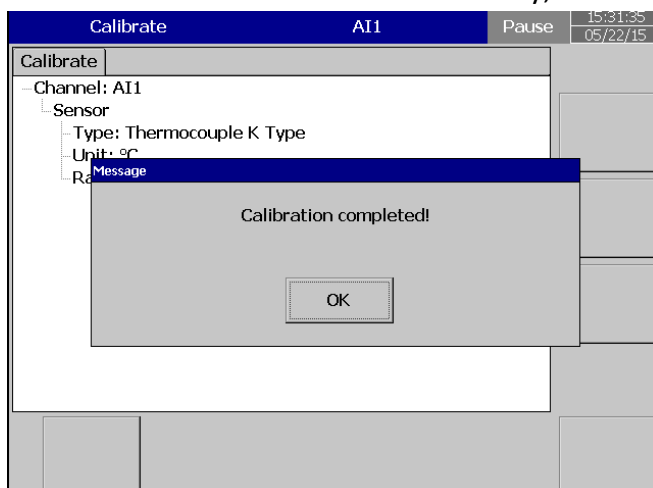

Calibrate an AO with 4-20mA

When you click Calibrate menu, the user can see the below screen. Please click calibrate as shown in the below screen

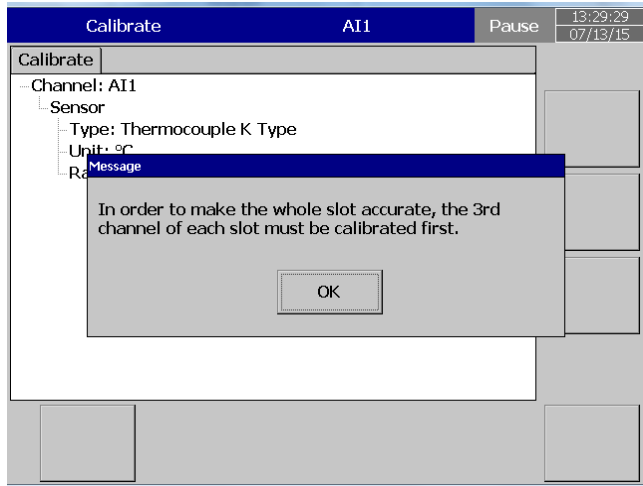

Click OK and proceed and select the channel of Analog Output to be calibrated.

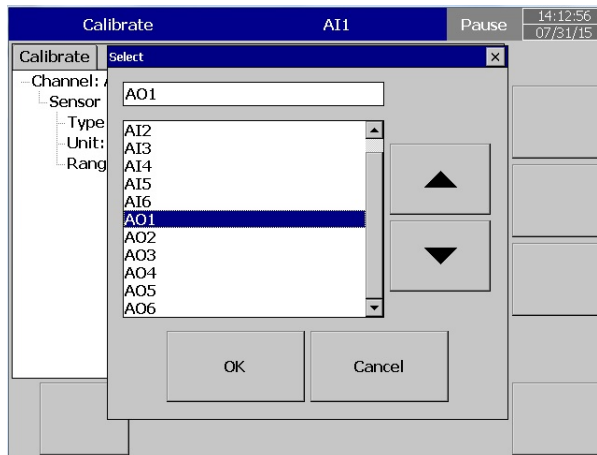

Confirm the channel to calibrate and click "Calibrate" and "yes" in the next screen

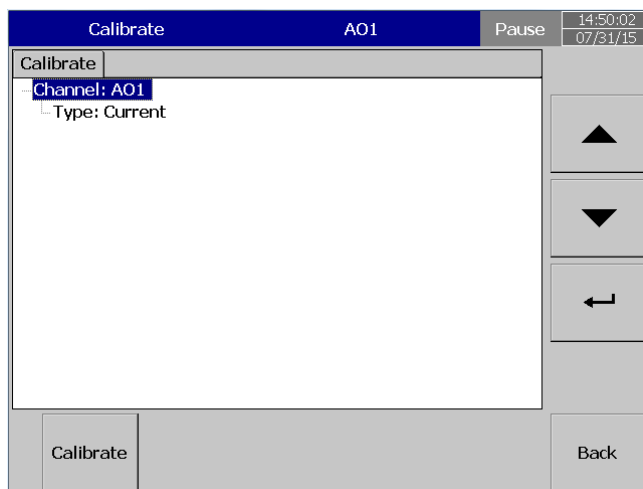

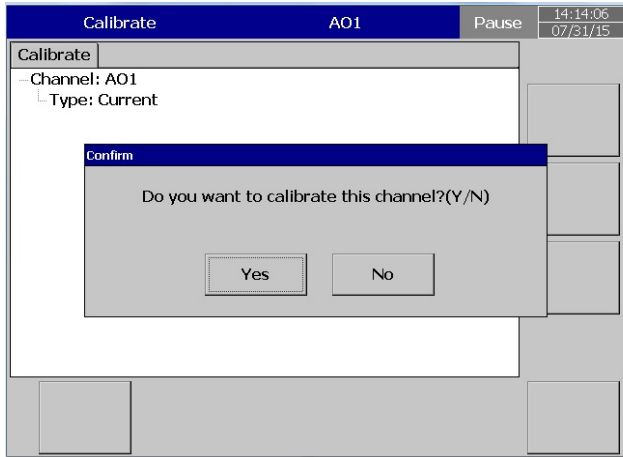

Please connect current meter before calibrating and click OK

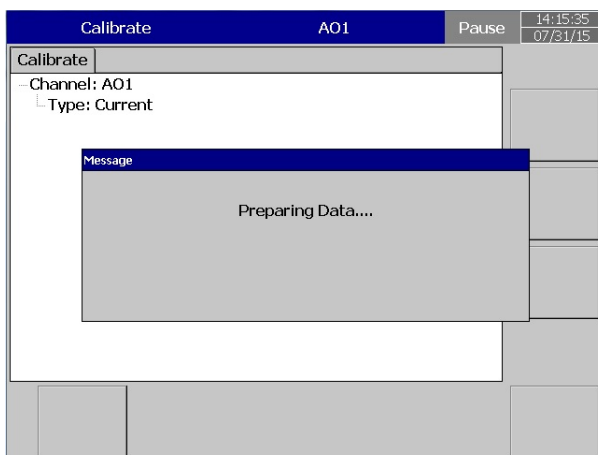
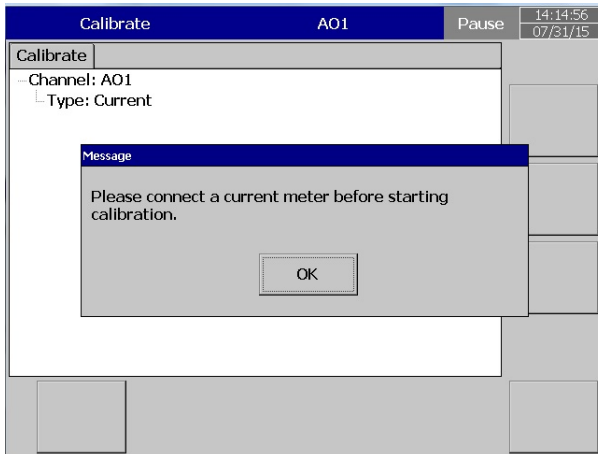

Then, input the value for Lower calibration, ie 2.7308 mA after clicking OK

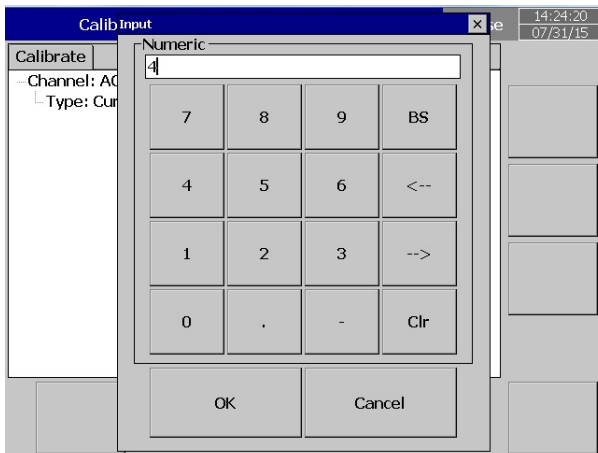
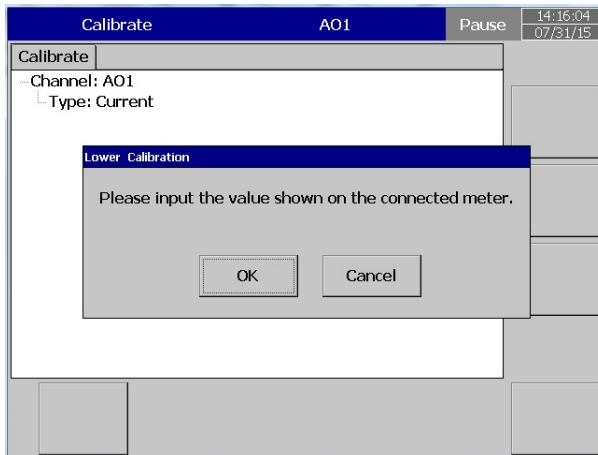

Lower calibration is in progress

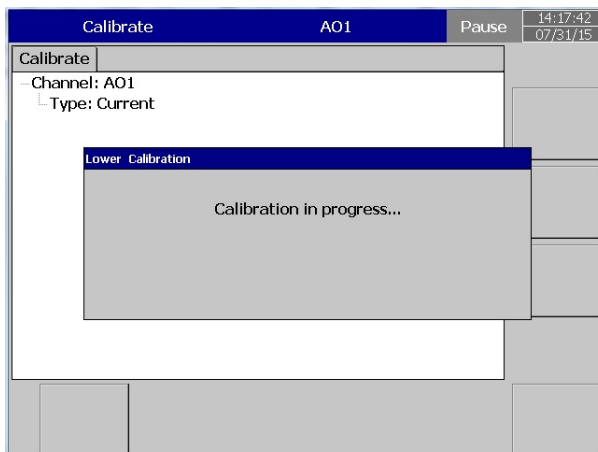

After we finish Lower calibration now, we need go for Upper calibration

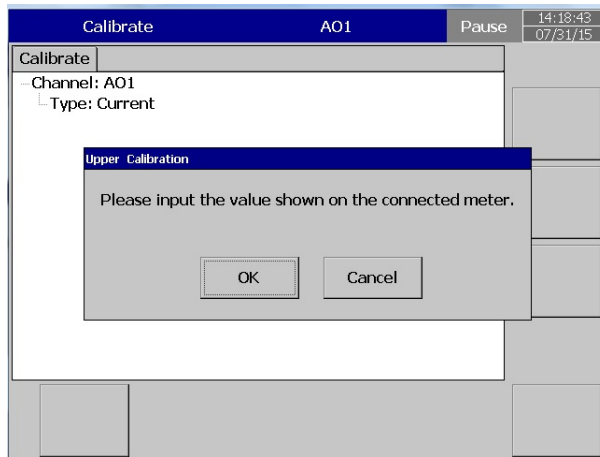

After clicking OK on the above enter upper calibration value as 18.745 mA and click OK

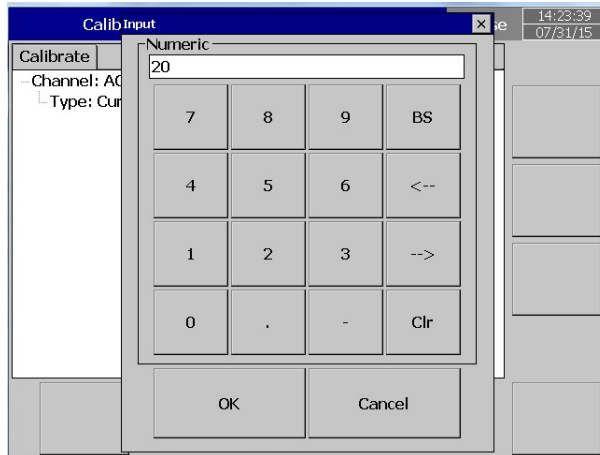

Upper calibration is in progress

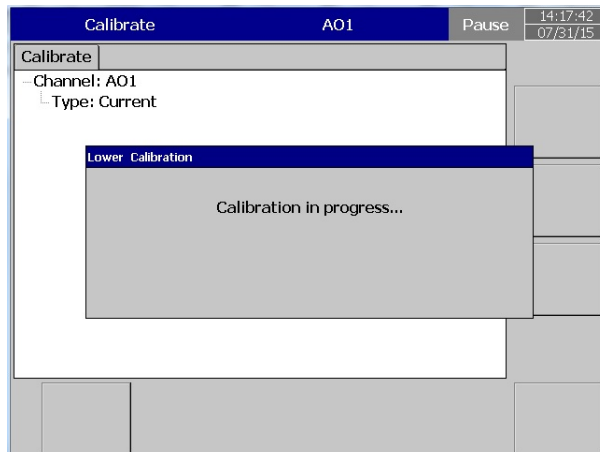

After we finish Upper calibration now, we need go for entering Offset

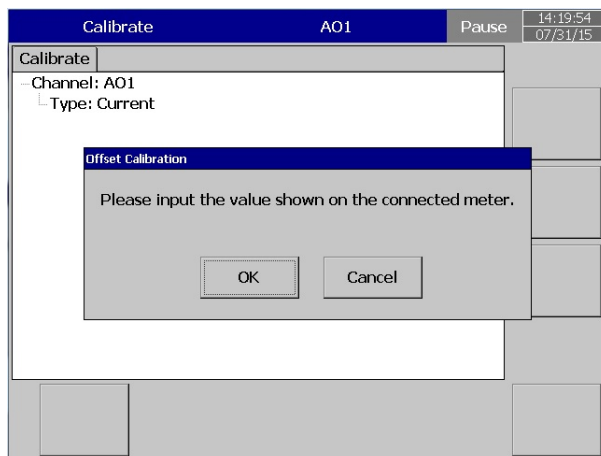

We enter 3.7554 mA as offset

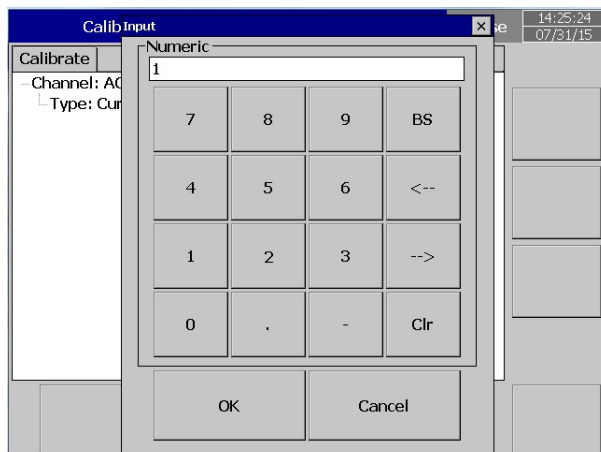

Offset calibration in progress

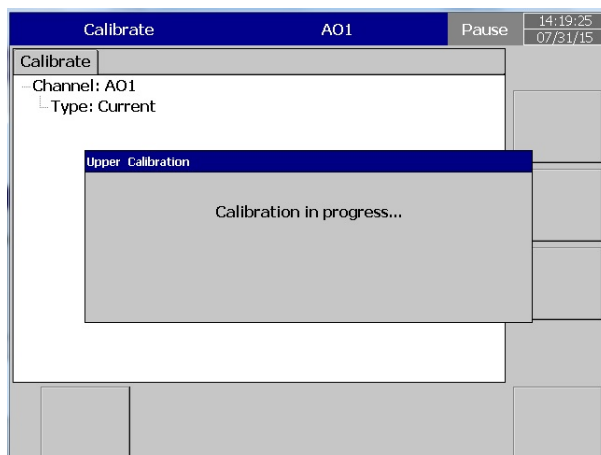

When the calibration is complete, we can see the below screen

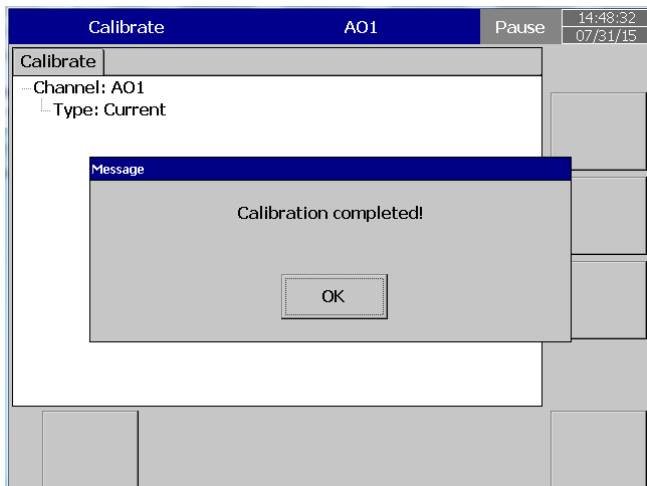

Note:

Channel #3 should be calibrated first in all types of Analog Input cards. An analog temperature sensor is installed in channel #3. When channel #3 is calibrating, the cold junction voltage measured by this temperature sensor will be loaded into a register. If channel #3 is not calibrated, the default value of cold junction voltage will be used for all channels. It does not matter what order you perform calibration after calibrating input 3, there is no need to follow a sequence, and any one of T/C, RTD, mA or VDC can be done independently.

3.13 Procedure To Reset and Restore Factory Default Settings

Power ON the Recorder while Pressing the Reset Button

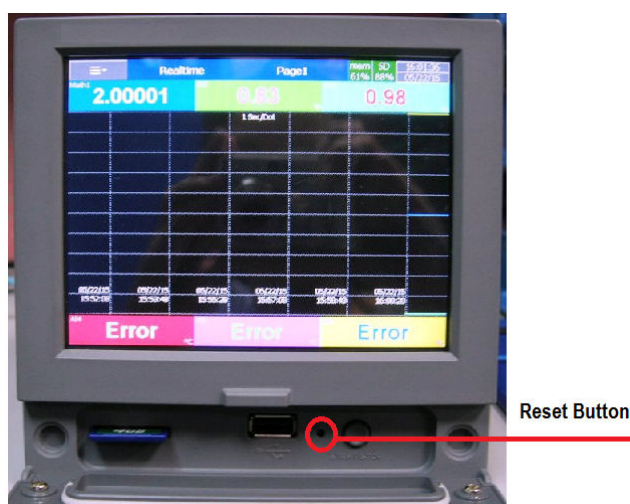

Now the Screen will appear like below

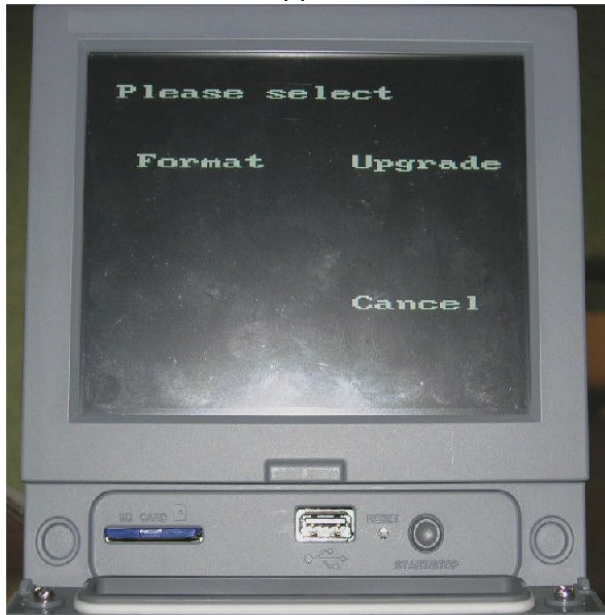

Format:

Press the Format Button for at least 3 Seconds to return the Recorder to factory Settings.

After the Recorder is done formatting, it will ask for Screen Calibration.

Do the Screen Calibration.

The recorder has now been returned to factory default settings.

Upgrade:

Download the Firmware from the FTP Link Given

Copy the File to the SD Card. Be sure the SD card is formatted to FAT32.

Insert the SD Card to the SD Card Slot on the Recorder.

Press Upgrade Button for at least 3 Seconds to upgrade the image from SD Card.

Follow the on-Screen instructions

3.14 Handwriting Messages on Trend Screens

Handwriting Messages on Trend Screens is very handy for process associates to highlight important events.

This is shown in the below picture.

When the User navigates through  (Menu) → History → Page 1, as shown in the below screen.

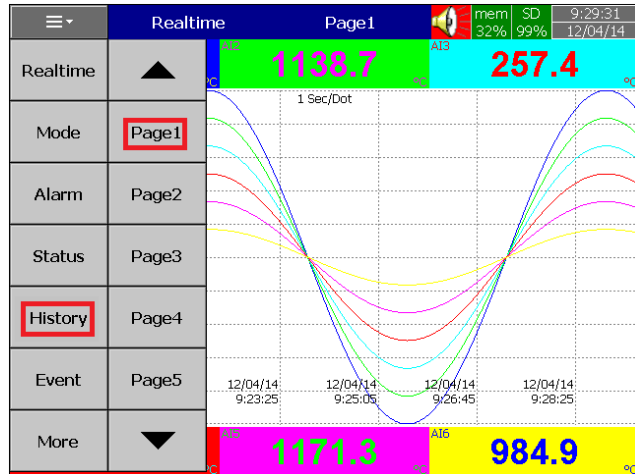

If the User wants to write a message, they can press the pen symbol as shown in the red square in the screen below

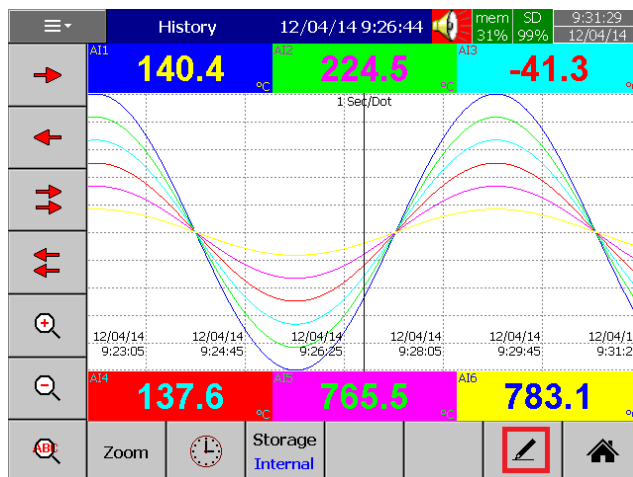

Then using the stylus, the User can write any message in Historical Trend Pages as shown below.

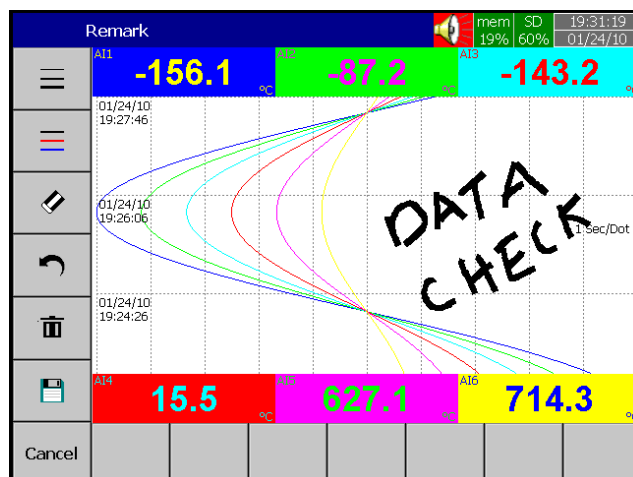

If the User wants to change the width of the written message, he/she can choose the width of pen as shown in the screen below. The menu to change the width is shown by the arrow pointing to the red box.

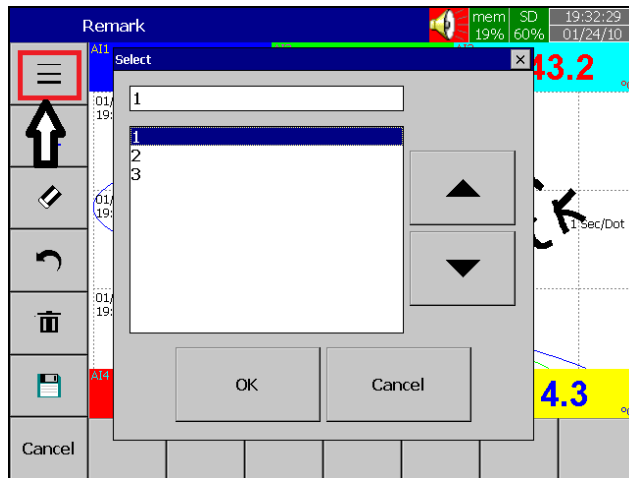

If the User wants to change color of the pen, he/she can change it by pressing the menu shown in the red box in the picture below.

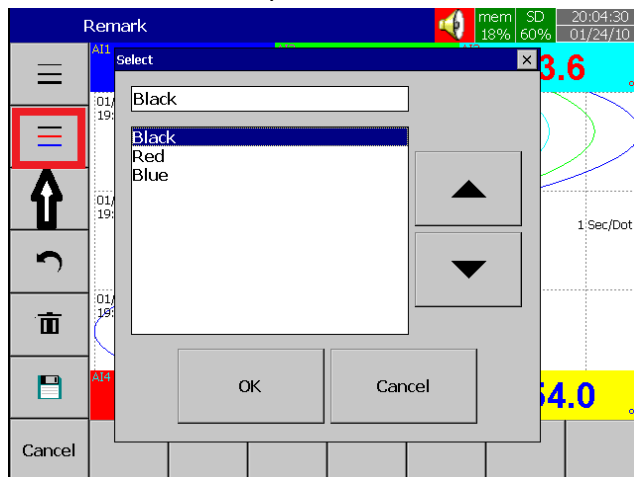

If the User wants to erase part of a message, he/she can do this by pressing the menu (shown in the red box in the picture below), and erase part of the message.

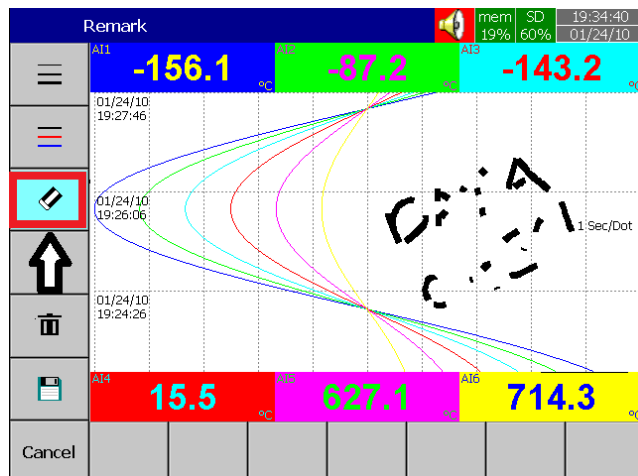

If the User wants to undo part of a message, he/she can do this by pressing the undo symbol (shown in the red box in the picture below). This will undo the last part of the message.

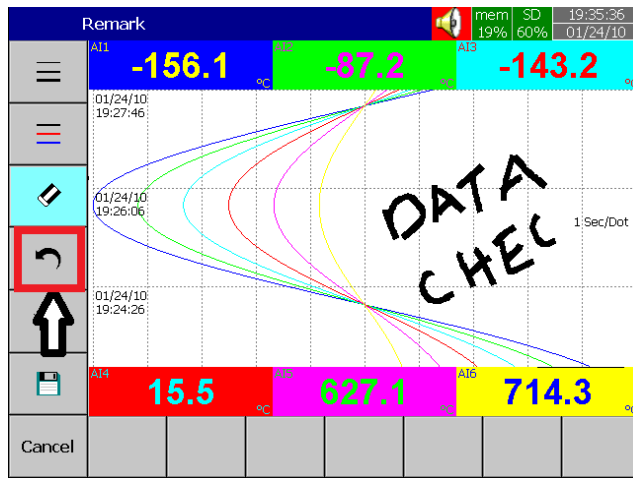

If the User wants to delete the written message, he/she can do this by pressing the delete symbol (shown in the red box in the picture below), and this will delete the written message.

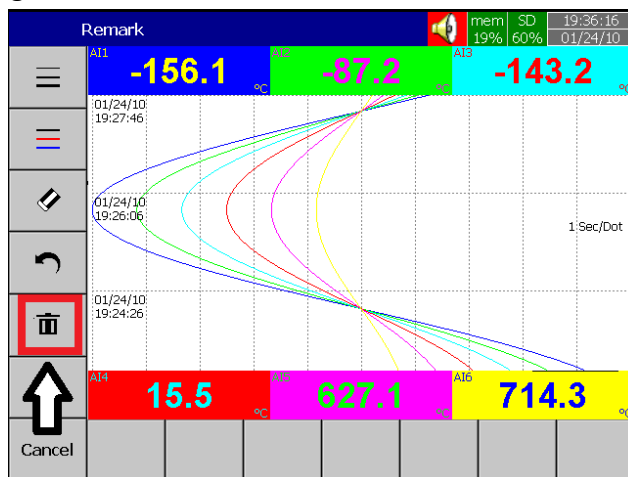

If the User wants to save the written message, he/she can do this by pressing the "save" symbol (shown in the red box in the picture below). This will save the written message.

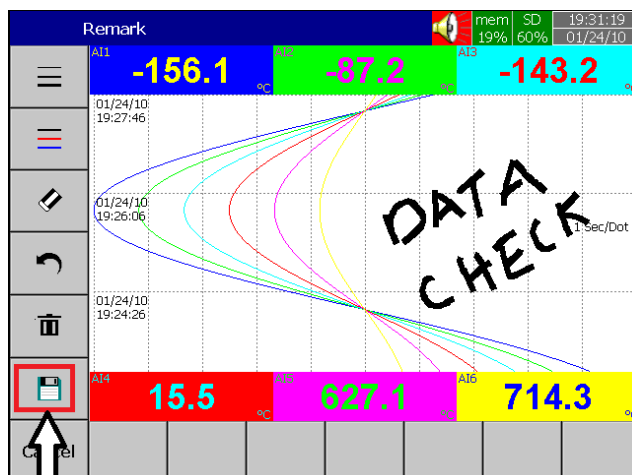

4. WEBSERVER

It is used to view Paperless Recorder from a Remote location via Internet.

4.1 How to configure Web server Settings

For using Web server application in the PPS series Recorder, Configuring the Recorder for a static IP address, and enabling the Web server.

4.1.1 How to Configure Static IP Address

In the Configuration screen, select “Communication”, then press the “Enter” soft key

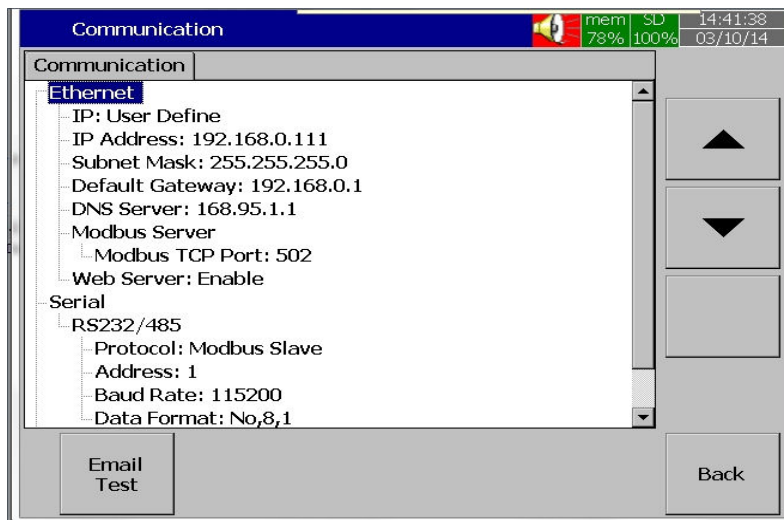
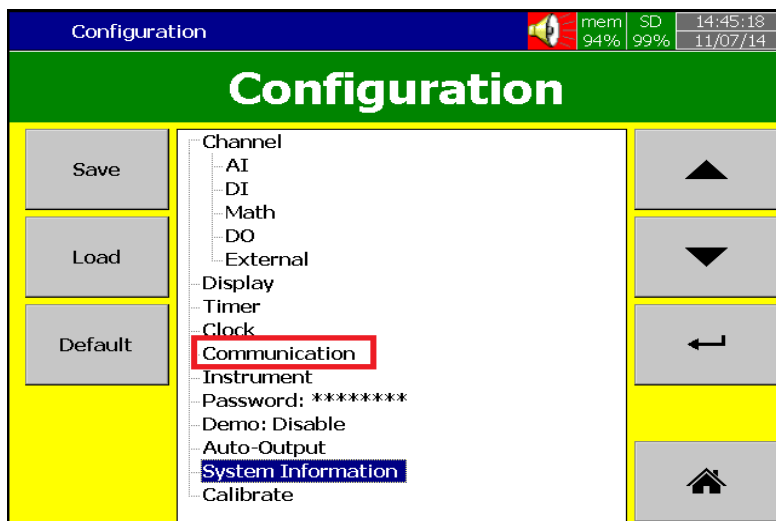

Select IP type = User Define.

Enter the IP Address, Subnet Mask, Default Gateway, and DNS Server Settings in the Ethernet Settings.

Note: Make sure to enter Global, Unique, static fix IP address received from Internet solution provider.

4.1.2 How to Enable Web Server

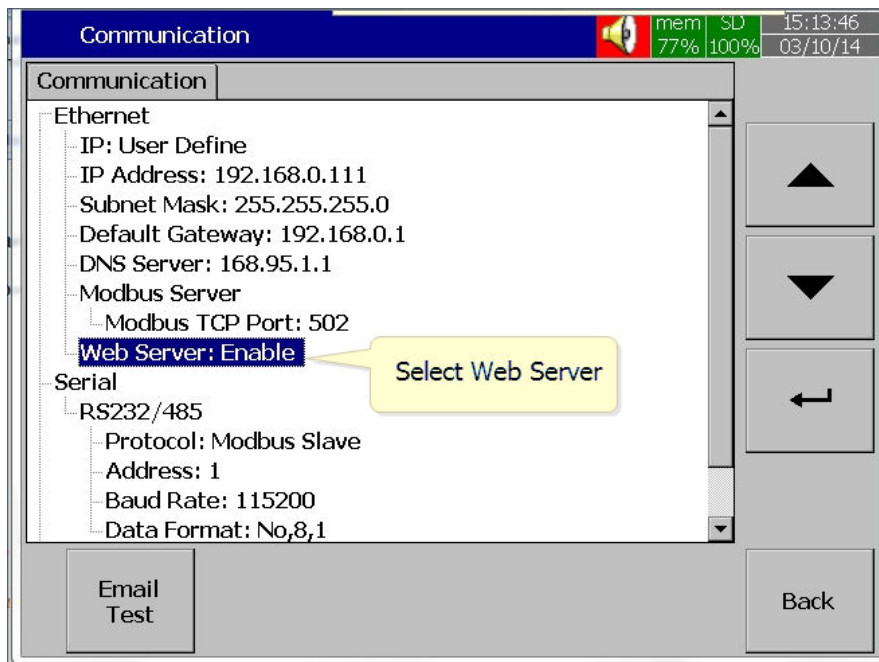

Select Web Server Menu in the Communication screen.
Enable the Web Server for using Web Server application in the Recorder.

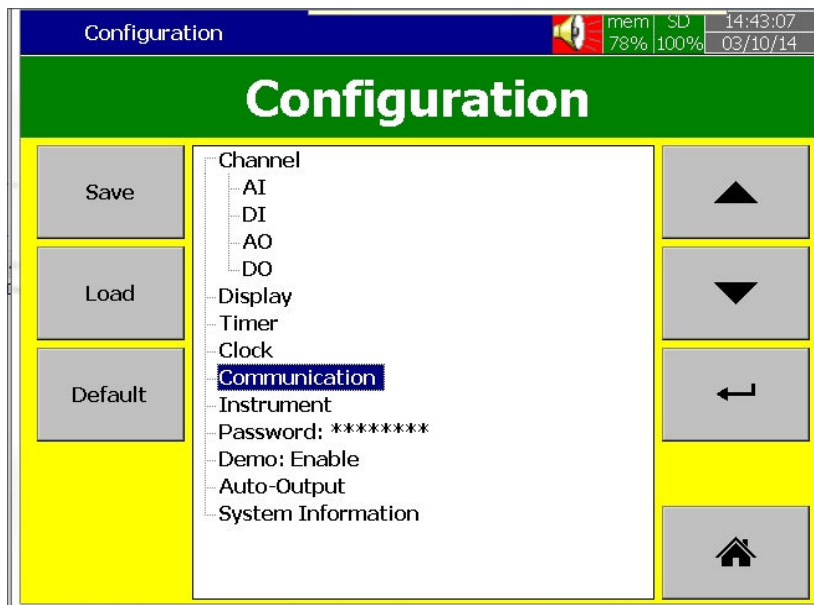

After completing the above steps, press the "BACK" key, then the "Home" key to return to the main menu. It will save the configuration settings in the Recorder.

Now the Recorder is ready for the Web Server Applications.

Note: The Web Server update time on the browser is 1 second for real time data and statuses and 5 Seconds for Alarms.

4.2 How to View Recorder Data in PC via Webserver

Connect Paperless Recorder to the Internet

Open the browser (Internet Explorer 10 or Google Chrome) in the PC

Enter the IP address of the Recorder in the address bar of the browser.

Format: <http://192.168.1.111>

Now you can see the Paperless Recorder screens in browser as shown below



The display includes Real time values of all channels like AI, Math, Counters, Totalizers, Real time alarms, historical alarms, status of Digital Inputs, Digital Outputs, Analog Outputs, Counters, and Totalizers etc.

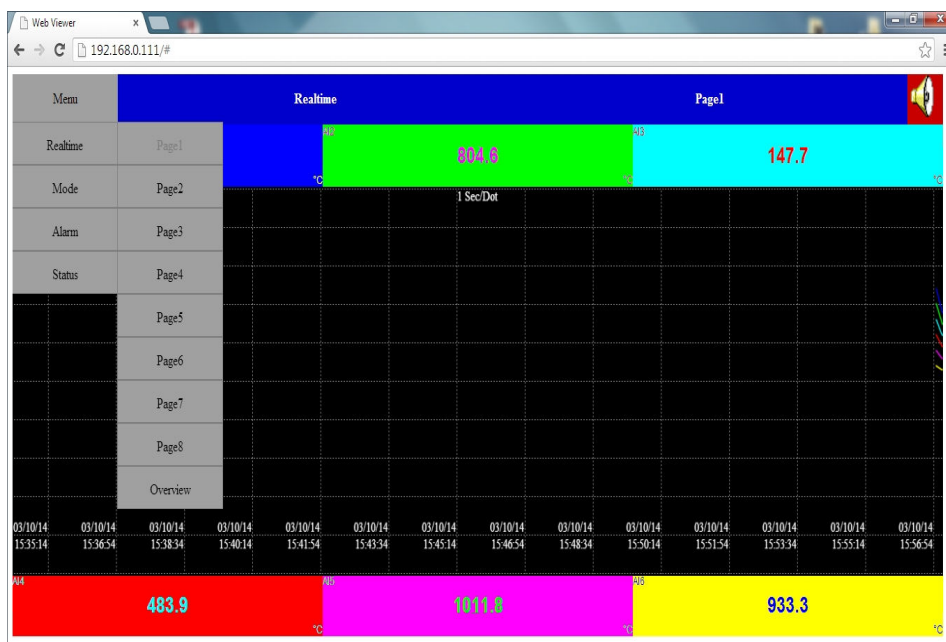

Press Overview to view the summary of all data in single screen

Memm	Realtime			Overview		
AI1	159.4 °C	257.3 °C	-33.5 °C	274.7 °C	758.0 °C	
AI6	810.1 °C	1495.3 °F	1869.2 °F	426.7 °F	1051.7 °F	
AI11	2033.6 °F	1799.6 °F	16.60 %	27.70 %	38.86 %	
AI16	83.40 %	72.26 °F	61.13 °F	-48.4 °F	65.8 °F	
AI21	-170.5 °F	362.5 °F	1197.4 °F	1393.4 °F	Counter9	0
Math2	1611.9	460.2	777.0	1275.6	989.5	
Math7	61.1	72.3	83.4	83.4	72.3	
Math12	61.1	207.8	191.5	137.0	-87.8	

By pressing “Mode”, you can view the data in Bar Graphs, Trends and Digital Values. By Pressing Trend you can view the data in trends.

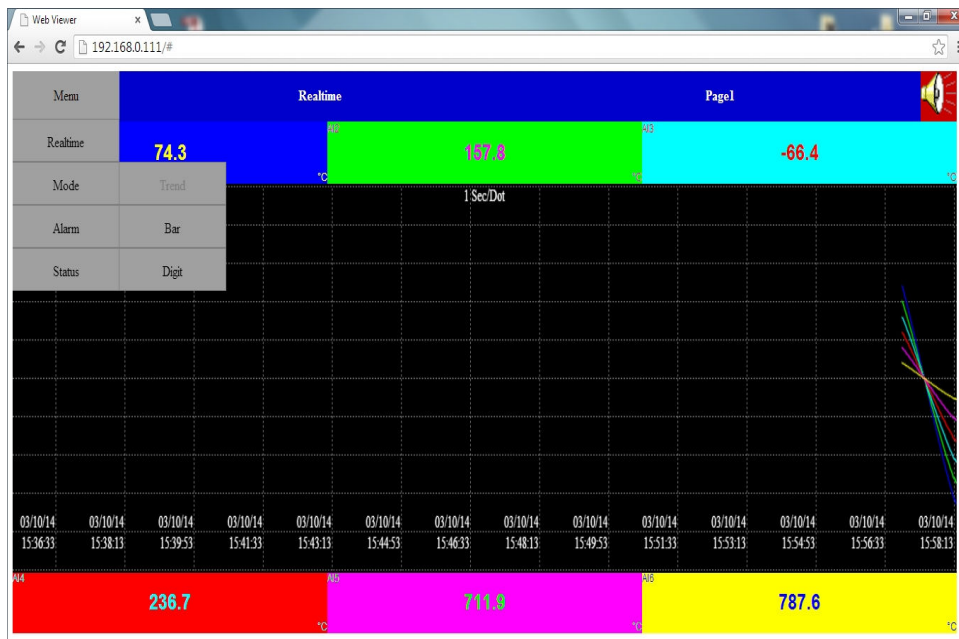

By pressing “Bar”, you can view the data in Bar Graphs

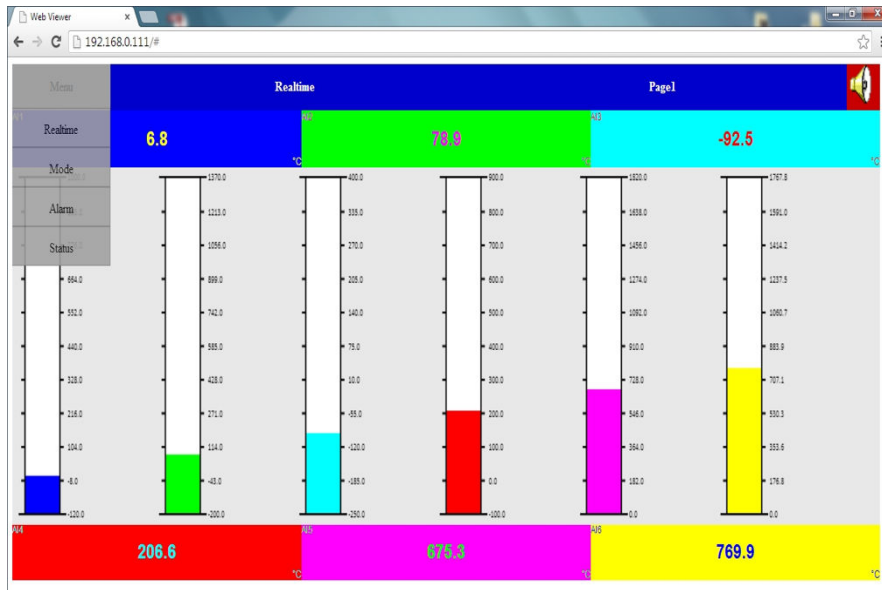

By pressing “Digit”, you can view the Data in the digital format



By pressing “Alarm”, you can view the List of Alarms along with the detail

No.	Active Time	Acked	Type	Name	Value
1	10/10/14 10:11:14		LoAlarm	AI1	10.10
2	10/10/14 10:11:12		LoAlarm	AI2	10.10
3	10/10/14 10:11:12		LoAlarm	AI3	10.10
4	10/10/14 10:11:12		HiAlarm	AI4	10.10
5	10/10/14 10:11:12		HiAlarm	AI5	10.10
6	10/10/14 10:11:12		HiAlarm	AI6	10.10
7	10/10/14 10:11:12		HiAlarm	AI7	10.10
8	10/10/14 10:11:12		HiAlarm	AI8	10.10
9	10/10/14 10:11:12		HiAlarm	AI9	10.10
10	10/10/14 10:11:12		HiAlarm	AI10	10.10
11	10/10/14 10:11:12		LoAlarm	AI11	10.10
12	10/10/14 10:11:12		LoAlarm	AI12	10.10
13	10/10/14 10:11:12		LoAlarm	AI13	10.10
14	10/10/14 10:11:12		LoAlarm	AI14	10.10
15	10/10/14 10:11:12		LoAlarm	AI15	10.10
16	10/10/14 10:11:12		LoAlarm	AI16	10.10
17	10/10/14 10:11:12		LoAlarm	AI17	10.10
18	10/10/14 10:11:12		LoAlarm	AI18	10.10
19	10/10/14 10:11:12		LoAlarm	AI19	10.10
20	10/10/14 10:11:12		LoAlarm	AI20	10.10
21	10/10/14 10:11:12		LoAlarm	AI21	10.10
22	10/10/14 10:11:12		LoAlarm	AI22	10.10
23	10/10/14 10:11:12		LoAlarm	AI23	10.10
24	10/10/14 10:11:12		LoAlarm	AI24	10.10
25	10/10/14 10:11:12		LoAlarm	AI25	10.10
26	10/10/14 10:11:12		LoAlarm	AI26	10.10
27	10/10/14 10:11:12		LoAlarm	AI27	10.10
28	10/10/14 10:11:12		LoAlarm	AI28	10.10
29	10/10/14 10:11:12		LoAlarm	AI29	10.10
30	10/10/14 10:11:14		LoAlarm	AI30	10.10

By pressing “Status”, you can view the status of the Analog outputs, Digital Inputs, Digital Outputs, Counters and Totalizers.

By pressing “DI”, you can view the status of the Digital Inputs

By pressing “DO”, you can view the status of the Digital outputs

DI	DO	AO	Counter	Totalizer	No.	Name	Value
					1	DI1	Hi
					2	DI2	3
					3	DI3	Hi
					4	DI4	3
					5	DI5	Hi
					6	DI6	3

DI	DO	AO	Counter	Totalizer	No.	Name	Value
					1	DO1	Off
					2	DO2	Off
					3	DO3	Off
					4	DO4	Off
					5	DO5	Off
					6	DO6	Off

By pressing "AO", you can view the status of the Analog Outputs

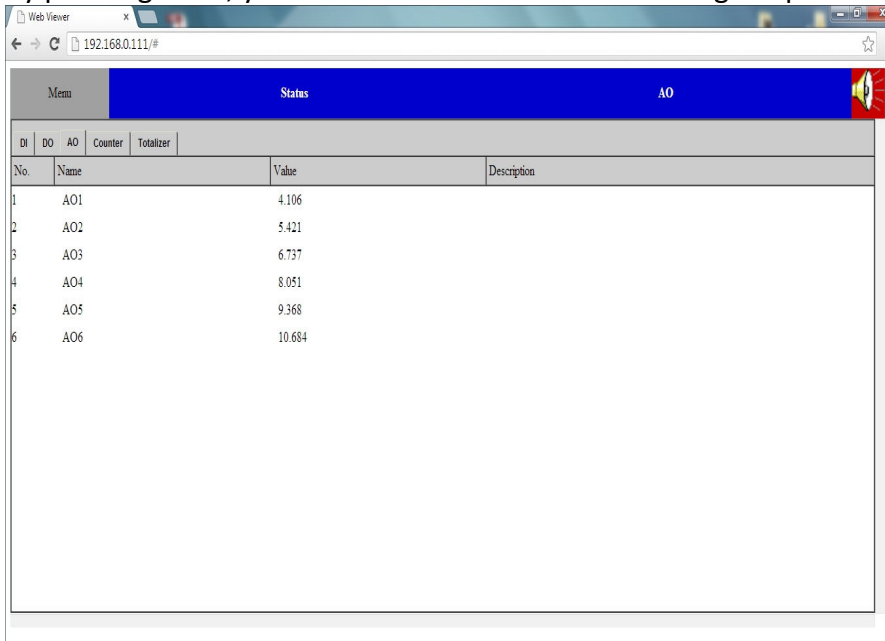

DI	DO	AO	Counter	Totalizer	No.	Name	Value	Description
					1	AO1	4.106	
					2	AO2	5.421	
					3	AO3	6.737	
					4	AO4	8.051	
					5	AO5	9.368	
					6	AO6	10.684	

By pressing "Counters", you can view the status of the counters

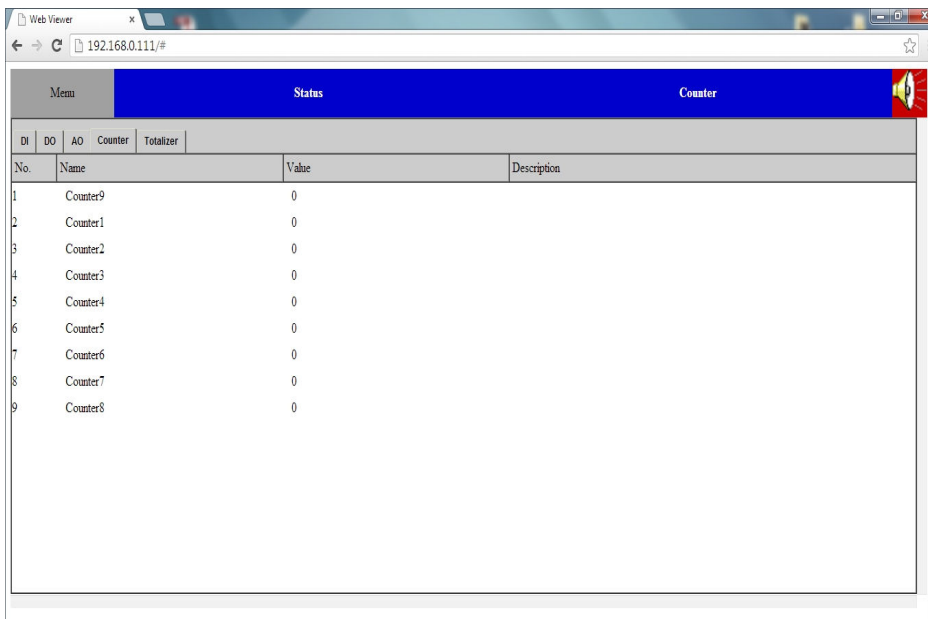

DI	DO	AO	Counter	Totalizer	No.	Name	Value	Description
					1	Counter9	0	
					2	Counter1	0	
					3	Counter2	0	
					4	Counter3	0	
					5	Counter4	0	
					6	Counter5	0	
					7	Counter6	0	
					8	Counter7	0	
					9	Counter8	0	

By pressing “Totalizers” you can view the status of the totalizers.

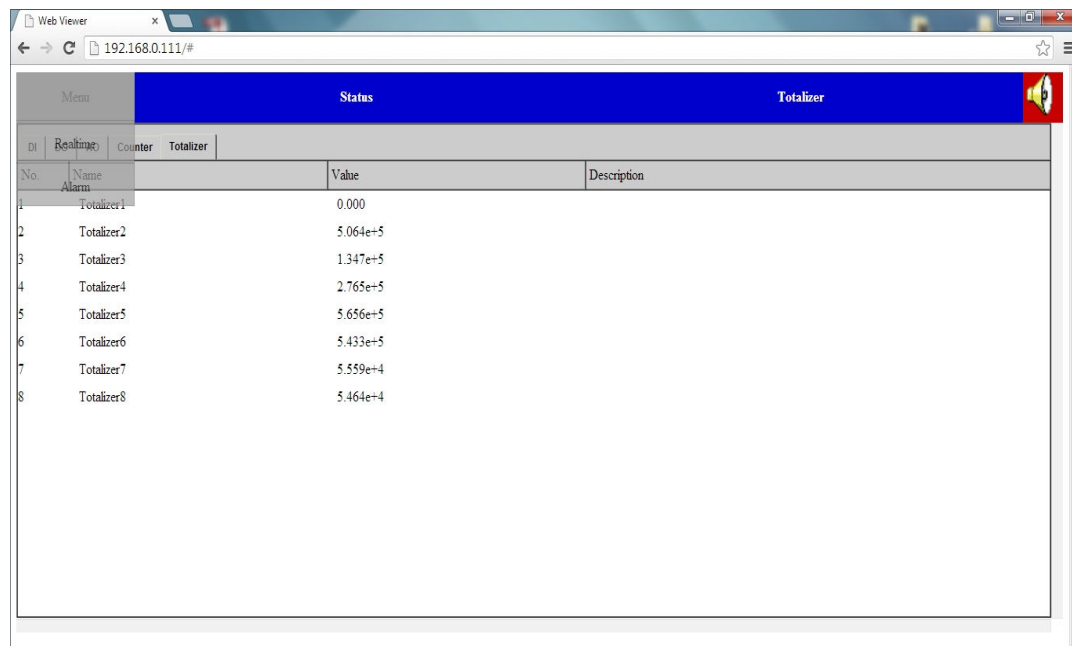

Menu		Status	Totalizer
No.	Name	Value	Description
1	Totalizer1	0.000	
2	Totalizer2	5.064e+5	
3	Totalizer3	1.347e+5	
4	Totalizer4	2.765e+5	
5	Totalizer5	5.656e+5	
6	Totalizer6	5.433e+5	
7	Totalizer7	5.559e+4	
8	Totalizer8	5.464e+4	

Custom Manufacturer Since 1972

ELECTRIC HEATING ELEMENTS • TEMPERATURE CONTROLS • SENSORS • PROCESS HEATING SYSTEMS

HEAT THINGS UP!

With Thousands of Design Variations
We Make Everything You Need.

Band Heaters	Cartridge Heaters
Cast-In Heaters	Coil & Cable Heaters
Radiant Heaters	Strip Heaters
Flexible Heaters	Tubular Heaters
Process Heaters	Instrumentation
Temperature Control	Temperature Sensors



607 N. Central Avenue Wood Dale, IL 60191-1452 USA
P: 630-350-2252 Toll Free: 800-323-6859
F: 630-350-0232 E: info@tempco.com
www.tempco.com