

# TEMPCO®

## USER MANUAL

### PCM20096 - Power Control Console

with TEC-9400 (PID + Fuzzy Logic Process Controller)  
and TEC-960 FM High Limit,  
120VAC, 50/50Hz, Fused at 20A





## SPECIFICATIONS

**Temperature Controller:** Model TEC-9400, Dual Display with PID Auto-tuning

**Hi-Limit Controller:** Model TEC-920, FM Approved with Dual Display

**Sensor Inputs:** Type “K” Thermocouples

**Connector Bodys:** Yellow, flat mini-blade

**Power Cord/voltage Input:** 120VAC, 50/60 HZ, 20Amp, NEMA 5-20

**Heater Output:** 16A Max, 1920 watts max

**Output Devices:** Mechanical Relays

**Main Power Switch:** Located on front panel

**Fuse Main Power:** See replacement parts list on next page (located on back panel)

**Fuse Control Power:** See replacement parts list on next page (located on back panel)

## WARNINGS

1. To prevent an overheating condition the internal components must remain as close to room temperature (75°F / 24°C) as possible.
2. Dangerous voltage capable of causing injury or death is present within this console. Power to all equipment must be disconnected before installation or beginning any troubleshooting procedures. **Heater output wiring and component replacement must be made by qualified personnel only.**
3. To minimize the possibility of fire or shock, do not expose this console to rain or excessive moisture.
4. Do not use this console in areas where hazardous conditions exist such as excessive shock, vibration, dirt, corrosive gases, oil or where explosive gases or vapors are present.

## WIRING (For safety, disconnect all power sources prior to wiring)

1. Attach the leads from your type K thermocouple sensors to the mini-plugs provided. Take care to note the correct polarity. The yellow lead is positive.
2. The heater output current is sourced directly through the line cord. The rear console output receptacle and mating Hubbell plug provide live controlled power for direct connection to your heater(s). Connect one lead from your heater to one prong of the Hubbell plug (not ground). Connect the other lead from your heater to the other prong. Connect heater ground (if applicable) to the ground connection (G) on the plug.

### **TEC-960:**

Press “R” key to silence Alarm.

Press again to reset after temperature falls to energize heater.

**Also see page 44.**

## WARNINGS

1. Verify the power switch is in the off position. Plug your heater(s) & thermocouples into the rear connectors. Plug the provided line cord from the console into a 120V, 20A outlet. Switch on the console.
2. Set your desired temperature setpoints by using the up and down arrow buttons on the TEC-9400 temperature controller, and TEC-960 High-Limit.
3. Refer to the following pages for complete operation and page 4 for auto-tuning of the TEC-9400 temperature controller and page 21 for the TEC-960 High-Limit.

## SPARE REPLACEMENT PARTS

Tempco Part Number	Description
EHD-124-213	Fuse (1), rated 20 Amp/250V, ¼ x 1 ¼”, fast acting BUSS ABC-20-R. Used for main control console power.
EHD-124-276	Fuse (1), rated 1 Amp/ 250V, ¼” x 1¼”, fast acting, BUSS ABC-1-R. Used for TEC Controllers.
EHD-102-140	Power output plug, Hubbell HBL5366C, 20A 125V Straight-Blade.
TCA-101-104	T/C mini-plugs, (2) type K, yellow, CMP-KA

**NOTE:** For all fuses, use listed BUSS part numbers or equivalent.

## 1-5. TEC-9400 Front Panel Keys and Display

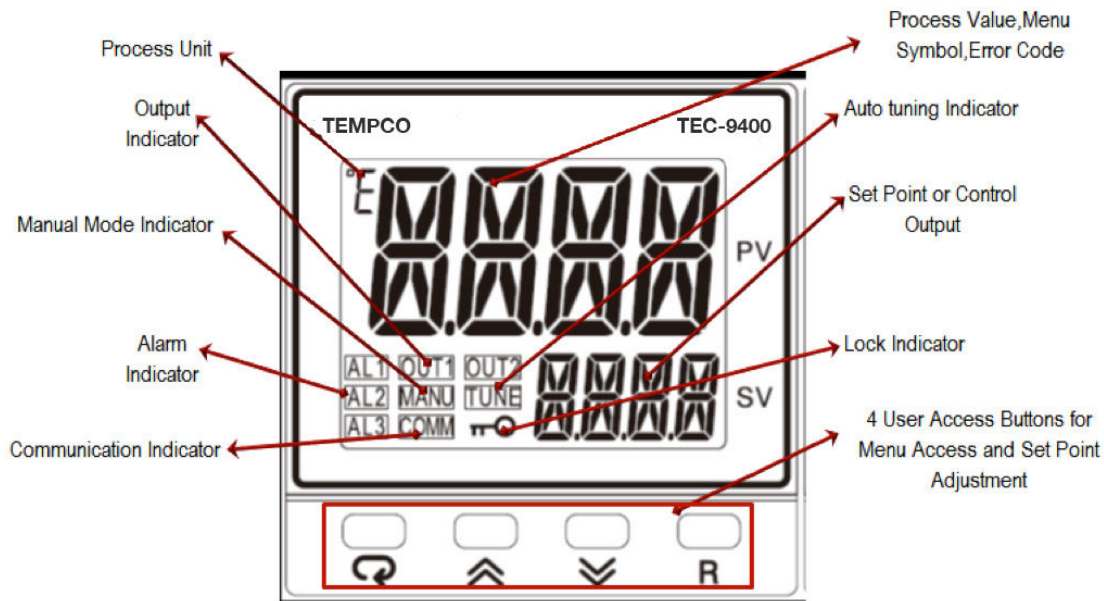

### KEYPAD OPERATION

#### SCROLL KEY:

This key is used to scroll through a menu to select a parameter to be viewed or adjusted.

#### UP KEY:

This key is used to increase the value of the selected parameter.

#### DOWN KEY:







This key is used to decrease the value of the selected parameter.

#### RESET KEY:

This key is used to:

1. Revert the display to the home screen.
2. Reset a latching alarm once the alarm condition is removed.
3. Stop manual control mode, Auto-Tuning mode or calibration mode.
4. Clear an Auto-Tuning or communication error message.
5. Restart the dwell timer when the dwell timer has timed out.
6. Enter the manual control menu if failure mode occurs.

#### ENTER KEY:

1. Enter the setup menu. The display will show .
2. Enter manual control mode. Press and hold  for 6.2 seconds, then let go to enter manual mode. The display will show .
3. Enter Auto-Tuning mode. Press and hold  for 7.4 seconds, then let go to select Auto-Tuning. The display will show .
4. Perform calibration of a selected parameter during the calibration procedure. Press and hold  for 8.6 seconds, then let go to select calibration mode.

During power-up, the upper display will show PROG and the lower display will show the Firmware version for 6 seconds.

# 1.1 Menu Flowchart

The Menu has been divided into 5 groups. They are as follows:

1. User Menu - Below
2. Setup Menu - Page 5
3. Manual Mode Menu - Page 7
4. Auto-Tuning Mode Menu - Page 7
5. Calibration Mode Menu (not recommended, calibration section has been removed)

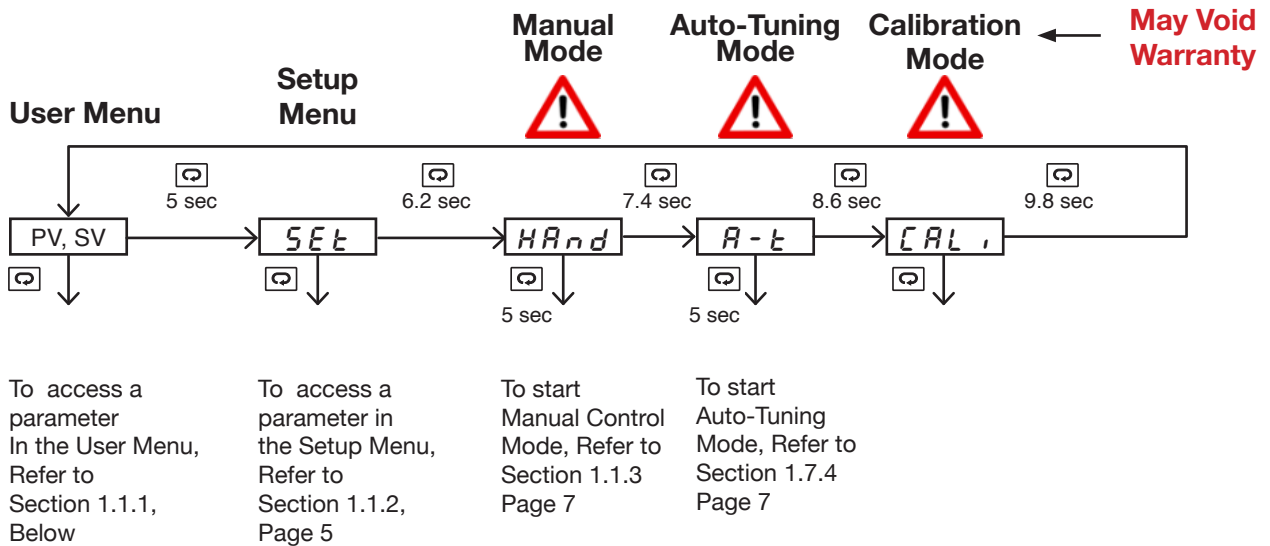

Press for the next parameter  
 Press and key to return to the previous parameter

## 1.1.1 User Menu

The following user menu parameters are available depending on the current setup configuration of the controller.

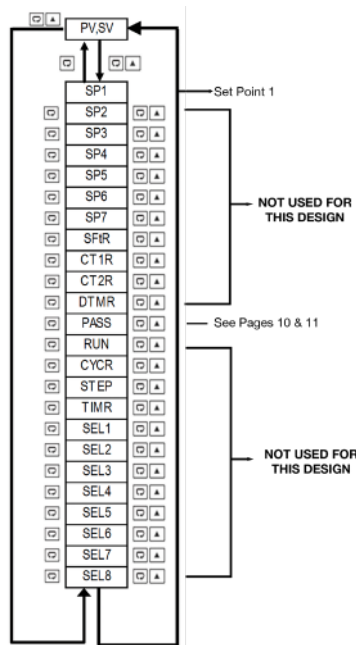

**NOTE PG. 19  
FOR TEC-9400  
ERROR CODES**

## 1.1.2 Setup Menu

The setup menu has been categorized in to eight categories. They are listed below.

1. Basic Menu - Below
2. Output Menu (Pg. 6)
3. Alarm Menu \*
4. Event Input Menu \*
5. User Select Menu \*
6. Communication Menu \*
7. Current Transformer Menu \*
8. Profile Menu (Ramp and Soak) \*

### 1.1.2.1 Basic Menu (bASE)

In the setup menu, when the upper display says “SET”, Use the ▲ or ▼ keys to get “bASE” in the lower display. Then use the ◻ key to cycle through the “bASE” menu parameters.

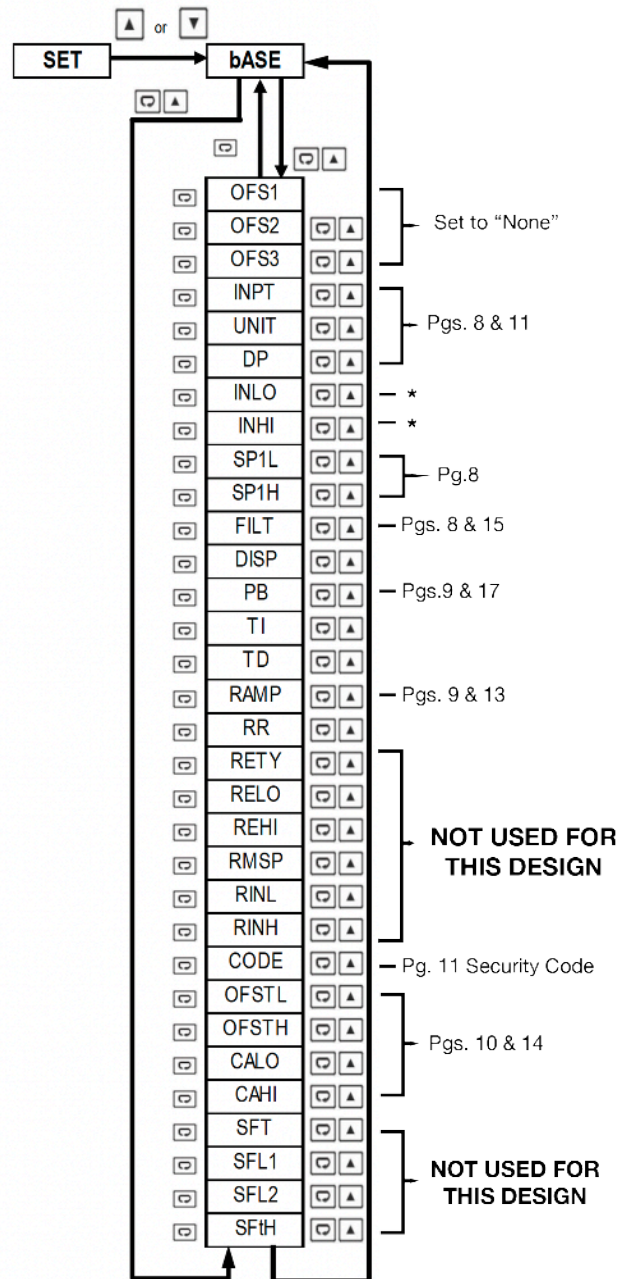

**\* NOT USED IN THIS DESIGN**

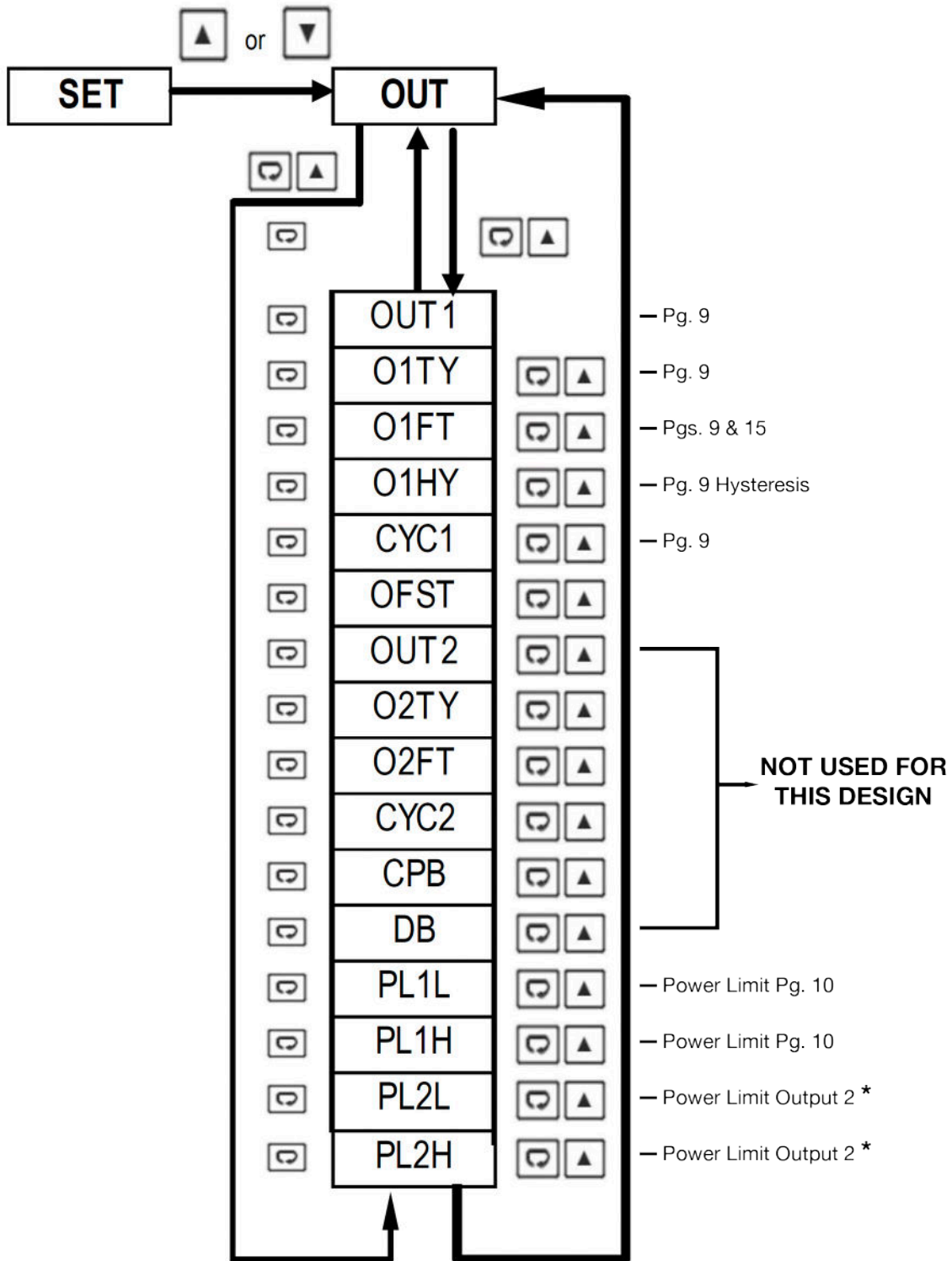

### 1.1.2.2 Output Menu (oUT)

In the setup menu, when the upper display says “SET”, use the ▲ or ▼ key to get “oUT” in the lower display. Then, use the ◀ key to cycle through the “oUT” menu parameters (Note Chart on pg.9).



**\* NOT USED IN THIS DESIGN**

### 1.1.3 Manual Mode Menu Used If Sensor Fails (See Pg. 15)

Press and hold the “” key for approx. 6sec until the “HAND” parameter is shown in the upper display. Then, press and hold the “” key for an additional 5 sec. until an “MANU” led starts to flash in the lower left of the display. Then, use the “” key to cycle through the available options. User is able to manually set the out output to be energized from 0-100% of the cycle time.

“Hx.xx” is used to adjust output 1.

“Cx.xx” is used to adjust output 2.

You are able to exit manual mode by pressing and holding the  key.

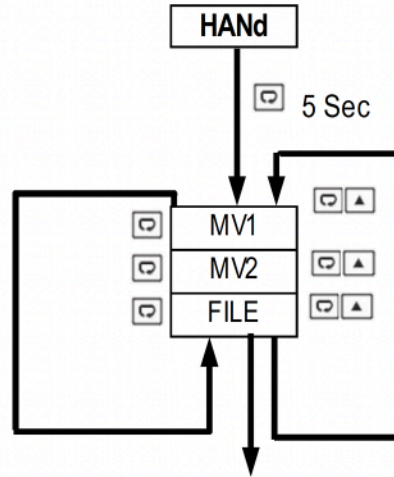



Press  key 5 Sec To execute the selected default program

### 1.1.4 Auto-Tuning Mode - Tunes PID Parameters to Your Application (See Pg. 16)

**A-t**

Press and hold the “” key for approx. 7sec until the “A-T” parameter is shown in the upper display.

Press and hold the “” key for 5 seconds to activate Auto-Tuning Mode. Continue to hold the “” key for an additional 3 seconds, else the display will revert to a “User Menu” parameter.

Auto-tuning allows the controller to find its own optimal control parameters (PID) by measuring the speed of your thermal process.

## 1.2 Parameter Description

(\*Parameters that are not applicable are not shown)

Register Address	Parameter Notation	Parameter Description	Range	Default Value
0	SP1	Set Point 1 (Used for Output 1)	Low: SP1L High: SP1H	77.0°F (25°C)
8	INPT	Input sensor selection Preset for this application	<b>0 J_tC:</b> J type Thermocouple <b>1 K_tC:</b> K type Thermocouple <b>2 T_tC:</b> T type Thermocouple <b>3 E_tC:</b> E type Thermocouple <b>4 B_tC:</b> B type Thermocouple <b>5 R_tC:</b> R type Thermocouple <b>6 S_tC:</b> S type Thermocouple <b>7 N_tC:</b> N type Thermocouple <b>8 L_tC:</b> L type Thermocouple <b>9 U_tC:</b> U type Thermocouple <b>10 P_tC:</b> P type Thermocouple <b>11 C_tC:</b> C type Thermocouple <b>12 D_tC:</b> D type Thermocouple <b>13 Pt.dN:</b> PT100 Ω DIN curve <b>14 Pt.JS:</b> PT100 Ω JIS curve <b>15 4-20:</b> 4-20mA linear current input <b>16 0-20:</b> 0-20mA linear current input <b>17 0-5V:</b> 0-5VDC linear voltage input <b>18 1-5V:</b> 1-5VDC linear voltage input <b>19 0-10:</b> 0-10VDC linear voltage input	1
9	UNIT	Input unit selection	<b>0 oC:</b> °C unit <b>1 oF:</b> °F unit <b>2 Pu:</b> Process unit	1
10	DP	Decimal point selection	<b>0 No.dP:</b> No decimal point <b>1 1-dP:</b> 1 decimal digit <b>2 2-dP:</b> 2 decimal digit <b>3 3-dP:</b> 3 decimal digit	0
13	SP1L	Low limit of set point 1 (Span Value)	Low: -19999 High :SP1H	0.0° F (-18.0°C)
14	SP1H	High limit of set point 1 (Span Value) Lower if needed to protect process	Low: SP1L High: 45536	1000.0°F (538.0°C)
15	FILT	Filter damping time constant of PV (See Pg. 15)	<b>0 0:</b> 0 second time constant <b>1 0.2:</b> 0.2 second time constant <b>2 0.5:</b> 0.5 second time constant <b>3 1:</b> 1 second time constant <b>4 2:</b> 2 second time constant <b>5 5:</b> 5 second time constant <b>6 10:</b> 10 second time constant <b>7 20:</b> 20 second time constant <b>8 30:</b> 30 second time constant <b>9 60:</b> 60 second time constant	2

Basic  
Menu

(\*Parameters that are not applicable are not shown)



Register Address	Parameter Notation	Parameter Description	Range	Default Value	
Basic Menu ↓	16	DISP	Secondary display selection	<b>0 None:</b> No Display <b>1 MV1:</b> Display MV1 <b>2 MV2:</b> Display MV2 <b>3 tIMR:</b> Display Dwell Time <b>4 PRoF:</b> display Profile Status	0
	17	PB	Proportional band value (See Pg. 17) Set this to 0 for valves	Low: 0.0 High: 900.0°F (500.0°C)	18.0° F (10.0° C)
	18	TI	Integral time value (See Pg. 17)	Low: 0 High: 3600 sec	100
	19	TD	Derivative time value (See Pg. 17)	Low: 0.0 High: 360.0 sec	25
Output Menu ↓	20	OUT1	Output 1 function	<b>0 REVR:</b> Reverse (heating) control action <b>1 dIRt:</b> Direct (cooling) control action	0
	21	O1TY FACTORY SET, DO NOT CHANGE	Output 1 signal type	<b>0 RELY:</b> Relay output <b>1 SSrd:</b> Solid state relay drive output <b>2 4-20:</b> 4-20mA linear current <b>3 0-20:</b> 0-20mA linear current <b>4 0-5V:</b> 0-5VDC linear voltage <b>5 1-5V:</b> 1-5VDC linear voltage <b>6 0-10:</b> 0-10VDC linear voltage	0
	22	O1FT	Output 1 failure transfer mode	Select BPLS (Bumpless transfer), or 0.0 ~ 100.0 % to continue output 1 control function if the sensor fails, or select OFF (0) or ON (1) for ON-OFF control	0
	23	O1HY	Output 1 ON-OFF control hysteresis (Use only if PB=0)	Low: 0.1°C (0.2°F) High: 50.0°C (90.0°F)	0.2 °F (0.1° C)
	24	CYC1	Output 1 cycle time	Low: 0.1 High: 90.0 sec.	18
Basic Menu ↑	26	RAMP	Ramp function selection	<b>0 NoNE:</b> No Ramp Function <b>1 MINR:</b> Use °/minute as Ramp Rate <b>2 HRR:</b> Use °/hour as Ramp Rate	0

\* Not used in this design

(\*Parameters that are not applicable are not shown)

	Register Address	Parameter Notation	Parameter Description	Range	Default Value
Basic Menu	27	RR	Ramp rate (See Pg. 13)	Low: 0.0 High: 900.0°F	0
Output Menu	61	PL1L	Output 1 Low Power limit	Low: 0 High: PL1H or 50%	0
	62	PL1H	Output 1 High Power limit	Low: PL1L High: 100 %	100
User Menu	94	PASS	Password entry (See Next Page)	Low: 0 High: 9999	0
Basic Menu	95	CODE	Security code for parameter protection (See Next Page)	Low: 0 High: 9999 0 = unprotected 1000 = user mode unprotected 9999 = SPx(1 to 7) unprotected	0
	96	OFTL	Offset value for low point calibration (See Pg. 14)	Low: -1999 High: 1999	0
	97	OFTH	Offset value for high point calibration (See Pg. 14)	Low: -1999 High: 1999	0
	98	CALO	Input signal value during low point calibration (See Pg. 14)	Low: -19999 High: CAHI-1	0
	99	CAHI	Input signal value during high point calibration (See Pg. 14)	Low: CALO+1 High: 45536	1000

## 2. PROGRAMMING

Press and hold  for 5 seconds, then release to enter the setup menu. Press and release  to cycle through the list of parameters. The upper display indicates the parameter symbol, and the lower display indicates the value of the selected parameter.

### 2.1 User Security

There are two parameters, PASS (password) and CODE (security code), which will control the lockout program.

CODE Value	PASS Value	Access Rights
0	Any Value	All parameters are changeable
1000	=1000	All parameters are changeable
	≠1000	Only user menu parameters changeable
9999	=9999	All parameters are changeable
	≠9999	Only SP1 to SP7 are changeable
Others	=CODE	All parameters are changeable
	≠CODE	No parameters can be changed

#### **2-1. User Access Rights**

### 2.2 Signal Input

**INPT:** Select the desired sensor type or signal type for the signal input. Factory Set.

**DO NOT CHANGE**

**UNIT:** Select the desired process unit

**Options:** °C, °F, PU (Process unit). If the unit is neither °C nor °F, then is set to PU.

**DP:** Select the desired resolution (decimal points) for the process value.

## 2.3 Control Output

There are 4 kinds of control modes can be configured as shown below.

### 2.3.1 Heat Only ON-OFF Control – (Used for Solenoids and Valves)

Select REVR for OUT1, Set PB to 0. O1HY is used to adjust the hysteresis for ON-OFF control. The output 1 hysteresis (O1HY) setting is only available when PB = 0. The heat only ON-OFF control function is shown below.

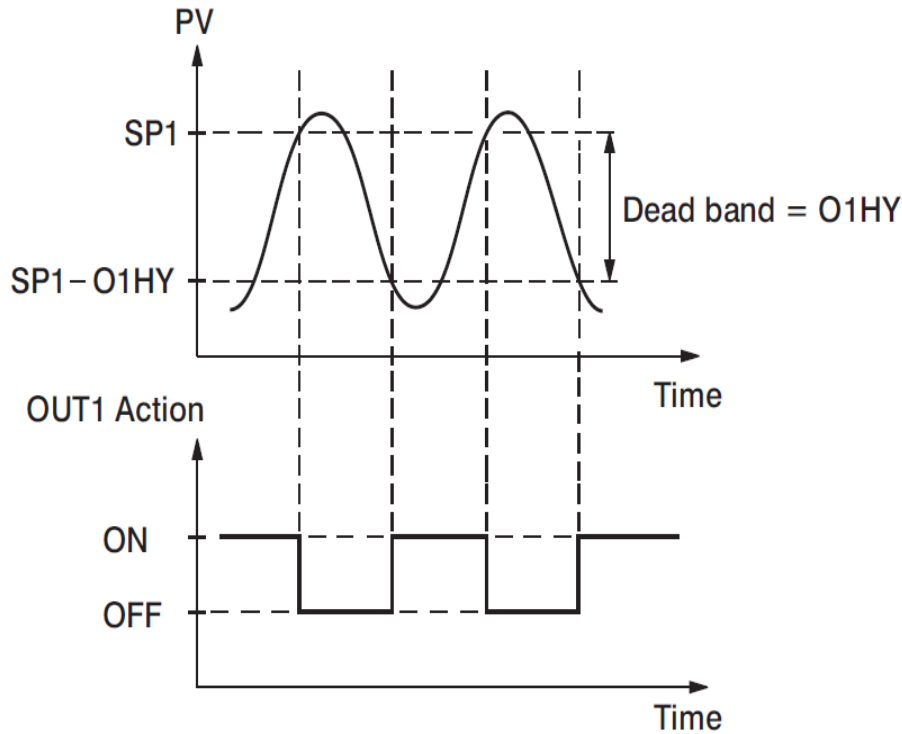

#### **2-1. Heat Only ON-OFF Control**

### 2.3.2 Heat only P or PD Control – (Used for Electric Heaters)

Select REVR for OUT1, set TI = 0, OFST is used to adjust the control offset (manual reset). If PB  $\neq$  0 then O1HY will be hidden.

**OFST Function:** OFST is measured in % with a range of 0 - 100.0 %. When the process is stable, let's say the process value is lower than the set point by 5°F. Let's also say that 20.0 is used for the PB setting. In this example, 5°F is 25% of the proportional band (PB).

By increasing the OFST value by 25%, the control output will adjust itself, and the process value will eventually coincide with the set point.

When using Proportional (P) control (TI = 0), Auto-Tuning will be unavailable. Refer to the "manual tuning" section for the adjustment of PB and TD. Manual reset (OFST) is usually not practical because the load may change from time to time; meaning the OFST setting would need to be constantly adjusted. PID control can avoid this problem.

### 2.3.3 Heat only PID Control – (Default for Electric Heaters)

Select REVR for OUT1. PB and TI should not be zero. Perform Auto-Tuning for initial startup. If the control result is not satisfactory, use manual tuning or try Auto-Tuning a second time to improve the control performance.

### 2.3.4 Cool only Control

ON-OFF control, Proportional control, and PID control can be used for cooling control. Set “OUT1” to DIRT (direct action).

**NOTE:** ON-OFF control may result in excessive overshoot and undershoot in the process. Proportional control could result in a deviation of the process value from the set point. It is recommended to use PID control for Heating or Cooling control to produce a stable process value.

When selecting parameters, all of the above parameters may not be available. The number of visible parameters depends on the configuration of the controller.

## 2.4 Ramp

The ramping function is performed during power up or any time the set point is changed. Choose “MINR” (ramp in minutes) or “HRR” (ramp in hours) for the “RAMP” setting, and the controller will perform the ramping function. The ramp rate is programmed by adjusting the “RR” setting. The ramping function is disabled whenever the controller enters Failure mode, Manual control mode, Auto-Tuning mode or Calibration mode.

### 2.4.1 Ramping Example without Dwell Timer

Set the “RAMP” setting to “MINR” to ramp in minutes.

Set the ramp rate (RR) to 10.

The starting temperature is 30°C.

The setpoint is initially set to 200°C.

After the process warms up, the user changed the setpoint to 100°C after 30 minutes.

After power up, the process will behave as shown below.

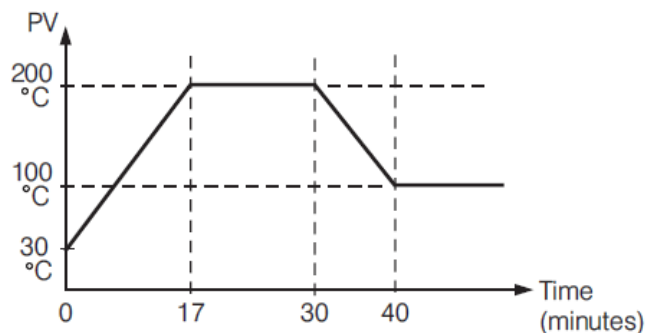

### 2-2. Ramp Function

**Note:** When the ramp function is used, the lower display will show the current ramping value. However, it will revert to show the set point value as soon as the up or down key is touched for adjustment. The ramp rate is initiated at power on and/or whenever the Set point is changed. Setting the “RR” setting to zero means no ramping function is used.

## 2.5 User Calibration - Display Offset







Each unit is calibrated in the factory before shipment. The user can still modify the calibration in the field.

The basic calibration of the controller is highly stable and set for life. User calibration allows the user to offset the permanent factory calibration in order to:

- Calibrate the controller to meet a user reference standard.
- Match the calibration of the controller to that of a particular transducer or sensor input.
- Calibrate the controller to suit the characteristics of a particular installation.
- Remove long term drift in the factory set calibration.

There are two parameters: Offset Low (OFTL) and Offset High (OFTH) for adjustment to correct an error in the process value.

There are two parameters for the sensor input. These two signal values are CALO and CAHI. The input signal low and high values are to be entered in the CALO and CAHI parameters respectively.

Refer to page 3 for key operation and page 10 for the operation flowchart. Press and hold the  key until the setup Menu page is obtained. Then, press and release the  key to navigate to the calibration low parameter OFTL. Send your low signal to the sensor input of the controller, then press and release the  key. If the process value (the upper display) is different from the input signal, the user can use  and  keys to change the OFTL value (the lower display) until the process value is equal to the value the user needs. Press and hold the  key for 5 seconds to complete the low point calibration (the display should blink once). The same procedure is applied for high scale calibration.

As shown below, the two points OFTL and OFTH construct a straight line. For the purpose of accuracy, it is best to calibrate with the two points as far apart as possible. After the user calibration is complete, the input type will be stored in the memory. If the input type is changed, a calibration error will occur and an error code `ERR` is displayed.

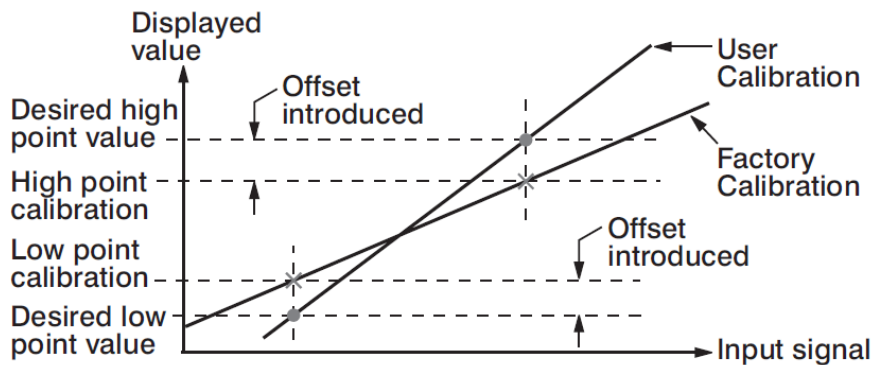

**2-3. Two Point User Calibration**

## 2.6 Digital Filter

In certain applications the process value is too unstable to be read. To improve this, a programmable low pass filter incorporated in the controller can be used. This is a first order filter with a time constant specified by the FILT parameter. A value of 0.5 seconds is used as a factory default. Adjust FILT to change the time constant from 0 to 60 seconds. 0 seconds represents no filter applied to the input signal. The filter is characterized by the following diagram.

**Note:** The Filter is available only for the process value (PV), and is performed for the displayed value only. The controller is designed to use an unfiltered signal for control even when a filter is applied. If a lagged (filtered) signal is used for control; it may produce an unstable process.

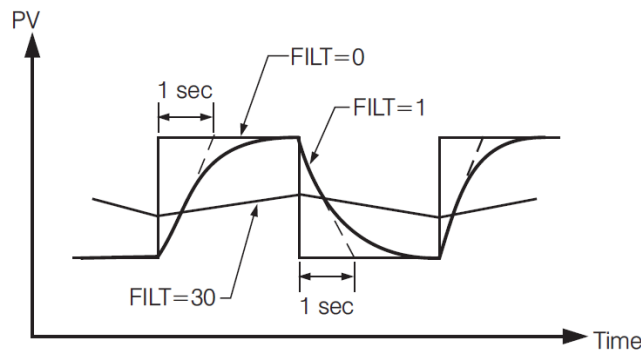

### 2-4. Filter Characteristics

## 2.6 Failure Transfer

The controller will enter failure mode if one of the following conditions occurs:

1. An SBER error occurs due to an input sensor break, an input current below 1mA for 4-20mA, or an input voltage below 0.25V for 1-5 V.
2. An ADER error occurs due to the A-D converter failing.

Output 1 and Output 2 will perform the failure transfer (O1.ft & O2.ft) function as the controller enters failure mode.

### 2.6.1 Output 1 Failure Transfer

If Output 1 Failure Transfer is activated, it will perform as follows:

1. If output 1 is configured as proportional control ( $PB \neq 0$ ), and BPLS is selected for O1FT, then output 1 will perform a Bumpless transfer. After that, the previous average value of the output will be used for controlling output 1.
2. If output 1 is configured as proportional control ( $PB \neq 0$ ), and a value of 0 to 100.0 % is set for O1FT, then output 1 will perform failure transfer. After that the value of O1FT will be used for controlling output 1.
3. If output 1 is configured as ON-OFF control ( $PB = 0$ ), then output 1 will transfer to an off state if OFF is set for O1FT, or it will transfer to an on state if ON is set for O1FT.





## 2.7 Auto-Tuning

 The Auto-Tuning process will be performed at the set point (SP1). The process will oscillate around the set point during the tuning process. Set a set point to a lower value if overshooting beyond the normal process value will cause damage. It is usually best to perform Auto-Tuning at the Set point the machine is expected to be operated at, with the process running normally (i.e. material in the oven, etc.).

Auto-Tuning is generally applied in the following cases:

- Initial setup for a new process.
- The set point is changed substantially from the previous Set point when Auto-Tuning was performed.
- The control result is unsatisfactory.

### 2.7.1 Auto-Tuning Operation Steps

1. The system is set up to run under real-world conditions.
2. “PB and “TI” settings should not be set to zero.
3. The LOCK parameter should be set to NONE.
4. Set the set point to a normal operating value, or a lower value if overshooting beyond the normal process value will cause damage.
5. Press and hold the  key until  appears on the upper display. Continue to hold the “” key for an additional 3 seconds, else the display will revert to a “User Menu” parameter.
6. Press and hold the  key until the TUNE indicator begins to flash.
7. The Auto-Tuning process has begun.

**NOTE:** During Auto-Tuning, the output will stay on until the Process Value reaches the setpoint. This is likely to cause the temperature to exceed the setpoint.

Then, the output will remain off until the process value falls below the setpoint.

This will occur at least two times while the controller “learns” how to control your process.

#### Procedures:



Auto-Tuning can be applied either as the process is warming up (Cold Start) or as the process has been in steady state (Warm Start). After the Auto-Tuning process is completed, the TUNE indicator will stop flashing and the unit will revert to PID control by using its new PID values. The PID values obtained are stored in nonvolatile memory.

### 2.7.2 Auto-Tuning Error

If Auto-Tuning fails, an ATER  message will appear on the upper display in any of the following cases.

- If PB exceeds 9000 ( 9000 PU, 900.0°F or 500.0°C )
- If TI exceeds 1000 seconds
- If the set point is changed during the Auto-Tuning process

### 2.7.3 Solution for an Auto-Tuning Error

1. Try Auto-Tuning once again.
2. Avoid changing the set point value during the Auto-Tuning process.
3. Ensure PB and TI are not set to zero.
4. Use manual tuning.
5. Touch RESET  key to reset the  message.

## 2.8 Manual Tuning

In certain applications, using Auto-Tuning may be inadequate for the control requirement, or, the process moves too slowly to Auto-tune accurately.

If this is the case, the user can try manual tuning.

If the control performance by using Auto-Tuning is still unsatisfactory, the following guidelines can be applied for further adjustment of PID values.

ADJUSTMENT SEQUENCE	SYMPTOM	SOLUTION
Proportional Band ( PB )	Slow Response	Decrease PB
	High overshoot or Oscillations	Increase PB
Integral Time ( TI )	Slow Response	Decrease TI
	Instability or Oscillations	Increase TI
Derivative Time ( TD )	Slow Response or Oscillations	Decrease TD
	High Overshoot	Increase TD



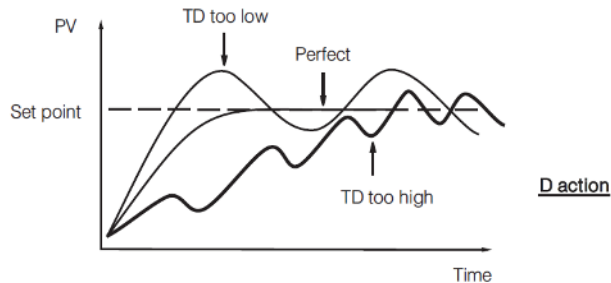
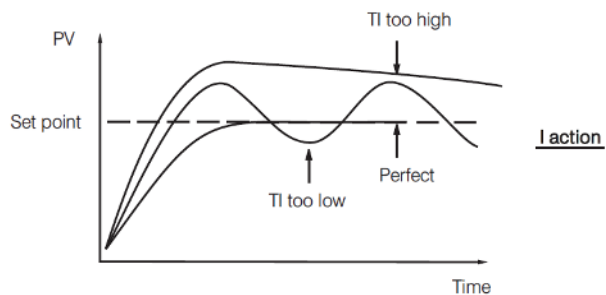
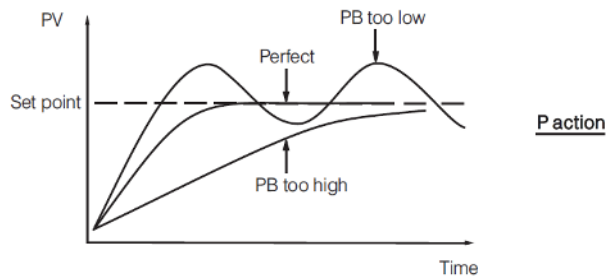

### 2-2. PID Parameter Adjustment Guide





### 2-5. Effects of PID Adjustment

## 2.9 Manual Control

To enable manual control, ensure the LOCK parameter is set to NONE.

Press and hold  until  (Hand Control) appears on the display. Press and hold  until the “MANU” indicator begins to flash. The lower display will show .

 Indicates the output control variable for output 1, and  indicates the control variable for output 2. The user can use the up-down keys to adjust the percentage values for the heating or cooling output. This % value is based on the CYC1 and CYC2 settings, where the associated output will stay on for the % of time the CYC1 & CYC2 values are set for.

Example: If CYC1 is set to 20 seconds, and the controller is set to “H50.0”, the output will be on for 10 seconds, then turn off for 10 seconds.





The controller performs open loop control and ignores the input sensor as long as it stays in manual control mode.

### 2.9.1 Exit Manual Control

Pressing the  key will revert the controller to its normal display mode.

## 2.10 Setting Controller to Factory Default

The controller’s parameters can be loaded with default values listed in the parameter description table. In certain situations it is desirable to retain these values after the parameters values has been changed. The below procedure to be followed to reload the default values.

1. Ensure the LOCK parameter is set to NONE.
2. Press and hold  until  (Hand Control) appears on the display.
3. Press and release the  key to cycle through the manual mode menu to reach “FILE”.
4. Press and hold  for 5 seconds or until the upper display FILE flash for a moment.

## 2.11 Error Codes for TEC-9400 Controller

Error Code	Display Symbol	Description & Reason	Corrective Action
4	ER04	<b>Illegal setup values used:</b> COOL is used for OUT2 when DIRT (cooling action) is used for OUT1, or when PID mode is not used for OUT1 (PB=0 and/or TI=0)	Check and correct setup values of OUT2, PB1, PB2, TI1, TI2 and OUT1. IF OUT2 is needed for cooling control, the controller should use PID mode (PB≠0 and TI≠0) and OUT1 should use reverse mode (heating action), otherwise, OUT2 cannot be used for cooling control.
10	ER10	<b>Communication error:</b> bad function code	Correct the communication software to meet the protocol requirements.
11	ER11	<b>Communication error:</b> register address out of range	Do not issue an over-range address of the register to the secondary.
14	ER14	<b>Communication error:</b> attempt to write a read-only data	Do not write read-only data or protected data to the secondary.
15	ER15	<b>Communication error:</b> write a value which is out of range to a register	Do not write an over-range data to the secondary register.
16	EIER	<b>Event Input Error:</b> Two or more event inputs are set to the same function	Do not set the same function in two or more Event Input Function parameters (E1FN through E6FN).
26	ATER	<b>Auto-Tuning Error:</b> Failed to perform Auto-Tuning function	<ol style="list-style-type: none"> <li>1. The PID values obtained after Auto-Tuning process are out of range. Retry Auto-Tuning.</li> <li>2. Do not change the set point value during Auto-Tuning process.</li> <li>3. Use manual tuning instead of Auto-Tuning process.</li> <li>4. Do not set a zero value for TI.</li> <li>5. Do not set a zero value for PB.</li> <li>6. Touch RESET key.</li> </ol>
29	EEPR	EEPROM can't be written correctly	Return to factory for repair.
30	CJER	Cold junction compensation for Thermocouple malfunction	Cannot be repaired.
39	SBER	Input sensor break, or input current below 1 mA if 4-20 mA is used, or input voltage below 0.25V if 1 - 5V is used	Cannot be repaired.
40	ADER	A to D converter or related component(s) malfunction	Cannot be repaired.



# TEMPCO®

## USER MANUAL

### TEC-460/960/6600 Limit Controller





# 1 INTRODUCTION

## 1.1 Introduction

The TEC-960 is a FM Approved limit controller that can be configured either as a high limit or low limit controller by the user. This limit controller is powered by 90-250 VDC / VAC supply and incorporating a 2-amp mechanical dry-contact relay output. The input signal is digitized by using an 18-bit A to D converter. It's fast-sampling rate allows the limit controller to protect fast processes.

## 1.2 Features

The unique features are listed below, some optional:

- LCD Display (using NFPA79 & IEC Standard Colors)
- High Accuracy 18 Bit A-D Conversion and 15 Bit D-A Conversion
- Fastest Sampling Rate of 200 MS
- Alarm silence feature - press "R" once
- Lockout Protection
- Bidirectional Menu Navigation
- In Field Calibration - User Offset
- °C / °F Temperature Ranges / Process Units
- Configurable display logic - SAFE

## 1.3 Limit Control Function

When a temperature controller is controlling the temperature of a furnace or other heating device, a malfunction in that temperature controller may cause the furnace temperature to rise, resulting in damage to the heated product or the furnace itself and possibly injury and death. When this situation occurs with the Limit controller, if the temperature rises above the pre-set limit temperature (Heating Application), the limit output will open and the heater system circuit can be shut down to stop the heat source. In addition, the limit output will remain open even when the temperature returns to the normal range. The limit output will remain open until it is reset manually by pressing the "R" button again.

With the Limit Controllers, it is possible to establish a lower limit instead of an upper limit so that the limit function operates when the temperature falls below the limit setting value (Cooling Application). When an input error occurs, the limit output will open and will remain in this condition until the sensor error is fixed and a reset is provided.

### 1.3.1 High Limit Control

If Hi. is selected for OUT1, the unit will perform high limit control. When power is applied the OUT1 relay is de-energized. After 6.5 seconds self-test period, if the process is below the high limit set point (HSP1), the output 1 relay will be energized and OUT1 indicator will go off. If the process goes above the high limit set point, the relay will be de-energized, the OUT1 indicator will go on and the display will show the process value. After the process falls below the high limit set point and the reset  key is pressed or the remote reset input is applied, the relay will be energized and the OUT1 indicator will go off.

### 1.3.2 Low Limit Control

If Lo. is selected for OUT1, the unit will perform low limit control. When power is applied the OUT1 relay is de-energized. After 6.5 seconds self-test period, if the process is above the low limit set point (LSP1), the output 1 relay will be energized and OUT1 indicator will go off. If the process goes below the low limit set point, the relay will be de-energized, the OUT1 indicator will go on and the display will show the process value. After the process falls below the high limit set point and the reset  key is pressed or the remote reset input is applied, the relay will be energized and the OUT1 indicator will go off.

### 1.3.3 High/Low Limit Control

If Hi. Lo is selected for OUT1, the unit will perform high/low limit control. When power is applied the OUT1 relay is de-energized. After 6.5 seconds self-test period, if the process is below the high limit set point (HSP1) and above the low limit set point (LSP1), the output 1 relay will be energized and OUT1 indicator will go off. If the process goes above the high limit set point or below the low limit set point, the relay will be de-energized, the OUT1 indicator will go on and the display will show the process value. After the process is within the normal operation range, and the reset  key is pressed or the remote reset input is applied, the relay will be energized and the OUT1 indicator will go off.

### 1.3.4 Using Limit Control Function

When the measured temperature (PV) exceeds the limit setting value, the limit output relay opens and the OUT1 operation indicator turns ON. If the limit output relay opens (limit alarm is ON), the limit output relay will remain open until the operator checks operation (performs resetting operation).

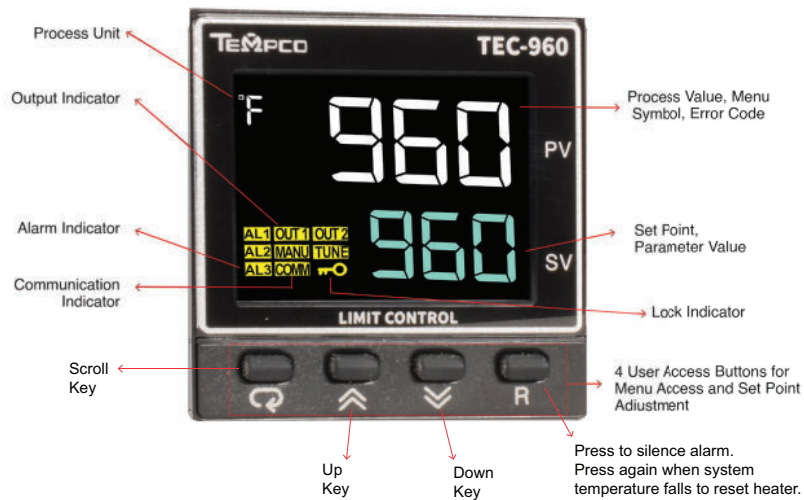

### 1-4 TEC-960 Front Panel Keys and Display

## 1.4 Keys and Displays

### KEYPAD OPERATION

#### SCROLL KEY:

This key is used to select a parameter to be viewed or adjusted and navigate to the next parameter.

#### ENTER KEY:

Press and hold for 5 seconds or longer to:

1. Enter the setup menu. The display will show . Press and hold for 8.6 seconds, then let go to select calibration mode.
2. Perform calibration of a selected parameter during the calibration procedure. The display will show .

#### UP KEY:

This key is used to increase the value of the selected parameter.

#### DOWN KEY:

This key is used to decrease the value of the selected parameter.

#### RESET KEY:

This key is used to:

1. Revert the display to the home screen.
2. Reset a latching alarm once the alarm condition is removed.
3. Reset the limit condition after the process is within the limit.
4. Reset the limit annunciator - Silence Alarm

Note: If the RESET key is left pressed, only ONE reset operation will occur. If the unit subsequently goes into a state where reset is required again, the RESET key (or remote reset contacts) must be released (opened) and pressed (closed) again.

**POWER UP SEQUENCE:**

During power up the following sequence will be followed.

1. All segments of display and indicators are left off for 4 second.
2. All segments of display and indicators are lit for 1.5 seconds.
3. The upper display will show PROG and the lower display will show the Firmware version for 1.5 seconds.

**NORMAL DISPLAY:**

During normal operation, the unit will display the process value, and the word SAFE.

**ABNORMAL DISPLAY:**

Whenever the process is outside the normal range, the lower display will display the limit set point value instead of displaying the word SAFE.

**SENSOR BREAK DISPLAY:**

If a sensor break is detected in the sensor circuit, the display will show: SBER

**A-D FAILURE DISPLAY:**

If failure is detected in the A-D converter circuit, the display will show ADER

## 1.5 Menu Flowchart

The Menu has been divided into 3 groups. They are as follows:

1. User Menu - Below
2. Setup Menu - Pg. 29
3. Calibration Mode Menu

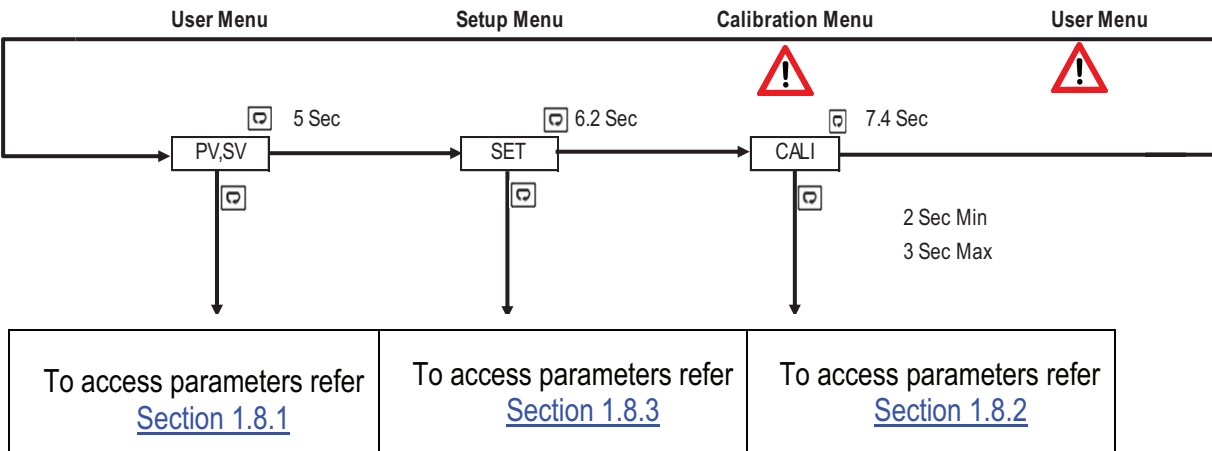

Press for the next parameter

Press and key to return to the previous parameter

### 1.5.1 User Menu

The below user menu parameters are available for easy user access depends on the selection in the user menu configuration. The upper display will show the parameters and the lower display will show its selection.

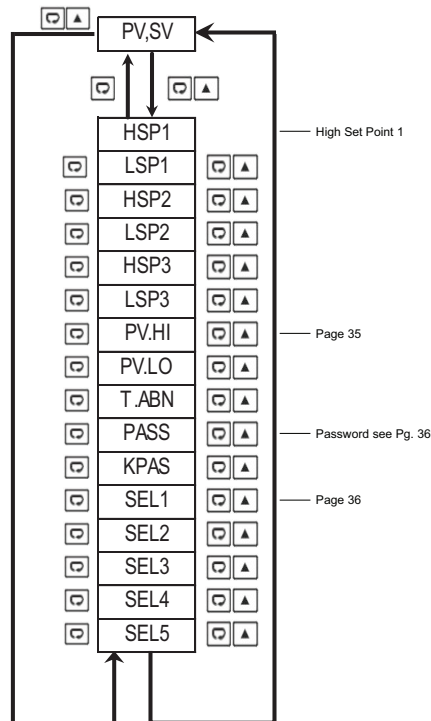

**Note Pg. 46  
for TEC-960  
Error Codes**

### 1.5.2 Calibration Menu - **Warning May Void Warranty**

Press  key for 2 seconds or longer (not more than 3 seconds) then release it to enter calibration Mode. KPAS = KCOD for entering to calibration mode.

Press  Key for 5 seconds to perform calibration.

Note:

- Calibration modes will break the limit loop and change some of the previous setting data. Make sure that the system is allowable to apply these modes.
- The flow chart shows a complete list of all parameters. For actual application, the number of available parameters will vary depending on the setup and model of the limit controller and will be less than that shown in the flow chart.

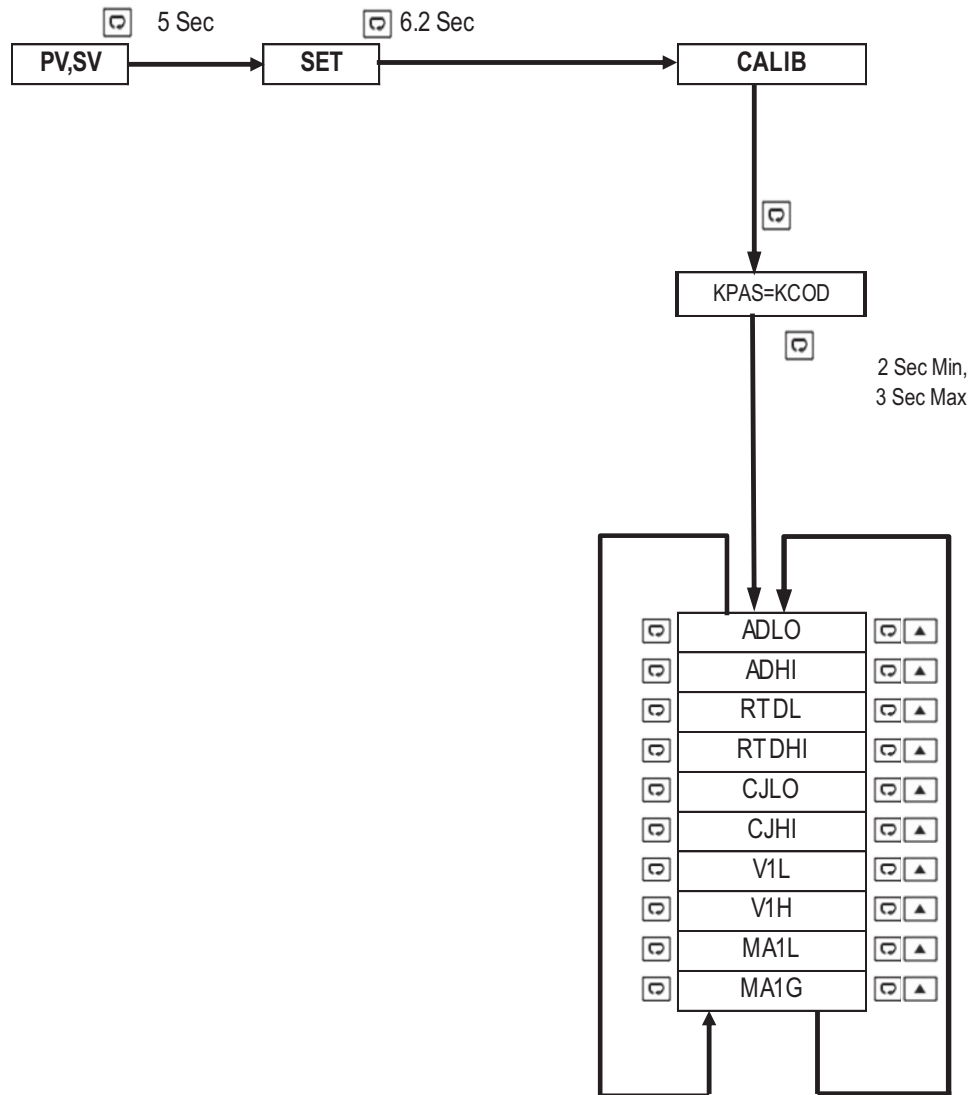

### 1.5.3 Setup Menu

The setup menu has been categorized into six categories for easy user access. They are listed as below.

- |                         |                         |
|-------------------------|-------------------------|
| 1. Basic Menu - Below   | 4. Event Input Menu *   |
| 2. Output Menu - Pg. 30 | 5. User Select Menu     |
| 3. Alarm Menu - Pg. 30  | 6. Communication Menu * |

#### 1.8.3.1 Basic Menu (bASE)

Once get SET in the upper display, use  $\uparrow$  or  $\downarrow$  key to get bASE in the lower display then use key to access to basic menu parameters. The upper display will show the parameters and the lower display will show its selection.

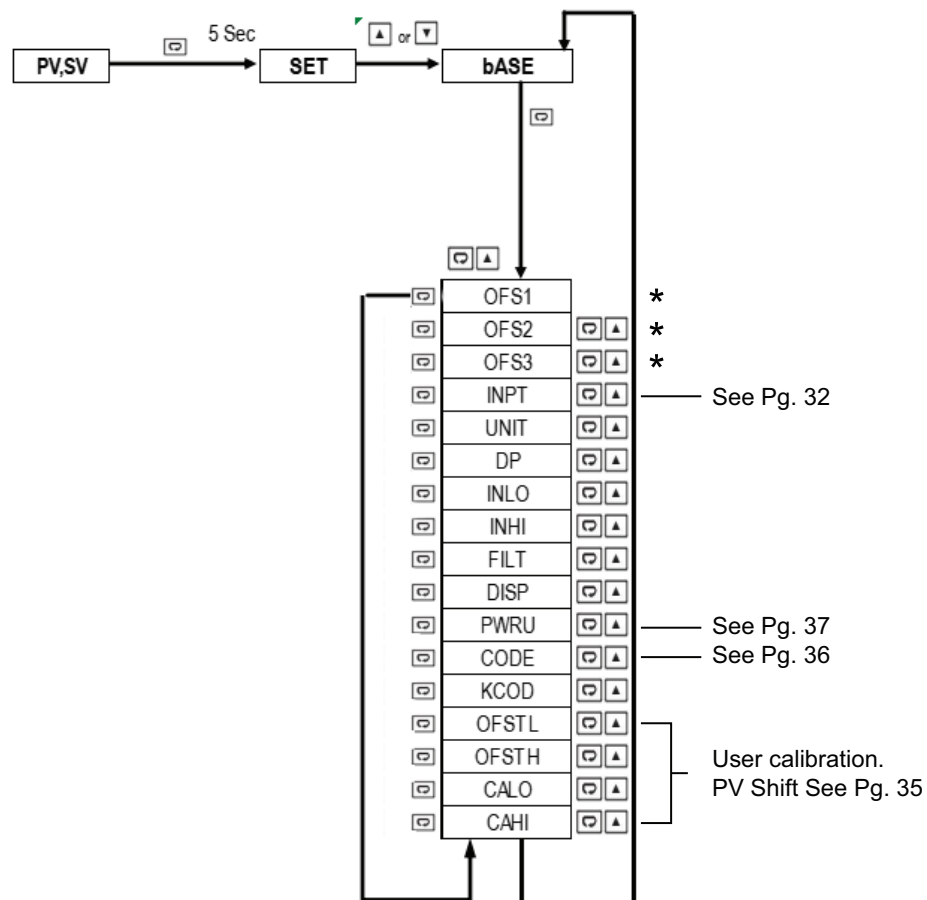

**\* Not used in this design**

### 1.5.3.2 Output Menu (OUT)

Once get SET in the upper display, use  $\uparrow$  or  $\downarrow$  key to get OUT in the lower display then use key to access to output parameters. The upper display will show the parameters and the lower display will show its selection.

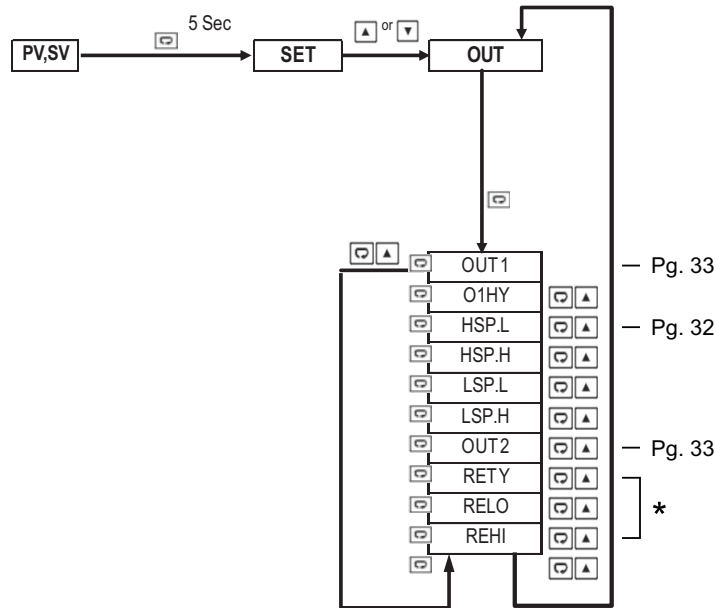

### 1.5.3.4 Alarm Menu (ALRM)

Once get SET in the upper display, use  $\uparrow$  or  $\downarrow$  key to get ALRM in the lower display then use key to access to alarm parameters. The upper display will show the parameters and the lower display will show its selection.

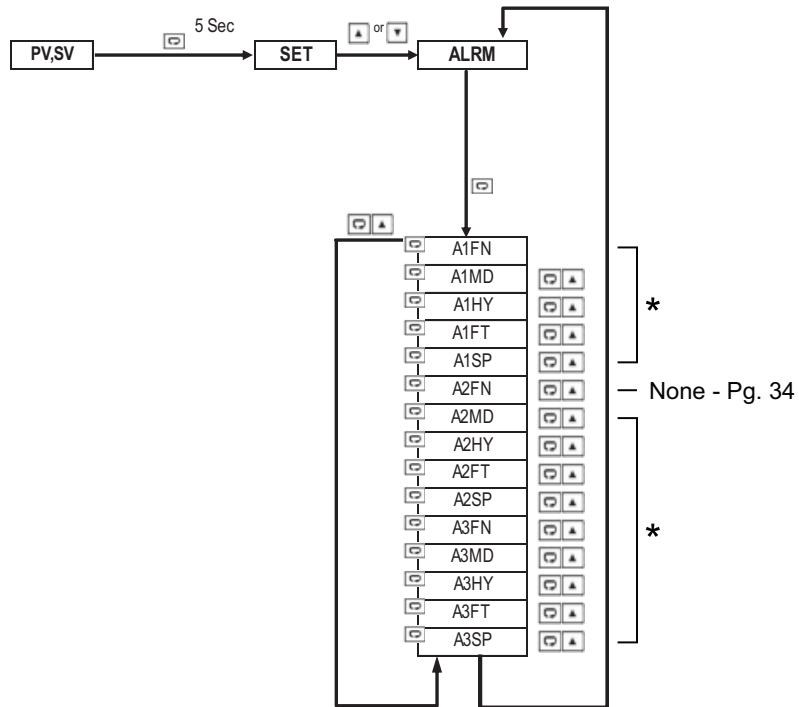

**\*Not used in this design**

### 1.5.3.6 User Menu (SEL)

Once get SET in the upper display, use  $\uparrow$  or  $\downarrow$  key to get SEL in the lower display then use key to access to user menu parameters. The upper display will show the parameters and the lower display will show its selection.

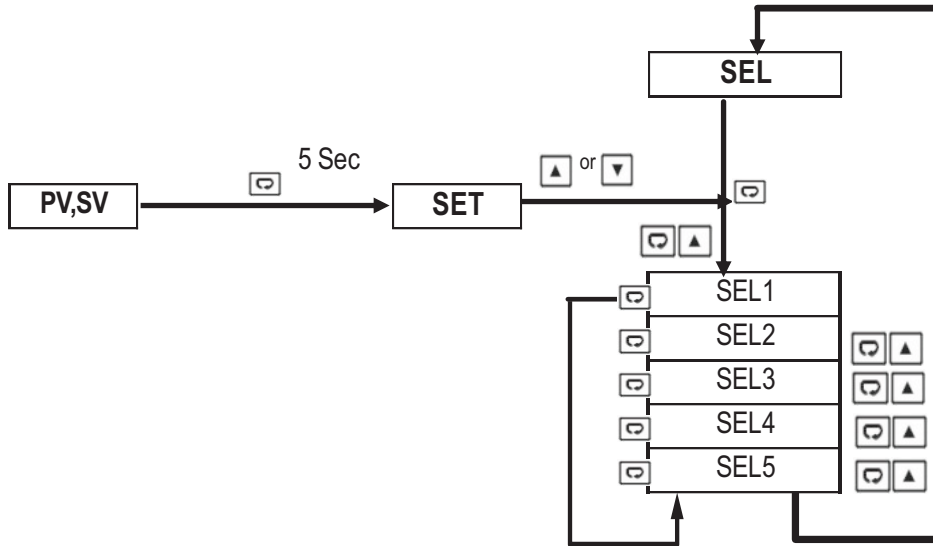

## 1.6 Parameters Description

Modbus Register Address	Parameter Notation	Parameter Description	Range	Default Value	Scale	
					Low	High
0	HSP1	High Limit Set Point 1	Low: HSPL High: HSP.H	212°F (100°C)	-19999	45536
1	LSP1	Low Limit Set Point 1	Low: LSPL High: LSP.H	32°F (0°C)	-19999	45536
2	HSP2	High Limit Set Point 2	Low: -19999 High: 45536	230°F (110°C)	-19999	45536
3	LSP2	Low Limit Set Point 2	Low: -19999 High: 45536	14°F (-10°C)	-19999	45536
4	HSP3	High Limit Set Point 3	Low: -19999 High: 45536	194°F (90°C)	-19999	45536
5	LSP3	Low Limit Set Point 3	Low: -19999 High: 45536	-58°F (-50°C)	-19999	45536
6	INPT	Input sensor selection (Pg. 29)	<b>0 J_tC:</b> J type Thermocouple <b>1 K_tC:</b> K type Thermocouple <b>2 t_tC:</b> T type Thermocouple <b>3 E_tC:</b> E type Thermocouple <b>4 b_tC:</b> B type Thermocouple <b>5 R_tC:</b> R type Thermocouple <b>6 S_tC:</b> S type Thermocouple <b>7 N_tC:</b> N type Thermocouple <b>8 L_tC:</b> L type Thermocouple <b>9 U_tC:</b> U type Thermocouple <b>10 P_tC:</b> P type Thermocouple <b>11 C_tC:</b> C type Thermocouple <b>12 d_tC:</b> D type Thermocouple <b>13 Pt. dN:</b> PT100 Ω DIN curve <b>14 Pt.JS:</b> PT100 Ω JIS curve <b>15 4-20:</b> 4-20mA linear current <b>16 0-20:</b> 0-20mA linear current <b>17 0-5V:</b> 0-5VDC linear voltage <b>18 1-5V:</b> 1-5VDC linear voltage <b>19 0-10:</b> 0-10VDC linear voltage <b>20 0-50:</b> 0-50mVDC linear voltage	1	0	65535
7	UNIT	Input unit selection (Pg. 39)	<b>0 oC:</b> °C unit <b>1 oF:</b> °F unit <b>2 Pu:</b> Process unit	1	0	65535
8	DP	Decimal point selection (Pg. 39)	<b>0 No. dP:</b> No decimal point <b>1 1-dP:</b> 1 decimal digit <b>2 2-dP:</b> 2 decimal digits <b>3 3-dP:</b> 3 decimal digits	0	0	65535
9	INLO	Input low scale value (Pg. 39)	Low: -19999 High: 45536	0°F (-17°C)	-19999	45536
10	INHI	Input high scale value (Pg. 39)	Low: -19999 High: 45536	200°F (93°C)	-19999	45536
11	HSPL	Low limit of high limit set point value (Pg. 39)	Low: -19999 High: HSPH	32°F (0°C)	-19999	45536

\* Not used in this application

	Modbus Register Address	Parameter Notation	Parameter Description	Range	Default Value	Scale		
						Low	High	
Output Menu	12	HSPH	High limit of high limit set point value	Low: HSPL High: 45536 (Pg. 39)	932°F (500°C)	-19999	45536	
	13	LSPL	Low limit of low limit set point value	Low: -19999 High: LSPH (Pg. 39)	148°F (-100°C)	-19999	45536	*
	14	LSPH	High limit of low limit set point value	Low: LSPL High: 45536 (Pg. 39)	32°F (0°C)	-19999	45536	*
Base Menu	15	FILT	Filter damping time constant of PV (Pg. 44)	<b>0 0:</b> 0 second time constant <b>1 0.2:</b> 0.2 second time constant <b>2 0.5:</b> 0.5 second time constant <b>3 1:</b> 1 second time constant <b>4 2:</b> 2 second time constant <b>5 5:</b> 5 second time constant <b>6 10:</b> 10 second time constant <b>7 20:</b> 20 second time constant <b>8 30:</b> 30 second time constant <b>9 60:</b> 60 second time constant	2	0	65535	
	16	DISP	Normal display format	<b>0 SAFE:</b> Display SAFE <b>1 HSP1:</b> Display HSP1 value <b>2 LSP1:</b> Display LSP1 value	1	0	65535	
Output Menu	17	OUT1	Output 1 function	<b>0 HI:</b> High Limit Control <b>1 LO:</b> Low Limit Control <b>2 HL:</b> High / Low Limit Control	0	0	65535	
	18	O1HY	Output Hysteresis	Low: 0.2°F (.1°C) High: 90°F (50°C)	.2°F (.1°C)	0	65535	
	19	OUT2	Output 2 function	<b>0 NoNE:</b> Output2 turned off <b>1 DCPS:</b> DC Power Supply <b>2 AL1:</b> Alarm 1 Function <b>3 L_An:</b> Limit Annunciator	3	0	65535	
Alarm Menu	20	A1FN	Alarm 1 function for alarm 1 output	<b>0 NoNE:</b> No alarm function <b>1 PV.HI:</b> Process value high alarm <b>2 PV. Lo:</b> Process value low alarm	2	0	65535	*
	21	A1MD	Alarm 1 operation mode	<b>0 NoRM:</b> Normal alarm action <b>1 LtCH:</b> Latching alarm action <b>2 NoR.R:</b> Normal alarm reverse action <b>3 LtC.R:</b> Latching alarm	0	0	65535	*
	22	A1HY	Alarm 1 Hysteresis control	Low: 0.2°F (.1°C) High: 90°F (50°C)	.2°F (.1°C)	0	65535	*
	23	A1FT	Alarm 2 failure transfer mode	<b>0 oFF:</b> Alarm output OFF if the sensor fails <b>1 oN:</b> Alarm output ON if the	1	0	65535	*
	24	A1SP	Alarm 1 set point	Low: -19999 High: 45536	212°F (100°C)	-19999	45536	*

\* Not used in this application

## 1.6 Parameters Description Continued

Modbus Register Address	Parameter Notation	Parameter Description	Range	Default Value	Data Access Type	Scale	
						Low	High
25	A2FN	Alarm 2 functions for alarm 2 outputs	Same as A1FN	2	R/W	0	65535
26	A2MD	Alarm 2 operation mode	Same as A1MD	0	R/W	0	65535
27	A2HY	Alarm 2 Hysteresis control	Low: (.1°C) High: 90°F (50°C)	.2°F (.1°C)	R/W	0	65535
28	A2FT	Alarm 2 failure transfer mode	<b>0 oFF:</b> Alarm output OFF if the sensor fails <b>1 oN:</b> Alarm output ON if the sensor fails	1	R/W	0	65535
29	A2SP	Alarm 2 set point	Low: -19999 High: 45536	212°F (100°C)	R/W	-19999	45536
30	A3FN	Alarm 3 functions for alarm 3 output	Same as A1FN	2	R/W	0	65535
31	A3MD	Alarm 3 operation mode	Same as A1MD	0	R/W	0	65535
32	A3HY	Alarm 3 Hysteresis control	Low: (.1°C) High: 90.0°F (50°C)	.2°F (.1°C)	R/W	0	65535
33	A3FT	Alarm 3 failure transfer mode	<b>0 oFF:</b> Alarm output OFF if the sensor fails <b>1 oN:</b> Alarm output ON if the sensor fails	1	R/W	0	65535
34	A3SP	Alarm 3 set point	Low: -19999 High: 45536	212°F (100°C)	R/W	-19999	45536
35	OFS1	Option 1	<b>0 NoNE:</b> Not selected	0	R/W	0	65535

Alarm Menu

Base Menu

\*

**\* Not used in this application**

Modbus Register Address	Parameter Notation	Parameter Description	Range	Default Value	Data Access Type	Scale	
						Low	High
* 38	E1FN	Event input 1 function	<b>0 NoNE:</b> none <b>1 LOCK:</b> Remote Lock <b>2 RRST:</b> Remote Reset <b>3 HSP2:</b> HSP2 activated to replace HSP1 <b>4 LSP2:</b> LSP2 activated to replace LSP1 <b>5 HLS2:</b> HSP2 & LSP2 activated to replace HSP1 & LSP1 <b>6 HSP3:</b> HSP3 activated to replace HSP1 <b>7 LSP3:</b> LSP3 activated to replace LSP1 <b>8 HLS3:</b> HSP3 & LSP3 activated to replace HSP1 & LSP1 <b>9 rS.A1:</b> Reset alarm 1 output <b>10 rS.A2:</b> Reset alarm 2 output <b>11 rS.A3:</b> Reset alarm 3 output <b>12 rS.Ao:</b> Reset all alarm outputs <b>13 13 CA.LH:</b> Cancel alarm latch <b>14 R.REF:</b> Reset Reference Data E1FN ≠ E2FN, except selects NONE	0	R/W	0	65535
* 39	E2FN	Event input 2 function	Same as E1FN E1FN ≠ E2FN, except selects NONE	0	R/W	0	65535
46	OFTL (Pg. 43)	Offset value of low point calibration	Low:-1999 High: 1999	0	R/W	-19999	45536
47	OFTH (Pg. 43)	Offset value of high point calibration	Low:-1999 High: 1999	0	R/W	-19999	45536
48	CALO (Pg. 43)	Input signal value during low point calibration	Low:-1999 High: CAHI-1 CALO ≠ CAHI	0	R/W	-19999	45536
49	CAHI (Pg. 43)	Input signal value during high point calibration	Low:CALO+1 High: 45536 CALO ≠ CAHI	1000	R/W	-19999	45536
63	T.ABN	Accumulated time during abnormal condition	Low:-1999 High: 65535 5 Minutes	-----	R	0	65535
67	PV.HI	Historical Maximum Value of PV	Low:-1999 High: 45536	-----	R	-19999	45536
68	PV.LO	Historical Minimum Value of PV	Low:-1999 High: 45536	-----	R	-19999	45536

**\* Not used in this application**

## 1.6 Parameters Description Continued

Modbus Register Address	Parameter Notation	Parameter Description	Range	Default Value	Data Access Type	Scale	
						Low	High
76	SEL1	1'st parameter for the user menu (Pg. 42)	<b>0</b> NoNE: No Parameter <b>1</b> dISP: DISP <b>2</b> o1HY: O1HY <b>3</b> A1HY: A1HY <b>4</b> A1SP: A1SP <b>5</b> A2HY: A2HY <b>6</b> A2SP: A2SP <b>7</b> OFTL: OFTL <b>8</b> OFTH: OFTH <b>9</b> CALO: CALO <b>10</b> CAHI: CAHI	0	R/W	0	65535
77	SEL2	2'nd parameter for the user menu	Same as SEL1	0	R/W	0	65535
78	SEL3	3'rd parameter for the user menu	Same as SEL1	0	R	0	45536
79	SEL4	4'th parameter for the user menu	Same as SEL1	0	R	0	65535
80	SEL5	5'th parameter for the user menu	Same as SEL1	0	R	0	45536
81							
82							
83							
84							
85	PASS	Password entry (See Pg. 38)	Low: 0 High: 9999 (Pg. 38)	0	R/W	-32768	32767
86	KPAS	Calibration password entry	Low: 0 High: 9999 (Pg. 38)	0	R/W	-32768	32767
87	CODE	Security code for parameter protection	Low: 0 High: 9999 (Pg. 38)	0	R/W	-32768	32767
88	KCOD	Security code for calibration protection	Low: 0 High: 9999 (Pg. 38)	0	R/W	-32768	32767
128	PV	Current process value	Low: -19999 High: 45536	-----	R	-19999	45536
129	HSV1	Current high limit set point value	Low: SP1L High: SP1H	-----	R	-19999	45536



User Menu

Base Menu

Modbus Register Address	Parameter Notation	Parameter Description	Range	Default Value	Data Access Type	Scale		
						Low	High	
130	LSV1	Current low limit set point value	Low: SP1L High: SP1H	-----	R	-19999	45536	
131	T.ABN	Accumulated time during abnormal condition	Low: 0.0 High: 6553.5 Minutes	-----	R	0	65535	
132	MODE	Operation mode & alarm status	Low: 0 High: 65535	-----	R	0	65535	
133	PWRU	Power-Up logic	<b>0 NoRM</b> :Normal <b>1 RST</b> : Reset <b>2 NoRL</b> : Normal Latch	0	R/W	0	65535	
134								
135								
136								
137								
138								
139	EROR	Error code	Low: 0 High: 65535	-----	R	0	65535	
140	PROG	Program code	<b>L42</b> : 45. XX <b>L62</b> : 64. XX <b>L22</b> : 26. XX	-----	R	0	65535	
141								
142	CMND	Command code	Low: 0 High: 65535	-----	R/W	0	65535	*
143	JOB1	Job code	Low: 0 High: 65535	-----	R/W	0	65535	*

**\* Not used in this application**

## 2 PROGRAMMING

Press  for 5 seconds and release to enter the setup menu. Press and release  to select the desired parameter. The upper display indicates the parameter symbol, and the lower display indicates the value of the selected parameter.

### 2.1 User Security

There are two parameters PASS (password) and CODE (security code) which will control the data security function.

CODE Value	PASS Value	Access Rights
0	Any Value	All parameters are changeable
500	=500	All parameters are changeable
	≠500	All parameters are changeable except calibration parameters
1000	=1000	All parameters are changeable
	≠1000	Only user menu parameters changeable
9999	=9999	All parameters are changeable
	≠9999	Only SP1 to SP7 are changeable
Others	=CODE	All parameters are changeable
	≠CODE	No parameters can be changed

#### **2-1 User Access Rights**

##### **Note:**

- If the user security is enabled, the controller will be automatically locked (logout) after a period of one minute idle time or when the power is disconnected. If the user needs to modify the parameters, then the user needs to configure PASS=CODE to login again.
- If the Remote Lock is function is used with event input, then the remote lock must be released to do changes on any of the parameters.
- The user needs to observe CODE, PASS logic for the remote lock operation. In addition, if remote is needed, it means the remote priority is higher than local. Local changes will be over-written by remote operations. If the code is equal to “0”, the remote LOCK feature won't work

### 2.2 Calibration Security

The calibration of the device is protected with separate security access. There are two parameters' KPAS (calibration password) and KCOD (calibration security code) which will control the data security of calibration parameters.

When KPAS = KCOD the user can modify the calibration parameters.

KCOD Value	KPAS Value	Access Rights
KCOD	=KCOD	Calibration parameters are changeable
	≠KCOD	Calibration parameters can't be changed

#### **2-2 Calibration Access Rights**

## 2.3 Signal Input

**INPT:** Set to Type K T/C

**UNIT:** Select the desired process unit

**Range:** °C, °F, PU (Process unit). If the unit is neither °C nor °F, then selects PU.

**DP:** Select the resolution of the process value

**Range:** For Thermocouple and RTD Signal NO.DP, 1-DP

## 2.4 Limit Control Output

Select the output 1 function and hysteresis in OUT1 and O1HY.

**OUT1:** The available output 1 functions are: High Limit Control, Low Limit Control and High & Low Limit Control. Refer to Section 1.3 for the limit control operation.

**O1HY:** Output 1 hysteresis value. The hysteresis value is adjusted to a proper value to eliminate the relay jitter in a noisy environment.

## 2.5 Set Point Range

The set point range can be configured with the following parameters.

**HSP.L :** Lower limit of high limit set point HSP1. Hidden if LO is selected for OUT1

**HSP.H :** Upper limit of high limit set point HSP1. Hidden if LO is selected for OUT1

**LSP.L :** Lower limit of low limit set point LSP1. Hidden if HI is selected for OUT1

**LSP.H :** Upper limit of low limit set point LSP1. Hidden if HI is selected for OUT1

HSP.L and HSP.H in setup menu are used to confine the adjustment range of high limit set point HSP1. LSP.L and LSP.H are used to confine the adjustment range of low limit set point LSP1.

## 2.6 Alarm

The limit controller has up to three alarm outputs depending on the limit controller model. There are 11 types of alarm functions that can be selected for these alarms. There are 6 kinds of alarm modes available for each alarm function.

### 3.6.1 Alarm Types

There are two different types of alarms as listed below that the user can assign to different alarm outputs.

1. PV. HI: Process value high alarm
2. PV. Lo: Process value low alarm

A process alarm can set two absolute trigger levels. When the process value is higher than  $AxSP$ , a process high alarm (PV. HI) occurs. The alarm is off when the process value is lower than  $AxSP - AxHY$ .

When the process value is lower than  $AxSP$ , a process low alarm (PV. Lo) occurs. The alarm is off when the process is higher than  $AxSP + AxHY$ . A process alarm is independent of the set point.

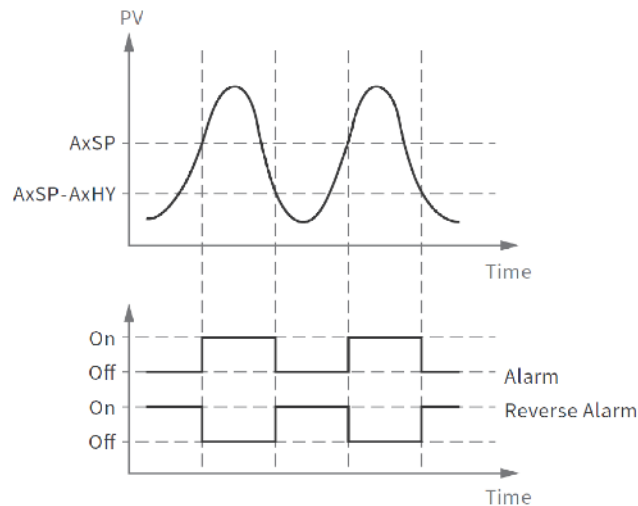

**2-1 Process Value High (PV.HI)**

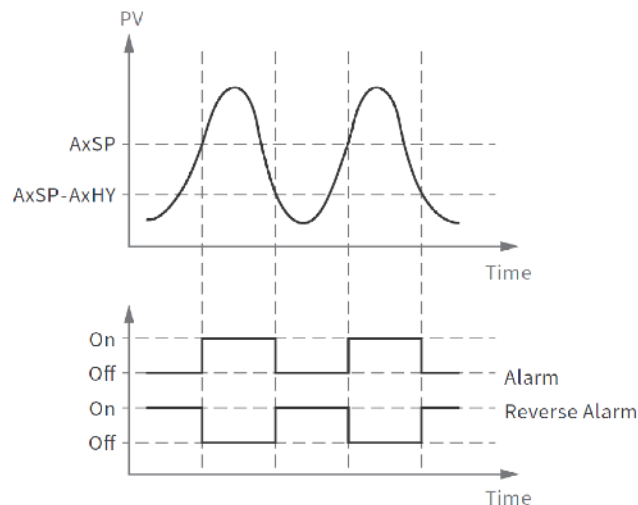

**2-2 Process Value Low (PV.Lo)**

## 2.6.2 Alarm Modes

There are six types of alarm modes available for each alarm function.

1. Normal alarm
2. Latching alarm
3. Normal Alarm Reverse Output
4. Latching Alarm Reverse Output

### 2.6.2.1 Normal Alarm : $ALMD = NoRM$

When a normal alarm is selected, the alarm output is de-energized in the non-alarm condition and energized in an alarm condition.

### 2.6.2.2 Latching Alarm: $ALMD = LtCH$

If a latching alarm is selected, once the alarm output is energized, it will remain unchanged even if the alarm condition is cleared. The latching alarm can be reset by pressing the RESET key once the alarm condition is removed.

### 2.6.2.3 Normal Alarm Reverse Output: $ALMD = NoR.R$

When a normal alarm reverse output is selected, the alarm output is energized in the non-alarm condition and de-energized in an alarm condition.

### 2.6.2.4 Normal Alarm Reverse Output: $ALMD = NoR.R$

If a latching alarm reverse output is selected, once the alarm output is de-energized, it will remain unchanged even if the alarm condition is cleared. The latching alarm can be reset (energized) by pressing the RESET key once the alarm condition is removed.

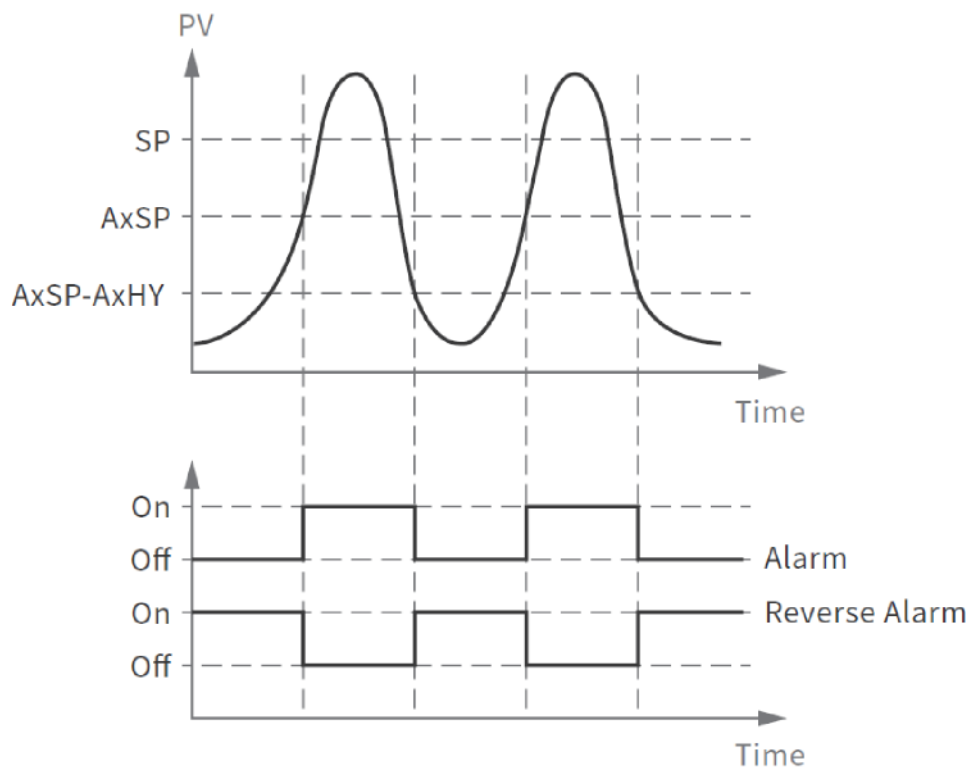

**2-3 Process Value High - Normal Alarm**

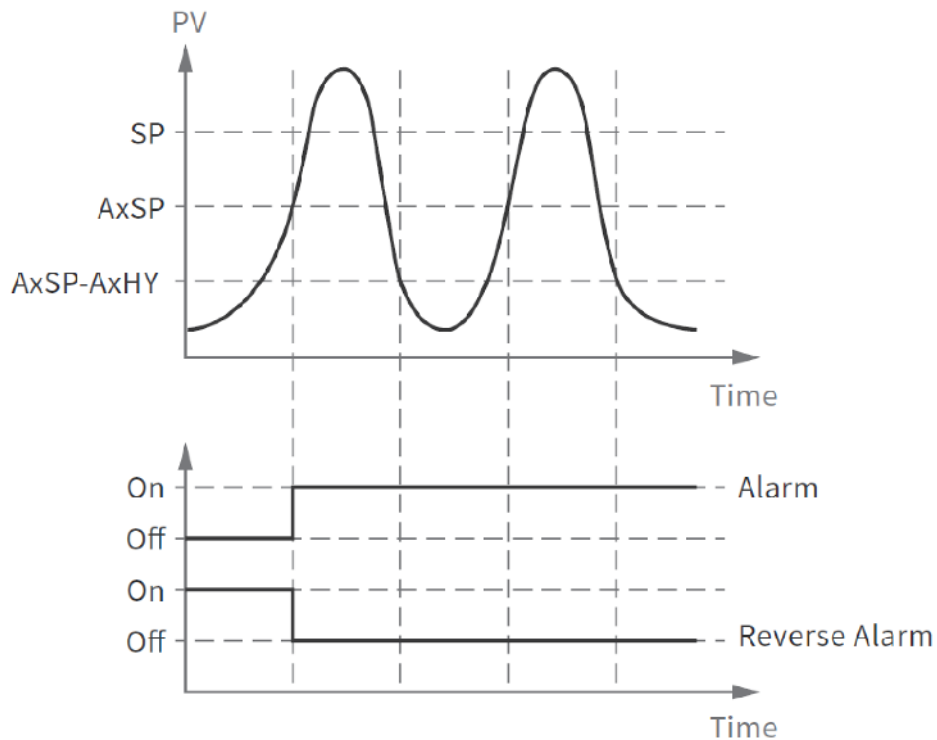

### 2-4 Process Value High - Latching Alarm

#### 2.6.3 Alarm Failure Transfer

Alarm Failure transfer is activated as the unit enters failure mode. The respective Alarm will go on if ON is set for A1FT, A2FT or A3FT and will go off if OFF is set for A1FT, A2FT or A3FT. The unit will enter failure mode if a sensor break occurs or if the A-D converter fails.

## 2.7 User Select Menu Configuration

Conventional limit controllers are designed with parameters in a fixed order. If the user needs a friendlier menu operation to suit their application, most conventional limit controllers do not offer a solution. This series limit controllers have the flexibility for the user to select those parameters which are most significant and put these parameters in an easy access USER menu.

There are eight user-friendly parameters from the below list that can be set for user select menu configuration using the SEL1-SEL5 parameters.

1. **NoNE:** No Parameter
2. **dISP:** DISP
3. **o1HY:** O1HY
4. **A1HY:** A1HY
5. **A1SP:** A1SP
6. **A2HY:** A2HY
7. **A2SP:** A2SP
8. **OFTL:** OFTL
9. **OFTH:** OFTH
10. **CALO:** CALO
11. **CAHI:** CAHI
12. **A3HY:** A3HY (L62/L42 Only)
13. **A3SP:** A3SP (L62/L42 Only)

When using the up-down key to select parameters, all of the above parameters may not be available. The number of visible parameters is dependent on the setup configuration.

## 2.8 User Calibration or PV Shift

Each unit is calibrated in the factory before shipment. The user can still modify the calibration in the field. The basic calibration of the limit controller is highly stable and set for life. User calibration allows the user to offset the permanent factory calibration to:

INPUT:

- Calibrate the limit controller to meet a user reference standard.
- Match the calibration of the limit controller to that of a particular transducer or sensor
- Calibrate the limit controller to suit the characteristics of a particular installation.
- Remove long term drift in the factory set calibration.

There are two parameters: Offset Low (OFTL) and Offset High (OFTH) for adjustment to correct an error in the process value. There are two parameters for the sensor input. These two signal values are CALO and CAHI. The input signal low and high values are to be entered in the CALO and CAHI parameters respectively.

Connect the input with low scale operating temperature (For Example 0.0). Enter the low scale operating temperature in CALO. For example, 0.0. Then monitor the PV. If  $PV \neq CALO$ , adjust the OFTL to make

$PV = CALO$ .

Connect the input with high scale operating temperature (For Example 700.0). Enter the high scale operating temperature in CAHI. For example, 700.0. Then monitor the PV. If  $PV \neq CAHI$  adjust the OFTH to make  $PV = CAHI$ .

As shown below, the two points OFTL and OFTH construct a straight line. For accuracy, it is best to calibrate with the two points as far apart as possible. After the user calibration is complete, the input type will be stored in the memory. If the input type is changed, a calibration error will occur and an error code displayed.

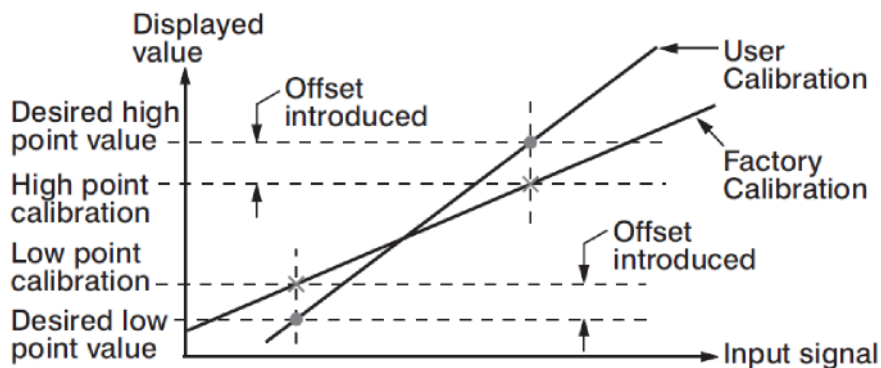

**2-5 Two Point User Calibration**

## 2.9 Digital Filter

In certain applications, the process value is too unstable to be read. To improve this, a programmable low pass filter incorporated in the limit controller can be used. This is a first-order filter with a time constant specified by the FILT parameter. A value of 0.5 seconds is used as a factory default. Adjust FILT to change the time constant from 0 to 60 seconds. 0 seconds represents no filter applied to the input signal. The filter is characterized by the following diagram.

Note

The Filter is available only for the process value (PV) and is performed for the displayed value only. The limit controller is designed to use an unfiltered signal for control even when a filter is applied. If a lagged (filtered) signal is used for control; it may produce an unstable process.

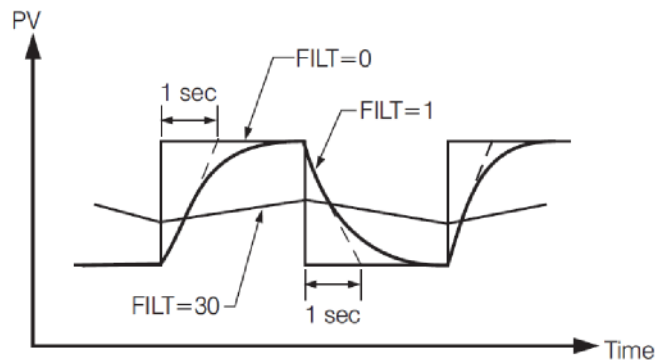

**2-6 Filter Characteristics**

## 2.10 Limit Annunciator

If L\_AN (Limit annunciator) is selected for OUT2, the output 2 will act as a Limit Annunciator. If the limit is or has been reached and the RESET key (or remote reset contacts) has not been pressed since the limit was reached, then the limit annunciator output will be energized and the OUT2 indicator will be lit and remain unchanged until the RESET key or remote reset input is applied.

### \* 2.11 Remote Reset - Not used in this design

If RRST is selected for E1FN or E2FN, the event input terminals will act as remote reset input. Pressing remote reset button will perform the same function as pressing the RESET key. Refer to section 1.4 for RESET key function.

### \* 2.12 Remote Lock - Not used in this design

If LOCK is selected for E1FN or E2FN, the event input terminals will act as remote lock input. Turning the remote lock switch on will keep all the parameter setting from been changed. If the switch is opened the lock indicator is extinguished and the up/down key is enabled. Depends on the user security configuration, the parameters can be changed.

**Note:** The user needs to observe CODE, PASS logic for the remote lock operation. In addition, if remote is needed, it means the remote priority is higher than local. Local changes will be over-written by remote operations. If the code is equal to "0", the remote LOCK feature won't work

## 2.13 Power Up Logic

Configurable power-up logic allows the user to select the latching output relay to require “RESET” or to provide normal or to provide normal latch operation at power-up. If power to the limit controller fails and power is reapplied, the controller goes through power up tests then starts in one of the following configurable conditions configured in PWRU parameter.

0. NoRM (Normal): After power down, the controller will operate normally in the same mode as before power was removed unless a limit has been exceeded after power up.
1. RST (Reset): After power down, the controller latching relay will have to be reset using the “Reset” key or digital(event) input option. The unit must be reset even if the device was not in a limit condition before power down. It must also be reset even if the device is not in a limit condition after power up.

Note: As the user needs to reset the unit by using reset key or digital(event) input, the annunciator output will not be activated at the power on stage at Reset Mode.

2. NoRL (Normal Latch): After power down, the controller will operate normally in the same mode as before power was removed unless a limit has been exceeded upon power up. If the limit was latched at power down, the unit will be in “Limit” at power up and have to be reset.

## 2.14 Reference Data

There are three reference data contained in setup menu. The reference data are read only data. The maximum historical PV, displayed by PV.HI, which shows the maximum process value since the last UNLOCK operation. The minimum historical PV, displayed by PV.LO, which shows the

minimum process value since the last UNLOCK operation. The abnormal time, displayed by T.ABN, which shows the total accumulated time (minutes) during the process has been in abnormal condition since the last UNLOCK operation.

The values of reference data will be initiated as soon as the RESET key is pressed for 4 seconds (UNLOCK operation). After UNLOCK operation, the PV.HI and PV.LO values will start from the current process value and T.ABN value will start from zero.

## 2.15 Failure Transfer

The limit controller will enter failure mode if one of the following conditions occurs.

1. An SBER error occurs due to an input sensor break, an input current below 1mA for 4-20mA, or an input voltage below 0.25V for 1-5 V.
2. An ADER error occurs due to the A-D converter of the limit controller fails.

Output 1 will perform the failure transfer function as the limit controller enters failure mode.

### 2.15.1 Output 1 Failure Transfer

If Output 1 Failure Transfer is activated, it will perform like the limit controller is in abnormal condition.

### 2.15.1 Output 1 Failure Transfer

An alarm failure transfer is activated as the limit controller enters failure mode. After that, the alarm output will transfer to the ON or OFF state which is determined by the set value of A1FT, A2FT and A3FT. Output 1 Failure Transfer

## TEC-960 ERROR CODES:

Error Code	Display Symbol	Description & Reason	Corrective Action
16	EIER	<b>Event Input Error:</b> Two or more event inputs are set to the same function	Do not set the same function in two or more Event Input Function parameters (E1FN through E2FN).
29	EEPR	EEPROM can't be written correctly	Cannot be repaired.
30	CJER	Cold junction compensation for Thermocouple malfunction	Cannot be repaired.
39	SBER	Input sensor break, or input current below 1 mA if 4-20 mA is used, or input voltage below 0.25V if 1 - 5V is used	Replace the input sensor or check all connections.
40	ADER	A to D converter or related component(s) malfunction	Cannot be repaired.

# NOTES

# NOTES

## **RETURNS**

No product returns can be accepted without a completed Return Material Authorization (RMA) form.

## **TECHNICAL SUPPORT**

Technical questions and troubleshooting help is available from Tempco. When calling or writing please give as much background information on the application or process as possible.

E-mail: [techsupport@tempco.com](mailto:techsupport@tempco.com)

Phone: 630-350-2252

800-323-6859

**Note:** Information in this manual was deemed correct at the time of printing. The policy of Tempco is one of continuous development and product improvement, and we reserve the right to modify specifications and designs without prior notice. Not responsible for typographical errors.

# Custom Manufacturer Since 1972

ELECTRIC HEATING ELEMENTS • TEMPERATURE CONTROLS • SENSORS • PROCESS HEATING SYSTEMS

---

## HEAT THINGS UP!

With Thousands of Design Variations  
We Make Everything You Need.

Band Heaters  
Cast-In Heaters  
Radiant Heaters  
Flexible Heaters  
Process Heaters  
Temperature Control

Cartridge Heaters  
Coil & Cable Heaters  
Strip Heaters  
Tubular Heaters  
Instrumentation  
Temperature Sensors

---



607 N. Central Avenue Wood Dale, IL 60191-1452 USA  
P: 630-350-2252 Toll Free: 800-323-6859  
F: 630-350-0232 E: [info@tempco.com](mailto:info@tempco.com)  
[www.tempco.com](http://www.tempco.com)