

## Instructions for Tempco Control Enclosure PCM10080 through PCM10083

Part Number	Input Voltage	Max. Amperage	Required Heater Fusing	Max. Watage 1ph.	Max. Watage 3ph.	Mounting Dimensions	
						A	B
PCM10080	240VAC	24	30 Amps	5760W	9,970W	10.75"	8"
PCM10081	480VAC	24	30 Amps	11,520W	19,930W	14.75"	10"
PCM10082	240VAC	48	60 Amps	11,520W	19,930W	14.75"	10"
PCM10083	480VAC	48	60 Amps	23,000W	39,900W	14.75"	10"

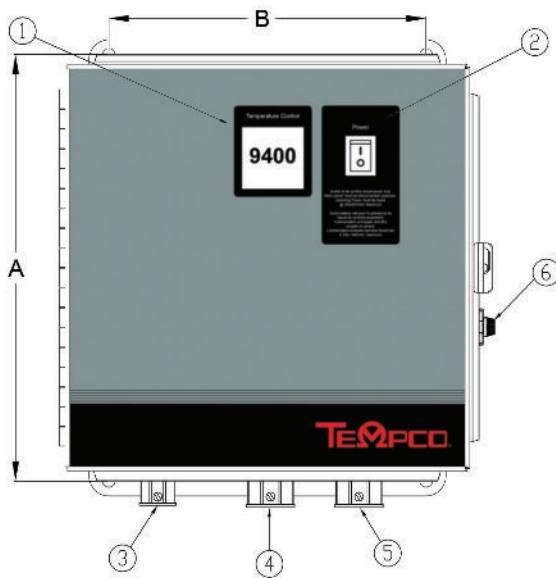

1. TEC-9400 Controller
2. On-Off Rocker Switch - For TEC-9400 Power Only
3. 1/2" EMT Conn. For Sensor
4. **Heater Power PCM10080 Only:** 3/4" EMT Conn  
Heater Power PCM10081-83: 1" EMT Conn
5. **Incoming Power PCM10080 Only:** 3/4" EMT Conn  
Incoming Power PCM10081-83: EMT Conn.
6. 2 Fuse Holders, see spare parts for fuse replacement on next page

**There is no disconnect or heater fusing in this enclosure.  
Heater fusing and disconnect must be supplied by the installer.**

**It is strongly recommended that the process should incorporate a LIMIT CONTROL such as the TEC-910 which will shut down the equipment at a preset process condition in order to preclude possible damage to products or system.**

1. Dangerous voltage capable of causing injury or death is present within this enclosure. Power to all equipment must be disconnected before installation or beginning any troubleshooting procedures. All wiring and component replacement must be made by qualified personnel only.
2. To minimize the possibility of fire or shock, do not expose this console to rain or excessive moisture.
3. Do not use this enclosure in areas where hazardous conditions exist such as excessive shock, vibration, dirt, corrosive gases, oil or where explosive gases or vapors are present.



**WIRING** (for safety, make sure your service power has been disconnected and locked out prior to wiring. All wiring to be performed by qualified personnel only.)

1. Attach the leads from your sensor to the sensor terminal block, terminals 7, 8 & 9. For a thermocouple, most commonly the red lead is negative (-), attach that to terminal 9. The positive (+) lead of the thermocouple should be connected to terminal 8.
2. The TEC-9400 controller is preprogrammed to accept a type J thermocouple. If another sensor is used, the "INPT" setting has to be revised (Note pages 3 & 7).

Please note the wiring diagrams as follows:

PCM10080 - Page 25

PCM10081 - Page 26

PCM10082 - Page 27

PCM10083 - Page 28

Wire your single phase supply to terminals 1 & 2. If you are using three phase power, wire to terminals 1, 2 & 3.

Connect your heater load to terminals 4 & 5 if using single phase, 4, 5 & 6 if using three phase.

Follow all local and national codes.

Add disconnect and fusing as required.

Before applying power, check tightness of all terminals.

## OPERATION

1. Refer to the instruction manual provided for complete operation and auto-tuning instructions for the TEC-9400 temperature controller.
2. Close and secure the door. Switch on the enclosure. Using the up & down pushbuttons on the TEC-9400 controller, start out with the temperature set low to test your system performance.

If the set point temperature is being maintained, set your desired temperature setpoint.

If your setpoint temperature is not being maintained, please refer to the auto-tuning procedure in the attached manual.

If auto-tuning does not produce the required results, manual tuning may be necessary.

**Note: The signal of the output circuit is wired through output 2 of the TEC-9400 which can be used as a cut-out in the event of an over-setpoint temperature condition. This is a deviation contact set to 30° F above the setpoint.**

**In the event of an over-setpoint temperature condition, output 2 will open, cutting the control signal to the output relay.**

**This deviation setpoint can be changed by accessing “A1DV” in the TEC-9400 (note Pages 5 & 9). This is not meant to be a redundant safety controller.**

**Refer to our TEC-910 for a safety controller.**

## SPARE/REPLACEMENT PARTS

### Tempco Part Number

### Description

EHD-124-276	(2) TEC Control fuses rated 1 amp, 250VAC, 1/4” x 1-1/4”, Bussmann ABC-1 or equal (PCM10080/PCM10082)
EHD-124-253	(2) TEC Control fuses rated 3/10 amp, 600VAC class CC. Littelfuse KLDR-3/10 or equal (PCM10081/PCM10083)

## 1-1. TEC-9400 Front Panel Keys and Display

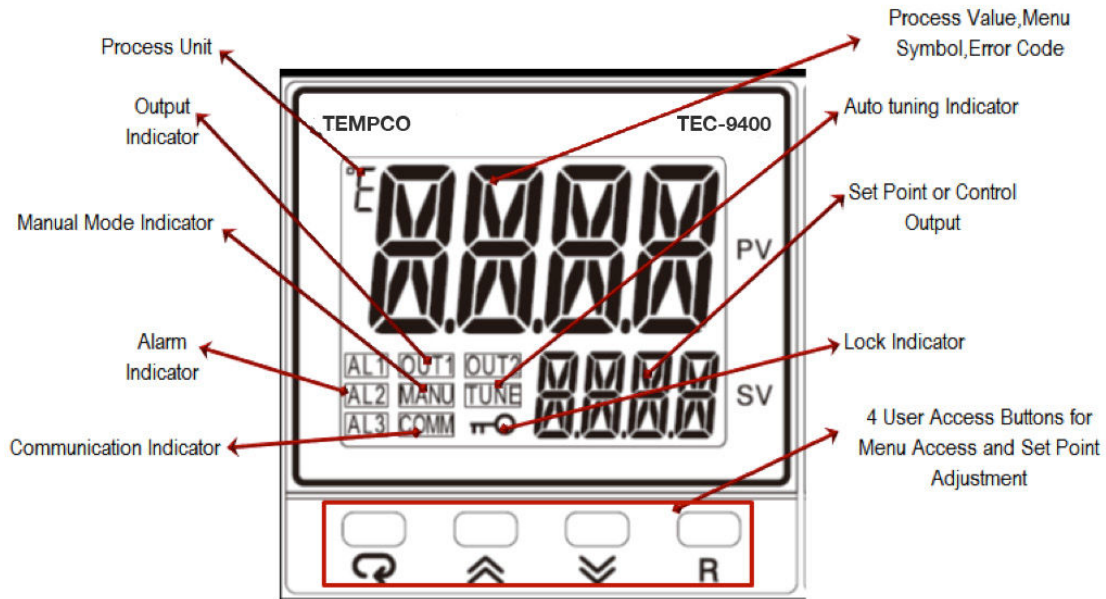

### KEYPAD OPERATION

#### SCROLL KEY:

This key is used to scroll through a menu to select a parameter to be viewed or adjusted.

#### UP KEY:

This key is used to increase the value of the selected parameter.

#### DOWN KEY:







This key is used to decrease the value of the selected parameter.

#### RESET KEY:

This key is used to:

1. Revert the display to the home screen.
2. Reset a latching alarm once the alarm condition is removed.
3. Stop manual control mode, Auto-Tuning mode or calibration mode.
4. Clear an Auto-Tuning or communication error message.
5. Restart the dwell timer when the dwell timer has timed out.
6. Enter the manual control menu if failure mode occurs.

#### ENTER KEY:

1. Enter the setup menu. The display will show .
2. Enter manual control mode. Press and hold  for 6.2 seconds, then let go to enter manual mode. The display will show .
3. Enter Auto-Tuning mode. Press and hold  for 7.4 seconds, then let go to select Auto-Tuning. The display will show .
4. Perform calibration of a selected parameter during the calibration procedure. Press and hold  for 8.6 seconds, then let go to select calibration mode.

During power-up, the upper display will show PROG and the lower display will show the Firmware version for 6 seconds.

# 1.1 Menu Flowchart

The Menu has been divided into 5 groups. They are as follows:

1. User Menu - Below
2. Setup Menu - Page 3
3. Manual Mode Menu - Page 6
4. Auto-Tuning Mode Menu - Page 6
5. Calibration Mode Menu (not recommended, calibration section has been removed)

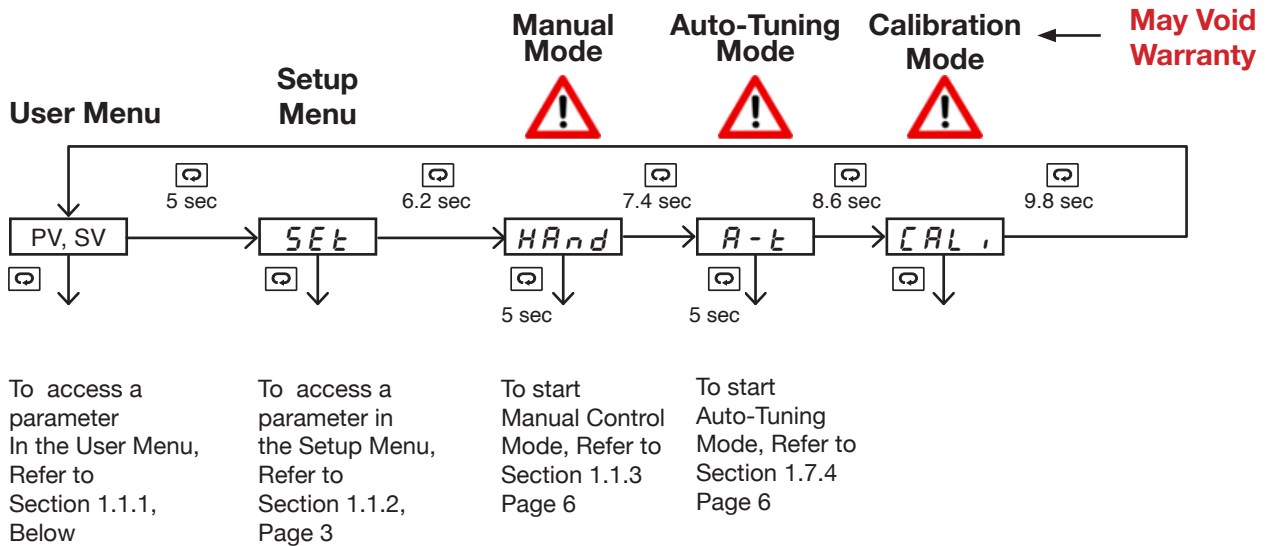

To access a parameter In the User Menu, Refer to Section 1.1.1, Below

To access a parameter in the Setup Menu, Refer to Section 1.1.2, Page 3

To start Manual Control Mode, Refer to Section 1.1.3 Page 6

To start Auto-Tuning Mode, Refer to Section 1.7.4 Page 6

Press [Next] for the next parameter

Press [Next] and [Up] key to return to the previous parameter

## 1.1.1 User Menu

The following user menu parameters are available depending on the current setup configuration of the controller.

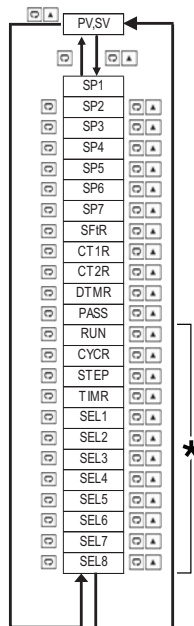

**\* NOT USED IN THIS DESIGN**

**ERROR CODES ARE LISTED ON PAGE 22.**

## 1.1.2 Setup Menu

The setup menu has been categorized in to eight categories. They are listed below.

1. Basic Menu - Below
2. Output Menu (Pgs. 4 & 8)
3. Alarm Menu (Pg. 5)
4. Event Input Menu \*
5. User Select Menu \*
6. Communication Menu \*
7. Current Transformer Menu \*
8. Profile Menu \*

### 1.1.2.1 Basic Menu (bASE)

In the setup menu, when the upper display says “SET”, Use the ▲ or ▼ keys to get “bASE” in the lower display. Then use the ◻ key to cycle through the “bASE” menu parameters. See Page 7.

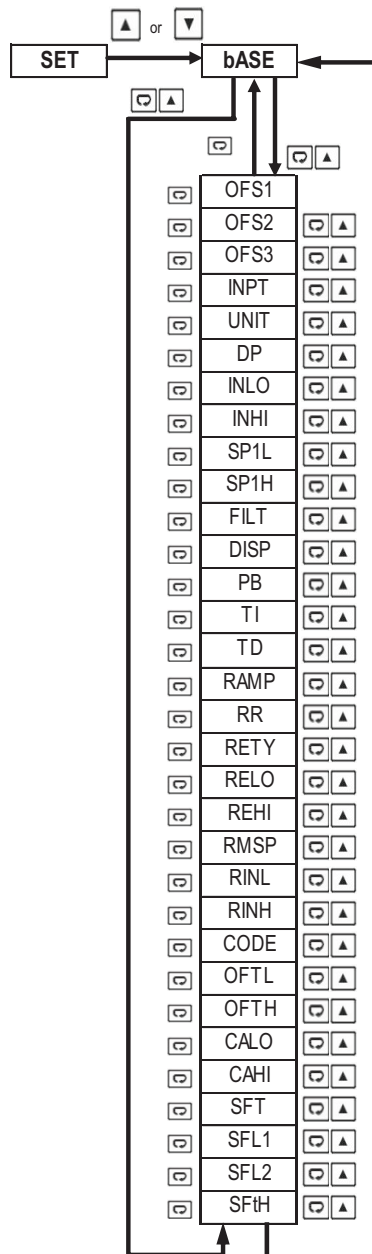

**\* NOT USED IN THIS DESIGN**

### 1.1.2.2 Output Menu (oUT)

In the setup menu, when the upper display says “SET”, use the  $\uparrow$  or  $\downarrow$  key to get “oUT” in the lower display. Then, use the  $\square$  key to cycle through the “oUT” menu parameters. (Note Page 8).

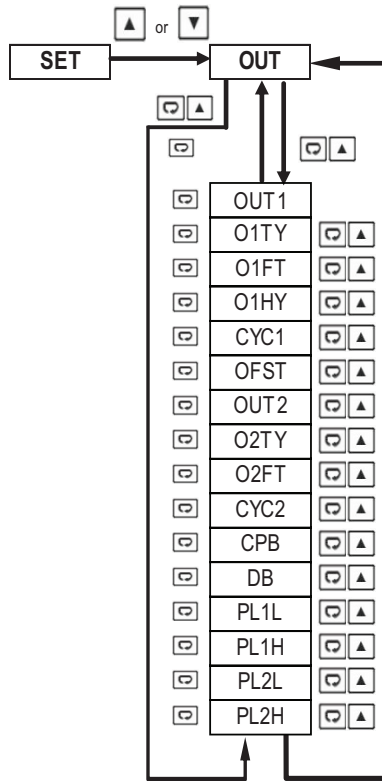

### 1.1.2.3 Event Input Menu (EI) – *Does not apply for this unit*

In the setup menu, when the upper display says “SET”, use the  $\uparrow$  or  $\downarrow$  key to get “EI” in the lower display. Then use the “ $\square$ ” key to cycle through the “EI” (event input) menu parameters.

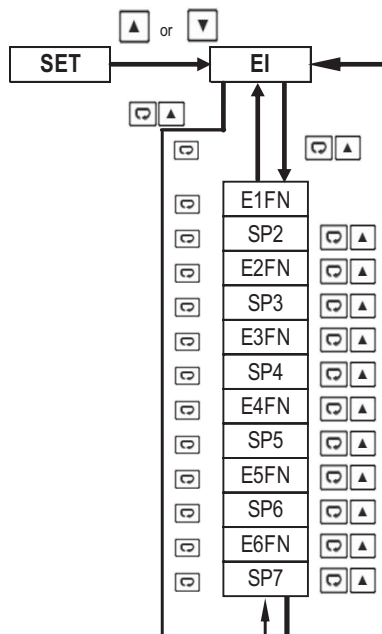

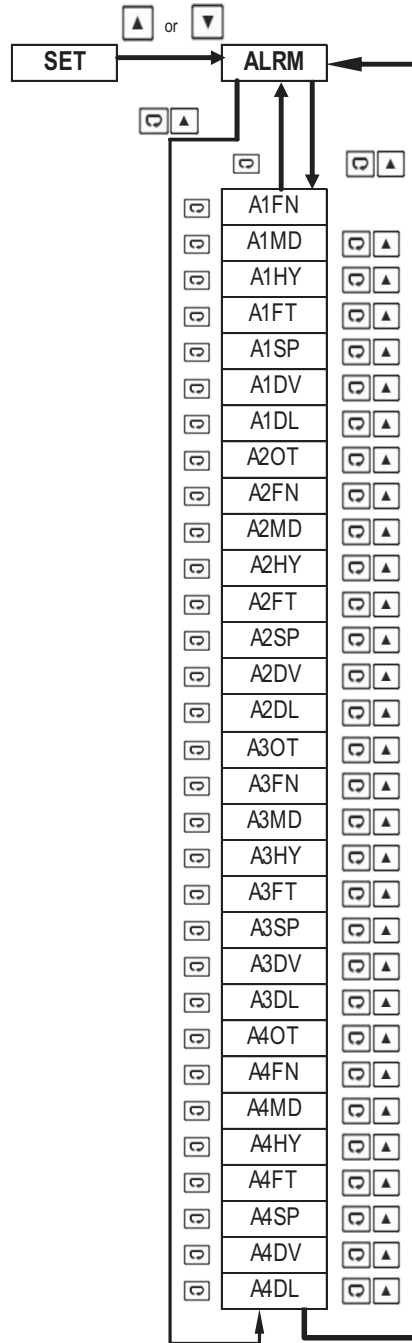

### 1.1.2.4 Alarm Menu (ALRM)

In the setup menu, when the upper display says “SET”, use the  $\uparrow$  or  $\downarrow$  key to get “ALRM” in the lower display. Then use the “ $\square$ ” key to cycle through the “ALRM” menu parameters. (Note Page 9).



### 1.1.3 Manual Mode Menu Used If Sensor Fails (See Pg. 21)

Press and hold the “” key for approx. 6sec until the “HAND” parameter is shown in the upper display. Then, press and hold the “” key for an additional 5 sec. until an “MANU” led starts to flash in the lower left of the display. Then, use the “” key to cycle through the available options. User is able to manually set the out output to be energized from 0-100% of the cycle time.

“Hx.xx” is used to adjust output 1.

“Cx.xx” is used to adjust output 2.

You are able to exit manual mode by pressing and holding the  key.

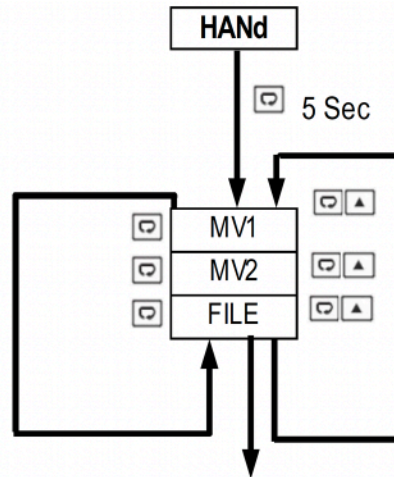



Press  key 5 Sec To execute the selected default program

### 1.1.4 Auto-Tuning Mode - Tunes PID Parameters to Your Application (See Pg. 19)

**A-t**

Press and hold the “” key for approx. 7sec until the “A-T” parameter is shown in the upper display.

Press and hold the “” key for 5 seconds to activate Auto-Tuning Mode. Continue to hold the “” key for an additional 3 seconds, else the display will revert to a “User Menu” parameter.

Auto-tuning allows the controller to find its own optimal control parameters (PID) by measuring the speed of your thermal process.

## 1.2 Parameter Description



Modbus Register Address	Parameter Notation	Parameter Description	Range	Default Value
0	SP1	Set Point 1 (Used for Output 1)	Low: SP1L High: SP1H	77.0°F (25.0°C)
8	INPT	Input Sensor selection (See Pg. 10)	<b>0 J<sub>tC</sub></b> : J type Thermocouple <b>1 K<sub>tC</sub></b> : K type Thermocouple <b>13 Pt.dN</b> : PT100 Ω DIN curve	0
9	UNIT	Input Unit selection	<b>0 oC</b> : °C unit <b>1 oF</b> : °F unit <b>2 Pu</b> : Process unit	1
10	DP	Decimal Point selection	<b>0 No.dP</b> : No decimal point <b>1 1-dP</b> : 1 decimal digit <b>2 2-dP</b> : 2 decimal digits <b>3 3-dP</b> : 3 decimal digits	0
13	SP1L	Low Limit of set point 1	Low: -19999 High: SP1H	0.0°F (-17.8°C)
14	SP1H	High Limit of set point 1	Low: SP1L High: 45536	1000.0°F (537.8°C)
15	FILT	Filter Damping time constant of PV (See Pg. 18)	<b>0 0</b> : 0 second time constant <b>1 0.2</b> : 0.2 second time constant <b>2 0.5</b> : 0.5 second time constant <b>3 1</b> : 1 second time constant <b>4 2</b> : 2 second time constant <b>5 5</b> : 5 second time constant <b>6 10</b> : 10 second time constant <b>7 20</b> : 20 second time constant <b>8 30</b> : 30 second time constant <b>9 60</b> : 60 second time constant	2
16	DISP	Secondary display selection	<b>0 None</b> : No Display <b>1 MV1</b> : Display MV1 <b>2 MV2</b> : Display MV2 <b>3 tMR</b> : Display Dwell Timer <b>4 PRoF</b> : display Profile Status	0
17	PB	Proportional Band value (See Pg. 20)	Low: 0.0 High: 932.0°F (500.0°C)	18.0°F (10.0°C)
18	TI	Integral Time value (See Pg. 20)	Low: 0.0 High: 3600 sec	100
19	TD	Derivative Time value (See Pg. 20)	Low: 0.0 High: 360.0 sec	25

Basic Menu

	Modbus Register Address	Parameter Notation	Parameter Description	Range	Default Value
Output Menu ↑ ↓	20	OUT1	Output 1 function	<b>0 REVR:</b> Reverse (heating) control action <b>1 dIRT:</b> Direct (cooling) control action	0
	21	O1TY FACTORY SET, DO NOT CHANGE	Output 1 signal type	<b>0 RELY:</b> Relay output <b>1 SSrd:</b> Solid state relay drive output <b>2 4-20:</b> 4-20mA linear current <b>3 0-20:</b> 0-20mA linear current <b>4 0-5V:</b> 0-5VDC linear voltage <b>5 1-5V:</b> 1-5VDC linear voltage <b>6 0-10:</b> 0-10VDC linear voltage	0
	22	O1FT	Output 1 failure transfer mode	Select BPLS (Bumpless transfer), or 0.0 ~ 100.0 % to continue output 1 control function if the sensor fails, or select OFF (0) or ON (1) for ON-OFF control	0
	23	O1HY	Output 1 ON-OFF control hysteresis	Low: 0.2°F (0.1°C) High: 90.0°F (50.0°C)	0.2°F (0.1°C)
	24	CYC1	Output 1 cycle time	Low: 0.1 High: 90.0 sec.	18.0
Basic Menu ↑ ↓	26	RAMP	Ramp function selection (See Pg. 15)	<b>0 NoNE:</b> No Ramp Function <b>1 MINR:</b> Use °/minute as Ramp Rate <b>2 HRR:</b> Use °/hour as Ramp Rate	0
	27	RR	Ramp Rate (See Pg. 15)	Low: 0.0 High: 932°F (500°C)	0

	Modbus Register Address	Parameter Notation	Parameter Description	Range	Default Value
Alarm Menu ↑ ↓	34	A1FN	Alarm 1 function for alarm 1 output (See pg. 14)	<b>0 NoNE:</b> No alarm function <b>1 dtMR:</b> Dwell timer action <b>2 dE.HI:</b> Deviation high alarm <b>3 dE.Lo:</b> Deviation low alarm <b>4 db.HI:</b> Deviation band out of band alarm <b>5 db.Lo:</b> Deviation band in band alarm <b>6 PV.HI:</b> Process value high alarm <b>7 PV.Lo:</b> Process value low alarm <b>8 H.bK:</b> Heater break alarm <b>9 H.St:</b> Heater short alarm	3
	35	A1MD	Alarm 1 operation mode	<b>0 NoRM:</b> Normal alarm action <b>1 LtCH:</b> Latching alarm action <b>2 HoLd:</b> Hold alarm action <b>3 Lt.Ho:</b> Latching & Hold action <b>4 SP.Ho:</b> Set point holding alarm	0
	36	A1HY	Hysteresis control of Alarm 1	Low: 0.2°F (0.1°C) High: 90.0°F (50.0°C)	0.2°F (0.1°C)
	37	A1FT	Alarm 1 failure transfer mode	<b>0 OFF:</b> Alarm output OFF if sensor fails <b>1 ON:</b> Alarm output ON if sensor fails	1
	38	A1SP	Alarm 1 set point	Low: -19999 High: 45536	30.0°F (10°C)
	39	A1DV	Alarm 1 deviation value	Low: -19999 High: 45536	30.0°F (10.0°C)
Output Menu ↑ ↓	61	PL1L	Output 1 Low Power limit	Low: 0 High: PL1H or 50%	0
	62	PL1H	Output 1 High Power limit	Low: PL1L High: 100 %	100
User Menu ↑ ↓	94	PASS	Password entry (See Next Page)	Low: 0 High: 9999	0

## 2. PROGRAMMING

Press and hold  for 5 seconds, then release to enter the setup menu. Press and release  to cycle through the list of parameters. The upper display indicates the parameter symbol, and the lower display indicates the value of the selected parameter.

### 2.1 User Security

There are two parameters, PASS (password) and CODE (security code), which will control the lockout program.

CODE Value	PASS Value	Access Rights
0	Any Value	All parameters are changeable
500	=500	All parameters are changeable
	≠500	All parameters are changeable except calibration parameters
1000	=1000	All parameters are changeable
	≠1000	Only user menu parameters changeable
9999	=9999	All parameters are changeable
	≠9999	Only SP1 to SP7 are changeable
Others	=CODE	All parameters are changeable
	≠CODE	No parameters can be changed

### 2.2 Signal Input

**INPT:** Select the desired sensor type or signal type for the signal input.

**Range:** (Thermocouple) J\_TC, K\_TC

**UNIT:** Select the desired process unit

**Options:** °C, °F, PU (Process unit). If the unit is neither °C nor °F, then is set to PU.

**DP:** Select the desired resolution (decimal points) for the process value.

**Range:** For Thermocouple and RTD Signal NO.DP, 1-DP.

## 2.3 Control Output

There are 4 kinds of control modes that can be configured as shown in the following figure.

Control Mode	OUT 1	OUT 2	O1HY	O2HY	CPB	DB
Heat Only	REVR	X	Δ	X	X	X
Cool Only	DIRT	X	Δ	X	X	X
Heat PID Cool ON-OFF	REVR	DE.HI	X	O	X	X
Heat PID Cool PID	REVR	COOL	X	X	O	O

X: Not applicable

O: Adjust to meet process Requirements

Δ: Required if ON-OFF Control is configured

### 2.3.1 Heat Only ON-OFF Control

Select REVR for OUT1, Set PB to 0. O1HY is used to adjust the hysteresis for ON-OFF control. The output 1 hysteresis (O1HY) setting is only available when PB = 0. The heat only ON-OFF control function is shown below.

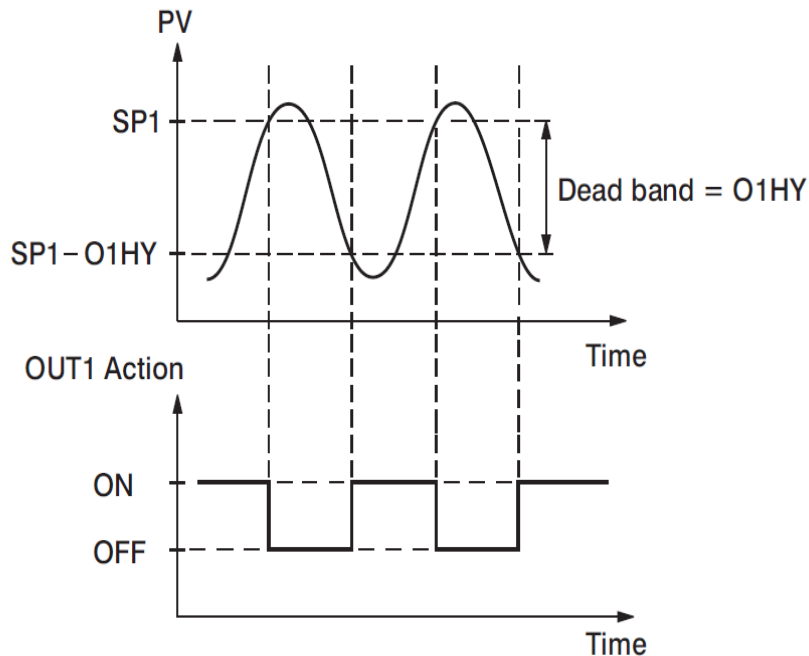

#### **2-1. Heat Only ON-OFF Control**

ON-OFF control may cause excessive process oscillations even if the hysteresis is set to the smallest value. If ON-OFF control is used (i.e. PB = 0), TI, TD, CYC1, OFST, CYC2, CPB, DB will no longer be applicable and will be hidden. Auto-Tuning mode and Bumpless transfer will also be unavailable.

### 2.3.2 Heat only P or PD Control

Select REVR for OUT1, set TI = 0, OFST is used to adjust the control offset (manual reset). If PB  $\neq$  0 then O1HY will be hidden.

**OFST Function:** OFST is measured in % with a range of 0 - 100.0 %. When the process is stable, let's say the process value is lower than the set point by 5°F. Let's also say that 20.0 is used for the PB setting. In this example, 5°F is 25% of the proportional band (PB).

By increasing the OFST value by 25%, the control output will adjust itself, and the process value will eventually coincide with the set point.

When using Proportional (P) control (TI = 0), Auto-Tuning will be unavailable. Refer to the "manual tuning" section for the adjustment of PB and TD. Manual reset (OFST) is usually not practical because the load may change from time to time; meaning the OFST setting would need to be constantly adjusted. PID control can avoid this problem.

### 2.3.3 Heat only PID Control

Select REVR for OUT1. PB and TI should not be zero. Perform Auto-Tuning for initial startup. If the control result is not satisfactory, use manual tuning or try Auto-Tuning a second time to improve the control performance.

### 2.3.4 Cool only Control

ON-OFF control, Proportional control, and PID control can be used for cooling control. Set "OUT1" to DIRT (direct action).

**NOTE:** ON-OFF control may result in excessive overshoot and undershoot in the process. Proportional control could result in a deviation of the process value from the set point. It is recommended to use PID control for Heating or Cooling control to produce a stable process value.

### 2.3.5 Output 2 ON-OFF Control (Alarm function)

Output 2 can also be configured as an alarm output. There are 8 kinds of alarm functions and a Dwell timer (dtMR) that can be selected for output 2. They are dtMR (Dwell Timer), dE.HI (deviation high alarm), dE.Lo (deviation low alarm), dB.Hi (Out of band alarm), dB.Lo (In band Alarm), PV.HI (process value high alarm) and PV.LO (process value low alarm), H.bK (Heater Break Alarm), H.St (Heater Short Alarm).

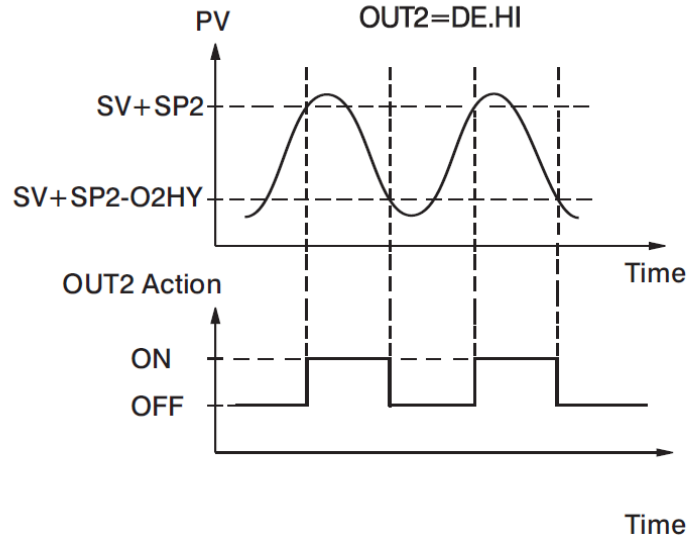

#### 2-2. Output 2 Deviation High Alarm

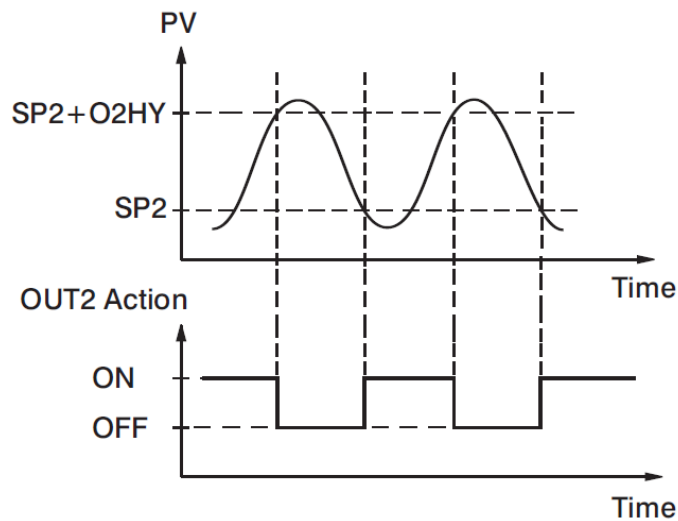

#### 2-3. Output 2 Process Low Alarm

## 2.4 Alarm

The controller has up to four alarm outputs depending on the controller model. There are 11 types of alarm functions and one dwell timer that can be selected. There are 4 kinds of alarm modes (A1MD, A2MD, A3MD, and A4MD) available for each alarm function (A1FN, A2FN, A3FN, and A4FN). In addition to the alarm output, output 2 can also be configured as an alarm. But output 2 provides 8 different alarm functions or dwell timer available.

The Alarm outputs can be controlled by Event input1 and Event input 2 by selecting **Event Input 1 Control Alarm Output (E1.C.o.)** and **Event Input 2 Control Alarm Output (E2.C.o.)** for alarm function A2FN and A3FN. The output will be ON as long as the event input is ON. The output will go OFF when the input is OFF.

### 3.5.2 Alarm Modes

There are five types of alarm modes available for each alarm function.

1. Normal alarm
2. Latching alarm
3. Holding alarm
4. Latching / Holding alarm
5. Set point Holding Alarm

#### 3.5.2.1 Normal Alarm: ALMD = NORM

When a normal alarm is selected, the alarm output is de-energized in the non-alarm condition and energized in an alarm condition.

#### 3.5.2.2 Latching Alarm: ALMD = LTCH

If a latching alarm is selected, once the alarm output is energized, it will remain unchanged even if the alarm condition is cleared. The latching alarm can be reset by pressing the “R” key once the alarm condition is no longer present.

#### 3.5.2.3 Holding Alarm: ALMD = HOLD

A holding alarm prevents an alarm condition during power up. This will ignore the alarm condition the first time after initial powering on of the controller. Afterwards, the alarm performs the same function as a normal alarm.

#### 3.5.2.4 Latching / Holding Alarm: ALMD = LT.HO

A latching / holding alarm performs both holding and latching functions. The latching alarm can be reset by pressing the “R” key once the alarm condition is no longer present.

#### 3.5.2.5 Set Point Holding Alarm: ALMD = SP.HO

A set point holding alarm prevents an alarm during power up or when changing the set point. The alarm output is de-energized whenever the set point is changed even if it is in an alarm condition. The alarm reverts to a normal alarm once the alarm condition is removed.

### 3.5.3 Alarm Delay

In certain applications during startup, nuisance alarms can occur before the process value reaches the set point. To avoid these kinds of nuisance alarms, a time delay for alarms is available. To enable the time delay for alarms, set the delay time using the A1DL, A2DL, A3DL, and A4DL parameters. These parameters will help to avoid nuisance alarms until the process value reaches set point.

## 2.5 Ramp

The ramping function is performed during power up or any time the set point is changed. Choose “MINR” (ramp in minutes) or “HRR” (ramp in hours) for the “RAMP” setting, and the controller will perform the ramping function. The ramp rate is programmed by adjusting the “RR” setting. The ramping function is disabled whenever the controller enters Failure mode, Manual control mode, Auto-Tuning mode or Calibration mode.

### 2.5.1 Ramping Example without Dwell Timer

Set the “RAMP” setting to “MINR” to ramp in minutes.

Set the ramp rate (RR) to 10.

The starting temperature is 30°C.

The setpoint is initially set to 200°C.

After the process warms up, the user changed the setpoint to 100°C after 30 minutes.

After power up, the process will behave as shown below.

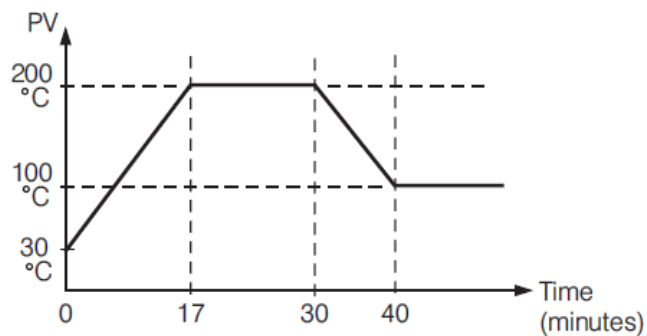

## 2-4. Ramp Function

**Note:** When the ramp function is used, the lower display will show the current ramping value. However, it will revert to show the set point value as soon as the up or down key is touched for adjustment. The ramp rate is initiated at power on and/or whenever the Set point is changed. Setting the “RR” setting to zero means no ramping function is used.

The Dwell timer can be with or without a Ramp. Alarm outputs can be configured as dwell timers by selecting dtMR for A1FN. If A1FN is set to dtMR, Alarm 1 will act as a dwell timer. Similarly, Alarm 2, Alarm3 and Alarm4 will act as dwell timers if A2FN, A3FN, or A4FN is set to “dtMR”. When the dwell timer is configured, the parameter “DTMR” is used for dwell time adjustment.

A deviation alarm energizes when the process value deviates too far from the set point.

- When the process value is higher than  $SV+A1DV$ , a **deviation high alarm (dE.HI)** occurs. The alarm is off when the process value is lower than  $SV+A1DV-A1HY$ .
- When the process value is lower than  $SV+A1DV$ , a **deviation low alarm (dE.Lo)** occurs. The alarm is off when the process value is higher than  $SV+A1DV+A1HY$ .

The trigger level of a deviation alarm moves with the set point.

A deviation band alarm presets two trigger levels centered on the set point.

The two trigger levels are  $SV+A1DV$  and  $SV-A1DV$ . When the process value is higher than  $(SV+A1DV)$  or lower than  $(SV - A1DV)$ , a **deviation band high alarm (dB.HI)** occurs. When the process value is within the trigger levels, a **deviation band low alarm (dB.Lo)** occurs.

**In the above descriptions, SV denotes the current set point value for control.**

A process alarm can set two absolute trigger levels. When the process value is higher than  $A1SP$ , a **process high alarm (PV.HI)** occurs. The alarm is off when the process value is lower than  $A1SP-A1HY$ . When the process value is lower than  $A1SP$ , a **process low alarm (PV.Lo)** occurs. The alarm is off when the process is higher than  $A1SP+A1HY$ . A process alarm is independent of the set point.

In the above description,  $A1SP$  and  $A1HY$  denote the Alarm1 Set point and Alarm1 Hysteresis. The respective Set point and Hysteresis parameters need to be set for other Alarm outputs.

For example, the process set point set to 100. As the process approaches 100, it may oscillate between 103 and 97. During this time the Hi Alarm will be activated and deactivated continuously. To avoid these kind of nuisance alarms, the alarm delay function can be used. It will generate the alarm after the PV is in an alarm condition continuously a preconfigured period of time in the alarm delay parameters. The alarm delay can be configured in minutes and seconds.

### 2.5.2 Alarm Failure Transfer

An alarm failure transfer is activated as the controller enters failure mode. After that, the alarm output will transfer to the ON or OFF state which is determined by the set value of  $A1FT$ ,  $A2FT$ ,  $A3FT$ , and  $A4FT$ .

## 2.6 User Calibration - Display Offset







Each unit is calibrated in the factory before shipment. The user can still modify the calibration in the field.

The basic calibration of the controller is highly stable and set for life. User calibration allows the user to offset the permanent factory calibration in order to:

- Calibrate the controller to meet a user reference standard.
- Match the calibration of the controller to that of a particular transducer or sensor input.
- Calibrate the controller to suit the characteristics of a particular installation.
- Remove long term drift in the factory set calibration.

There are two parameters: Offset Low (OFTL) and Offset High (OFTH) for adjustment to correct an error in the process value.

There are two parameters for the sensor input. These two signal values are CALO and CAHI. The input signal low and high values are to be entered in the CALO and CAHI parameters respectively.

Refer to page 1 for key operation and page 10 for the operation flowchart. Press and hold the  key until the setup Menu page is obtained. Then, press and release the  key to navigate to the calibration low parameter OFTL. Send your low signal to the sensor input of the controller, then press and release the  key. If the process value (the upper display) is different from the input signal, the user can use  and  keys to change the OFTL value (the lower display) until the process value is equal to the value the user needs. Press and hold the  key for 5 seconds to complete the low point calibration (the display should blink once). The same procedure is applied for high scale calibration.

As shown below, the two points OFTL and OFTH construct a straight line. For the purpose of accuracy, it is best to calibrate with the two points as far apart as possible. After the user calibration is complete, the input type will be stored in the memory. If the input type is changed, a calibration error will occur and an error code `ERR` is displayed.

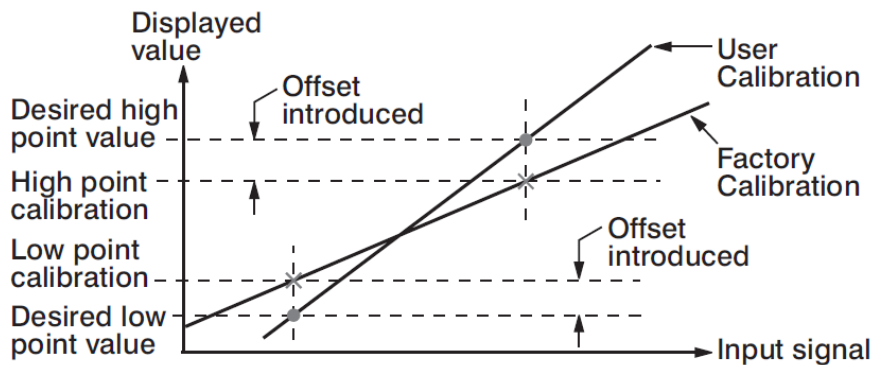

**2-5. Two Point User Calibration**

## 2.6.1 Digital Filter

In certain applications the process value is too unstable to be read. To improve this, a programmable low pass filter incorporated in the controller can be used. This is a first order filter with a time constant specified by the FILT parameter. A value of 0.5 seconds is used as a factory default. Adjust FILT to change the time constant from 0 to 60 seconds. 0 seconds represents no filter applied to the input signal. The filter is characterized by the following diagram.

**Note:** The Filter is available only for the process value (PV), and is performed for the displayed value only. The controller is designed to use an unfiltered signal for control even when a filter is applied. If a lagged (filtered) signal is used for control; it may produce an unstable process.

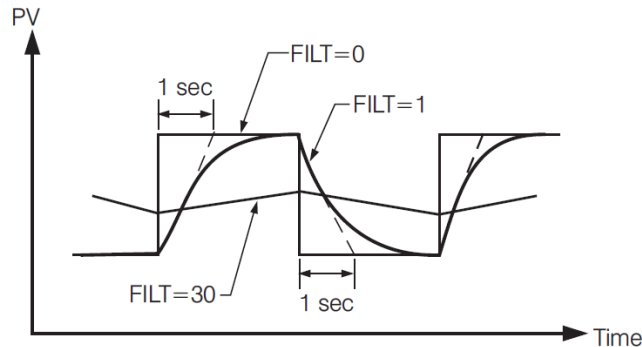

### 2-6. Filter Characteristics

## 2.7 Failure Transfer

The controller will enter failure mode if one of the following conditions occurs:

1. An SBER error occurs due to an input sensor break, an input current below 1mA for 4-20mA, or an input voltage below 0.25V for 1-5 V.
2. An ADER error occurs due to the A-D converter failing. Output 1 and Output 2 will perform the failure transfer (O1.ft & O2.ft) function as the controller enters failure mode.

### 2.6.1 Output 1 Failure Transfer

If Output 1 Failure Transfer is activated, it will perform as follows:

1. If output 1 is configured as proportional control (PB≠0), and BPLS is selected for O1FT, then output 1 will perform a Bumpless transfer. After that, the previous average value of the output will be used for controlling output 1.
2. If output 1 is configured as proportional control (PB≠0), and a value of 0 to 100.0 % is set for O1FT, then output 1 will perform failure transfer. After that the value of O1FT will be used for controlling output 1.
3. If output 1 is configured as ON-OFF control (PB=0), then output 1 will transfer to an off state if OFF is set for O1FT, or it will transfer to an on state if ON is set for O1FT.





## 2.8 Auto-Tuning

 The Auto-Tuning process will be performed at the set point (SP1). The process will oscillate around the set point during the tuning process. Set a set point to a lower value if overshooting beyond the normal process value will cause damage. It is usually best to perform Auto-Tuning at the Set point the machine is expected to be operated at, with the process running normally (i.e. material in the oven, etc.).

Auto-Tuning is generally applied in the following cases:

- Initial setup for a new process.
- The set point is changed substantially from the previous Set point when Auto-Tuning was performed.
- The control result is unsatisfactory.

### 2.8.1 Auto-Tuning Operation Steps

1. The system is set up to run under real-world conditions.
2. “PB and “TI” settings should not be set to zero.
3. The LOCK parameter should be set to NONE.
4. Set the set point to a normal operating value, or a lower value if overshooting beyond the normal process value will cause damage.
5. Press and hold the  key until  appears on the upper display. Continue to hold the “” key for an additional 3 seconds, else the display will revert to a “User Menu” parameter.
6. Press and hold the  key until the TUNE indicator begins to flash.
7. The Auto-Tuning process has begun.

**NOTE:** During Auto-Tuning, the output will stay on until the Process Value reaches the setpoint. This is likely to cause the temperature to exceed the setpoint.

Then, the output will remain off until the process value falls below the setpoint.

This will occur at least two times while the controller “learns” how to control your process.

#### Procedures:



Auto-Tuning can be applied either as the process is warming up (Cold Start) or as the process has been in steady state (Warm Start). After the Auto-Tuning process is completed, the TUNE indicator will stop flashing and the unit will revert to PID control by using its new PID values. The PID values obtained are stored in nonvolatile memory.

### 2.8.2 Auto-Tuning Error

If Auto-Tuning fails, an ATER  message will appear on the upper display in any of the following cases.

- If PB exceeds 9000 ( 9000 PU, 900.0°F or 500.0°C )
- If TI exceeds 1000 seconds
- If the set point is changed during the Auto-Tuning process

### 2.8.3 Solution for an Auto-Tuning Error

1. Try Auto-Tuning once again.
2. Avoid changing the set point value during the Auto-Tuning process.
3. Ensure PB and TI are not set to zero.
4. Use manual tuning.
5. Touch RESET  key to reset the  message.

## 2.9 Manual Tuning

In certain applications, using Auto-Tuning may be inadequate for the control requirement, or, the process moves too slowly to Auto-tune accurately.

If this is the case, the user can try manual tuning.

The following guidelines can be applied for further adjustment of PID values.



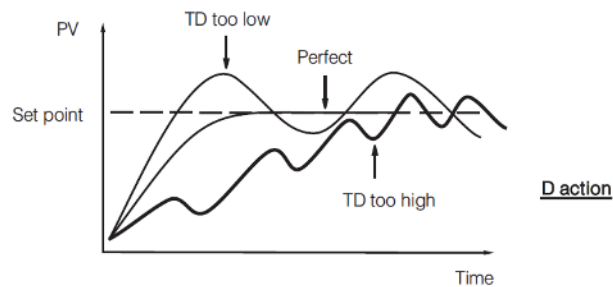
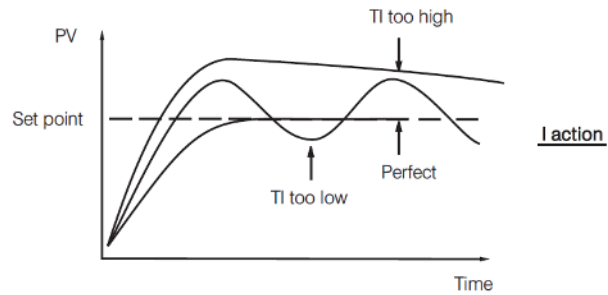
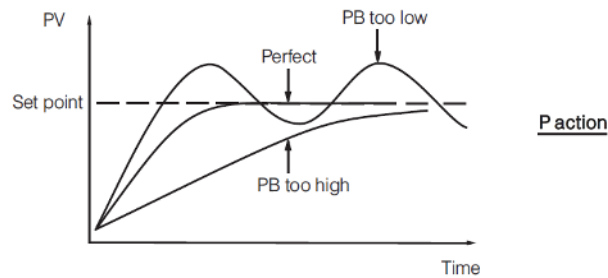

ADJUSTMENT SEQUENCE	SYMPTOM	SOLUTION
Proportional Band ( PB )	Slow Response	Decrease PB
	High overshoot or Oscillations	Increase PB
Integral Time ( TI )	Slow Response	Decrease TI
	Instability or Oscillations	Increase TI
Derivative Time ( TD )	Slow Response or Oscillations	Decrease TD
	High Overshoot	Increase TD





### 2-7. Effects of PID Adjustment

## 2.10 Manual Control

To enable manual control, ensure the LOCK parameter is set to NONE.

Press and hold  until  (Hand Control) appears on the display. Press and hold  until the “MANU” indicator begins to flash. The lower display will show .

 Indicates the output control variable for output 1, and  indicates the control variable for output 2. The user can use the up-down keys to adjust the percentage values for the heating or cooling output. This % value is based on the CYC1 and CYC2 settings, where the associated output will stay on for the % of time the CYC1 & CYC2 values are set for.

Example: If CYC1 is set to 20 seconds, and the controller is set to “H50.0”, the output will be on for 10 seconds, then turn off for 10 seconds.





The controller performs open loop control and ignores the input sensor as long as it stays in manual control mode.

### 2.10.1 Exit Manual Control

Pressing the  key will revert the controller to its normal display mode.

## 3 SETTING CONTROLLER TO FACTORY DEFAULT

The controller’s parameters can be loaded with default values listed in the parameter description table. In certain situations it is desirable to retain these values after the parameters values has been changed. The below procedure to be followed to reload the default values.

1. Ensure the LOCK parameter is set to NONE.
2. Press and hold  until  (Hand Control) appears on the display.
3. Press and release the  key to cycle through the manual mode menu to reach “FILE”.
4. Press and hold  for 5 seconds or until the upper display FILE flash for a moment.

The default values of all parameters are now loaded.

## 4 ERROR CODES FOR TEC-9400 CONTROLLER

Error Code	Display Symbol	Description & Reason	Corrective Action
4	ER04	<b>Illegal setup values used:</b> COOL is used for OUT2 when DIRT (cooling action) is used for OUT1, or when PID mode is not used for OUT1 (PB=0 and/or TI=0)	Check and correct setup values of OUT2, PB1, PB2, TI1, TI2 and OUT1. IF OUT2 is needed for cooling control, the controller should use PID mode (PB≠0 and TI≠0) and OUT1 should use reverse mode (heating action), otherwise, OUT2 cannot be used for cooling control.
10	ER10	<b>Communication error:</b> bad function code	Correct the communication software to meet the protocol requirements.
11	ER11	<b>Communication error:</b> register address out of range	Do not issue an over-range address of the register to the secondary.
14	ER14	<b>Communication error:</b> attempt to write a read-only data	Do not write read-only data or protected data to the secondary.
15	ER15	<b>Communication error:</b> write a value which is out of range to a register	Do not write an over-range data to the secondary register.
16	EIER	<b>Event Input Error:</b> Two or more event inputs are set to the same function	Do not set the same function in two or more Event Input Function parameters (E1FN through E6FN).
26	ATER	<b>Auto-Tuning Error:</b> Failed to perform Auto-Tuning function	<ol style="list-style-type: none"> <li>1. The PID values obtained after Auto-Tuning process are out of range. Retry Auto-Tuning.</li> <li>2. Do not change the set point value during Auto-Tuning process.</li> <li>3. Use manual tuning instead of Auto-Tuning process.</li> <li>4. Do not set a zero value for TI.</li> <li>5. Do not set a zero value for PB.</li> <li>6. Touch RESET key.</li> </ol>
29	EEPR	EEPROM can't be written correctly	Return to factory for repair.
30	CJER	Cold junction compensation for Thermocouple malfunction	Cannot be repaired.
39	SBER	Input sensor break, or input current below 1 mA if 4-20 mA is used, or input voltage below 0.25V if 1 - 5V is used	Cannot be repaired.
40	ADER	A to D converter or related component(s) malfunction	Cannot be repaired.

# NOTES

---

# NOTES

---

PROPRIETARY AND CONFIDENTIAL: THIS DRAWING AND THE INFORMATION WITHIN ARE PROPRIETARY TO TEMPPO ELECTRIC HEATER CORPORATION AND ARE ISSUED IN STRICT CONFIDENCE ON THE CONDITION THAT THIS DRAWING AND ANY INFORMATION CONTAINED THEREIN SHALL NOT BE COPIED, USED FOR MANUFACTURE OR SALE, OR TRANSMITTED OR DISCLOSED TO A THIRD PARTY, IN WHOLE OR IN PART, WITHOUT THE PRIOR WRITTEN CONSENT OF TEMPPO ELECTRIC HEATER CORPORATION. REMOVING THIS DOCUMENT FROM TEMPPO WITHOUT TEMPPO'S WRITTEN CONSENT IS PROHIBITED. TEMPPO ELECTRIC HEATER CORPORATION. ALL RIGHTS RESERVED.		ECO #	NO.	REVISION	DATE	BY
	1	1	UPDATED	1/10/25	BPM	

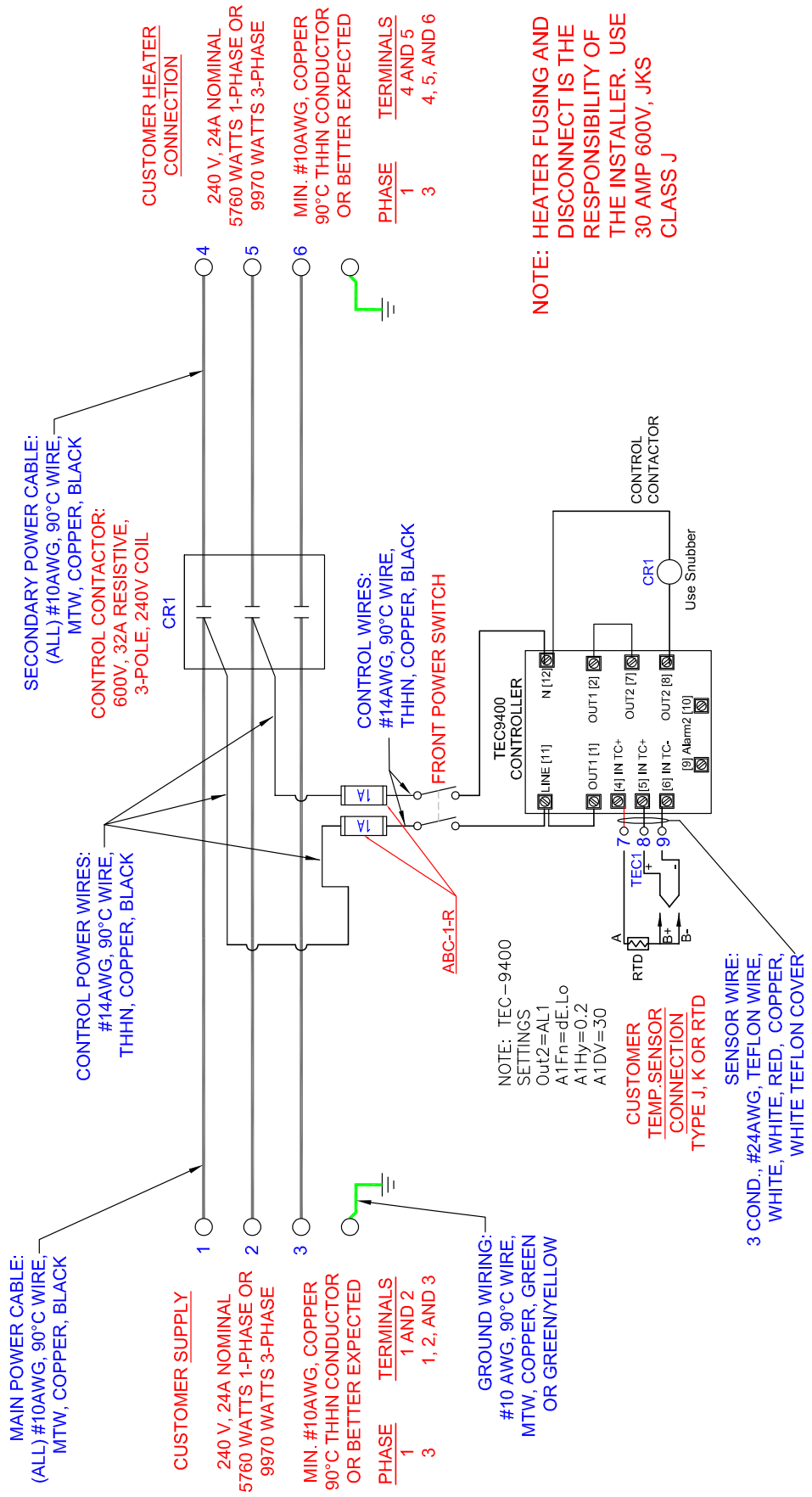

<b>TEMPPO</b> TEMPPO Electric Heater Corporation 607 N. Central Ave. Wood Dale, IL 60191-1452 U.S.A. Email: info@tempco.com		<b>TEMPPO</b> WWW.TEMPPO.COM	
<b>TITLE:</b> INTERNAL WIRING DIAGRAM FOR PCM10080 24A, 240VAC			
<b>SCALE:</b> N/A	<b>DATE:</b> 9/20/19	<b>DRAWN BY:</b> JP	<b>APPROVED:</b> JP
<b>THIRD ANGLE PROJECTION</b>		<b>REV. SHEET</b> 1 OF 1	<b>DRAWING NUMBER:</b> PCM10080-WD

PROPRIETARY AND CONFIDENTIAL: THIS DRAWING AND THE INFORMATION WITHIN ARE PROPRIETARY TO TEMPCO ELECTRIC HEATER CORPORATION AND ARE ISSUED IN STRICT CONFIDENCE ON THE CONDITION THAT THIS DRAWING AND ANY INFORMATION CONTAINED THEREIN SHALL NOT BE COPIED, USE FOR MANUFACTURE OR SALE, OR TRANSMITTED OR DISCLOSED TO A THIRD PARTY, IN WHOLE OR IN PART, WITHOUT THE PRIOR WRITTEN CONSENT OF TEMPCO ELECTRIC HEATER CORPORATION. REMOVING THIS DOCUMENT FROM TEMPCO WITHOUT TEMPCO'S WRITTEN CONSENT IS PROHIBITED. TEMPCO ELECTRIC HEATER CORPORATION, ALL RIGHTS RESERVED.

ECO #	NO.	REVISION	DATE	BY
	1	UPDATED CONTROL SETTINGS	1/10/25	BPM

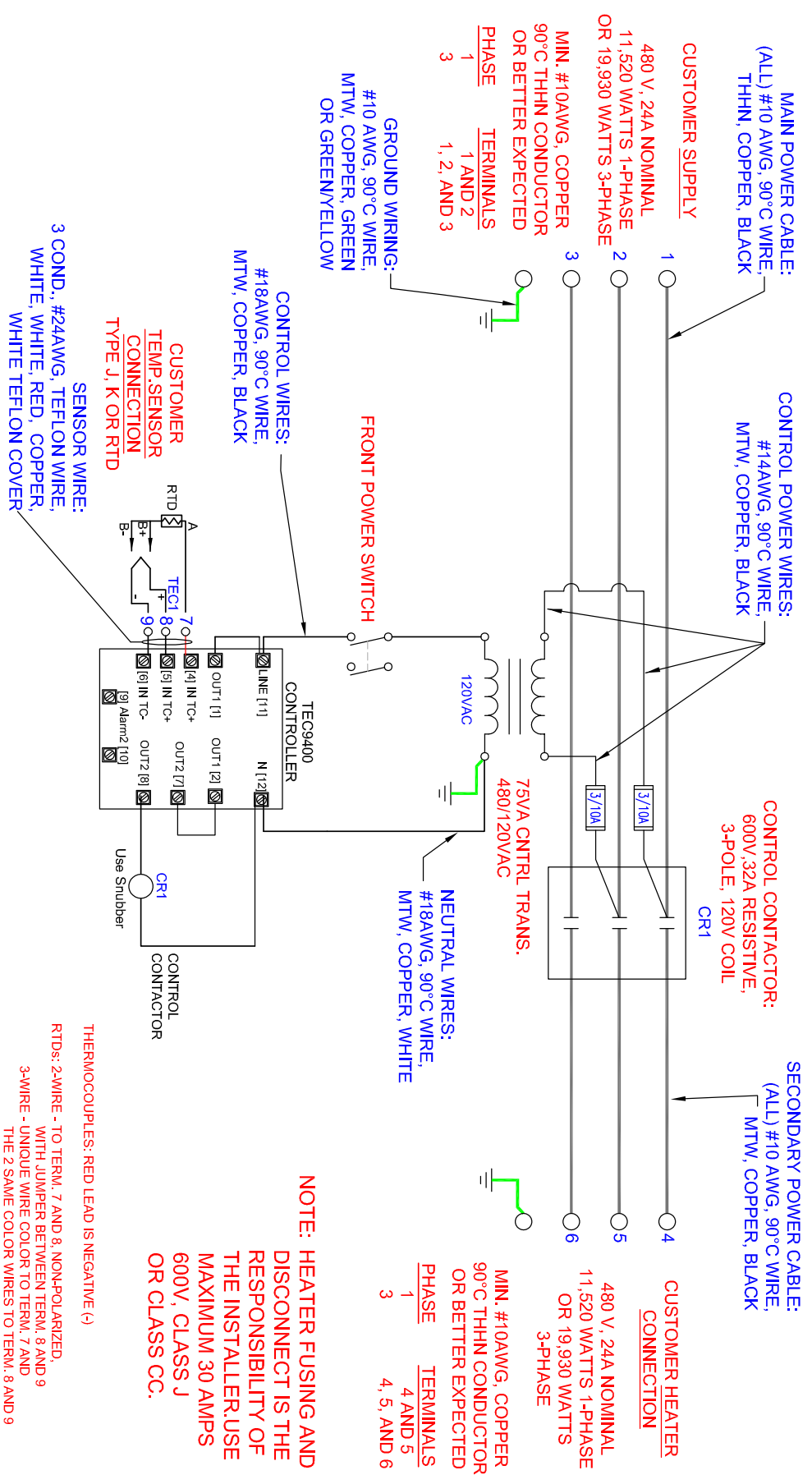

NOTE: TEC-9400  
 SETTINGS  
 Out2=AL1  
 A1Fn=deLo  
 A1Hy=0.2  
 A1DV=30

TOLERANCES UNLESS OTHERWISE SPECIFIED		TITLE:	
FRACTIONS	±1/64	INTERNAL WIRING DIAGRAM	
DECIMALS	±0.01	FOR PCM10081	
ANGLES	±.1°	DATE:	24A, 480VAC
SURFACE FINISH	-	SCALE:	12/18/19
CUSTOMER:	TEMPCO	THIRD ANGLE PROJECTION	REV. SHEET
			1 OF 1
		DRAWN BY:	JP
		APPROVED:	JT
		DRAWING NUMBER:	PCM10081-WD

PROPRIETARY AND CONFIDENTIAL: THIS DRAWING AND THE INFORMATION WITHIN ARE PROPRIETARY TO TEMPCO ELECTRIC HEATER CORPORATION AND ARE ISSUED IN STRICT CONFIDENCE ON THE CONDITION THAT THIS DRAWING AND ANY INFORMATION CONTAINED THEREIN SHALL NOT BE COPIED, USED FOR MANUFACTURE OR SALE, OR TRANSMITTED OR DISCLOSED TO A THIRD PARTY, IN WHOLE OR IN PART, WITHOUT THE PRIOR WRITTEN CONSENT OF TEMPCO ELECTRIC HEATER CORPORATION. REMOVING THIS DOCUMENT FROM TEMPCO WITHOUT TEMPCO'S WRITTEN CONSENT IS PROHIBITED. TEMPCO ELECTRIC HEATER CORPORATION. ALL RIGHTS RESERVED.		ECO #	NO.	REVISION	DATE	BY
	1	UPDATED	CONTROL SETTINGS	1/10/25	BPM	

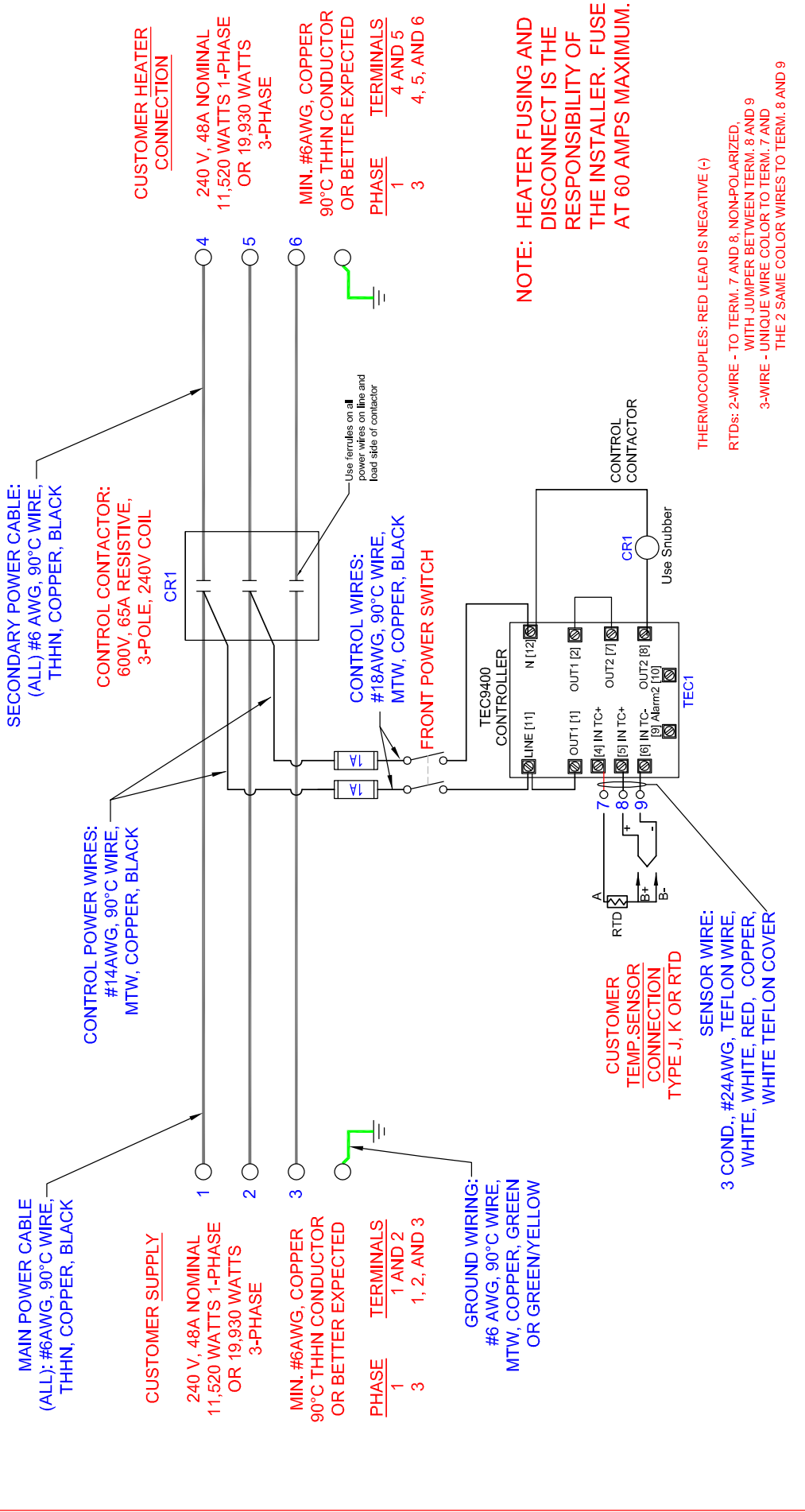

TOLERANCES UNLESS OTHERWISE SPECIFIED		TITLE:	
FRACTIONS ±1/64	DECIMALS .XX ±0.01	INTERNAL WIRING DIAGRAM FOR PCM10082	
ANGLES .XXX ±0.005	SURFACE FINISH ±1°	48A, 240VAC	
CUSTOMER:	TEMPCO	SCALE: -:-	DATE: 12/17/19
		THIRD ANGLE PROJECTION	DRAWN BY: JP
			APPROVED: JP
			REV. SHEET 1 OF 1
			DRAWING NUMBER: PCM10082-WD

NOTE: TEC-9400  
SETTINGS  
Out2=AL1  
A1Fn=dE.Lo  
A1Hy=0.2  
A1DV=30

**TEMPCO**  
TEMPCO Electric Heater Corporation  
607 N. Central Ave.  
Wood Dale, IL 60191-1452 U.S.A.  
Email: info@tempco.com

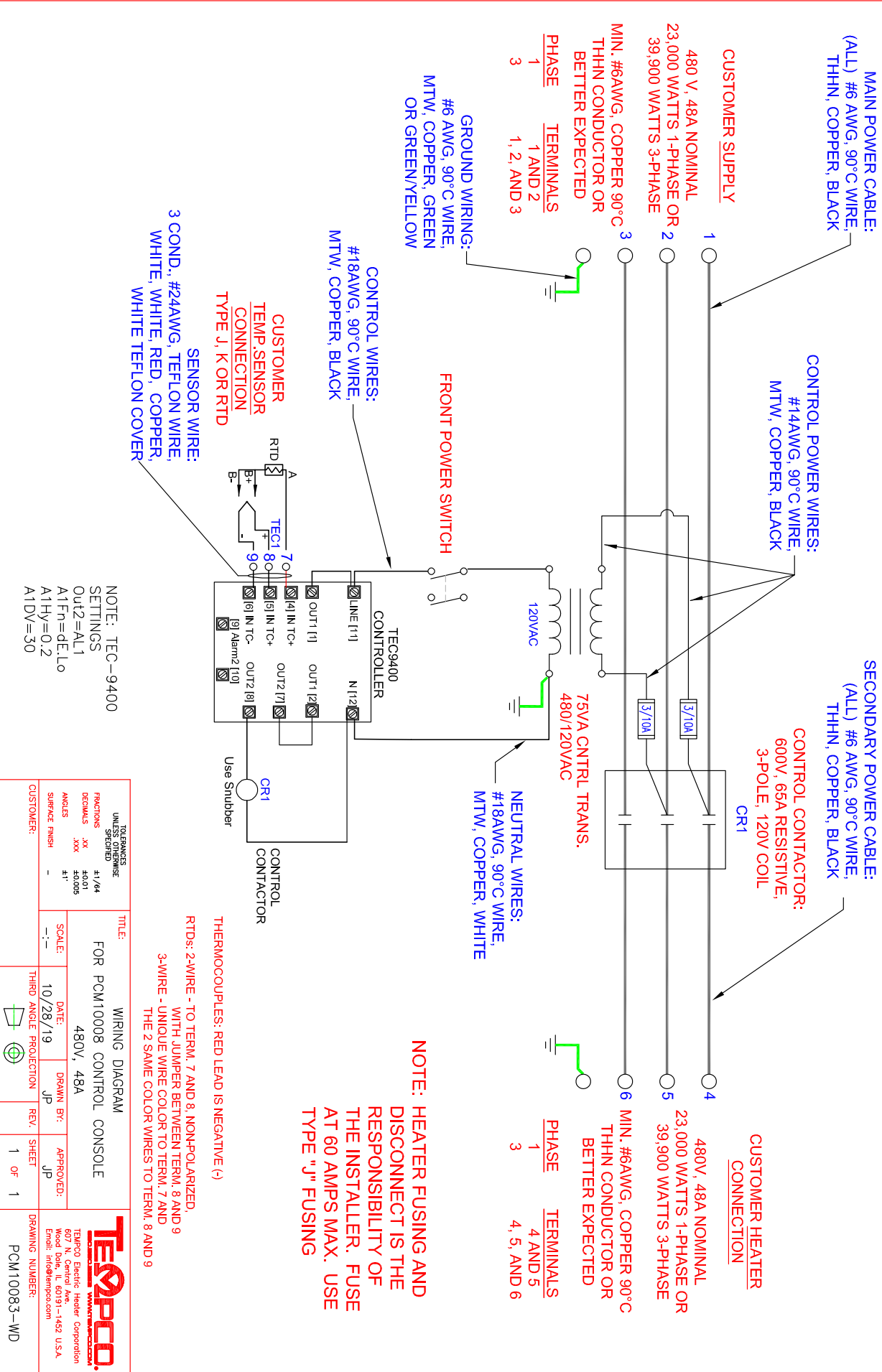

TOLERANCES UNLESS SPECIFIED		TITLE: WIRING DIAGRAM	
FRACTIONS	±1/64	FOR PCM10008 CONTROL CONSOLE	
DECIMALS	±0.01	DATE:	480V, 48A
ANGLES	.XXX	DRAWN BY:	JP
SURFACE FINISH	±.1"	APPROVED:	JP
CUSTOMER:		DATE:	10/28/19
		THIRD ANGLE PROJECTION	REV. 1
			SHEET 1 OF 1
		DRAWING NUMBER:	PCM10083-WD

# NOTES

---

# NOTES

---

## **RETURNS**

No product returns can be accepted without a completed Return Material Authorization (RMA) form.

## **TECHNICAL SUPPORT**

Technical questions and troubleshooting help is available from Tempco. When calling or writing please give as much background information on the application or process as possible.

E-mail: [techsupport@tempco.com](mailto:techsupport@tempco.com)

Phone: 630-350-2252

800-323-6859

**Note:** Information in this manual was deemed correct at the time of printing. The policy of Tempco is one of continuous development and product improvement, and we reserve the right to modify specifications and designs without prior notice. Not responsible for typographical errors.

# Custom Manufacturer Since 1972

ELECTRIC HEATING ELEMENTS • TEMPERATURE CONTROLS • SENSORS • PROCESS HEATING SYSTEMS

---

## HEAT THINGS UP!

With Thousands of Design Variations  
We Make Everything You Need.

Band Heaters  
Cast-In Heaters  
Radiant Heaters  
Flexible Heaters  
Process Heaters  
Temperature Control

Cartridge Heaters  
Coil & Cable Heaters  
Strip Heaters  
Tubular Heaters  
Instrumentation  
Temperature Sensors

---



607 N. Central Avenue Wood Dale, IL 60191-1452 USA  
P: 630-350-2252 Toll Free: 800-323-6859  
F: 630-350-0232 E: [info@tempco.com](mailto:info@tempco.com)  
[www.tempco.com](http://www.tempco.com)