

# TEMPCO®

## USER MANUAL

### TEC-2400/9400/8400/8450/7400/4400/6400 PID + Fuzzy Logic Process Controller



File #: E244198



RoHS



REACH



## Warning Symbol

This document contains notices that you should observe to ensure your own personal safety, as well as to protect the product and connected equipment. These notices are highlighted in the manual by a warning triangle and are marked as follows.

 The danger symbol indicates that death or severe personal injury may result if proper precautions are not taken. Do not proceed beyond a warning symbol until the indicated conditions are fully understood and met.

## Preface

Original equipment manufacturer reserves the right to change information available in this document without notice. Manufacturer is not liable for any damages incurred to equipment/personal during installation or use of equipment as explained in this document. User must acquire sufficient knowledge & skills prior to using equipment in the application and follow all the local standards & regulations to meet safety requirements.

## Copyright

The documentation and the software included with this product are copyrighted 2021 by Tempco Electric Heater Corp. All rights are reserved. Tempco reserves the right to make improvements in the products described in this manual at any time without notice.

No part of this manual may be reproduced/copied/translated or transmitted in any form or by any means without the prior written permission of Tempco. The information we supply is believed to be accurate and reliable as of this printing. However, we assume no responsibility for its use.

## NOTE

It is strongly recommended that a process should incorporate a Limit Control like a Tempco TEC-910 which will shut down the equipment at a preset process condition in order to avoid possible damage to products or systems.

## Contact Information

Wood Dale, IL, 60060, United States  
Tel: 888-268-6396 Fax: 630-350-0232  
Website: [www.tempco.com](http://www.tempco.com);  
Email: [info@tempco.com](mailto:info@tempco.com).

# TABLE OF CONTENTS

<b>1</b>	<b>INTRODUCTION</b>	<b>8</b>
1.1	Introduction	8
1.2	Features	8
1.3	Specifications	12
1.4	Hardware code	15
1.4.1	TEC-2400 Hardware code	15
1.4.2	TEC-9400 Hardware code	16
1.4.3	TEC-8400, TEC-8450, TEC-4400 Hardware code	17
1.4.4	TEC-7400 Hardware code	18
1.4.5	TEC-6400 Hardware code	19
1.4.6	Accessories	19
1.4.7	Related Products	19
1.5	Programming Port	20
1.6	Keys and Displays	20
1.7	Menu Flowchart	25
1.7.1	User Menu	26
1.7.2	Setup Menu	27
1.7.2.1	Basic Menu (bASE)	27
1.7.2.2	Output Menu (oUT)	28
1.7.2.3	Alarm Menu (ALRM)	29
1.7.2.4	Event Input Menu (EI)	30
1.7.2.5	User Select Menu (SEL)	30
1.7.2.6	Communication Menu (CoMM)	31
1.7.2.7	Current Transformer Input Menu (Ct)	31
1.7.2.8	Profile Menu (PRoF) (Also referred to as “ramp and Soak”)	32
1.7.3	Manual Mode Menu	33
1.7.4	Auto-Tuning Mode	33
1.7.5	Calibration Mode	34
1.8	Parameter Description	35
<b>2</b>	<b>INSTALLATION AND WIRING</b>	<b>54</b>
2.1	Unpacking	54
2.2	Mounting	54
2.2.1	TEC-2400 Dimension	55
2.2.2	TEC-9400 Dimension	56
2.2.3	TEC-8400 Dimension	58
2.2.4	TEC-8450 Dimension	60
2.2.5	TEC-7400 Dimension	62
2.2.6	TEC-4400 Dimension	64
2.2.7	TEC-6400 Dimension	66
2.3	Wiring	67
2.3.1	TEC-2400 Terminal Connection	68
2.3.2	TEC-9400 Terminal Connection	69
2.3.3	TEC-8400 & TEC-4400 Terminal Connection	70
2.3.4	TEC-8450 Terminal Connection	71

2.3.5	TEC-7400 Terminal Connection	72
2.3.6	TEC-6400 Terminal Connection	73
<b>2.4</b>	<b>Power Wiring</b>	<b>74</b>
<b>2.5</b>	<b>Sensor Installation</b>	<b>74</b>
<b>2.6</b>	<b>Sensor Input Wiring</b>	<b>75</b>
<b>2.7</b>	<b>Control Output Wiring</b>	<b>76</b>
2.7.1	Output 1	76
2.7.2	Output 2	78
<b>2.8</b>	<b>Alarm Wiring</b>	<b>79</b>
2.8.1	Alarm 1	79
2.8.2	Alarm 2	80
2.8.3	Alarm 3	81
2.8.4	Alarm 4	82
<b>2.9</b>	<b>Event Input Wiring</b>	<b>83</b>
<b>2.10</b>	<b>CT Input Wiring</b>	<b>84</b>
<b>2.11</b>	<b>RS-485 Data Communication</b>	<b>86</b>
<b>2.12</b>	<b>Retransmission Wiring</b>	<b>86</b>
<b>2.13</b>	<b>Remote Set Point Wiring</b>	<b>87</b>
<b>3</b>	<b>PROGRAMMING</b>	<b>88</b>
<b>3.1</b>	<b>User Security</b>	<b>88</b>
<b>3.2</b>	<b>Signal Input</b>	<b>88</b>
<b>3.3</b>	<b>Control Output</b>	<b>89</b>
3.3.1	Heat Only ON-OFF Control	89
3.3.2	Heat only P or PD Control	90
3.3.3	Heat only PID Control	90
3.3.4	Cool only Control	90
3.3.5	Other Setup Required	90
3.3.6	CPB Programming	90
3.3.7	DB Programming	91
3.3.8	Output 2 ON-OFF Control (Alarm function)	91
<b>3.4</b>	<b>Soft-Start</b>	<b>92</b>
<b>3.5</b>	<b>Alarm</b>	<b>93</b>
3.5.1	Alarm Types	93
3.5.2	Alarm Modes	94
3.5.2.1	Normal Alarm: ALMD = NORM	94
3.5.2.2	Latching Alarm: ALMD = LTCH	94
3.5.2.3	Holding Alarm: ALMD = HOLD	94
3.5.2.4	Latching / Holding Alarm: ALMD = LT.HO	94
3.5.2.5	Set Point Holding Alarm: ALMD = SP.HO	95
3.5.3	Alarm Delay	95
3.5.4	Alarm Failure Transfer	95
<b>3.6</b>	<b>User Select Menu Configuration</b>	<b>95</b>
<b>3.7</b>	<b>Ramp</b>	<b>96</b>
3.7.1	Ramping Example without Dwell Timer	96
<b>3.8</b>	<b>Dwell Timer</b>	<b>97</b>

<b>3.9</b>	<b>User Calibration</b>	<b>97</b>
<b>3.10</b>	<b>Digital Filter</b>	<b>98</b>
<b>3.11</b>	<b>Failure Transfer</b>	<b>99</b>
3.11.1	Output 1 Failure Transfer	99
3.11.2	Output 2 Failure Transfer	99
3.11.3	Alarm Failure Transfer	99
<b>3.12</b>	<b>Auto-Tuning</b>	<b>99</b>
3.12.1	Auto-Tuning Operation Steps	100
3.12.2	Auto-Tuning Error	100
3.12.3	Solution for an Auto-Tuning Error	100
<b>3.13</b>	<b>Manual Tuning</b>	<b>101</b>
<b>3.14</b>	<b>Manual Control</b>	<b>102</b>
3.14.1	Exit Manual Control	102
<b>3.15</b>	<b>Setting Controller to Factory Default</b>	<b>102</b>
<b>3.16</b>	<b>Data Communication (Modbus Register Addresses and Programming in a separate manual)</b>	<b>102</b>
3.16.1	RS-485 Setup	102
<b>3.17</b>	<b>Retransmission</b>	<b>103</b>
<b>3.18</b>	<b>Heater Current Monitoring</b>	<b>103</b>
<b>3.19</b>	<b>Event Input</b>	<b>104</b>
3.19.1	Event Input Functions (See below for descriptions)	104
<b>3.20</b>	<b>Remote Set Point</b>	<b>105</b>
<b>3.21</b>	<b>Ramp and Soak Program (See descriptions of below settings on following pages)</b>	<b>105</b>
3.21.1	PROF	105
3.21.2	RUN	106
3.21.2.1	StAR	106
3.21.2.2	CoNt	106
3.21.2.3	PV	106
3.21.2.4	Hold	106
3.21.2.5	StoP	106
3.21.3	RMPU	106
3.21.4	STAR	106
3.21.5	END	106
3.21.5.1	SP1	106
3.21.6	PFR	107
3.21.6.1	CONT	107
3.21.6.2	PV	108
3.21.6.3	SP1	109
3.21.6.4	OFF	109
3.21.7	Holdback	109
3.21.8	CYCL	109
3.21.9	Running, Holding and Stopping a Profile	109
3.21.10	Viewing and Modifying the Profile Progress	109
3.21.11	Configuring the Profile	109
3.21.11.1	Profile Segment Parameters	110
3.21.11.1.1	Target Set point	110
3.21.11.1.2	Ramp Time	110
3.21.11.1.3	Soak Time	110

<b>4</b>	<b>APPLICATIONS</b>	<b>111</b>
<b>4.1</b>	<b>Heat Only Control with Dwell Timer</b>	<b>111</b>
<b>4.2</b>	<b>Cool Only Control</b>	<b>112</b>
<b>4.3</b>	<b>Heat and Cool Control</b>	<b>113</b>
<b>4.4</b>	<b>Ramp &amp; Dwell</b>	<b>114</b>
4.4.1	Temperature Cycling Chamber	114
4.4.2	Programmable Bread Baking Oven	116
<b>4.5</b>	<b>Remote Set Point</b>	<b>117</b>
<b>4.6</b>	<b>Retransmission Application</b>	<b>118</b>
<b>4.7</b>	<b>Ramp &amp; Soak Profile in Heat Treatment Chamber</b>	<b>118</b>
<b>4.8</b>	<b>Parameter Availability Table</b>	<b>119</b>

## TABLE OF TABLES

1-1.	CONTROLLER MODELS	8
2-1.	ENVIRONMENTAL SPECIFICATION	54
3-1.	USER ACCESS RIGHTS	88
3-2.	CONTROL MODE	89
3-3.	PID PARAMETER ADJUSTMENT GUIDE	101

## TABLE OF FIGURES

1-1.	FUZZY PID CONTROL	9
1-2.	PROGRAMMING PORT	10
1-3.	PROGRAMMING PORT	20
1-4.	TEC-2400 FRONT PANEL KEYS AND DISPLAY	21
1-5.	TEC-9400 FRONT PANEL KEYS AND DISPLAY	21
1-6.	TEC-8400 FRONT PANEL KEYS AND DISPLAY	22
1-7.	TEC-8450 FRONT PANEL KEYS AND DISPLAY	22
1-8.	TEC-7400 FRONT PANELS KEYS AND DISPLAY	23
1-9.	TEC-4400 FRONT PANEL KEYS AND DISPLAY	23
1-10.	TEC-6400 FRONT PANEL KEYS & DISPLAY	24
1-11.	HOW CHARACTERS ARE DISPLAYED ON THE LCD SCREEN	24
2-1.	TEC-2400 DIMENSIONS WITH CLAMP	55
2-2.	TEC-2400 DIMENSION WITHOUT CLAMP	55
2-3.	TEC-9400 DIMENSION WITH CLAMP	56
2-4.	TEC-9400 DIMENSION WITHOUT CLAMP	57
2-5.	TEC-8400 DIMENSION WITH CLAMP	58
2-6.	TEC-8400 DIMENSION WITHOUT CLAMPS	59
2-7.	TEC-8450 DIMENSION WITH CLAMPS	60
2-8.	TEC-8450 DIMENSION WITHOUT CLAMP	61
2-9.	TEC-7400 DIMENSION WITH CLAMP	62
2-10.	TEC-7400 DIMENSION WITHOUT CLAMP	63
2-11.	TEC-4400 DIMENSION WITH CLAMPS	64
2-12.	TEC-4400 DIMENSION WITHOUT CLAMP	65
2-13.	TEC-6400 DIMENSION	66
2-14.	LEAD TERMINAL FOR ALL MODELS EXCEPT TEC-2400	67
2-15.	LEAD TERMINAL FOR TEC-2400	67

2-16.TEC-2400 REAR TERMINAL CONNECTION .....	68
2-17. TEC-9400 REAR TERMINAL CONNECTION .....	69
2-18. TEC-8400 & TEC-4400 REAR TERMINAL CONNECTION .....	70
2-19.TEC-8450 REAR TERMINAL CONNECTION .....	71
2-20.TEC-7400 REAR TERMINAL CONNECTION .....	72
2-21.TEC-6400 TERMINAL CONNECTION.....	73
2-22.POWER WIRING.....	74
2-23.SENSOR INPUT WIRING .....	75
2-24. OUTPUT 1 RELAY TO DRIVE LOAD .....	76
2-25. OUTPUT 1 RELAY TO DRIVE CONTACTOR.....	76
2-26. OUTPUT1 PULSED VOLTAGE TO DRIVE SSR.....	77
2-27. OUTPUT 1 LINEAR CURRENT CONTROL.....	77
2-28. OUTPUT 1 LINEAR VOLTAGE CONTROL.....	77
2-29. OUTPUT 2 RELAY TO DRIVE LOAD .....	78
2-30. OUTPUT 2 RELAY TO DRIVE CONTACTOR.....	78
2-31. OUTPUT 2 PULSED VOLTAGE TO DRIVE SSR.....	78
2-32. OUTPUT 2 LINEAR CURRENT CONTROL.....	79
2-33. OUTPUT 2 LINEAR VOLTAGE CONTROL.....	79
2-34. ALARM 1 OUTPUT TO DRIVE LOAD .....	79
2-35. ALARM 1 OUTPUT TO DRIVE CONTACTOR.....	80
2-36. ALARM 2 OUTPUT TO DRIVE LOAD .....	80
2-37. ALARM 2 OUTPUT TO DRIVE CONTACTOR.....	80
2-38. ALARM 3 OUTPUT TO DRIVE LOAD .....	81
2-39. ALARM 3 OUTPUT TO DRIVE CONTACTOR.....	81
2-40. ALARM 4 OUTPUT TO DRIVE LOAD .....	82
2-41. ALARM 4 OUTPUT TO DRIVE CONTACTOR IN TEC-4400 .....	82
2-42. EVENT INPUT WIRING .....	83
2-43. CT INPUT WIRING FOR SINGLE PHASE HEATER.....	84
<i>-44.CT INPUT WIRING FOR 3PHASE HEATER .....</i>	<i>85</i>
2-45.RS-485 WIRING.....	86
2-46. RETRANSMISSION WIRING.....	86
2-47.REMOTE SET POINT .....	87
3-1.HEAT ONLY ON-OFF CONTROL .....	89
3-2.OUTPUT 2 DEVIATION HIGH ALARM.....	91
3-3.OUTPUT 2 PROCESS LOW ALARM .....	91
3-4.SOFT START FUNCTION .....	92
3-5.CONFIGURABLE USER MENU .....	96
3-6.RAMP FUNCTION.....	96
3-7.DWELL TIMER.....	97
3-8.TWO POINT USER CALIBRATION .....	98
3-9.FILTER CHARACTERISTICS.....	98
3-10. EFFECTS OF PID ADJUSTMENT .....	101
3-11.POWER FAILURE RECOVERY FROM PROFILE AT DWELL SEGMENT.....	107
3-12.POWER FAILURE RECOVERY FROM PROFILE AT RAMP SEGMENT .....	107
3-13.POWER FAILURE RECOVERY FROM PV DURING A DWELL SEGMENT .....	108
3-14.POWER FAILURE RECOVERY FROM PV AT RAMP SEGMENT .....	108
4-1.HEAT ONLY CONTROL WITH DWELL TIMER .....	111
4-2.COOLING CONTROL.....	112
4-3.HEAT COOL CONTROL .....	113
4-4.RAMP & DWELL TEMPERATURE CYCLING CHAMBER.....	115
4-5.TEMPERATURE PROFILE FOR TEMPERATURE CYCLING CHAMBER .....	115
4-6.BREAD BAKING OVEN.....	116
<i>4-7.TEMPERATURE PROFILE OF BAKING OVEN .....</i>	<i>116</i>

# 1 Introduction

## 1.1 Introduction

The new generation of low-cost PID microprocessor-based Fuzzy logic controllers incorporate two bright easy-to-read LCD Displays which indicate Process Value (PV) and Set point (SP). The Fuzzy Logic technology incorporated on these series controllers enables a process to reach a predetermined set point in the shortest time with minimum of overshoot during start up (Power ON) or external load disturbances (example: an oven door being opened).

Different controller models in this series are as follows:

Model No	Mounting Type	DIN Size	Dimensions LxWxD" (mm)	Depth Behind Panel in(mm)
TEC-2400	Panel Mount	1/32 DIN	1 x 1 7/8 x 3 3/8" (24x48x85)	3" (76)
TEC-9400	Panel Mount	1/16DIN	1 7/8 x 1 7/8 x 2 5/16" (48x48x59)	2" (50)
TEC-8400/TEC-8450	Panel Mount	1/8 DIN	1 7/8 x 3 3/4 x 2 5/16" (48x96x59)	2" (50)
TEC-7400	Panel Mount	3/16 DIN	2 27/32 x 2 27/32 x 2 5/16" (72x72x59)	2" (50)
TEC-4400	Panel Mount	1/4 DIN	3 3/4 x 3 3/4 x 2 5/16" (96x96x59)	2" (50)
TEC-6400	DIN RAIL		7/8 x 3 3/4 x 3 5/32" (22.5x96x80)	

### 1-1. Controller Models

These controllers are powered by an 11-26 VDC/VAC or 90-250 VDC/VAC supply. The second output can be used as a cooling control or an alarm. Both outputs can be ordered with a 5VDC or 14VDC pulsed logic output, or linear current or linear voltage to drive an external device. There are six types of alarms + a dwell timer that can be configured for the third output. The controllers are fully programmable for **Linear current, Linear Voltage, PT100 and thermocouple types J, K, T, E, B, R, S, N, L, U, P, C, and D**. The input signal is digitized by using an 18-bit A to D converter. It's fast sampling rate allows the controller to control fast processes.

## 1.2 Features

The new generation of low cost PID controllers have many features, some of which are listed below.

- ❖ LCD Display
- ❖ Fast Sampling Rate 200m sec
- ❖ Universal Input
- ❖ Fuzzy Logic +PID Technology
- ❖ Possibility of both RS-485 and analog retransmission

- ❖ 16 Segments of Ramp & Soak
- ❖ Current Transformer (CT) Inputs for heater break detection
- ❖ Up to 6 Event Inputs
- ❖ Remote Set point
- ❖ Auto-Tuning
- ❖ Lockout Protection
- ❖ Soft Start function

### LCD Display

All the controllers in this series will be equipped with a high brightness LCD Display.

### Fuzzy PID Technology

By using proprietary Fuzzy modified PID technology, the control loop will minimize overshoot and undershoot in the shortest allowable time. The following diagram is a comparison of results with and without Fuzzy Logic technology.

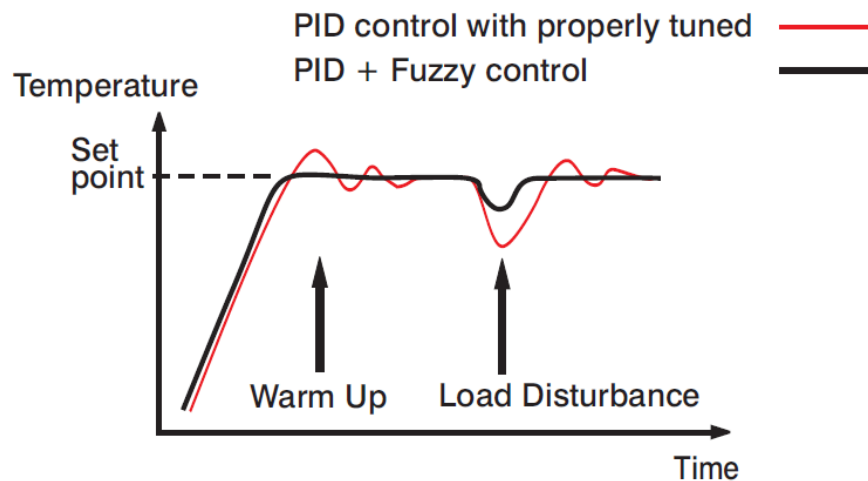

**1-1.Fuzzy PID Control**

### High Accuracy

These controllers are manufactured using an technology which contains an 18-bit A to D converter for high resolution measurement (true 0.1°F resolution for thermocouple and PT100 sensors) and a 15-bit D to A converter for a linear current or voltage control output.

### Fast Sampling Rate

The sampling rate of the A to D converter reaches up to 200 msec. This fast sampling rate allows control of fast processes.

### Digital Communication

The controllers can be equipped with an optional RS-485 interface to provide digital communication. By using twisted pair wires, up to 247 units can be connected together via an RS-485 interface to a host computer.

## Programming Port

A Micro USB programming port is available for automatic configuration, calibration and firmware upgrades without the need to access the keys on front panel.

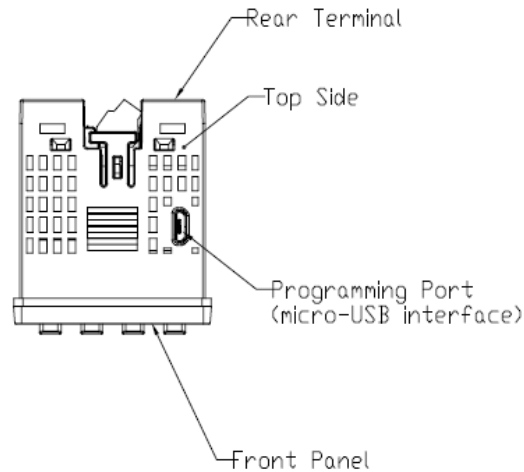

### 1-2.Programming Port

#### Auto-tuning

The auto-tuning function allows the user to simplify initial setup for a new system. A clever algorithm is provided to obtain an optimal set of control parameters for the process. It can be applied either as the process is warming up (cold start) or when the process is in a steady state (warm start).

#### Lockout Protection

According to user security requirements, one of four lockout levels (NONE, ALL, USER, SET) can be selected to prevent certain settings from being changed.

#### Bumpless Transfer

Bumpless transfer allows the controller to continue to control by using its previous output value if the input sensor breaks. Hence, the process can be controlled **temporarily** as if the sensor is functioning normally.

#### Soft-start Ramp

The ramping function can be performed during power up as well as any time the set point is changed. It can ramp up or ramp down. The process value will reach the set point within a predetermined constant rate ( $^{\circ}/\text{sec}$ ,  $^{\circ}/\text{m}$ ).

#### Soft-start

The soft start function allows the ability to limit the power output for a programmable time (SFT) or up to a programmed threshold value (SFTH). The soft start function will work until either one of the two are reached. When soft start function is running, the lower display will alternate between the message "SFS" and the setpoint.

**Event Input**

Event Inputs are available as an option to change certain functions and the set point. There are 6 Event Inputs that are available in the TEC-4400, TEC-8400 and TEC-8450 models. There are two event Inputs are that available in the TEC-9400, TEC-7400 controllers, and one event input is available in the TEC-2400, TEC-6400 controllers.

**Remote Set Point**

A Remote Set point function is available to vary the set point by using either a linear voltage or current input. A remote set point is available in select models.

**CT Input**

CT Input Options are available to detect if a heater breaks or to monitor current for an alarm output. There are a maximum of two CT inputs available.

**Analog Retransmission**

Analog retransmission is available as an option.

**Profile (Ramp/Soak) Segments**

These controllers have the option for Ramp and Soak Profiles with 16 segments total. These segments can be used as 4 Profiles with each 4 segments or 2 Profiles with each 8 segments or one profile with 16 segments. This option is not available with the TEC-2400, TEC-9400 and TEC-6400 models.

### 1.3 Specifications

Specification	TEC-2400	TEC-9400	TEC-8400	TEC-8450	TEC-7400	TEC-4400	TEC-6400
Power Supply	90 to 250VAC, 47 to 63Hz, 20 to 28 VAC, 47-63Hz / 11 to 40 VDC						
Power Consumption	TEC-2400/TEC-6400: 8VA, 4W Maximum., TEC-9400: 10VA, 5W Maximum., TEC-7400/TEC-8400/TEC-8450/TEC-4400: 12VA, 6W Maximum						
<b>Signal Input</b>							
Type	Thermocouple(J,K,T,E,B,R,S,N,L,U,P,C,D), RTD(PT100(DIN), PT100(JIS)), Current(mA), Voltage(Volts)						
Resolution	18 Bits						
Sampling Rate	5 Times / Second (200msec)						
Maximum Rating	-2VDC minimum, 12VDC maximum						
Input Characteristics	<b>Type</b>	<b>Range</b>		<b>Accuracy @ 25°C</b>		<b>Input Impedance</b>	
	J	-120°C to 1000°C (-184°F to 1832°F)		±2°C		2.2 MΩ	
	K	-200°C to 1370°C (-328°F to 2498°F)		±2°C		2.2 MΩ	
	T	-250°C to 400°C (-418°F to 752°F)		±2°C		2.2 MΩ	
	E	-100°C to 900°C (-148°F to 1652°F)		±2°C		2.2 MΩ	
	B	0°C to 1820°C (32°F to 3308°F)		±2°C (200°C to 1800°C)		2.2 MΩ	
	R	0°C to 1767.8°C (32°F to 3214°F)		±2°C		2.2 MΩ	
	S	0°C to 1767.8°C (32°F to 3214°F)		±2°C		2.2 MΩ	
	N	-250°C to 1300°C (-418°F to 2372°F)		±2°C		2.2 MΩ	
	L	-200°C to 900°C (-328°F to 1652°F)		±2°C		2.2 MΩ	
	U	-200°C to 600°C (-328°F to 1112°F)		±2°C		2.2 MΩ	
	P	0°C to 1395°C (32°F to 2543°F)		±2°C		2.2 MΩ	
	C	0°C to 2300°C (32°F to 4172°F)		±2°C		2.2 MΩ	
	D	0°C to 2300°C (32°F to 4172°F)		±2°C		2.2 MΩ	
		PT100(DIN)	-200°C to 850°C (-328°F to 1562°F)		±0.4°C		1.3KΩ
	PT100(JIS)	-200°C to 600°C (-328°F to 1112°F)		±0.4°C		1.3KΩ	
	mA	-3mA to 27mA		±0.05%		2.5Ω	
	VDC	-1.3VDC to 11.5VDC		±0.05%		1.5MΩ	
Temperature Effect	1.5μV /°C for all inputs except mA input, 3.0μV /°C for mA						
Sensor Lead Resistance Effect	<b>Thermocouple:</b> 0.2 μV /°Ω; <b>3-wire RTD:</b> 2.6°C /Ω of Difference of Resistance of two leads <b>2-wire RTD:</b> 2.6°C /Ω of Sum of Resistance of two leads						
Burn-out Current	200nA						
Common Mode Rejection Ratio(CMRR)	120 dB						
Normal Mode Rejection Ratio (NMRR)	55dB						
Sensor Break Detection	Sensor open for Thermocouple, RTD and mV inputs, Sensor short for RTD input, Below 1mA for 4-20mA input, Below 0.25VDC for 1 - 5VDC input, Not available for other inputs.						
Sensor Break Response Time	Within 4 seconds for Thermocouple, RTD and mV inputs, 0.1 second for 4-20mA and 1 - 5VDC inputs.						
<b>Remote Set Point Input</b>							
Type	Linear Current, Linear Voltage						
Range	-3mA to 27mA, -1.3VDC to 11.5VDC						
Accuracy	±0.05 %						
Remote Set Point Option	Not Available	Not Available	Available	Available	Available	Available	Not Available
Input Impedance	Current: 2.5Ω, Voltage: 1.5MΩ						
Resolution	18 Bits						
Sampling Rate	1.66 Times/Second						

Specification	TEC-2400	TEC-9400	TEC-8400	TEC-8450	TEC-7400	TEC-4400	TEC-6400
Maximum Rating	280mA maximum for Current Input, 12VDC Maximum for Voltage Input						
Temperature Effect	$\pm 1.5\mu\text{V}/^\circ\text{C}$ for Voltage Input , $\pm 3.0\mu\text{V}/^\circ\text{C}$ for Current Input						
Sensor Break Detection	Below 1mA for 4-20mA input, Below 0.25VDC for 1 - 5VDC input, Not available for other inputs.						
Sensor Break Responding Time	0.1 Second						
<b>Event Input</b>							
Number of Event Inputs	1	2	6	6	2	6	1
Logic Low	-10VDC minimum, 0.8VDC maximum.						
Logic High	2VDC minimum, 10VDC maximum						
Functions	See availability table						
<b>CT Input</b>							
CT Type	TEC99998						
Accuracy	$\pm 5\%$ of Full scale Reading $\pm 1$ Digit.						
Input Impedance	294 $\Omega$						
Measurement Range	0 to 50AAC						
Output of CT	0 to 5VDC						
CT Mounting	Wall (Screw) Mount						
Sampling Rate	1 Time/Second						
<b>Output 1 /Output 2</b>							
Type	Relay, Pulsed Voltage, Linear Voltage or Linear Current						
Relay Rating	2A,240V AC,200000 Life Cycles for Resistive Load						
Pulsed Voltage	Source Voltage 5VDC,Current Limiting Resistance 66 $\Omega$						
Linear Output Resolution	15 Bits						
Linear Output Regulation	0.02% for full load change						
Linear Output Cycle Time	0.1 Sec (Stable to 99.9%)						
Isolation Breakdown Voltage	1000 VAC						
Temperature Effect	$\pm 0.01\%$ of Span/ $^\circ\text{C}$						
Load Capacity of Linear Output	Linear Current: 500 $\Omega$ max., Linear Voltage: 10K $\Omega$ min						
<b>Alarm</b>							
Relay Type	Form A						
Maximum Rating	2A,240VAC,200000 Life Cycles for Resistive Load						
Alarm Functions	Dwell Timer, Deviation Low, Deviation High, Deviation Band Low, Deviation Band High, Process High, Process Low						
Alarm Mode	Latching, Hold, Normal, Latching/Hold						
Dwell Timer	0.1 to 4553.6 Minutes						
<b>Data Communication</b>							
Interface	RS-485						
Protocol	Modbus RTU (Secondary Mode)						
Address	1 to 247						
Baud Rate	2.8KBPS to 115.2KBPS						
Parity Bit	None, Even or Odd						
Stop Bit	1 or 2 Bits						
Data Length	7 or 8 Bits						
Communication Buffer	160 Bytes						
<b>Analog Retransmission</b>							
Output Signal	4-20mA, 0-20 mA,0 - 10VDC						
Resolution	15 Bits						

Specification	TEC-2400	TEC-9400	TEC-8400	TEC-8450	TEC-7400	TEC-4400	TEC-6400
Accuracy	±0.05% of Span ± 0.0025% / °C						
Load Resistance	0 to 500Ω for current output , 10KΩ minimum for Voltage Output						
Output Regulation	0.01% for full load change						
Output Setting Time	0.1Second (stable to 99.9%)						
Isolation Breakdown	1000VAC min						
Integral Linearity Error	±0.005% of span						
Temperature Effect	±0.0025% of span /°C						
Saturation Low	0mA or 0VDC						
Saturation High	22.2mA or 5.55V,11.1V min						
Linear Output Ranges	0 - 22.2mA (0 - 20mA/4 - 20mA), 0 - 5.55VDC (0 - 5VDC, 1 - 5VDC),0 - 11.1VDC (0 - 10VDC)						
<b>User Interface</b>							
Keypad	4 Keys						
Display Type	4 Digit LCD Display						
No of Display	2	2	3	3	3	3	2
Upper Display Size	0.4"(10mm)	0.58"(15mm)	0.7"(17.7mm)	0.7"(17.7mm)	0.58"(15mm)	0.98"(25mm)	0.31"(8mm)
Lower Display Size	0.19"(4.8mm)	0.3"(7.8mm)	0.4"(11.2mm)	0.4"(11.2mm)	0.32"(8.3mm)	0.55"(14mm)	0.25"(6.5mm)
<b>Programming Port</b>							
Interface	Micro USB						
PC Communication Function	Automatic Setup, Calibration and Firmware upgrade						
<b>Control Mode</b>							
Output 1	Reverse (Heating) or Direct (Cooling) Action						
Output 2	PID cooling control, Cooling P band 50~300% of PB, Dead band -36.0 ~ 36.0 % of PB						
ON-OFF	0.1~50.0°C (0.1~90.0°F) hysteresis control ( P band = 0)						
P or PD	0 - 100.0 % offset adjustment						
PID	Fuzzy logic modified Proportional band 0.1 ~ 500.0°C(0.1~900.0°F), Integral time 0 – 3600 Secs, Derivative Time 0 - 360.0 Secs						
Cycle Time	0.1 to 90.0 Seconds						
Manual Control	Heat(MV1) and Cool(MV2)						
Auto-Tuning	Cold Start and Warm Start						
Failure Mode	Auto transfer to manual mode while sensor break or A-D Converter damage						
Ramping Control	0 to 500.0°C (0 to 900.0°F)/Minute or 0 to 500.0°C (0 to 900.0°F)/Hour Ramp Rate						
<b>Digital Filter</b>							
Function	First Order						
Time Constant	0,0.2, 0.5, 1, 2, 5, 10, 20, 30, 60 Seconds, Programmable						
<b>Profiler</b>							
Availability	No	No	Option	Option	Option	Option	No
No of Programs	NA	NA	1Program with 16 Segments or 2Programs with each 8 Segments or 4Programs with each 4 Segments				NA
<b>Environmental and Physical Specifications</b>							
Operating Temperature	-10°C to 50°C						
Storage Temperature	-40°C to 60°C						
Humidity	0 to 90 % RH (Non-Condensing)						
Altitude	2000 Meters Maximum						
Pollution	Degree II						
Insulation Resistance	20MΩ Minimum(@500V DC)						
Dielectric Strength	2000VAC,50/60 Hz for 1 Minute						
Vibration Resistance	10 to 55 Hz , 10m/s² for 2 Hours						
Shock Resistance	200 m/s²(20g)						
Housing	Flame Retardant Polycarbonate						
Mounting	Panel	Panel	Panel	Panel	Panel	Panel	DIN Rail

Specification	TEC-2400	TEC-9400	TEC-8400	TEC-8450	TEC-7400	TEC-4400	TEC-6400
Dimensions (W*H*D) (mm)	48*24*92	48*48*59	48*96*59	96*48*59	72*72*59	96*96*59	22.5*96*83
Depth Behind Panel (mm)	84	50	50	50	50	50	
Cut Out Dimensions (mm)	45*22.2	45*45	45*92	92*45	68*68	92*92	
Weight (grams)	120	160	220	220	190	290	160
<b>Approval Standards</b>							
Safety	UL61010-1, CSA 22.2 No.61010-1-12, EN61010-1 ( IEC1010-1 )						
Protective Class	IP50 for the front panel, IP20 for rear terminals and housing. All indoor use.						
EMC	EN61326						

## 1.4 Hardware code

### 1.4.1 TEC-2400 Hardware code

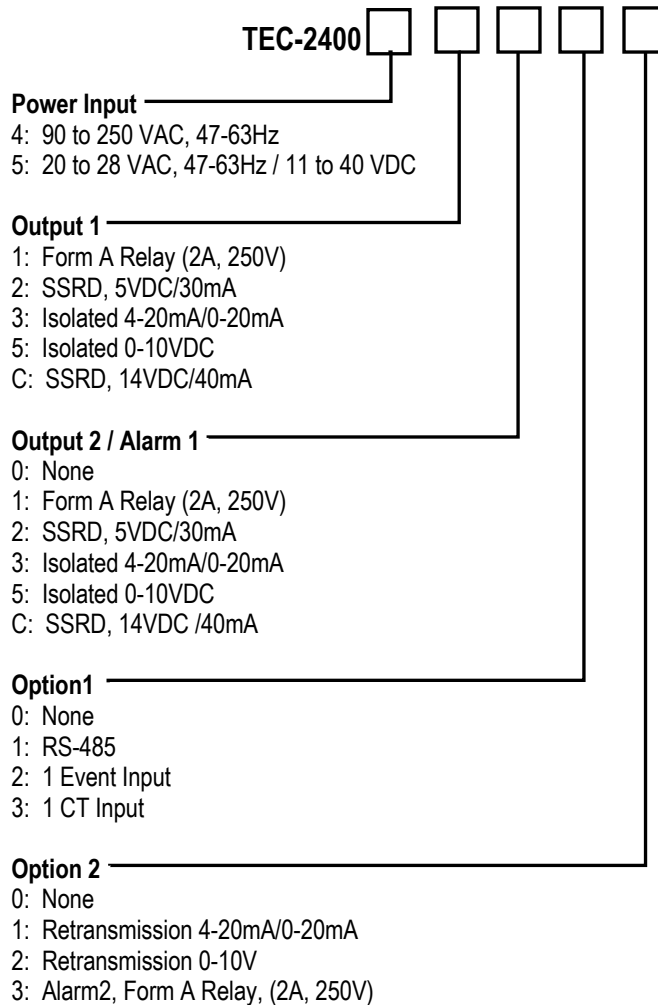

## 1.4.2 TEC-9400 Hardware code

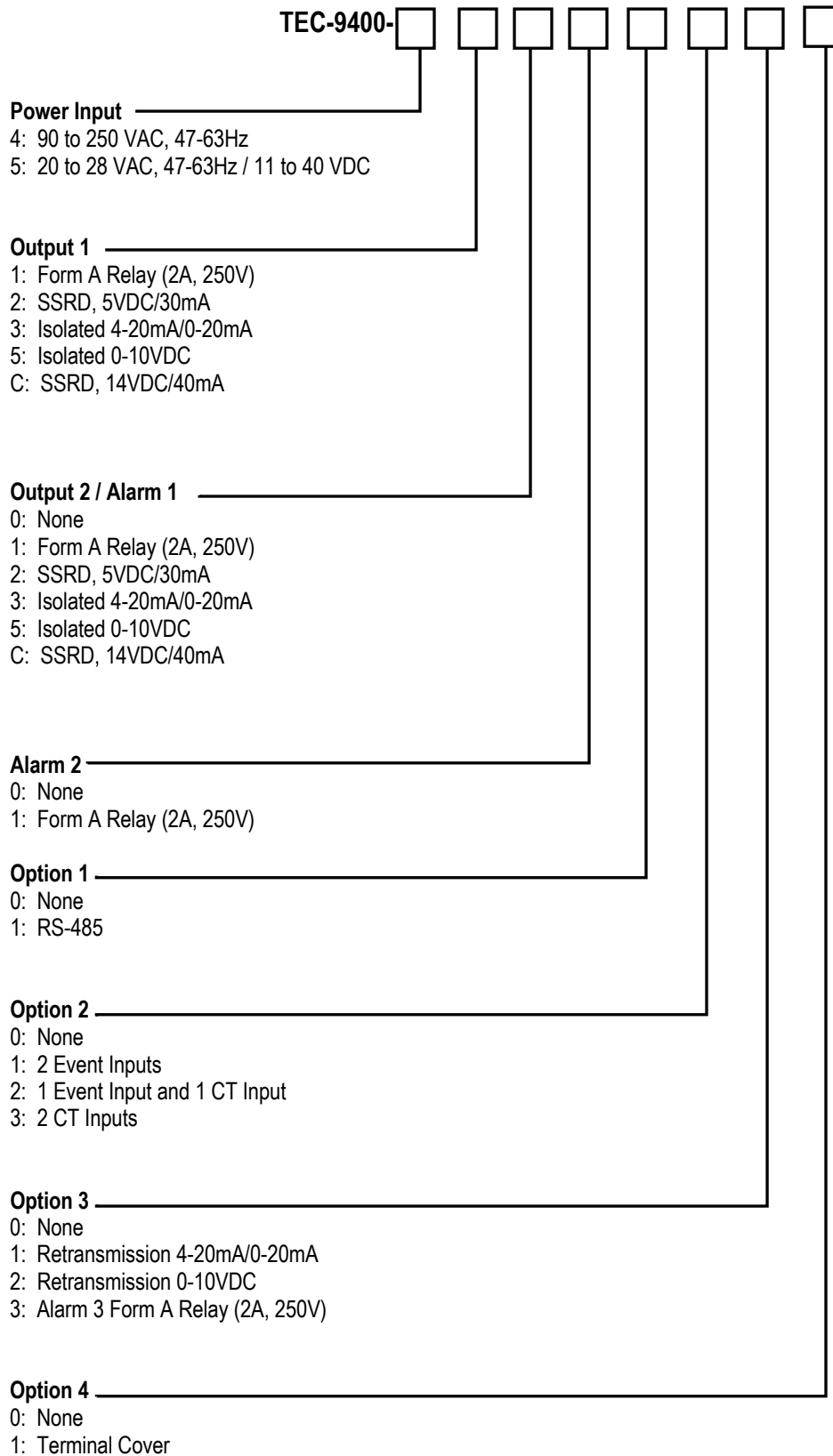

### 1.4.3 TEC-8400, TEC-8450, TEC-4400 Hardware code

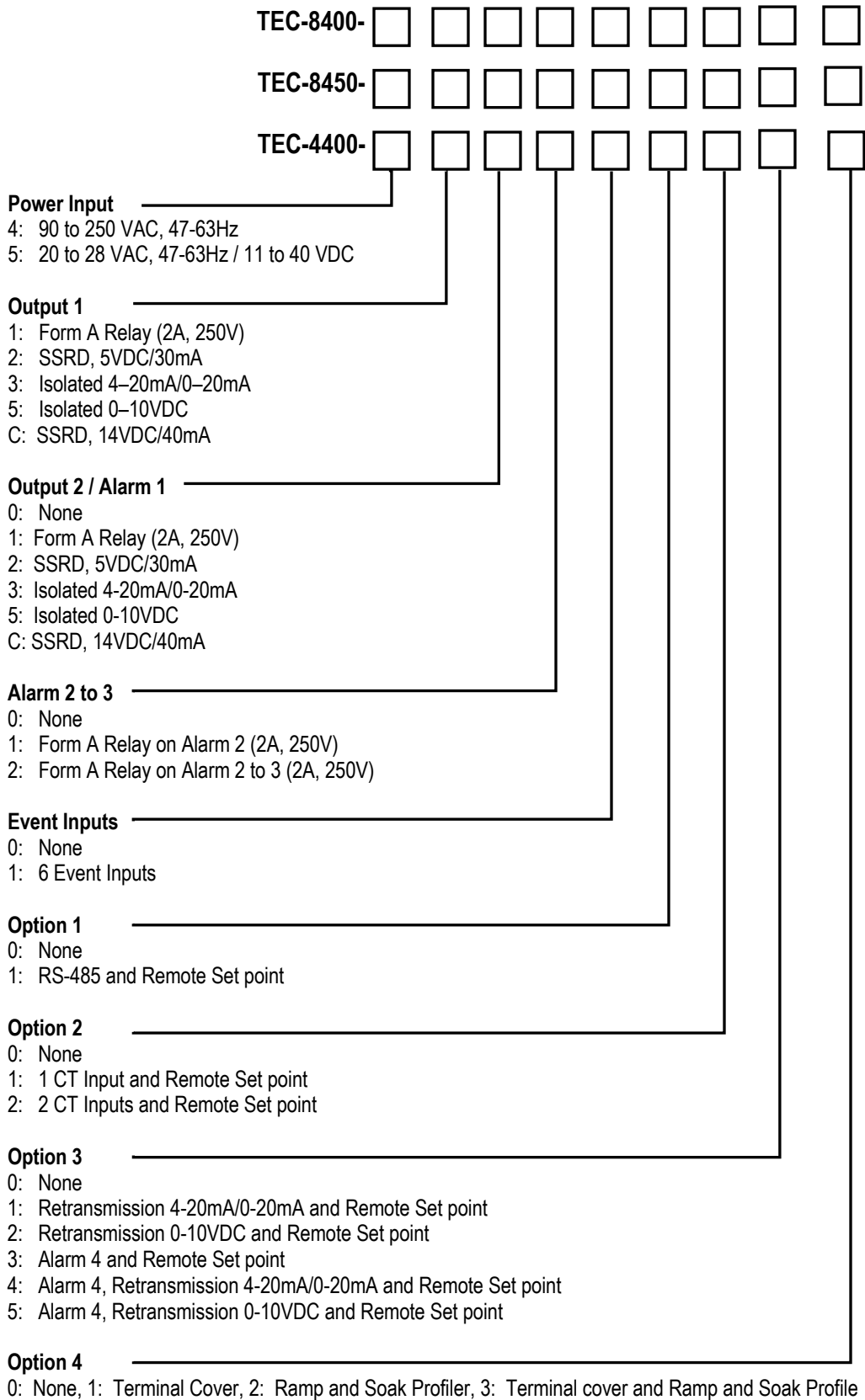

### 1.4.4 TEC-7400 Hardware code

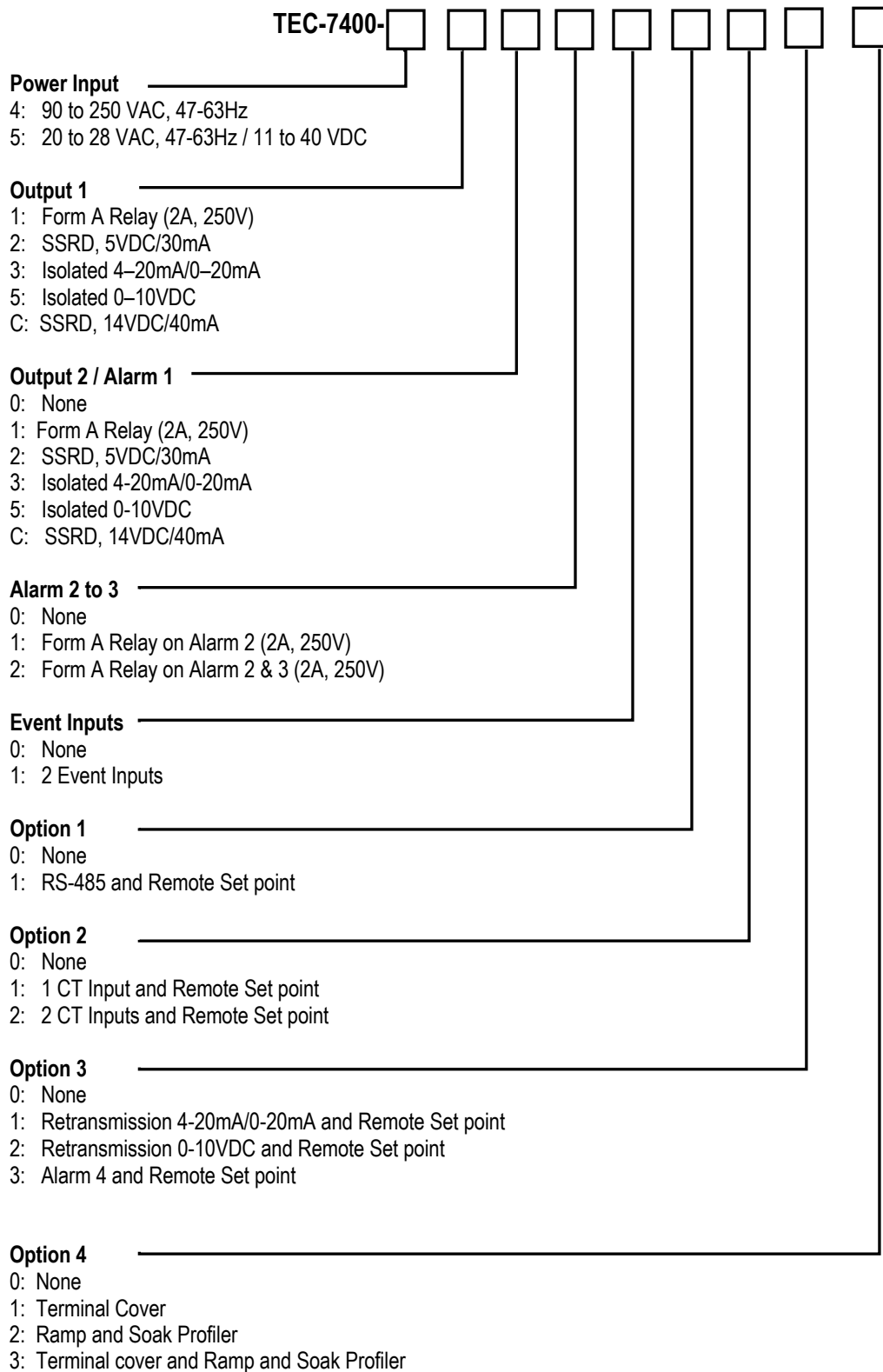

### 1.4.5 TEC-6400 Hardware code

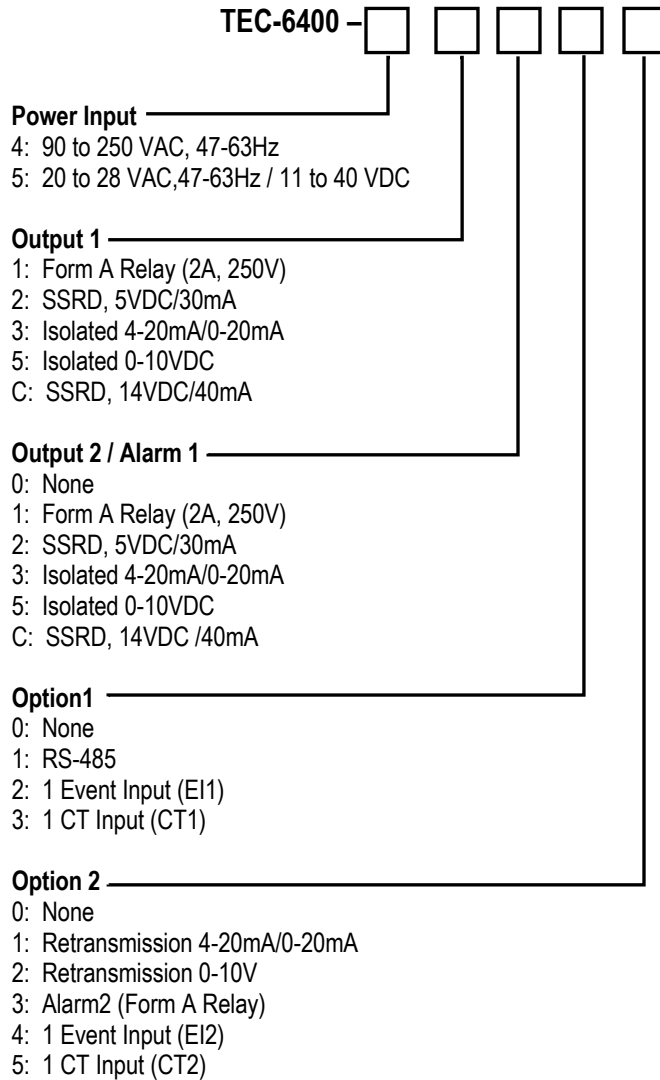

### 1.4.6 Accessories

- TEC-101-110 = 14VDC/40mA SSR Drive Module
- TEC-101-118 = Isolated 4-20mA/0-20mA Analog Output Module
- TEC-101-119 = Isolated 0-10VDC Analog Output Module
- TEC-102-122 = Isolated 4-20mA/0-20mA Retrans. Module for all models except TEC-2400 & TEC-6400
- TEC-102-123 = Isolated 0-10VDC Retransmission Module for all models except TEC-2400 & TEC-6400
- TEC99016 = USB Programming Adaptor
- TEC99015 = Programming Port Cable (1.5m)
- TEC99948 = Terminal Board

### 1.4.7 Related Products

TEC99003 = Smart Network Adaptor for third party software, which converts up to 255 channels of RS-485 or RS-422 to be usable on an RS-232 Network.

TEC99030 = Configuration Software: Available at [www.tempco.com](http://www.tempco.com)

## 1.5 Programming Port

A Micro USB Port provided on the controller can be used to connect to a PC by using a programming port cable (CC98-1) and a programming adapter (PA98-1) for firmware upgrades. \*The programming port is used for off-line automatic setup and testing procedures only. Do not attempt to make any connections to this port while the controller is being used during normal operation.\*

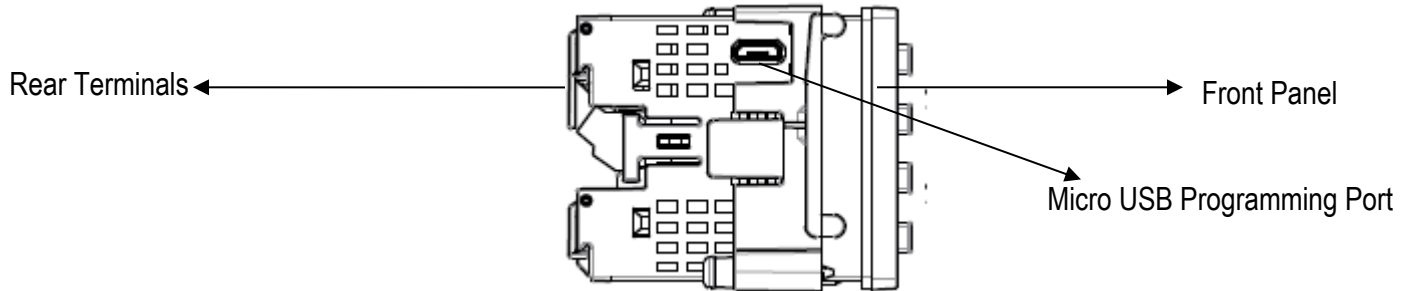

**1-3.Programming Port**

## 1.6 Keys and Displays

### KEYPAD OPERATION

**SCROLL KEY:** 

This key is used to select a parameter to be viewed or adjusted.

**UP KEY:** 

This key is used to increase the value of the selected parameter.

**DOWN KEY:** 



This key is used to decrease the value of the selected parameter.



**RESET KEY:** 



This key is used to:

1. Revert the display to the home screen.
2. Reset a latching alarm once the alarm condition is removed.
3. Stop manual control mode, Auto-Tuning mode or calibration mode.
4. Clear an Auto-Tuning or communication error message.
5. Restart the dwell timer when the dwell timer has timed out.
6. Enter the manual control menu if failure mode occurs.

### ENTER KEY:

Press  and hold for 5 seconds to enter the setup menu. The display will show .

Press and hold  for 6.2 seconds, then let go to enter manual mode. The display will show .

Press and hold  for 7.4 seconds, then let go to select Auto-Tuning. The display will show .

Press and hold  for 8.6 seconds, then let go to select calibration mode.

During power-up, the upper display will show PROG, and the lower display will show the Firmware version.

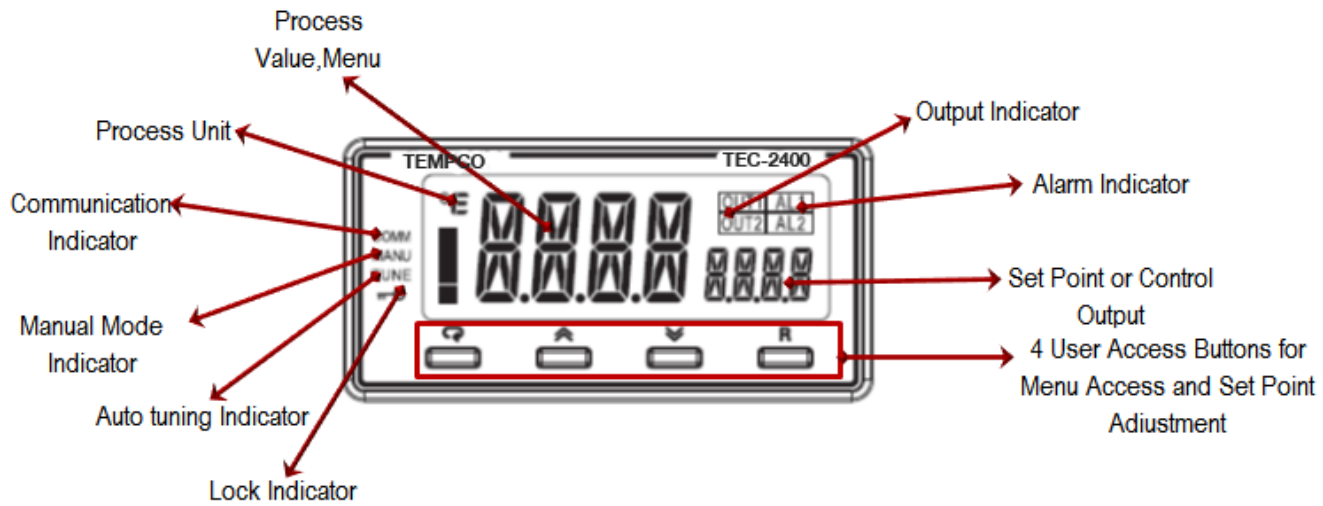

**1-4. TEC-2400 Front Panel Keys and Display**

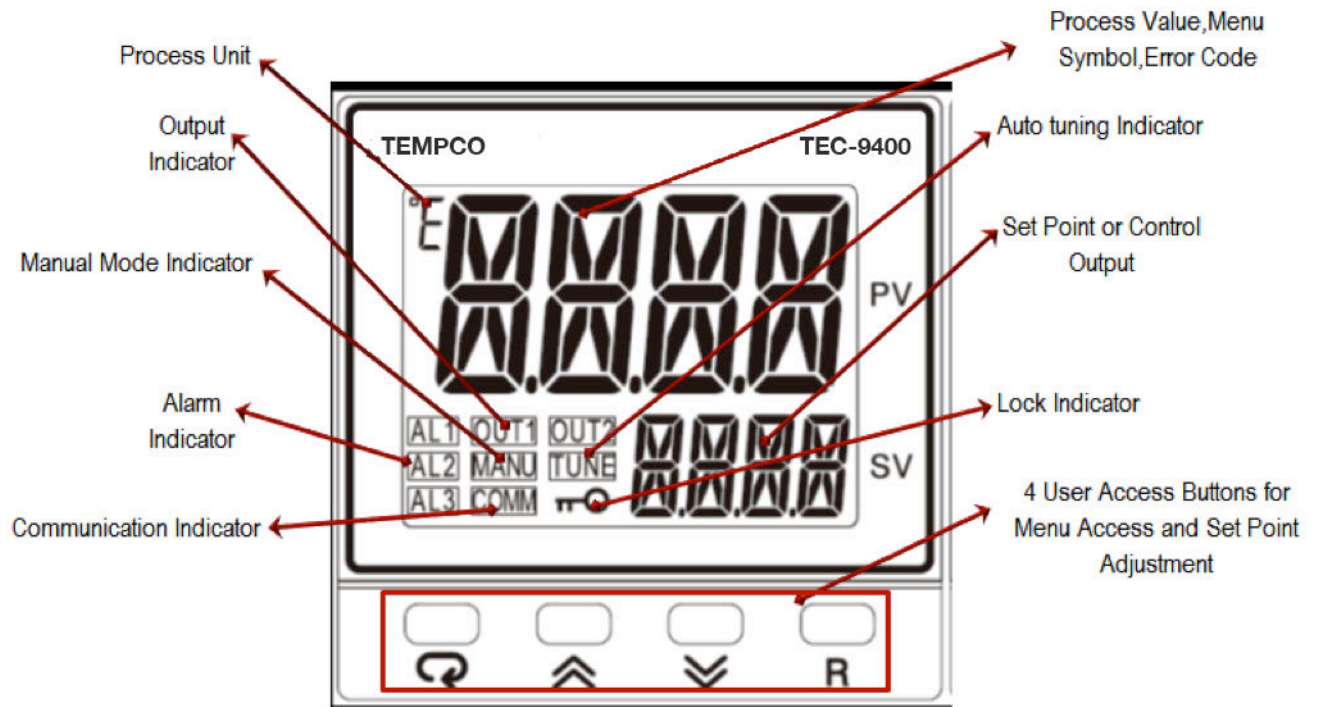

**1-5. TEC-9400 Front Panel Keys and Display**

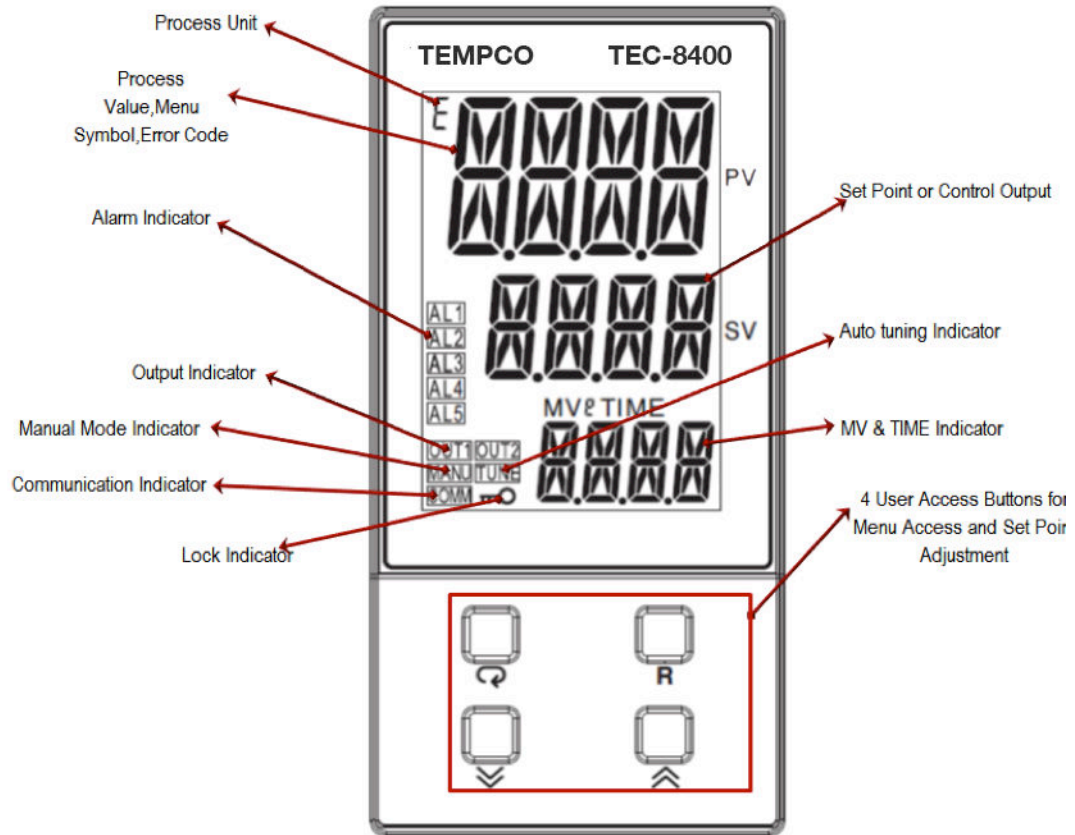

**1-6. TEC-8400 Front Panel Keys and Display**

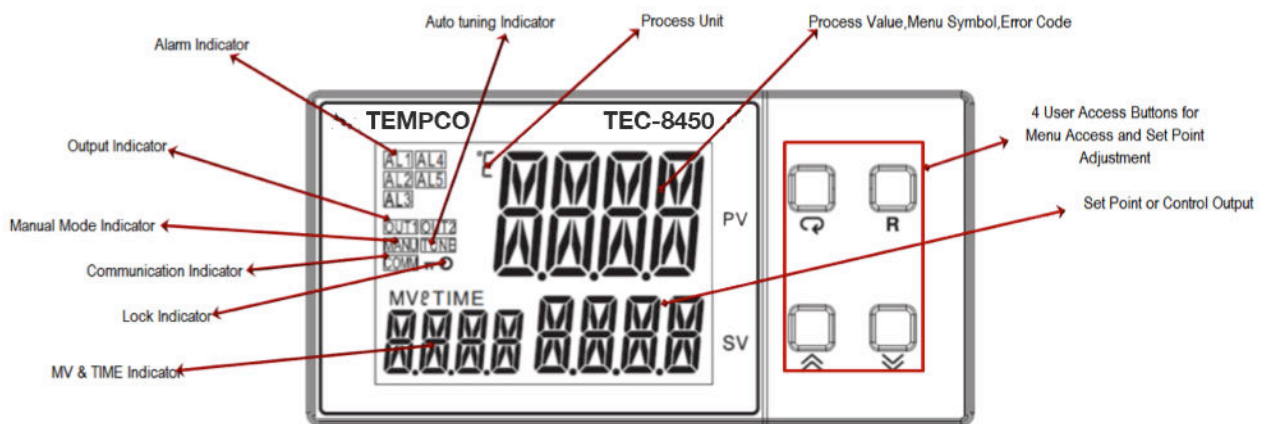

**1-7. TEC-8450 Front Panel Keys and Display**

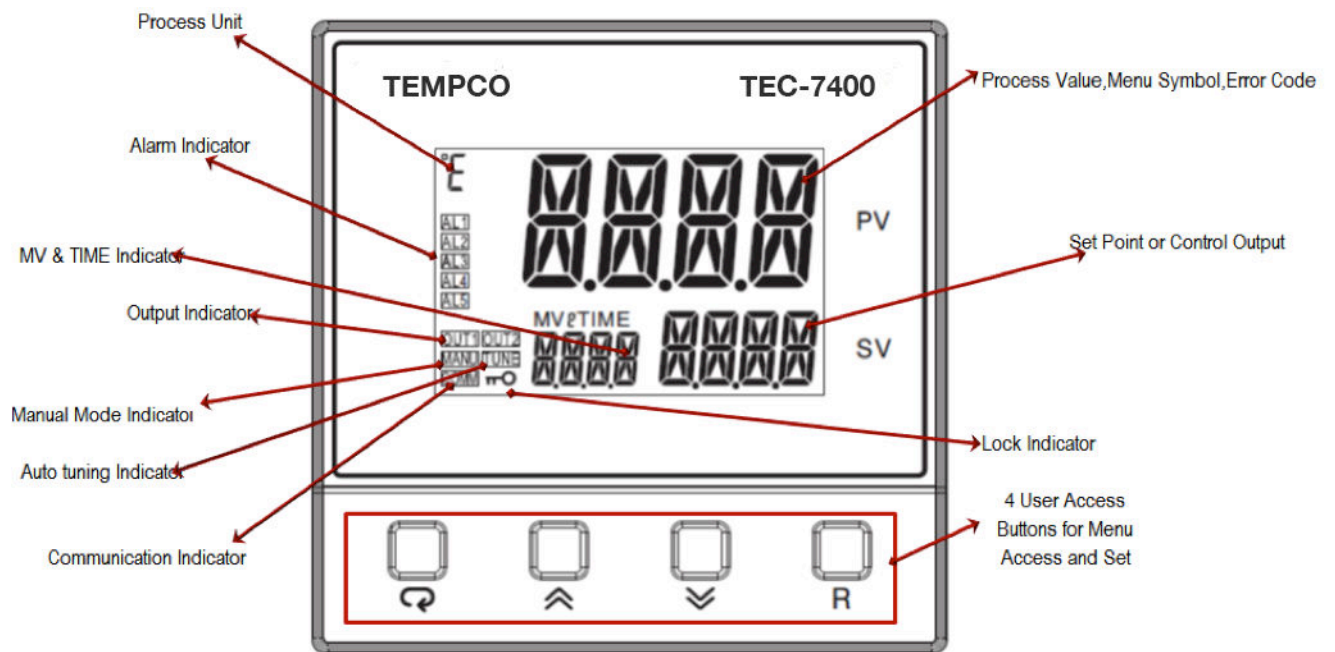

**1-8. TEC-7400 Front Panels Keys and Display**

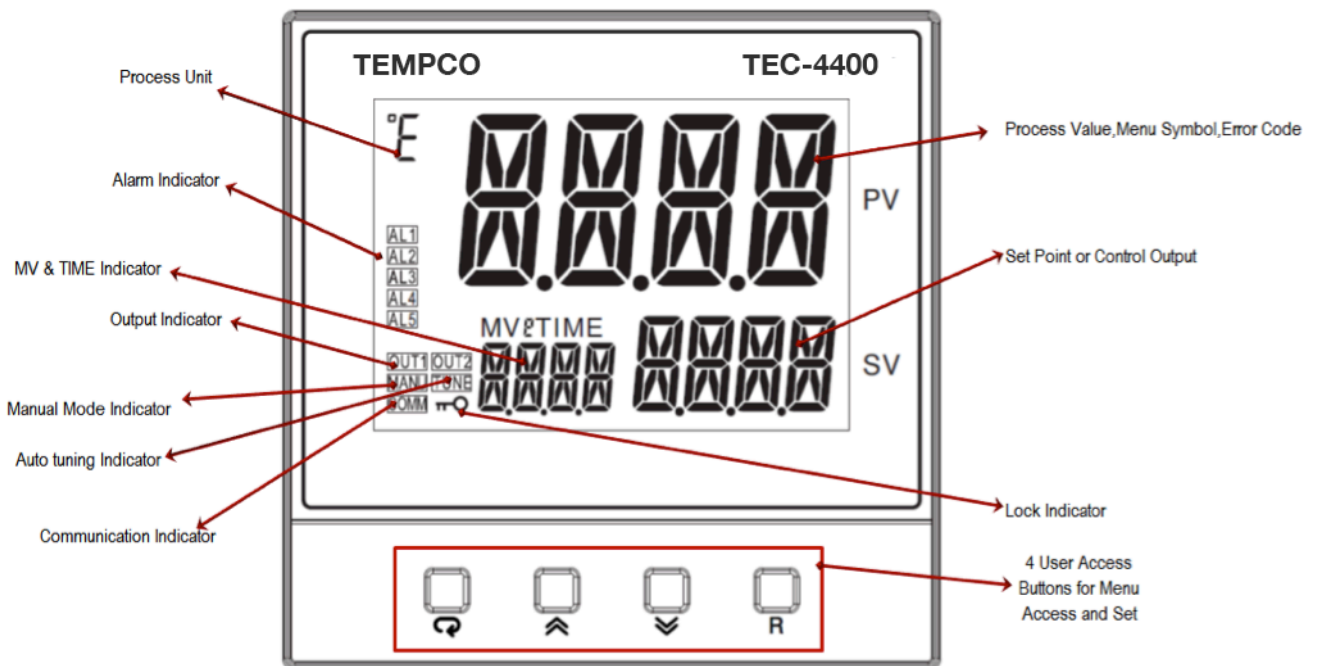

**1-9. TEC-4400 Front Panel Keys and Display**

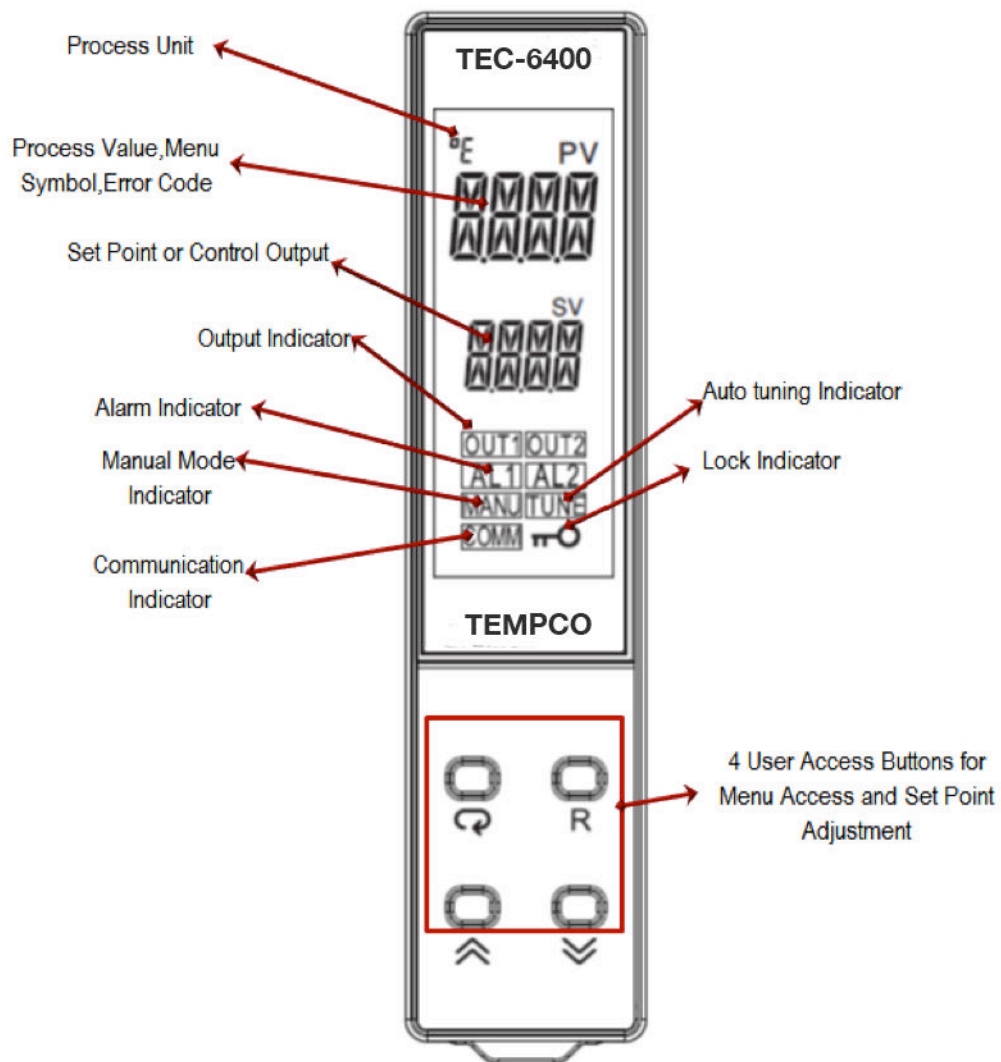

**1-10. TEC-6400 Front Panel Keys & Display**

A	B	C	D	E	F	G
H	I	J	K	L	M	N
O	P	Q	R	S	T	U
V	W	X	Y	Z		

**1-11. How Characters are Displayed on the LCD screen**

## 1.7 Menu Flowchart

The Menu has been divided in to 5 groups. They are as follows:

1. User Menu
2. Setup Menu
3. Manual Mode Menu
4. Auto-Tuning Mode Menu
5. Calibration Mode Menu

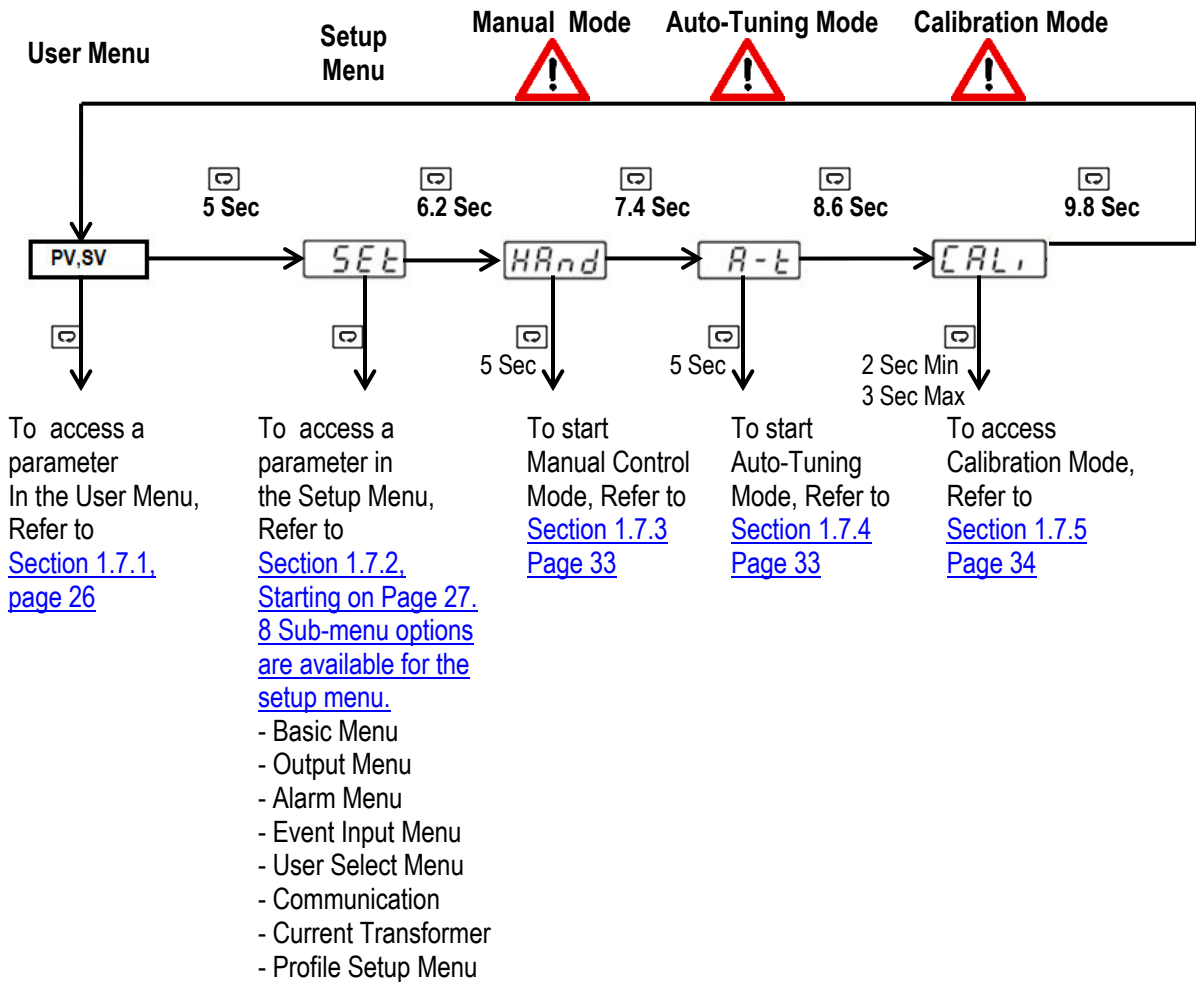

Press for the next parameter

Press and key to return to the previous parameter.

### 1.7.1 User Menu

The following user menu parameters are available depending on the current setup/configuration of the controller.

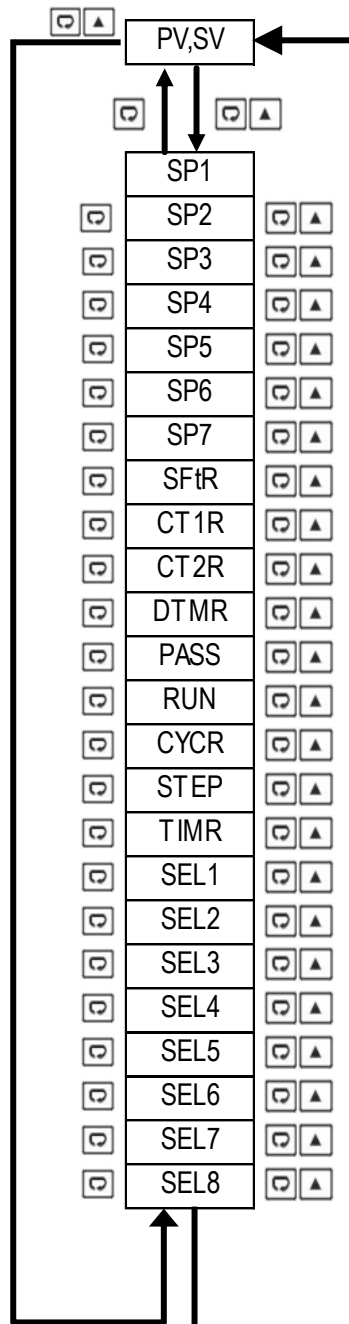



- See pgs. 44 & 88

## 1.7.2 Setup Menu

The setup menu has been categorized in to eight categories. They are listed below.

- |                              |  |
|------------------------------|--|
| 1. Basic Menu (pg 27.)       | 5. User Select Menu (pg. 30)             |
| 2. Output Menu (pg. 28)      | 6. Communication Menu (pg. 31)           |
| 3. Alarm Menu (pg. 29)       | 7. Current Transformer Menu (pg. 31)     |
| 4. Event Input Menu (pg. 30) | 8. Profile Menu (Ramp and Soak) (pg. 32) |

### 1.7.2.1 Basic Menu (bASE)

In the setup menu, when the upper display says “SET”, Use the  or  keys to get “bASE” in the lower display. Then, use the  key to cycle through the “bASE” menu parameters.

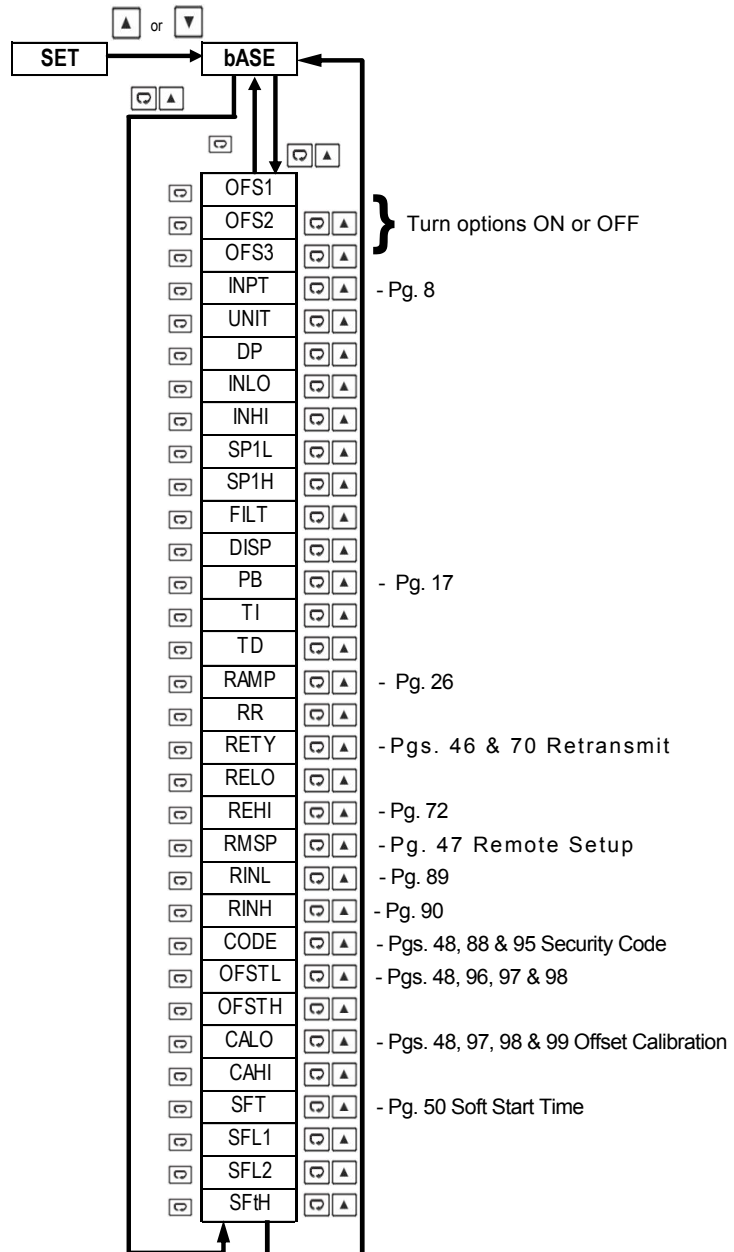

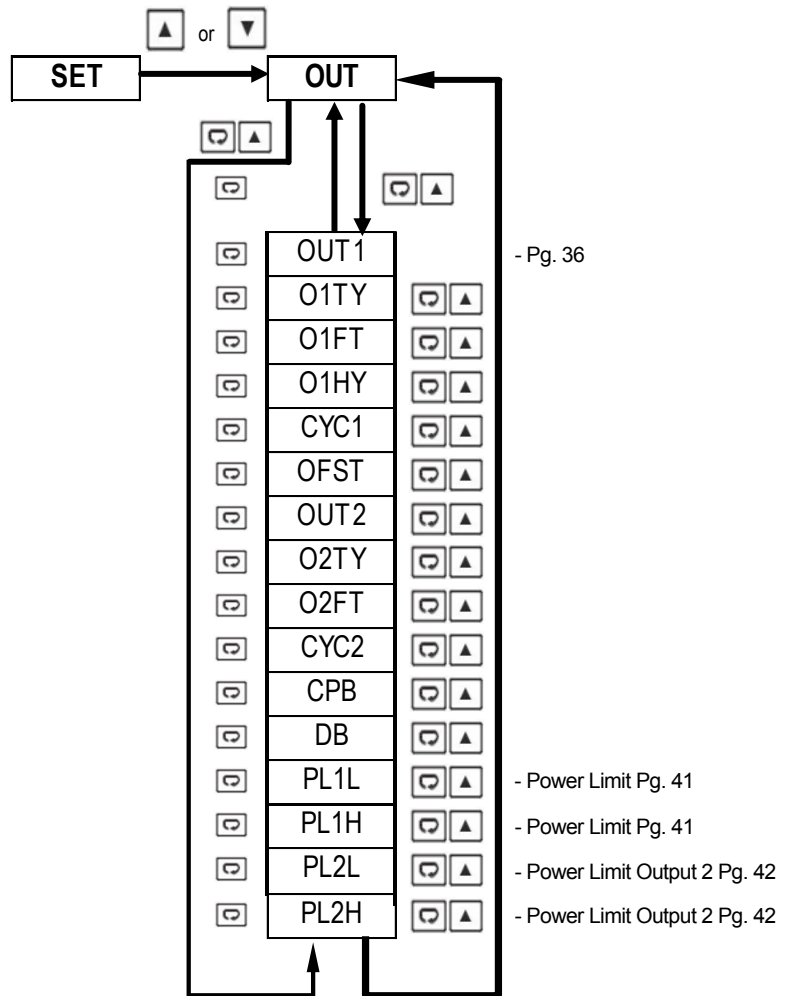

### 1.7.2.2 Output Menu (oUT)

In the setup menu, when the upper display says “SET”, use the ▲ or ▼ key to get “oUT” in the lower display. Then, use the ◀ key to cycle through the “oUT” menu parameters.



### 1.7.2.3 Alarm Menu (ALRM)

In the setup menu, when the upper display says “SET”, use the  or  key to get “ALRM” in the lower display. Then use the “” key to cycle through the “ALRM” menu parameters.

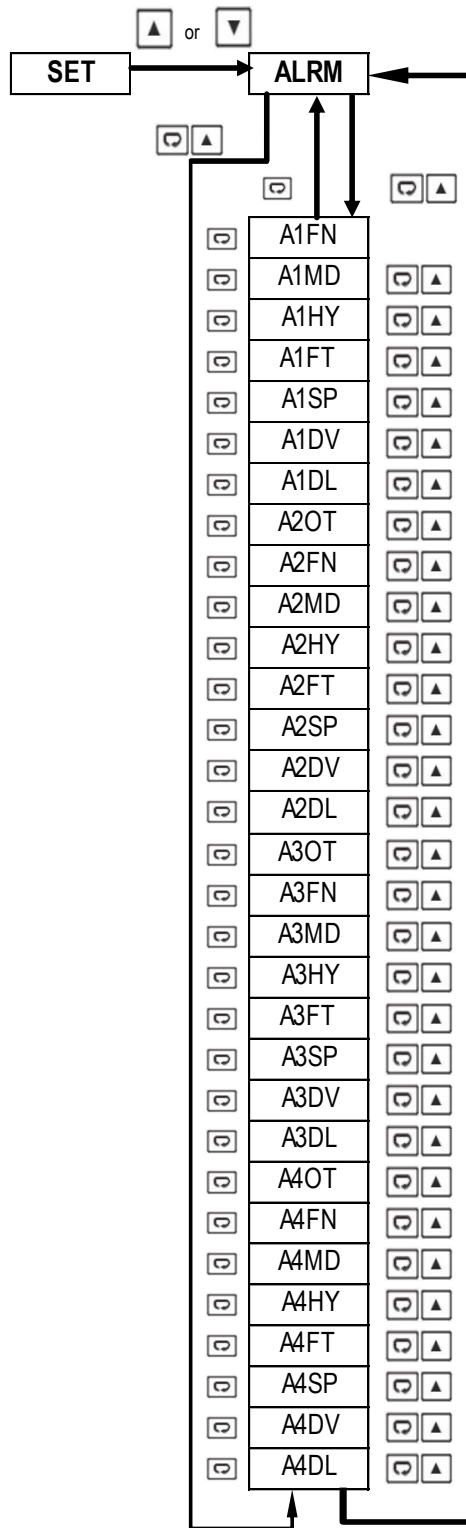

### 1.7.2.4 Event Input Menu (EI)

In the setup menu, when the upper display says “SET”, use the ▲ or ▼ key to get “EI” in the lower display. Then use the “☐” key to cycle through the “EI” (event input) menu parameters. (See Pg. 48)

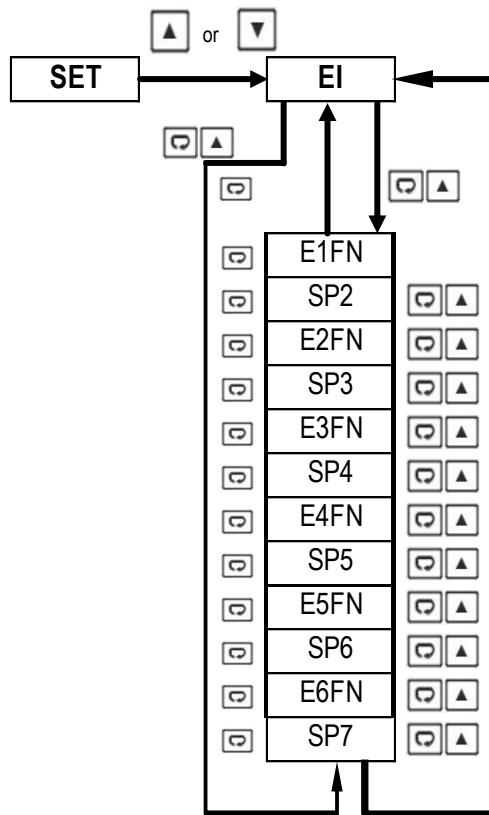

### 1.7.2.5 User Select Menu (SEL)

In the setup menu, when the upper display says “SET”, use the ▲ or ▼ key to get “SEL” in the lower display. Then, use the “☐” key to cycle through the “SEL” (select) user menu parameters. (See pg. 42)

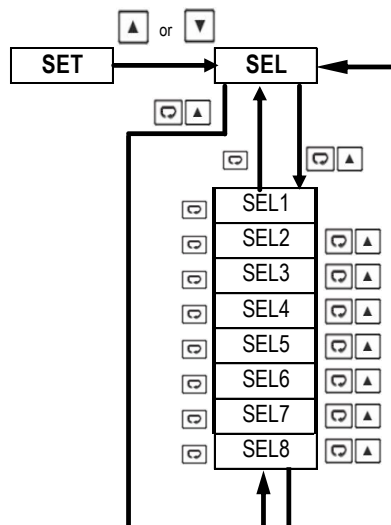



### 1.7.2.8 Profile Menu (PRoF) (Also referred to as “ramp and Soak”)

In the setup menu, when the upper display says “SET”, use the  $\uparrow$  or  $\downarrow$  keys to get “PRoF” in the lower display, then use the  $\square$  key to cycle through the “PRoF” (Ramp and Soak) menu parameters.

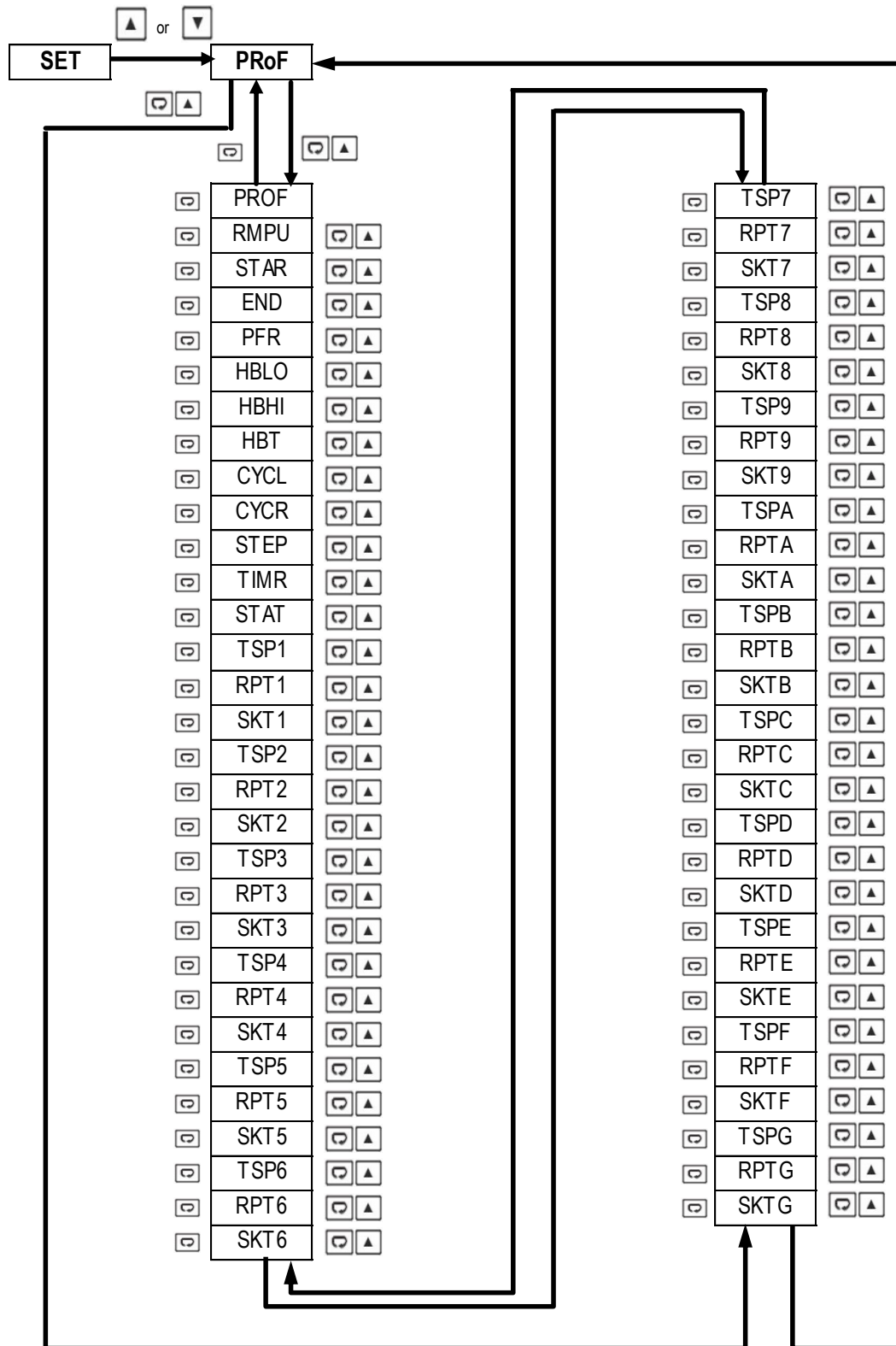

### 1.7.3 Manual Mode Menu

Press and hold the “☐” key for approx. 6sec until the “HAND” parameter is shown in the upper display. Then, press and hold the “☐” key for an additional 5 sec. until an “MANU” led starts to flash in the lower left of the display. Then, use the “☐” key to cycle through the available options.

User is able to manually set the out output to be energized from 0-100% of the cycle time.

“Hx.xx” is used to adjust output 1.

“Cx.xx” is used to adjust output 2.

You are able to exit manual mode by pressing and holding the **R** key.

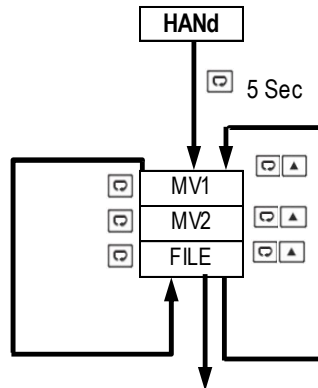

Press ☐ key 5 Sec To execute the selected default program

### 1.7.4 Auto-Tuning Mode

**A-t**

Press and hold the “☐” key for approx. 7sec until the “A-T” parameter is shown in the upper display.

Press and hold the “☐” key for 5 seconds to activate Auto-Tuning Mode. Continue to hold the “☐” key for an additional 3 seconds, else the display will revert to a “User Menu” parameter.

Auto-tuning allows the controller to find it’s own optimal control parameters (PID) by measuring the speed of your thermal process. **See page 99 for more information.**

### 1.7.5 Calibration Mode

Tempco strongly discourages attempting calibration unless absolutely necessary. The accuracy of the controller is very often more accurate than the sensor attached.

Changing calibration settings will void controller warranty.

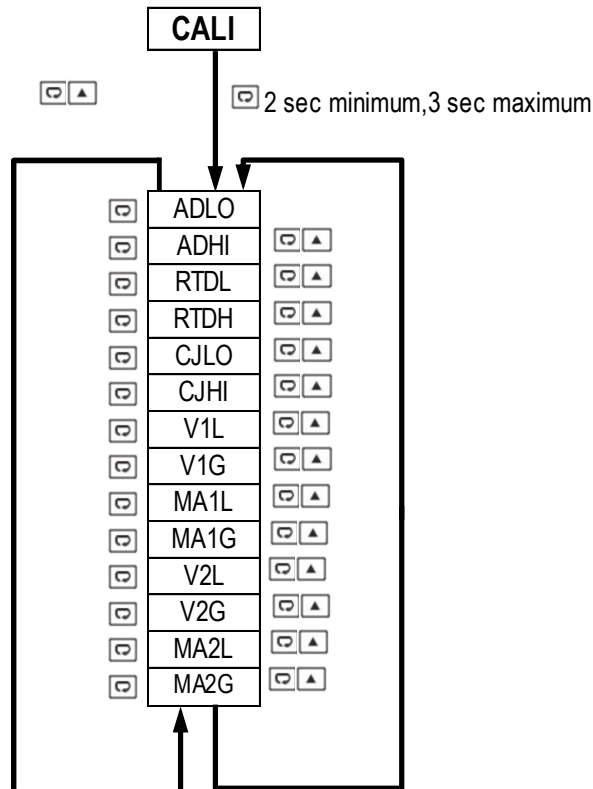

Press and hold the “” key for approx. 8sec until the “CAL” parameter is shown in the upper display.

Then, press and hold the “” key for 2 seconds or longer (not more than 3 seconds), then release it to enter calibration Mode.

Press and hold the “” Key for an additional 5 seconds to perform calibration.

**Note:**

- Using Manual, Auto-Tuning, Calibration modes will break the control loop and affect the output control while in the applicable mode.
- The flow chart shows a complete list of all parameters. For actual application, the number of available parameters will vary depending on the setup and model of controller, and will be less than that shown in the flow chart.

## 1.8 Parameter Description

Register Address	Parameter Notation	Parameter Description	Range	Default Value
0	SP1	Set Point 1 (Used for Output 1)	Low: SP1L High: SP1H	77.0°F (25 °C)
1	SP2	Set Point 2 (Used for output 2/Alarm 1)	Low: SP1L High: SP1H	212.0°F (100°C)
2	SP3	Set Point 3 (Used for Alarm 2)	Low: SP1L High: SP1H	212.0°F (100°C)
3	SP4	Set Point 4 (Used for alarm 3)	Low: SP1L High: SP1H	212.0°F (100°C)
4	SP5	Set Point 5 (Used for alarm 4)	Low: SP1L High: SP1H	212.0°F (100°C)
5	SP6	Set Point 6 (Used for alarm 5)	Low: SP1L High: SP1H	212.0°F (100°C)
6	SP7	Set Point 7 (Used for alarm 6)	Low: SP1L High: SP1H	212.0°F (100°C)
7	DTMR (pg. 97)	Dwell timer output time (Minute:Seconds)	Low: 0.0 High: 4553.5	0.0
8	INPT (pg. 88)	Input sensor selection	<b>0 J_tC:</b> J type Thermocouple <b>1 K_tC:</b> K type Thermocouple <b>2 T_tC:</b> T type Thermocouple <b>3 E_tC:</b> E type Thermocouple <b>4 B_tC:</b> B type Thermocouple <b>5 R_tC:</b> R type Thermocouple <b>6 S_tC:</b> S type Thermocouple <b>7 N_tC:</b> N type Thermocouple <b>8 L_tC:</b> L type Thermocouple <b>9 U_tC:</b> U type Thermocouple <b>10 P_tC:</b> P type Thermocouple <b>11 C_tC:</b> C type Thermocouple <b>12 D_tC:</b> D type Thermocouple <b>13 Pt.dN:</b> PT100 Ω DIN curve <b>14 Pt.JS:</b> PT100 Ω JIS curve <b>15 4-20:</b> 4-20mA linear current input <b>16 0-20:</b> 0-20mA linear current input <b>17 0-5V:</b> 0-5VDC linear voltage input <b>18 1-5V:</b> 1-5VDC linear voltage input <b>19 0-10:</b> 0-10VDC linear voltage input	0
9	UNIT (pg. 88)	Input unit selection	<b>0 oC:</b> °C unit <b>1 oF:</b> °F unit <b>2 Pu:</b> Process unit	1
10	DP (pg. 88)	Decimal point selection	<b>0 No.dP:</b> No decimal point <b>1 1-dP:</b> 1 decimal digit <b>2 2-dP:</b> 2 decimal digit <b>3 3-dP:</b> 3 decimal digit	0

Register Address	Parameter Notation	Parameter Description	Range	Default Value
11	INLO (pg. 88)	Input low scale value	Low: -19999 High: 45536	0.0°F (18.0°C)
12	INHI (pg. 88)	Input high scale value	Low: INLO+50 High: 45536	200.0° F (93.0° C)
13	SP1L (pg. 118)	Low limit of set point 1	Low: -19999 High :SP1H	0.0° F (18.0° C)
14	SP1H (pg. 118)	High limit of set point 1	Low: SP1L High: 45536	1000° F (538° C)
15	FILT (pg. 98)	Filter damping time constant of PV	<b>0 0:</b> 0 second time constant <b>1 0.2:</b> 0.2 second time constant <b>2 0.5:</b> 0.5 second time constant <b>3 1:</b> 1 second time constant <b>4 2:</b> 2 second time constant <b>5 5:</b> 5 second time constant <b>6 10:</b> 10 second time constant <b>7 20:</b> 20 second time constant <b>8 30:</b> 30 second time constant <b>9 60:</b> 60 second time constant	2
16	DISP	Secondary display selection (Setting not available on TEC2400/9400/6400)	<b>0 None:</b> No Display <b>1 MV1:</b> Display MV1 <b>2 MV2:</b> Display MV2 <b>3 tMR:</b> Display Dwell Time <b>4 PRoF:</b> display Profile Status	0
17	PB (pg. 101)	Proportional band value	Low: 0.0 High: 900.0°F (500.0°C)	104° F (40° C)
18	TI (pg. 101)	Integral time value	Low: 0 High: 3600 sec	60
19	TD (pg. 101)	Derivative time value	Low: 0.0 High: 360.0 sec	15
20	OUT1 (pg. 89)	Output 1 function	<b>0 REVR:</b> Reverse (heating) control action <b>1 dIRt :</b> Direct (cooling) control action	0

Basic Menu

Output Menu

Register Address	Parameter Notation	Parameter Description	Range	Default Value	
Output Menu	21	O1TY FACTORY SET, DO NOT CHANGE	Output 1 signal type	0 <b>RELY</b> : Relay output 1 <b>SSrd</b> : Solid state relay drive output 2 <b>4-20</b> : 4-20mA linear current 3 <b>0-20</b> : 0-20mA linear current 4 <b>0-5V</b> : 0-5VDC linear voltage 5 <b>1-5V</b> : 1-5VDC linear voltage 6 <b>0-10</b> : 0-10VDC linear voltage	Set per Hardware Code
	22	O1FT (pg. 99)	Output 1 failure transfer mode	Select BPLS (Bumpless transfer), or 0.0 ~ 100.0 % to continue output 1 control function if the sensor fails, or select OFF (0) or ON (1) for ON-OFF control	0
	23	O1HY (pg. 89)	Output 1 ON-OFF control hysteresis	Low: 0.1°C (0.2°F) High: 50.0°C (90.0°F)	0.2° F (0.1 °C)
	24	CYC1 (pg. 90)	Output 1 cycle time	Low: 0.1 High: 90.0 sec.	18 - Relay 1 - SSRD 0.0 Linear
	25	OFST (pg. 90)	Offset value for P control	Low: 0 High: 100.0 %	25
Base Menu	26	RAMP (pg. 96)	Ramp function selection	0 <b>NoNE</b> : No Ramp Function 1 <b>MINR</b> : Use %/minute as Ramp Rate 2 <b>HRR</b> : Use %/hour as Ramp Rate	0
	27	RR (pg. 96)	Ramp rate	Low: 0.0 High: 900.0°F	0
Output Menu	28	OUT2 (pg. 91)	Output 2 function	0 <b>NoNE</b> : Output2 turned off 1 <b>COOL</b> : Cooling PID Function 2 <b>AL1</b> : Alarm 1 Function 3 <b>rAL1</b> : Reverse Alarm 1 Function	2
	29	O2TY FACTORY SET, DO NOT CHANGE	Output 2 signal type	0 <b>RELY</b> : Relay output 1 <b>SSrd</b> : Solid state relay drive output 2 <b>4-20</b> : 4-20mA linear current 3 <b>0-20</b> : 0-20mA linear current 4 <b>0-5V</b> : 0-5VDC linear voltage 5 <b>1-5V</b> : 1-5VDC linear voltage 6 <b>0-10</b> : 0-10VDC linear voltage	Note top description 1 on

Register Address	Parameter Notation	Parameter Description	Range	Default Value
30	O2FT (pg. 99)	Output 2 failure transfer mode	Select BPLS (Bumpless transfer), or 0.0 ~ 100.0 % to continue output 2 control function if the sensor fails	0
31	CYC2 (pg. 102)	Output 2 cycle time	Low: 0.1 High: 90.0 sec.	18
32	CPB (pg. 90)	Cooling proportional band value	Low: 50 High: 300 %	100
33	DB (pg. 91)	Heating-cooling dead band (negative value= overlap)	Low: - 36.0 High: 36.0 %	0
34	A1FN (pg. 93)	Alarm 1 function for alarm 1 output	<ul style="list-style-type: none"> <li>0 <b>NoNE</b>: No alarm function</li> <li>1 <b>dtMR</b>: Dwell timer action</li> <li>2 <b>dE.HI</b>: Deviation high alarm</li> <li>3 <b>dE.Lo</b>: Deviation low alarm</li> <li>4 <b>db.HI</b>: Deviation band out of band alarm</li> <li>5 <b>db.Lo</b>: Deviation band in band alarm</li> <li>6 <b>PV.HI</b>: Process value high alarm</li> <li>7 <b>PV.Lo</b>: Process value low alarm</li> <li>8 <b>H.bK</b>: Heater break alarm</li> <li>9 <b>H.St</b>: Heater short alarm</li> </ul>	2
35	A1MD (pg. 94)	Alarm 1 operation mode	<ul style="list-style-type: none"> <li>0 <b>NoRM</b>: Normal alarm action</li> <li>1 <b>LtCH</b>: Latching alarm action</li> <li>2 <b>HoLd</b>: Hold alarm action</li> <li>3 <b>Lt.Ho</b>: Latching &amp; Hold action</li> <li>4 <b>SP.Ho</b>: Set point holding alarm</li> </ul>	0
36	A1HY (pg. 93)	Hysteresis control of alarm1	Low: 0.1°C High: 90.0°F(50.0°C)	0.2 °F (0.1 °C)

Output Menu

Alarm Menu

Alarm Menu

Register Address	Parameter Notation	Parameter Description	Range	Default Value
37	A1FT (pg. 95)	Alarm 1 failure transfer mode	<b>0 OFF:</b> Alarm output OFF if sensor fails <b>1 ON:</b> Alarm output ON if sensor fails	1
38	A1SP (pg. 93)	Alarm 1 set point	Low: -19999 High: 45536	212.0 °F (100.0°C)
39	A1DV (pg. 93)	Alarm 1 deviation value	Low: -19999 High: 45536	18.0 °F (10.0°C)
40	A2OT	Alarm 2 Output	<b>0 ALM:</b> Alarm 2 output 1 <b>1 RALM:</b> Reverse Alarm 2 Output	0
41	A2FN (pg. 93)	Alarm 2 function for alarm 2 output	<b>0 NoNE:</b> No alarm function <b>1 dtMR:</b> Dwell timer action <b>2 dE.HI:</b> Deviation high alarm <b>3 dE.Lo:</b> Deviation low alarm <b>4 db.HI:</b> Deviation band out of band alarm <b>5 db.Lo:</b> Deviation band in band alarm <b>6 PV.HI:</b> Process value high alarm <b>7 PV.Lo:</b> Process value low alarm <b>8 H.bK:</b> Heater break alarm <b>9 H.St:</b> Heater short alarm <b>10 E1.C.o:</b> Event Input 1 Control Alarm Output <b>11 E2.C.o:</b> Event Input 2 Control Alarm Output	2
42	A2MD (pg. 94)	Alarm 2 operation mode	<b>0 NoRM:</b> Normal alarm action <b>1 LtCH:</b> Latching alarm action <b>2 HoLd:</b> Hold alarm action <b>3 Lt.Ho:</b> Latching & Hold action <b>4 SP.Ho:</b> Set point holding alarm	0
43	A2HY (pg. 93)	Hysteresis control of alarm 2	Low: 0.1°C High: 90.0°F(50.0°C)	0.2° F (0.1° C)

Alarm Menu

Register Address	Parameter Notation	Parameter Description	Range	Default Value
44	A2FT (pg. 99)	Alarm 2 failure transfer mode	<b>0 OFF:</b> Alarm output OFF if sensor fails <b>1 ON:</b> Alarm output ON if sensor fails	1
45	A2SP	Alarm 2 set point	Low: -19999 High: 45536	212.0 °F (100.0°C)
46	A2DV	Alarm 2 deviation value	Low: -19999 High: 45536	18.0°F (10.0 °C)
47	A3OT	Alarm 3 output	<b>0 ALM:</b> Alarm 3 output <b>1 RALM:</b> Reverse Alarm3 Output	0
48	A3FN (pg. 93)	Alarm 3 function for alarm 3 output	<b>0 NoNE:</b> No alarm function <b>1 dtMR:</b> Dwell timer action <b>2 dE.HI:</b> Deviation high alarm <b>3 dE.Lo:</b> Deviation low alarm <b>4 db.HI:</b> Deviation band out of band alarm <b>5 db.Lo:</b> Deviation band in band alarm <b>6 PV.HI:</b> Process value high alarm <b>7 PV.Lo:</b> Process value low alarm <b>8 H.bK:</b> Heater break alarm <b>9 H.St:</b> Heater short alarm <b>10 E1.C.o:</b> Event Input 1 Control Alarm Output <b>11 E2.C.o:</b> Event Input 2 Control Alarm Output	2
49	A3MD (pg. 94)	Alarm 3 operation mode	<b>0 NoRM:</b> Normal alarm action <b>1 LtCH:</b> Latching alarm action <b>2 HoLd:</b> Hold alarm action <b>3 Lt.Ho:</b> Latching & Hold action <b>4 SP.Ho:</b> Set point holding alarm	0
50	A3HY (pg. 93)	Hysteresis control of alarm 3	Low: 0.1°C High: 90.0°F(50.0°C)	0.2°F (0.1°C)
51	A3FT (pg. 95)	Alarm 3 failure transfer mode	<b>0 OFF:</b> Alarm output OFF if sensor fails <b>1 ON:</b> Alarm output ON if sensor fails	1
52	A3SP	Alarm 3 set point	Low: -19999 High: 45536	212.0°F (100.0°C)
53	A3DV	Alarm 3 deviation value	Low: -19999 High: 45536	18.0°F (10.0°C)

Register Address	Parameter Notation	Parameter Description	Range	Default Value
54	A4OT	Alarm 4 output	0 <b>ALM</b> : Alarm 4 output 1 <b>RALM</b> : Reverse Alarm 4 Output	0
55	A4FN (pg. 93)	Alarm 4 function for alarm output	0 <b>NoNE</b> : No alarm function 1 <b>dtMR</b> : Dwell timer action 2 <b>dE.HI</b> : Deviation high alarm 3 <b>dE.Lo</b> : Deviation low alarm 4 <b>db.HI</b> : Deviation band out of band alarm 5 <b>db.Lo</b> : Deviation band in band alarm 6 <b>PV.HI</b> : Process value high alarm 7 <b>PV.Lo</b> : Process value low alarm 8 <b>H.bK</b> : Heater break alarm 9 <b>H.St</b> : Heater short alarm	2
56	A4MD (pg. 94)	Alarm 4 operation mode	0 <b>NoRM</b> : Normal alarm action 1 <b>LtCH</b> : Latching alarm action 2 <b>HoLd</b> : Hold alarm action 3 <b>Lt.Ho</b> : Latching & Hold action 4 <b>SP.Ho</b> : Set point holding alarm	0
57	A4HY (pg. 93)	Hysteresis control of alarm 4	Low: 0.1°C High: 90.0°F(50.0°C)	0.2°F (0.1°C)
58	A4FT (pg. 95)	Alarm 4 failure transfer mode	0 <b>OFF</b> : Alarm output OFF if sensor fails 1 <b>ON</b> : Alarm output ON if sensor fails	1
59	A4SP	Alarm 4 set point	Low: -19999 High: 45536	212.0°F (100.0°C)
60	A4DV	Alarm 4 deviation value	Low: -19999 High: 45536	18.0 °F (10.0 °C)
61	PL1L	Output 1 Low Power limit	Low: 0 High:PL1H or 50%	0
62	PL1H	Output 1 High Power limit	Low: PL1L High: 100 %	100

Alarm Menu

Output Menu

	Register Address	Parameter Notation	Parameter Description	Range	Default Value
Output Menu	63	PL2L	Output 2 Low Power limit	Low: 0 High: PL2H or 50%	0
	64	PL2H	Output 2 Low Power limit	Low: PL2L High: 100 %	100
User Select Menu	65	SEL1-8 (pg. 95)	Select parameter for user menu	<b>NoNE</b> <b>dtMR</b> : DTMR is moved to USER Menu <b>dISP</b> : DISP is moved to USER Menu <b>Pb</b> : PB is moved to USER Menu <b>tI</b> : TI is moved to USER Menu <b>td</b> : TD is moved to USER Menu <b>o1HY</b> : O1HY is moved to USER Menu <b>RR</b> : RR is moved to USER Menu <b>CPb</b> : CPB is moved to USER Menu <b>db</b> : DB is moved to USER Menu <b>A1HY</b> : A1HY is moved to USER Menu <b>A1SP</b> : A1SP is moved to USER Menu <b>A1dV</b> :A1DV is moved to USER Menu <b>A2HY</b> : A2HY is moved to USER Menu <b>A2SP</b> : A2SP is moved to USER Menu <b>A2dV</b> :A2DV is moved to USER Menu <b>A3HY</b> : A3HY is moved to USER Menu <b>A3SP</b> : A3SP is moved to USER Menu <b>A3dV</b> :A3DV is moved to USER Menu <b>A4HY</b> : A4HY is moved to USER Menu <b>A4SP</b> : A4SP is moved to USER Menu <b>A4dV</b> :A4DV is moved to USER Menu	None

↑  
User  
Select  
Menu  
↓

Register Address	Parameter Notation	Parameter Description	Range	Default Value
66	SEL1-8 (pg. 95)	Select parameter for user menu	<p><b>L1L:</b>PL1L is moved to USER Menu  <b>PL1H:</b>PL1H is moved to USER Menu  <b>PL2L:</b> PL2L is moved to USER Menu  <b>PL2H:</b>PL2H is moved to USER Menu  <b>OFTL:</b>OFTL is moved to USER Menu  <b>OFTH:</b>OFTH is moved to USER Menu  <b>CALO:</b>CALO is moved to USER Menu  <b>CAHI:</b>CAHI is moved to USER Menu  <b>A1DL:</b> A1DL is moved to USER Menu  <b>A2DL:</b> A2DL is moved to USER Menu  <b>A3DL:</b> A3DL is moved to USER Menu  <b>A4DL:</b> A4DL is moved to USER Menu</p>	None
67	OFS11  FACTORY SET, DO NOT CHANGE	Option function 1 selection	<p><b><u>TEC-8400/TEC-8450/TEC-7400/TEC-4400:</u></b></p> <p>0 <b>NoNE:</b> Not selected  1 <b>R485:</b> RS-485 and Remote SP</p> <hr/> <p><b><u>TEC-9400:</u></b></p> <p>0 <b>NoNE:</b> Not selected  1 <b>R485:</b> RS-485</p> <hr/> <p><b><u>TEC-2400/TEC-6400:</u></b></p> <p>0 <b>NoNE:</b> Not selected  1 <b>R485:</b> RS-485  2 <b>E11:</b> Event 1 input  3 <b>CT1:</b> CT 1 input  4 <b>4-20:</b> 4-20mA retransmission output  5 <b>0-20:</b> 0-20mA retransmission output  6 <b>0-5V:</b> 0-5VDC retransmission output  7 <b>1-5V:</b> 1-5VDC retransmission output  8 <b>0-10:</b> 0-10VDC retransmission output</p>	None

Register Address	Parameter Notation	Parameter Description	Range	Default Value
68	OFS2  FACTORY SET, DO NOT CHANGE	Option function 2 selection	<p><b><u>TEC-8400/TEC-8450/TEC-7400/TEC-4400:</u></b>   <b>NoNE:</b> Not selected  <b>CT1:</b> CT1 input and Remote SP  <b>CT1.2:</b> CT1,CT2 inputs and Remote SP</p> <hr/> <p><b><u>TEC-9400:</u></b>   <b>NoNE:</b> Not selected  <b>EI1.2:</b> Event input 1 &amp; Event input 2  <b>EI.CT:</b> Event input 1 &amp; CT2 input  <b>CT1.2:</b> CT1 and CT2 inputs</p> <hr/> <p><b><u>TEC-2400:</u></b>   <b>NoNE:</b> No selected  <b>4-20:</b> 4-20mA retransmission output  <b>0-20:</b> 0-20mA retransmission output  <b>0-5V:</b> 0-5V retransmission output  <b>1-5V:</b> 1-5V retransmission output  <b>0-10:</b> 0-10 retransmission output  <b>AL2:</b> Alarm 2 output</p> <hr/> <p><b><u>TEC-6400:</u></b>   <b>NoNE:</b> No selected  <b>4-20:</b> 4-20mA retransmission output  <b>0-20:</b> 0-20mA retransmission output  <b>0-5V:</b> 0-5V retransmission output  <b>1-5V:</b> 1-5V retransmission output  <b>0-10:</b> 0-10 retransmission output  <b>AL2:</b> Alarm 2 output  <b>EI2:</b> Event2 Input  <b>CT2:</b>CT2 Input</p>	None

Register Address	Parameter Notation	Parameter Description	Range	Default Value
69	OFS3  FACTORY SET, DO NOT CHANGE	Option function 3 selection	<p><b><u>TEC-8400/TEC-8450/TEC-4400:</u></b></p> <p><b>NoNE:</b> Not selected  <b>4-20:</b> 4-20mA retransmission output and Remote SP  <b>0-20:</b> 0-20mA retransmission output and Remote SP  <b>0-5V:</b> 0-5VDC retransmission output and Remote SP  <b>1-5V:</b> 1-5VDC retransmission output and Remote SP  <b>0-10:</b> 0-10VDC retransmission output and Remote SP  <b>A.4.20:</b> Alarm 4, 4-20mA retransmission output and Remote SP  <b>A.0.20:</b> Alarm 4, 0-20mA retransmission output and Remote SP  <b>A.0.5V:</b> Alarm 4,0-5V retransmission output and Remote SP  <b>A.1.5V:</b> Alarm 4,1-5V retransmission output and Remote SP  <b>A.0.10:</b> Alarm 4, 0-10V retransmission output and Remote SP</p> <hr/> <p><b><u>TEC-7400:</u></b></p> <p><b>NoNE:</b> Not selected  <b>4-20:</b> 4-20mA retransmission output and Remote SP  <b>0-20:</b> 0-20mA retransmission output and Remote SP  <b>0-5V:</b> 0-5VDC retransmission output and Remote SP  <b>1-5V:</b> 1-5VDC retransmission output and Remote SP  <b>0-10V:</b> 0-10VDC retransmission output and Remote SP  <b>AL4:</b>Alarm 4 Output</p> <hr/> <p><b><u>TEC-9400:</u></b></p> <p><b>NoNE:</b> Not selected  <b>4-20:</b> 4-20mA retransmission output  <b>0-20:</b> 0-20mA retransmission output  <b>0-5V:</b> 0-5VDC retransmission output  <b>1-5V:</b> 1-5VDC retransmission output  <b>0-10:</b> 0-10VDC retransmission output  <b>AL3:</b> Alarm 3 output</p>	None

	Register Address	Parameter Notation	Parameter Description	Range	Default Value
Basic Menu	70	RETY (pg. 103)	Retransmission type	<b>0</b> <i>RE.PV</i> : Retransmit process value <b>1</b> <i>RE.SP</i> : Retransmit set point value	0
	71	RELO (pg. 103)	Retransmission low scale value	Low: -19999 High: 45536	-----
	72	REHI (pg. 103)	Retransmission high scale value	Low: -19999 High: 45536	-----
Comm. Menu	73	ADDR (pg. 102)	Address assignment of digital communication	Low: 1 High: 255	1
	74	BAUD (pg. 102)	Baud rate of digital communication	<b>2K4</b> : 2.4 Kbits/s baud rate <b>4K8</b> : 4.8 Kbits/s baud rate <b>9K6</b> : 9.6 Kbits/s baud rate <b>14K4</b> : 14.4 Kbits/s baud rate <b>19K2</b> : 19.2 Kbits/s baud rate <b>28K8</b> : 28.8 Kbits/s baud rate <b>38K4</b> : 38.4 Kbits/s baud rate <b>57K6</b> : 57.6 Kbits/s baud rate <b>115K</b> : 115.2 Kbits/s baud rate	<b>2K4</b>
	75	DATA (pg. 102)	Data bit count of digital communication	<b>7blt</b> : 7 data bits <b>8blt</b> : 8 data bits	<b>7blt</b>
	76	PARI (pg. 102)	Parity bit of digital communication	<b>EVEN</b> : Even parity <b>Odd</b> : Odd parity <b>NoNE</b> : No parity bit	<b>EVEN</b>
	77	STOP (pg. 102)	Stop bit count of digital communication	<b>1blt</b> : One stop bit <b>2blt</b> : Two stop bits	0
	78	CT1R (pg. 103)	Reading of CT 1	Low: 0.0 High: 150.0	0.0
	79	CT2R (pg. 103)	Reading of CT 2	Low: 0.0 High: 150.0	0.0
Current Transfer Input Menu	80	HBEN (pg. 103)	Enable Heater break detection	<b>oFF</b> : Off <b>oN</b> : On	0
	81	HBHY (pg. 103)	Heater break hysteresis	Low: 0.1 High: 50.0	0.1

	Register Address	Parameter Notation	Parameter Description	Range	Default Value
Current Transfer Input Menu	82	HB1T (pg. 103)	Trip point current for heater break 1	Low: 0.0 High: 120.0	0.0
	83	HB2T (pg. 103)	Trip point current for heater break 2	Low: 0.0 High: 120.0	0.0
	84	HSEN (pg. 103)	Enable Heater short detection	<b>oFF:</b> Off <b>oN:</b> On	<b>oFF</b>
	85	HSHY (pg. 103)	Heater short hysteresis	Low: 0.1 High: 50.0	0.1
	86	HS1T (pg. 103)	Trip point current for heater short 1	Low: 0.0 High: 120.0	<b>50.0</b>
	87	HS2T (pg. 103)	Trip point current for heater short 2	Low: 0.0 High: 120.0	<b>50.0</b>
Basic Menu	88	RMSP (pg. 105)	Remote SP type	<b>None:</b> No Remote SP <b>4-20:</b> 4-20mA retransmission output <b>0-20:</b> 0-20mA retransmission output <b>0-5V:</b> 0-5VDC retransmission output <b>1-5V:</b> 1-5VDC retransmission output <b>0-10:</b> 0-10VDC retransmission output	None
	89	RINL (pg. 105)	Remote SP Input low scale value	Low: -19999 High: RINH-50	0.0°F
	90	RINH (pg. 105)	Remote SP Input high scale value	Low: RINL+50 High: 45536	200.0°F
Indication Only	91	FILE (pg. 102)	Default File Selection	<b>dFLt:</b> Default Menu <b>Ld.Us:</b> Load User Setting <b>St.Us:</b> Store User Setting	0
	92	MV1	Output 1 percentage value (Heating )	Low: 0.00 High: 100.00	-----

	Register Address	Parameter Notation	Parameter Description	Range	Default Value
Indication Only	93	MV2	Output 2 percentage value (Cooling )	Low: 0.00 High: 100.00	-----
User Menu	94	PASS (pg. 88)	Password entry	Low: 0 High: 9999	0
Basic Menu	95	CODE (pg. 88)	Security code for parameter protection	Low: 0 High: 9999 0 = unprotected 1000 = user mode unprotected 9999 = SPx(1 to 7) unprotected	0
	96	OFTL (pg. 97)	Offset value for low point calibration	Low: -1999 High: 1999	0
	97	OFTH (pg. 97)	Offset value for high point calibration	Low: -1999 High: 1999	0
	98	CALO (pg. 97)	Input signal value during low point calibration	Low: -19999 High: CAHI-1	0
	99	CAHI (pg. 97)	Input signal value during high point calibration	Low: CALO+1 High: 45536	1000
Event Input Menu	100	E1FN (pg. 104)	Event input 1 function	<b>0 NoNE:</b> none <b>1 SP2:</b> SP2 activated to replace SP1 <b>2 rS.A1:</b> Reset alarm 1 output <b>3 rS.A2:</b> Reset alarm 2 output <b>4 rS.A3:</b> Reset alarm 3 output <b>5 rS.A4:</b> Reset alarm 4 output <b>6 rS.Ao:</b> Reset all alarm outputs <b>7 CA.LH:</b> Cancel alarm latch <b>8 d.o1:</b> Disable output 1 <b>9 d.o2:</b> Disable output 2 <b>10 d.o12:</b> Disable output 1 and 2 <b>11 LoCK:</b> Lock all parameters and Read only communication <b>12 AU.MA:</b> Switch Auto and Manual control mode <b>13 F.trA:</b> Failure Transfer <b>14 AL.oN:</b> EI Control Alarm Output	<b>NoNE</b>
	101	E2FN (pg. 104)	Event input 2 function	<b>SP3:</b> SP3 activated to replace SP1 <b>Others:</b> Same as E1FN	<b>NoNE</b>

Register Address	Parameter Notation	Parameter Description	Range	Default Value
102	E3FN (pg. 104)	Event input 3 function	<b>0 NoNE:</b> none <b>1 SP4:</b> SP4 activated to replace SP1 <b>2 rS.A1:</b> Reset alarm 1 output <b>3 rS.A2:</b> Reset alarm 2 output <b>4 rS.A3:</b> Reset alarm 3 output <b>5 rS.A4:</b> Reset alarm 4 output <b>6 rS.Ao:</b> Reset all alarm outputs <b>7 CA.LH:</b> Cancel alarm latch <b>8 d.o1:</b> Disable output 1 <b>9 d.o2:</b> Disable output 2 <b>10 d.o12:</b> Disable output 1 and 2 <b>11 LoCK:</b> Lock all parameters and Read only communication <b>12 AU.MA:</b> Switch Auto and Manual control mode <b>13 F.tr:</b> Failure Transfer <b>15 StAR:</b> Run profile as RUN=STAR <b>16 CoNt:</b> Run Profile as RUN=CONT <b>17 PV:</b> Run Profile as RUN=PV <b>18 HoLd:</b> Run Profile as RUN=HOLD <b>19 StoP:</b> Run Profile as RUN=STOP	<b>NoNE</b>
103	E4FN (pg. 104)	Event input 4 function	<b>SP5:</b> SP5 activated to replace SP1 <b>Others:</b> Same as E3FN	<b>NoNE</b>
104	E5FN (pg. 104)	Event input 5 function	<b>NoNE:</b> none <b>SP4:</b> SP4 activated to replace SP1 <b>rS.A1:</b> Reset alarm 1 output <b>rS.A2:</b> Reset alarm 2 output <b>rS.A3:</b> Reset alarm 3 output <b>rS.A4:</b> Reset alarm 4 output <b>rS.Ao:</b> Reset all alarm outputs <b>CA.LH:</b> Cancel alarm latch <b>d.o1:</b> Disable output 1 <b>d.o2:</b> Disable output 2 <b>d.o12:</b> Disable output 1 and 2 <b>LoCK:</b> Lock all parameters and Read only communication <b>AU.MA:</b> Switch Auto and Manual control mode <b>F.tr:</b> Failure Transfer	<b>NoNE</b>
105	E6FN (pg. 104)	Event input 6 function	<b>SP7:</b> SP7 activated to replace SP1 <b>Others:</b> Same as E5FN	<b>NoNE</b>
106	A1DL (pg. 95)	Alarm 1 Delay (Minutes: Seconds)	Low: 00.00 (OFF) High: 99.59	00.00
107	A2DL (pg. 95)	Alarm 2 Delay (Minutes: Seconds)	Low: 00.00(OFF) High: 99.59	00.00
108	A3DL (pg. 95)	Alarm 3 Delay (Minutes: Seconds)	Low: 00.00(OFF) High: 99.59	00.00

Event Input Menu

Alarm Menu

	Register Address	Parameter Notation	Parameter Description	Range	Default Value
Alarm Menu	109	A4DL (pg. 95)	Alarm 4 Delay (Minutes: Seconds)	Low: 00.00(OFF) High:99.59	00.00
	110	SFT (pg. 92)	Soft Start Time (Hours: Minutes)	Low: 00.00(OFF) High:99.59	00.00
Basic Menu	111	SFL1 (pg. 92)	Soft Start Power Limit for Output 1	Low: PL1L High:PL1H	0
	112	SFL2 (pg. 92)	Soft Start Power Limit for Output 2	Low: PL2L High:PL2H	0
	113	SFTH (pg. 92)	Soft Start Threshold	Low: -19999 High:45536	212.0 °F
	114	SFTR	Soft Start Timer (Hours: Minutes)	Low: 00.00 High:99.59	00.00
ALL RAMP AND SOAK PROGRAMMING INFORMATION BEGINS ON PAGE 105					
Profile Menu	115	PROF	Profile selection	<b>None:</b> Not used. <b>1--4:</b> Uses steps 1 to 4 <b>5--8:</b> Uses steps 5 to 8 <b>1--8:</b> Uses steps 1 to 8 <b>9-12:</b> Uses steps 9 to 12 <b>1316:</b> Uses steps 13 to 16 <b>9-16:</b> Uses steps 9 to 16 <b>1-16:</b> Uses steps 1 to 16	<b>NoNE</b>
	116	RUN	Profile run control	<b>StAR:</b> Start to run profile <b>CoNt:</b> Continue run profile <b>PV:</b> Continue run profile from current PV <b>Hold:</b> Hold profile <b>SToP:</b> Stop profile	<b>StAR</b>
	117	RMPU	Unit for Ramp/soak time	<b>HH.MM:</b> Hours. Minutes <b>MM.SS:</b> Minutes. Seconds	<b>HH.MM</b>
	118	STAR	Set point value at start of each profile	<b>PV:</b> Current process value PV <b>SP1:</b> Controller set point value SP1	<b>PV</b>
	119	END	Set point value at end of each profile	<b>SP1:</b> Controller set point value SP1	0°F
	120	PFR	Power fail recovery	<b>CoNt:</b> Continue profile from the last set point value <b>PV:</b> Start to run from PV <b>SP1:</b> Static mode, SP1	SP1
	121	HBLO	Holdback low band	Low: 0.1°C High:500.0°C(900.0°F) 0.0 = No low band: NoNE	0.0
	122	HBHI	Holdback high band	Low: 0.1°C High: 500.0°C(900.0°F) 0.0 =No high band: NoNE	0.0

↑  
Profile Menu  
↓

Register Address	Parameter Notation	Parameter Description	Range	Default Value
123	HBT	Holdback time	Low: 00.00 (Hour. Minute) High: 99.99 (Hour. Minute) 10000 = inFi : Infinite	00.00
124	CYCL	Repeat number of cycles for the profile	Low: 1 High: 9999 10000 = inFi : Infinite	1
125	CYCR	Cycle remaining for the profile	Low: 1 High: 9999 10000 = inFi : Infinite	1
126	TSP1	Target set point for segment 1	Low: SP1L High: SP1H	212.0°F
127	RPT1	Ramp time of segment 1	Low: 00.00 High: 99.59	00.00
128	SKT1	Soak time of segment 1	Low: 00.00 High: 99.59	00.00
129	TSP2	Target set point for segment 2	Low: SP1L High: SP1H	212.0°F
130	RPT2	Ramp time of segment 2	Low: 00.00 High: 99.59	00.00
131	SKT2	Soak time of segment 2	Low: 00.00 High: 99.59	00.00
132	TSP3	Target set point for segment 3	Low: SP1L High: SP1H	212.0°F
133	RPT3	Ramp time of segment 3	Low: 00.00 High: 99.59	00.00
134	SKT3	Soak time of segment 3	Low: 00.00 High: 99.59	00.00
135	TSP4	Target set point for segment 4	Low: SP1L High: SP1H	212.0°F
136	RPT4	Ramp time of segment 4	Low: 00.00 High: 99.59	00.00
137	SKT4	Soak time of segment 4	Low: 00.00 High: 99.59	00.00
140	TSP5	Target set point for segment 5	Low: SP1L High: SP1H	212.0°F
141	RPT5	Ramp time of segment 5	Low: 00.00 High: 99.59	00.00
142	SKT5	Soak time of segment 5	Low: 00.00 High: 99.59	00.00
143	TSP6	Target set point for segment 6	Low: SP1L High: SP1H	212.0°F

Profile Menu

Register Address	Parameter Notation	Parameter Description	Range	Default Value
144	RPT6	Ramp time of segment 6	Low: 00.00 High: 99.59	00.00
145	SKT6	Soak time of segment 6	Low: 00.00 High: 99.59	00.00
146	TSP7	Target set point for segment 7	Low: SP1L High: SP1H	212.0°F
147	RPT7	Ramp time of segment 7	Low: 00.00 High: 99.59	00.00
148	SKT7	Soak time of segment 7	Low: 00.00 High: 99.59	00.00
149	TSP8	Target set point for segment 8	Low: SP1L High: SP1H	212.0°F
150	RPT8	Ramp time of segment 8	Low: 00.00 High: 99.59	00.00
151	SKT8	Soak time of segment 8	Low: 00.00 High: 99.59	00.00
152	RPT9	Ramp time of segment 9	Low: 00.00 High: 99.59	00.00
153	SKT9	Soak time of segment 9	Low: 00.00 High: 99.59	00.00
154	TSPA	Target set point for segment 10	Low: SP1L High: SP1H	212.0°F
155	RPTA	Ramp time of segment 10	Low: 00.00 High: 99.59	00.00
161	SKTA	Soak time of segment 10	Low: 00.00 High: 99.59	00.00
162	TSPB	Target set point for segment 11	Low: SP1L High: SP1H	212.0°F
163	RPTB	Ramp time of segment 11	Low: 00.00 High: 99.59	00.00
164	SKTB	Soak time of segment 11	Low: 00.00 High: 99.59	00.00
165	TSPC	Target set point for segment 12	Low: SP1L High: SP1H	212.0°F
166	RPTC	Ramp time of segment 12	Low: 00.00 High: 99.59	00.00
167	SKTC	Soak time of segment 12	Low: 00.00 High: 99.59	00.00
168	TSPD	Target set point for segment 13	Low: SP1L High: SP1H	212.0°F

Profile Menu

Register Address	Parameter Notation	Parameter Description	Range	Default Value
169	RPTD	Ramp time of segment 13	Low: 00.00 High: 99.59	00.00
170	SKTD	Soak time of segment 13	Low: 00.00 High: 99.59	00.00
171	TSPE	Target set point for segment 14	Low: SP1L High: SP1H	212.0°F
172	RPTE	Ramp time of segment 14	Low: 00.00 High: 99.59	00.00
173	SKTE	Soak time of segment 14	Low: 00.00 High: 99.59	00.00
174	TSPF	Target set point for segment 15	Low: SP1L High: SP1H	212.0°F
175	RPTF	Ramp time of segment 15	Low: 00.00 High: 99.59	00.00
176	SKTF	Soak time of segment 15	Low: 00.00 High: 99.59	00.00
177	TSPG	Target set point for segment 16	Low: SP1L High: SP1H	212.0°F
178	RPTG	Ramp time of segment 16	Low: 00.00 High: 99.59	00.00
179	SKTG	Soak time of segment 16	Low: 00.00 High: 99.59	00.00

## 2 Installation and Wiring

 Sometimes dangerous voltages capable of causing death are present in this instrument. Before doing installation or any troubleshooting procedures, the power to the equipment must be switched off and isolated. Units suspected of being faulty must be disconnected and removed to a properly equipped workshop for testing and repair. Component replacement and internal adjustments must be made by a qualified maintenance person only.

 To minimize the possibility of fire or shock hazards, do not expose this instrument to rain or excessive moisture.

 Do not use this instrument in areas under hazardous conditions such as excessive shock, vibration, dirt, moisture, corrosive gases or oil. The ambient temperature of the area should not exceed the maximum rating specified in the specification

 Remove stains from this equipment using a soft, dry cloth. Do not use harsh chemicals, volatile solvents such as thinner or strong detergents to clean the equipment in order to avoid deformation.

### 2.1 Unpacking

Upon receipt of the shipment, remove the controller from the carton and inspect the unit for shipping damage. If any damage is found, contact your local representative immediately. Note the model number and serial number for future reference when corresponding with our service center. The serial number (S/N) is labeled on the box and the housing of the controller.

The controller is designed for indoor use only, and is not intended for use in any hazardous area. It should be kept away from shock, vibration, and electromagnetic fields (such as variable frequency drives), motors and transformers. It is intended to operate under the following environmental conditions.

Environmental Parameter	Specification
Operating Temperature	-10°C to 50 °C
Humidity	0% to 90% RH(Non-condensing)
Altitude	2000 M Maximum

#### *2-1. Environmental Specification*

### 2.2 Mounting

Make the panel cut out as per the dimensions required by the controller. The dimensions of the different sizes of this series controller series are given in the following section. Remove the mounting clamps from the controller and insert the controller into the panel cut out. After inserting the controller into the panel cut out, re-install the mounting clamps. Gently tighten the clamp screws until the controller is properly secured into the cutout.

## 2.2.1 TEC-2400 Dimension

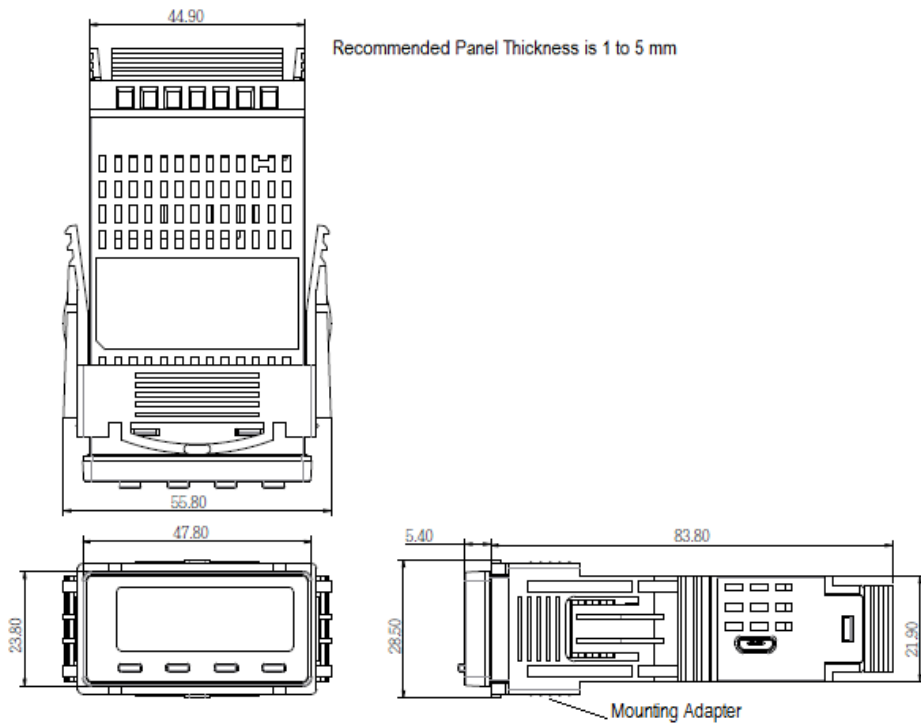

### 2-1. TEC-2400 Dimensions with clamp

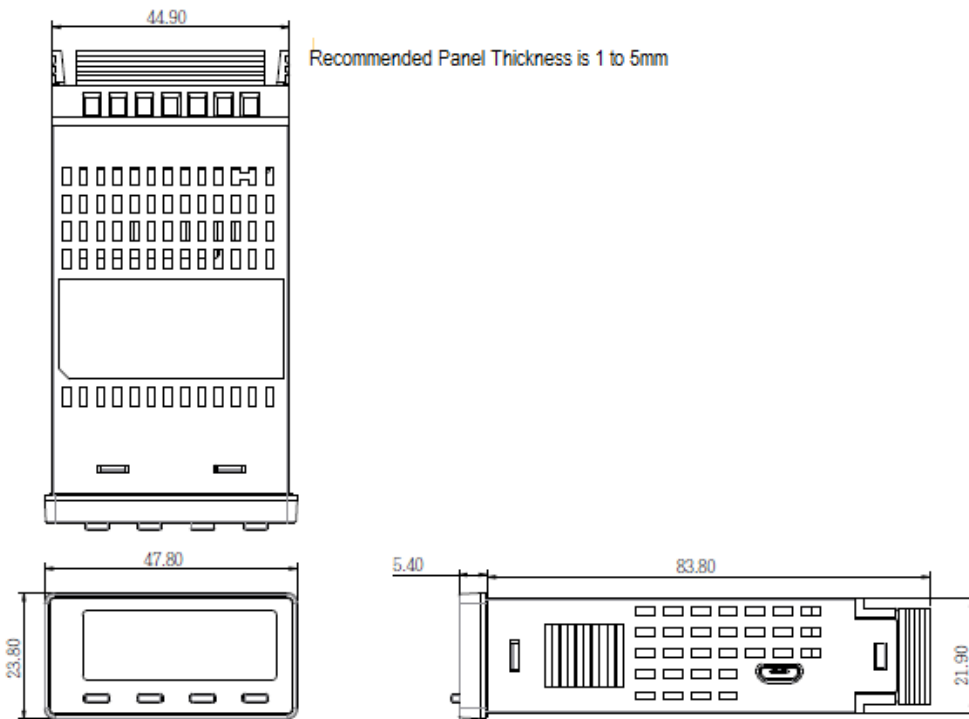

### 2-2. TEC-2400 Dimension without Clamp

## 2.2.2 TEC-9400 Dimension

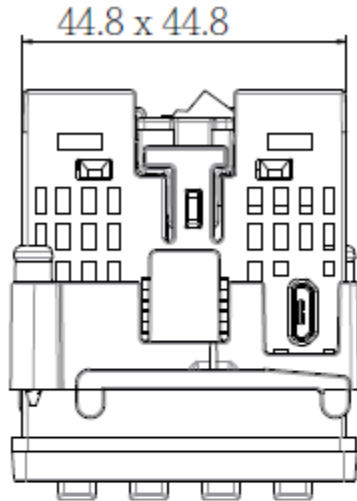

Recommended Panel Thickness is 1 to 5mm

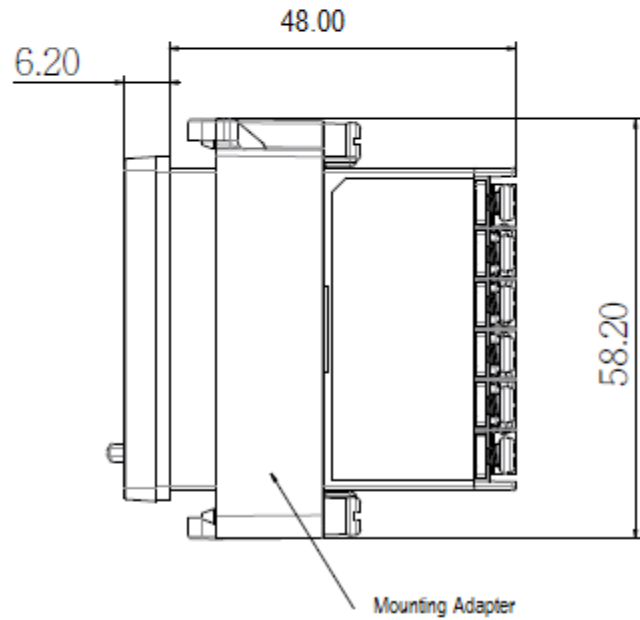
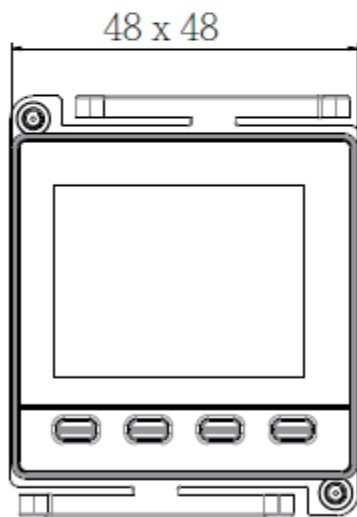

### 2-3. TEC-9400 Dimension with clamp

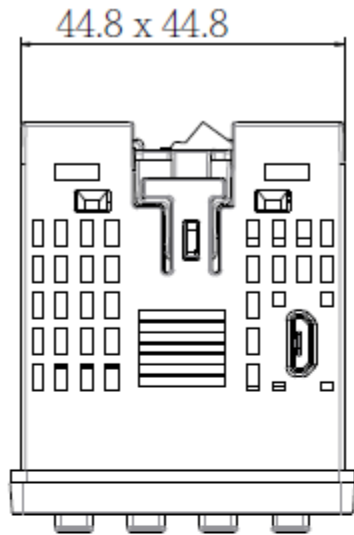

Recommended Panel Thickness is 1 to 5mm

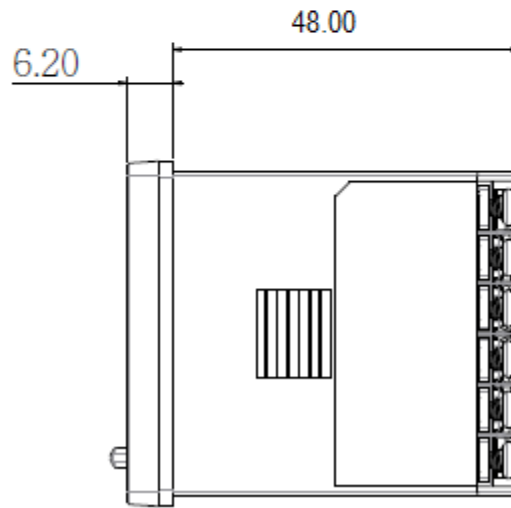
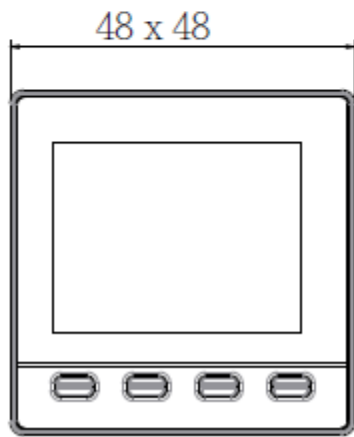

**2-4. TEC-9400 Dimension without Clamp**

### 2.2.3 TEC-8400 Dimension

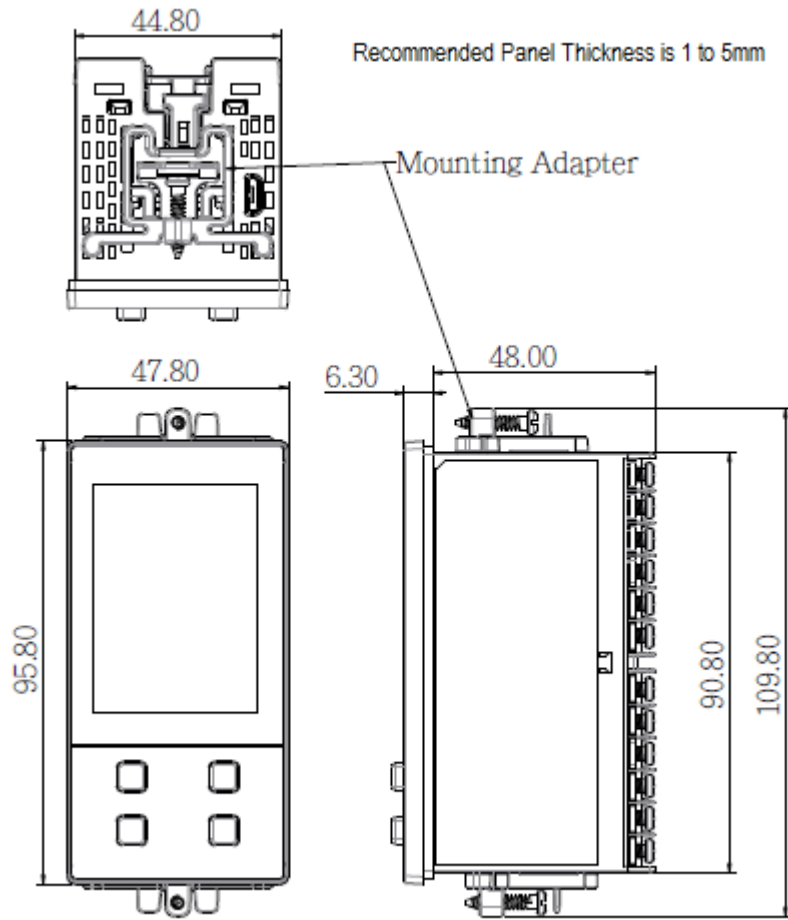

**2-5.TEC-8400 Dimension with Clamp**

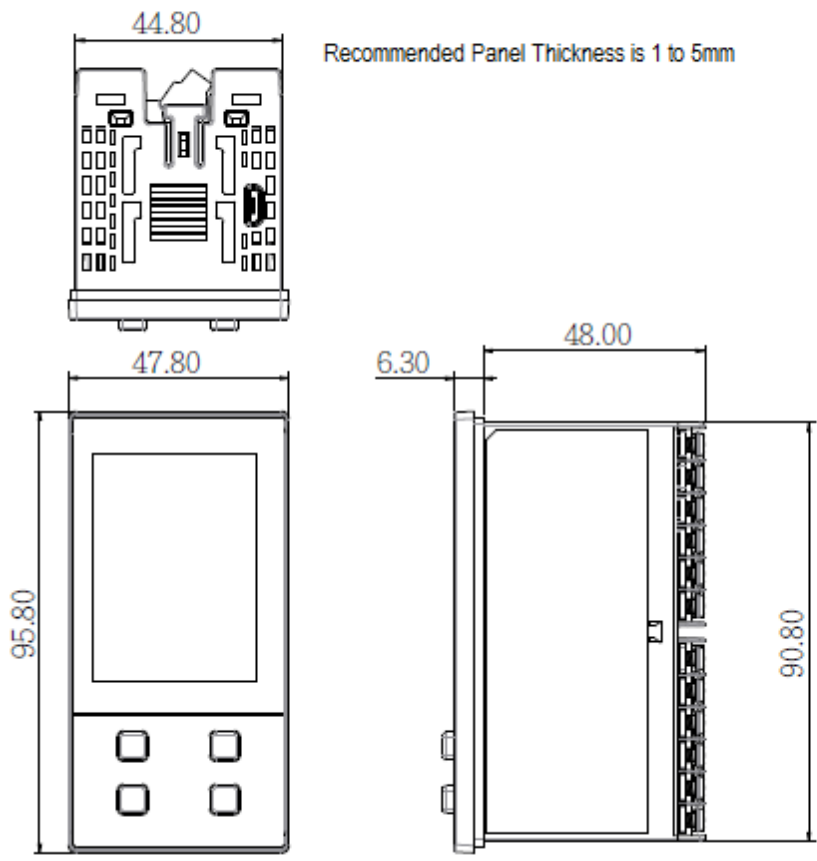

***2-6.TEC-8400 Dimension without Clamps***

## 2.2.4 TEC-8450 Dimension

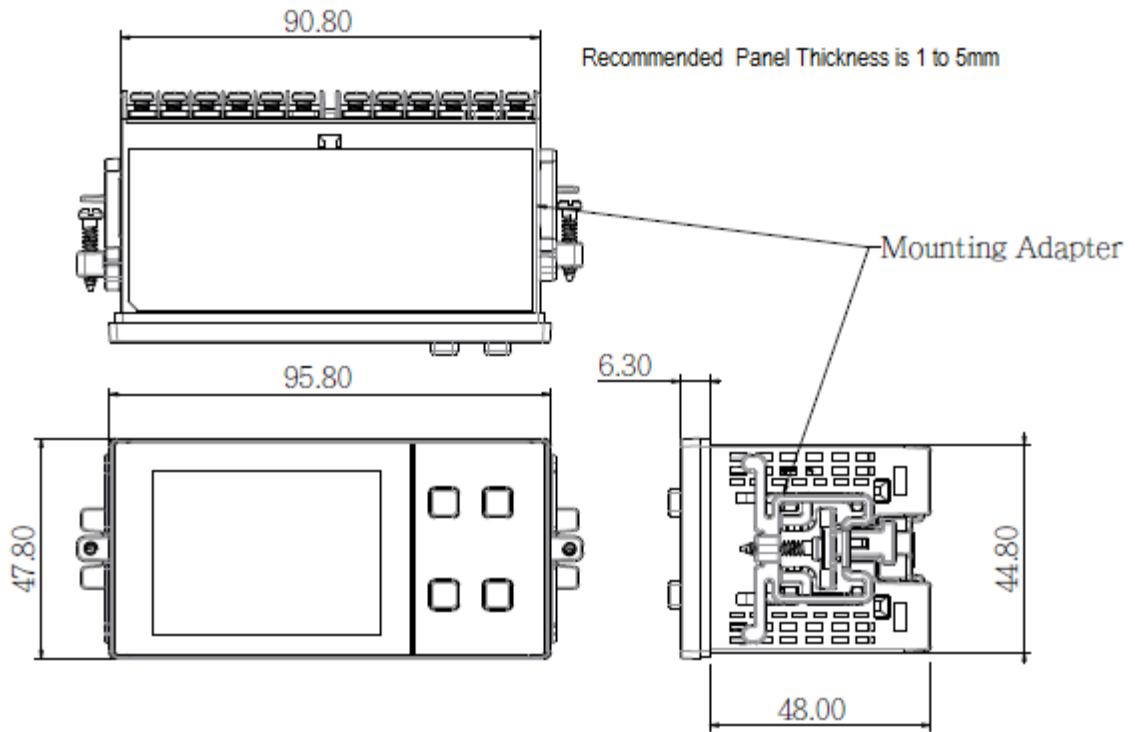

**2-7.TEC-8450 Dimension with Clamps**

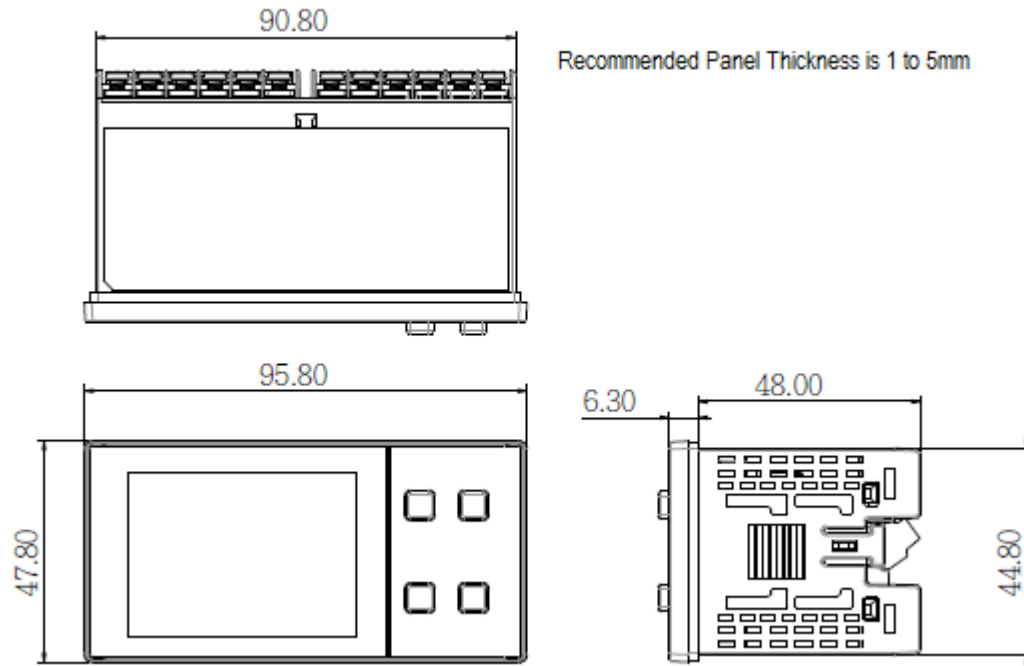

**2-8.TEC-8450 Dimension without Clamp**

## 2.2.5 TEC-7400 Dimension

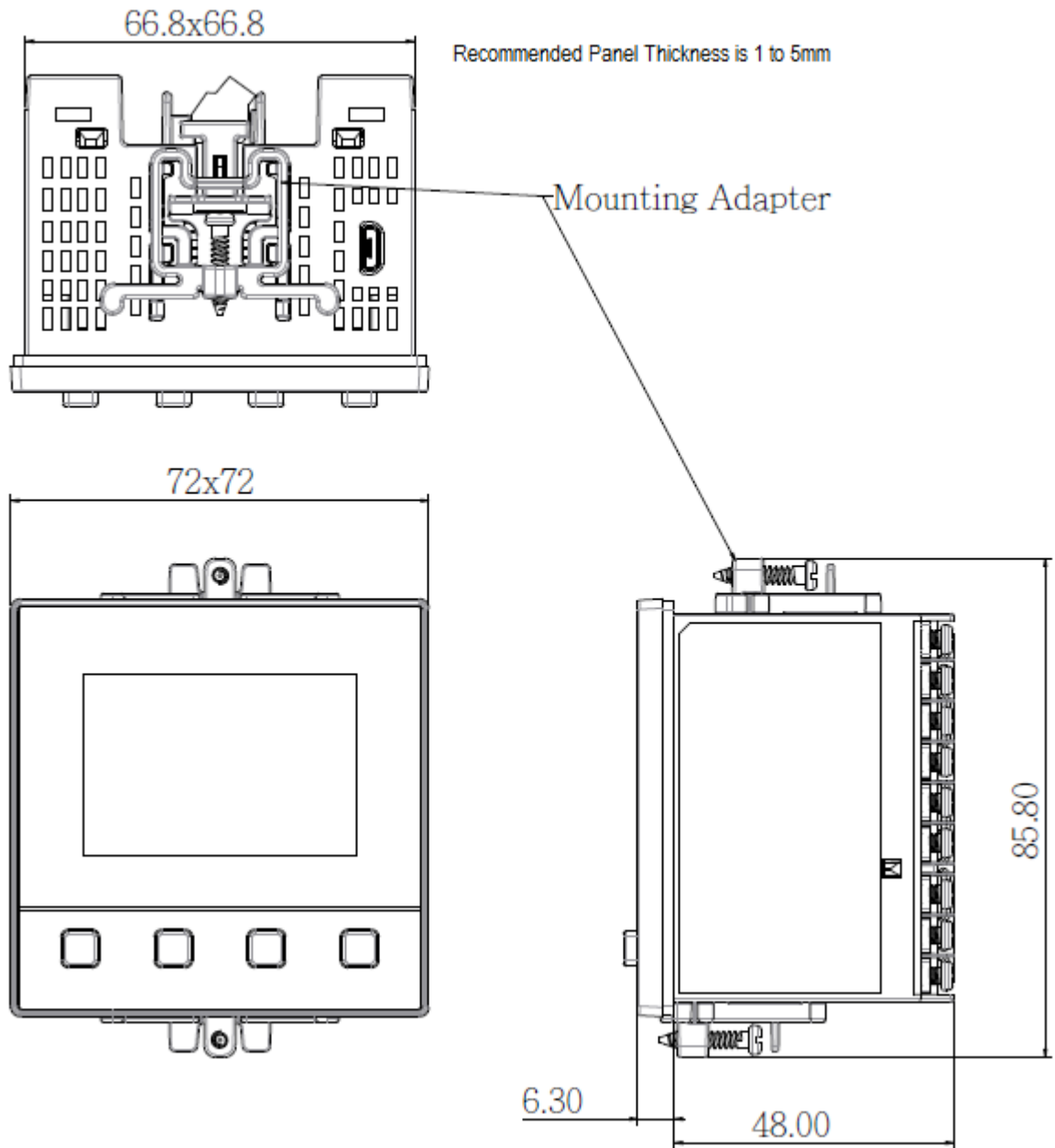

**2-9.TEC-7400 Dimension with Clamp**

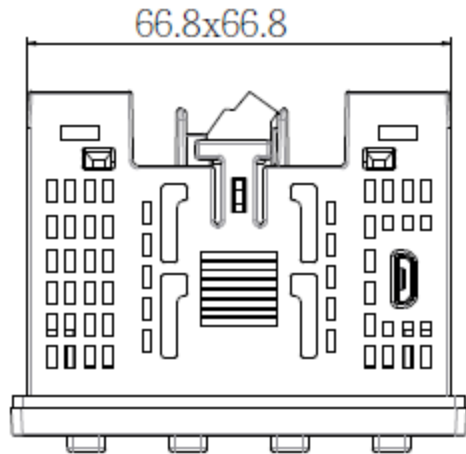

Recommended Panel Thickness is 1 to 5mm

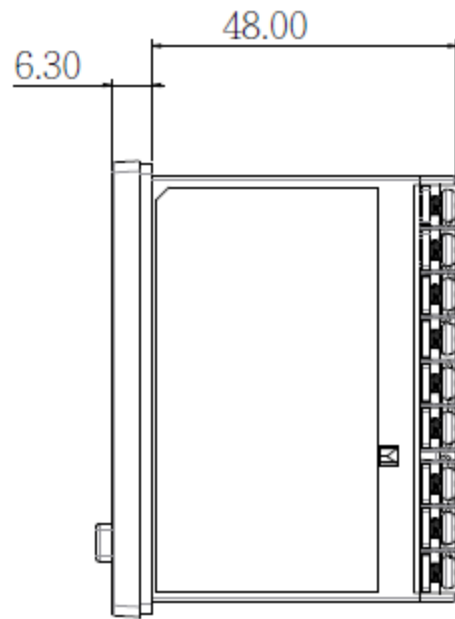
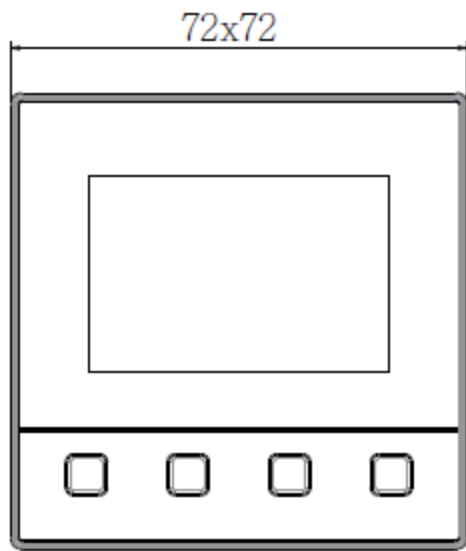

**2-10.TEC-7400 Dimension without Clamp**

## 2.2.6 TEC-4400 Dimension

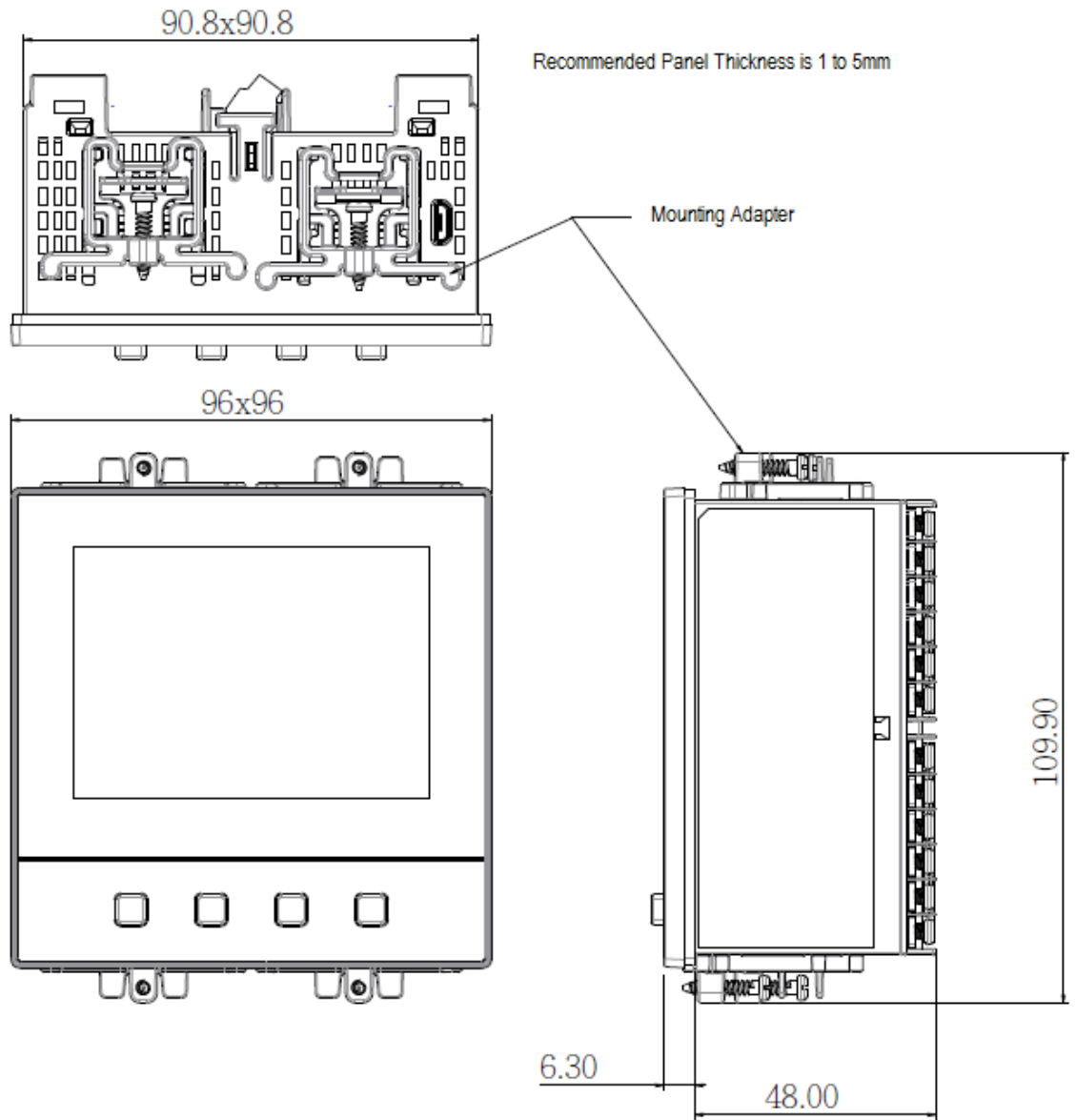

**2-11. TEC-4400 Dimension with Clamps**

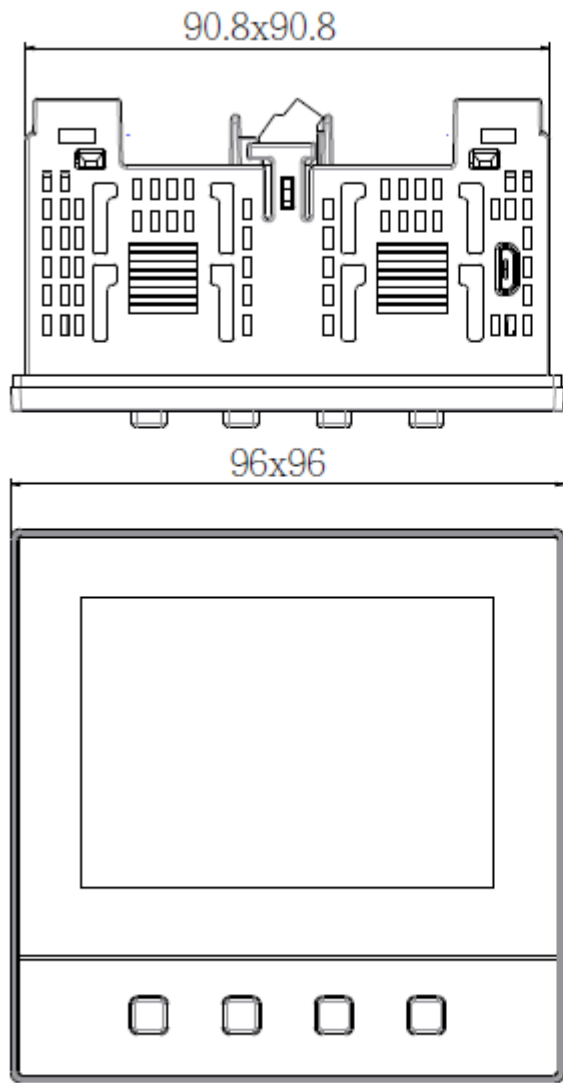

Recommended Panel Thickness is 1 to 5mm

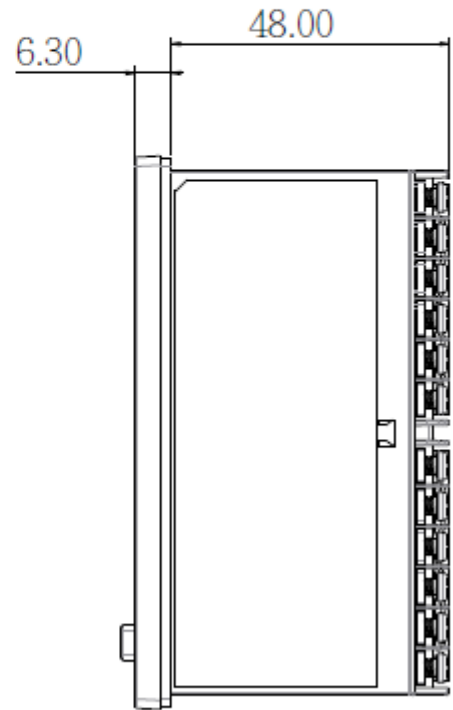

**2-12. TEC-4400 Dimension without Clamp**

### 2.2.7 TEC-6400 Dimension

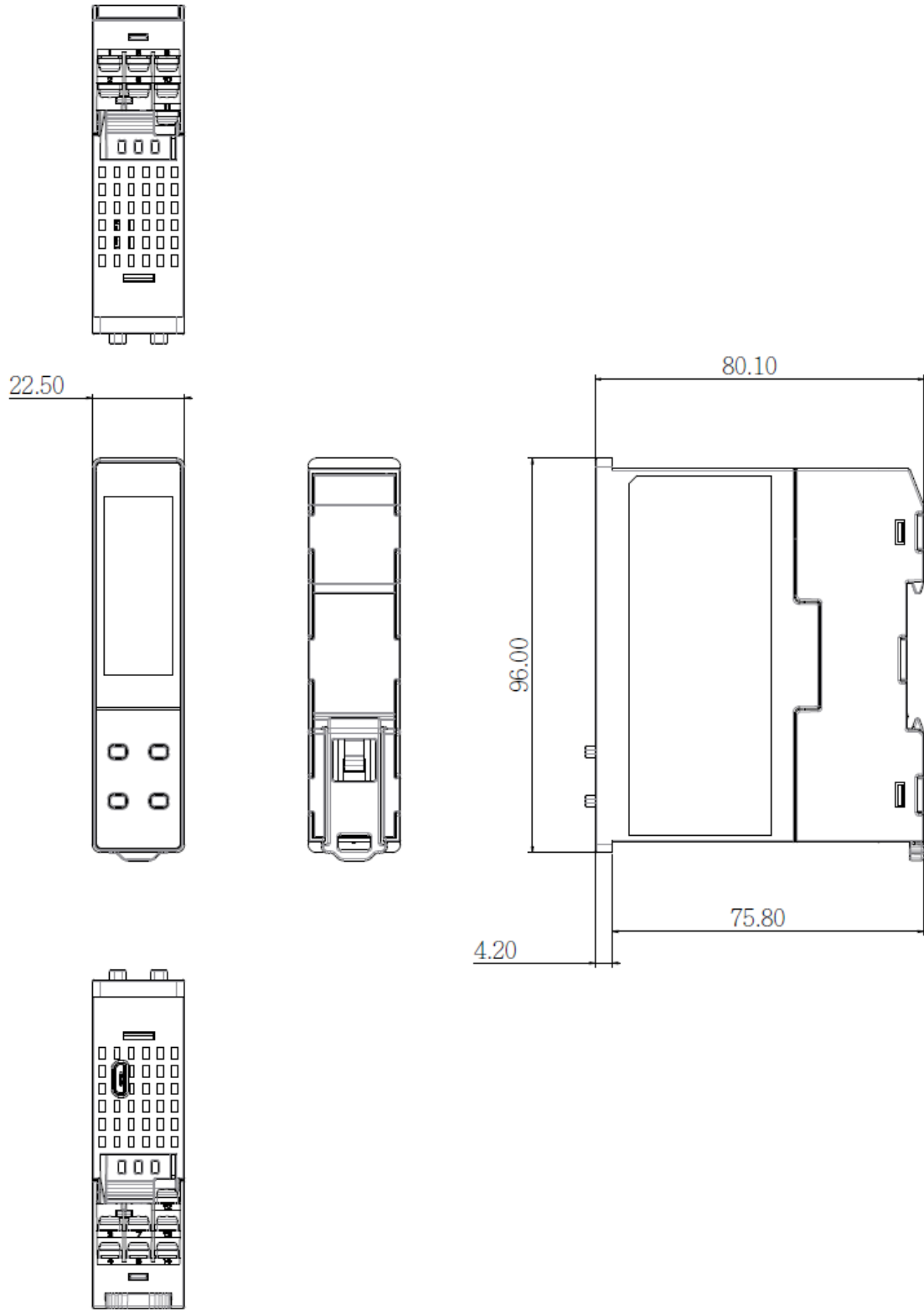

**2-13.TEC-6400 Dimension**

## 2.3 Wiring

**⚠** Sometimes dangerous voltages capable of causing death are present in this instrument. Before doing installation or any troubleshooting procedures, the power to the equipment must be switched off and isolated. Units suspected of being faulty must be disconnected and removed to a properly equipped workshop for testing and repair. Component replacement and internal adjustments must be made by a qualified maintenance person only.

The utmost care must be taken to ensure that the maximum voltage rating specified on the label is not exceeded.

It is recommended that the supply power of these units be protected by fuses or circuit breakers rated at the lowest value possible

All units should be installed inside a suitably grounded metal enclosure to prevent live parts being accessible to human hands and metal tools.

All wiring must conform to appropriate standards of good practice and local codes and regulations. Wiring must be suitable for the voltage, current, and temperature rating of the system.

The tightening torque on the Screw terminals should not exceed 1 N-m (8.9 Lb-in or 10.2 Kg F-cm).

Except Thermocouple Wiring, all other wires used are to be standard copper conductors with the maximum Gauge not exceeding 18AWG.

Before power on the controller, the equipment ground must be connected with minimum of 1.6mm diameter conductor for protective grounding.

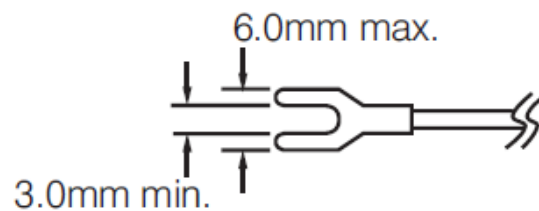

**2-14. Lead Terminal for all models except TEC-2400**



**2-15. Lead Terminal for TEC-2400**

### 2.3.1 TEC-2400 Terminal Connection

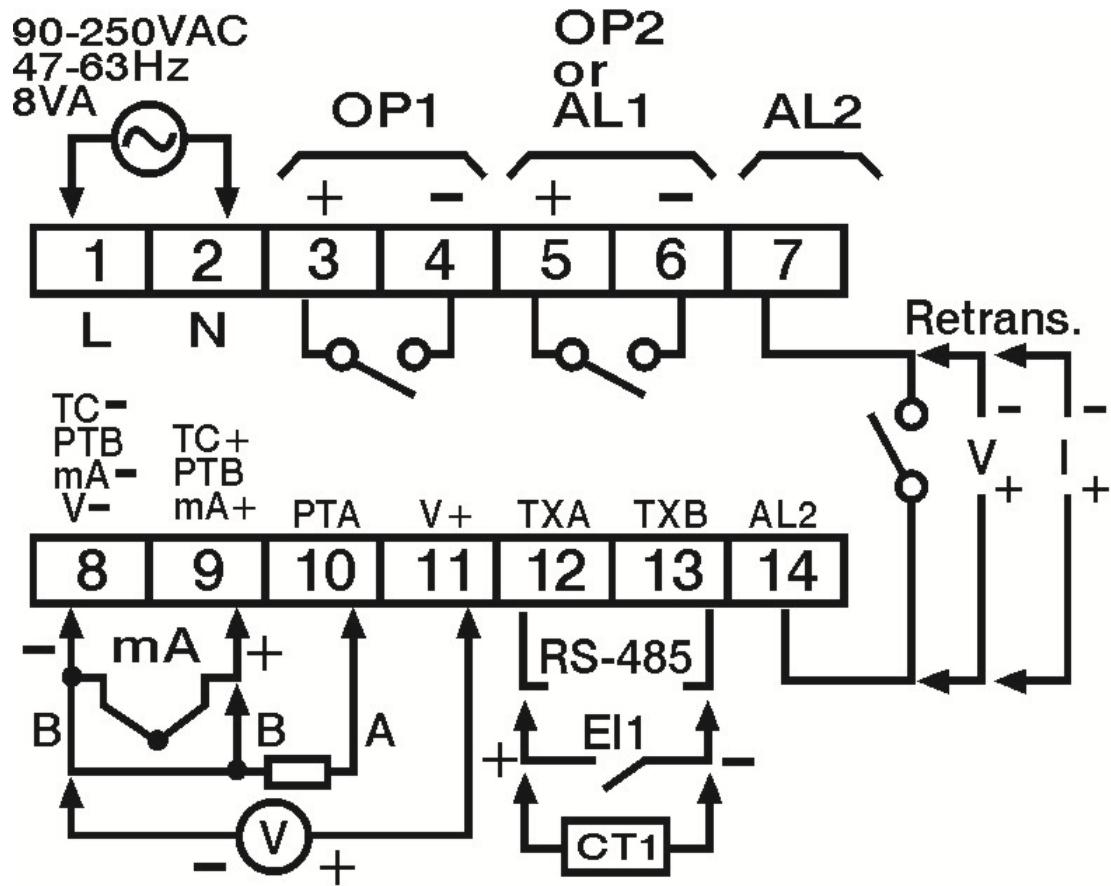

2-16. TEC-2400 Rear Terminal Connection

### 2.3.2 TEC-9400 Terminal Connection

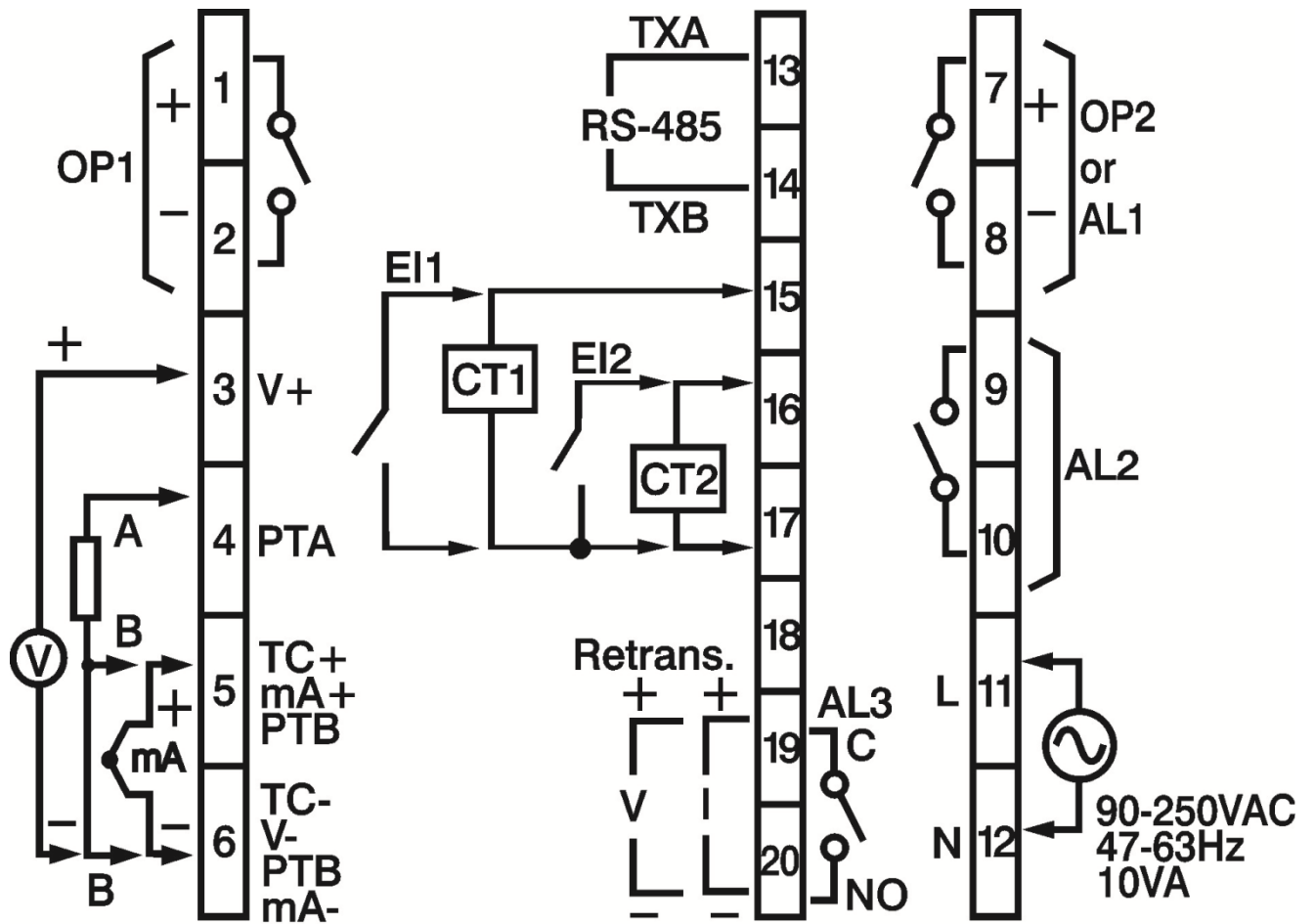

2-17. TEC-9400 Rear Terminal Connection

### 2.3.3 TEC-8400 & TEC-4400 Terminal Connection

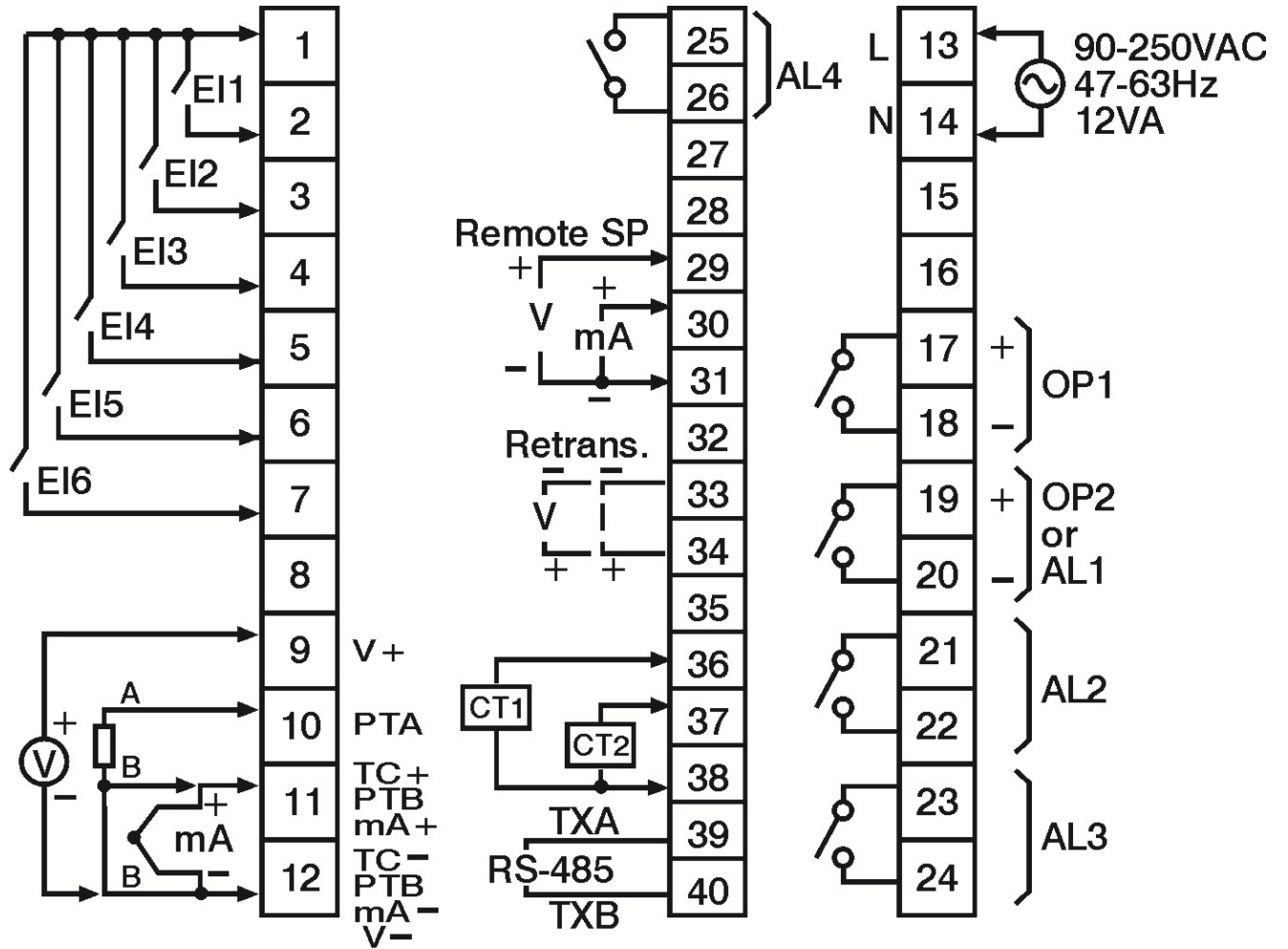

2-18. TEC-8400 & TEC-4400 Rear Terminal Connection

### 2.3.4 TEC-8450 Terminal Connection

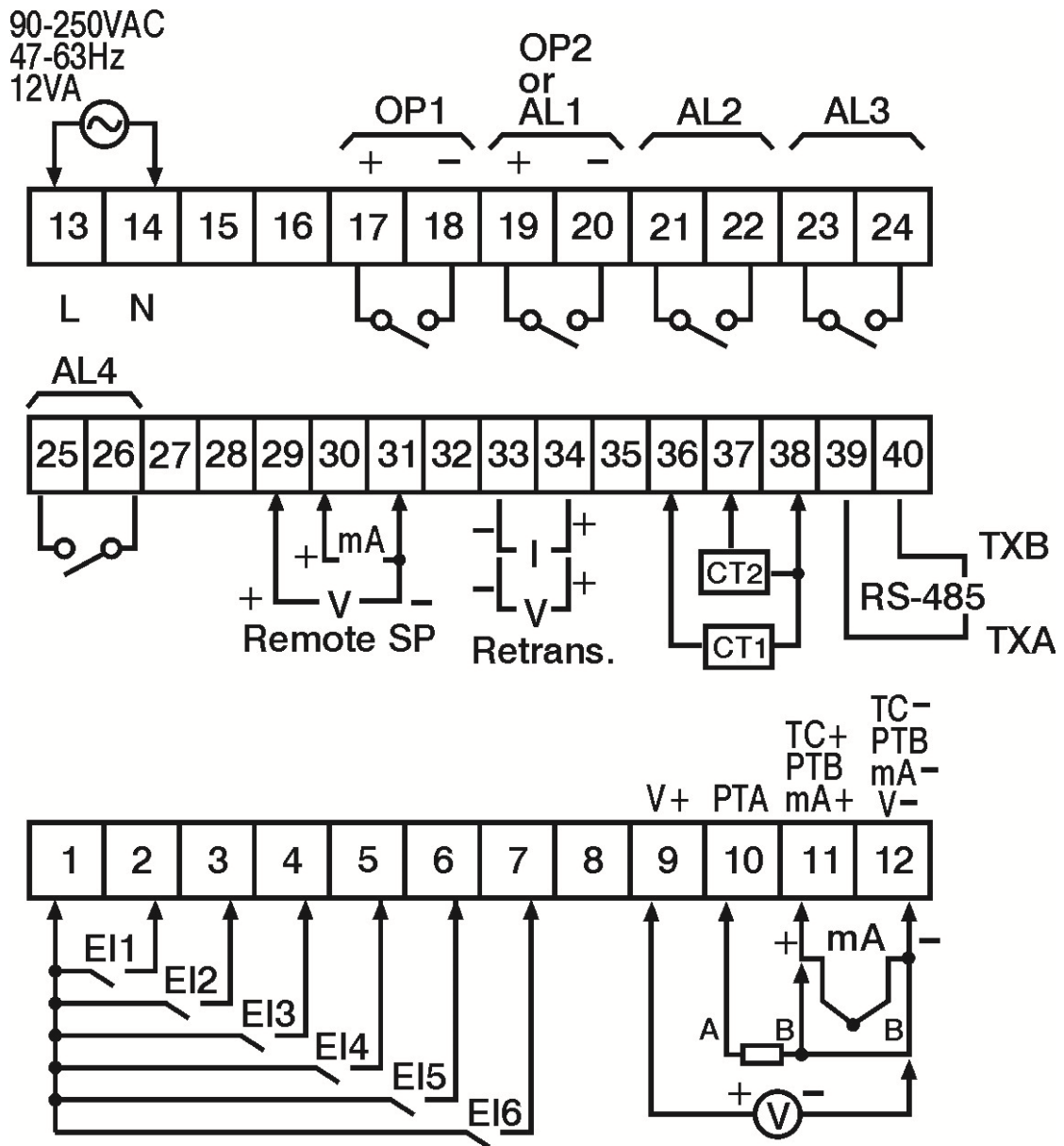

2-19. TEC-8450 Rear Terminal Connection

### 2.3.5 TEC-7400 Terminal Connection

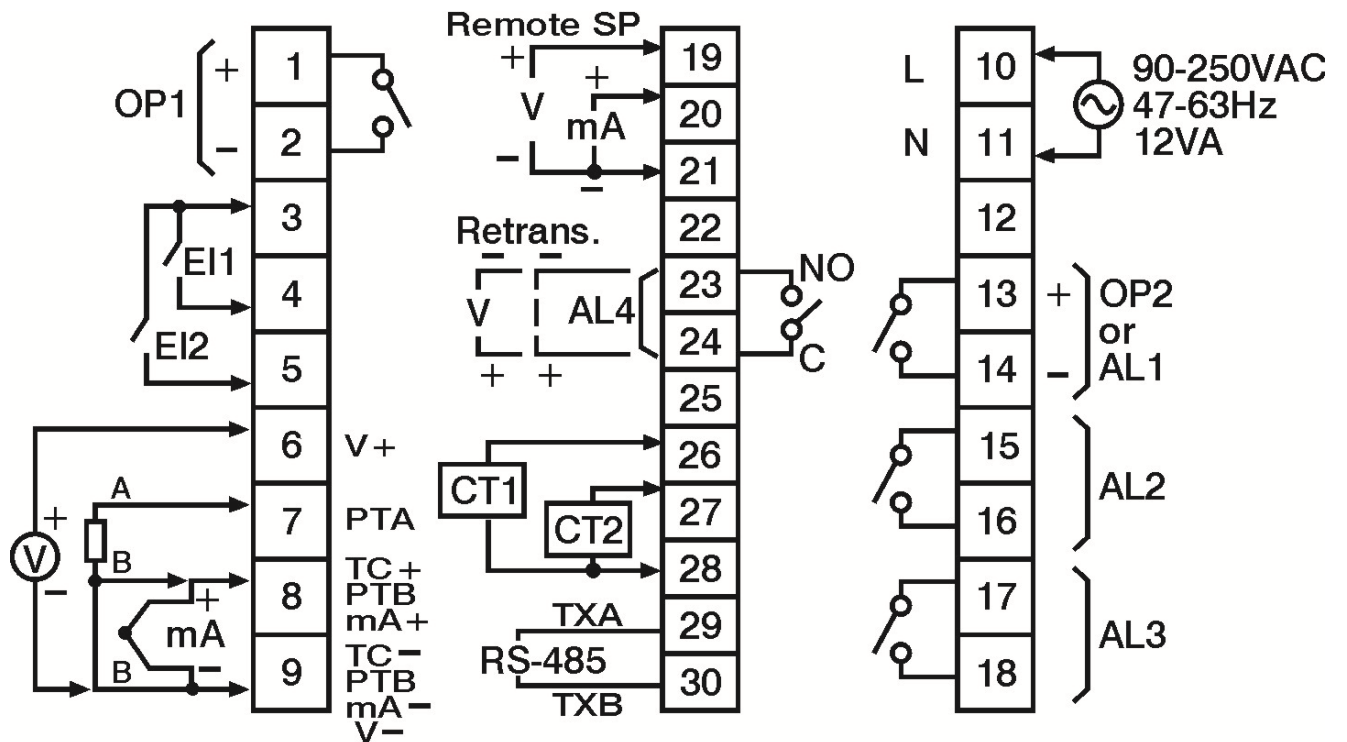

2-20.TEC-7400 Rear Terminal Connection

### 2.3.6 TEC-6400 Terminal Connection

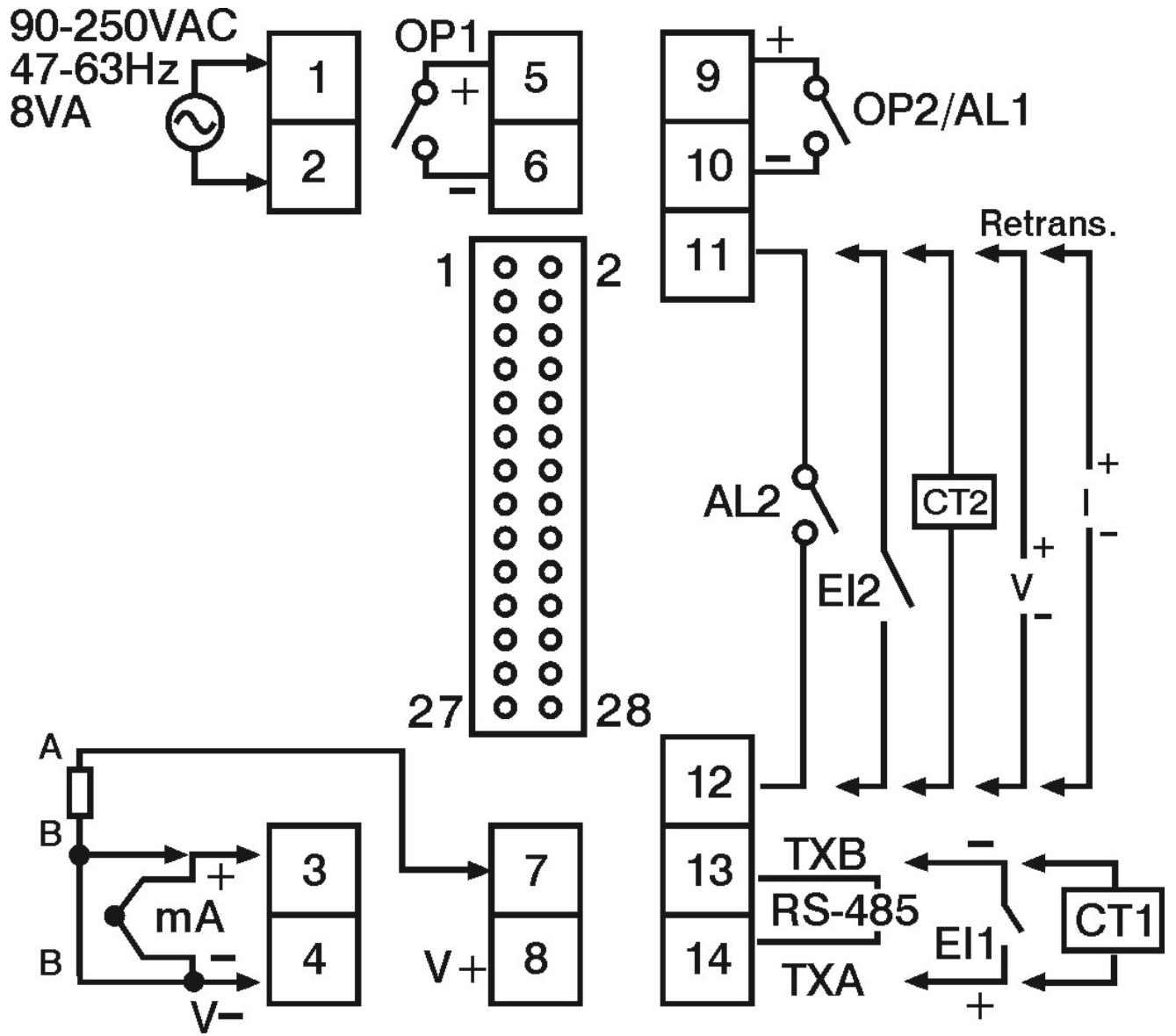

2-21.TEC-6400 Terminal Connection

## 2.4 Power Wiring

The controller is designed to operate at either 11-26VAC/VDC or 90-250VAC depending on power input option ordered. Check that the installation voltage corresponds with the power rating indicated on the product label before connecting power to the controller. Near the controller, a fuse and a switch rated at 2A/250VAC should be equipped as shown below.

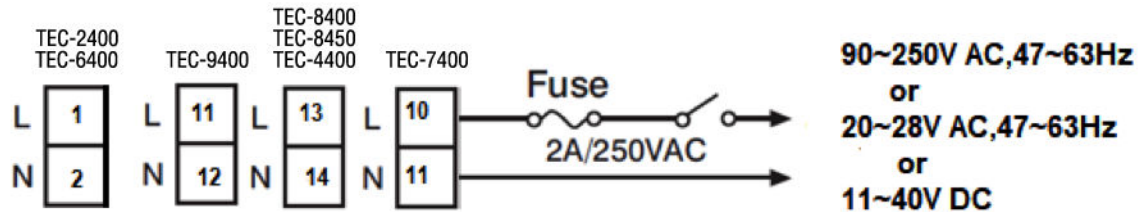

### 2-22. Power Wiring

**⚠** This equipment is designed for installation in an enclosure which provides adequate protection against electric shock. The enclosure must be connected to earth ground.

**⚠** Local requirements regarding electrical installation should be rigidly observed. Consideration should be given to prevent from unauthorized persons from accessing the power terminals.

## 2.5 Sensor Installation

Proper sensor installation can eliminate many problems in a control system. The probe should be placed so that it can detect any temperature change with minimal thermal lag. In a process that requires fairly constant heat output, the probe should be placed close to the heater. In a process where the heat demand is variable, the probe should be closed to the work area. Some experiments with probe location are often required to find this optimum position.

In a liquid process, the addition of a stirrer or agitator can help to eliminate thermal lag. Since the thermocouple is basically a point measuring device, placing more than one thermocouple in parallel can provide average temperature readout and produce better results in most air heated processes.

Proper sensor type is also a very important factor to obtain precise measurements. The sensor must have the correct temperature range to meet the process requirements. In special processes, the sensor might need to have different requirements such as being leak-proof, ant vibration, antiseptic, etc.

Standard sensor limits of error are  $\pm 4^{\circ}\text{F}$  ( $\pm 2^{\circ}\text{C}$ ) or 0.75% of sensed temperature (half that for special) plus drift caused by improper protection or an over-temperature occurrence. This error is far greater than controller error and cannot be corrected on the sensor except by proper selection and replacement.

## 2.6 Sensor Input Wiring

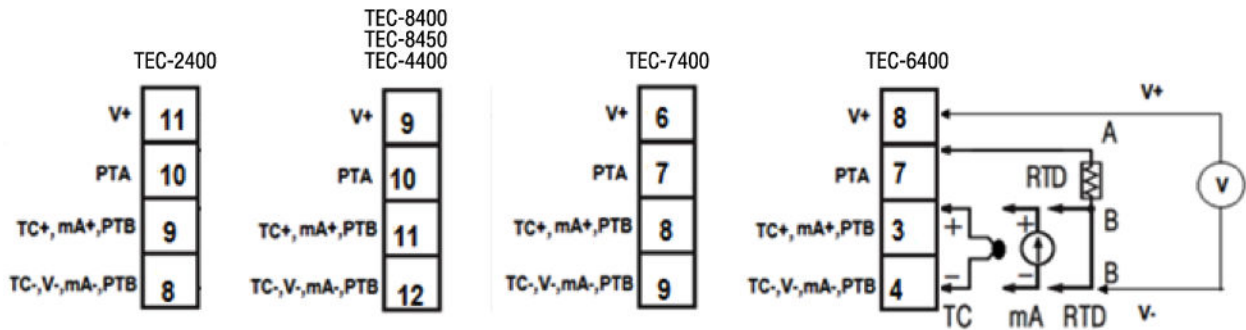
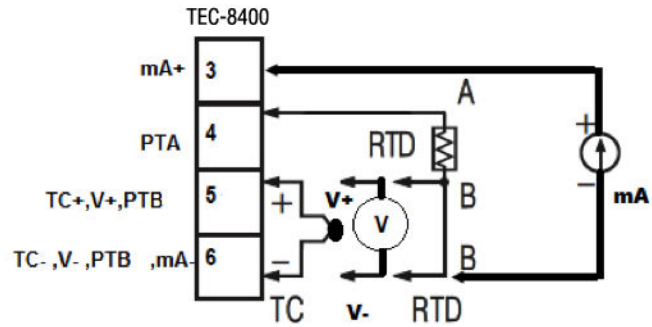

2-23. Sensor Input Wiring

## 2.7 Control Output Wiring

### 2.7.1 Output 1

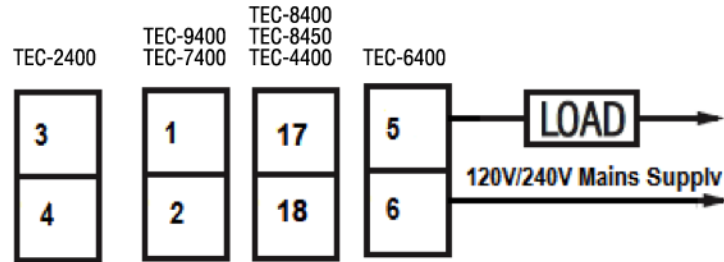

2-24. Output 1 Relay to Drive Load

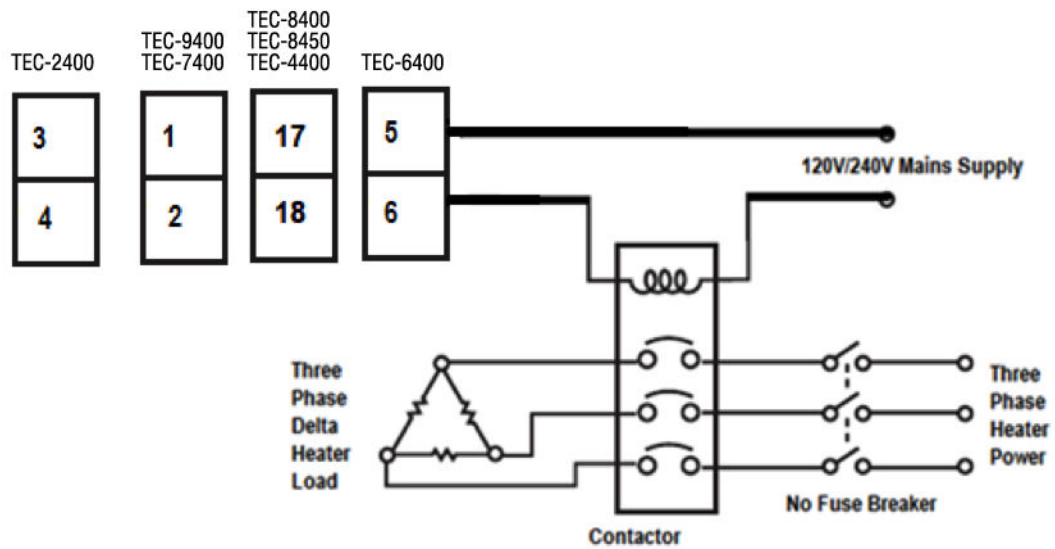

2-25. Output 1 Relay to Drive Contactor

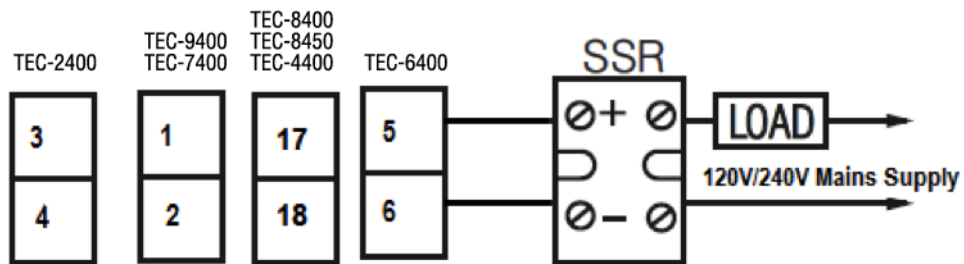

**2-26. Output 1 Pulsed voltage to Drive SSR**

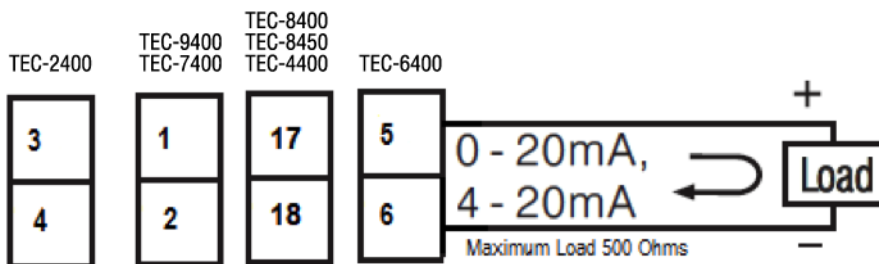

**2-27. Output 1 Linear Current Control**

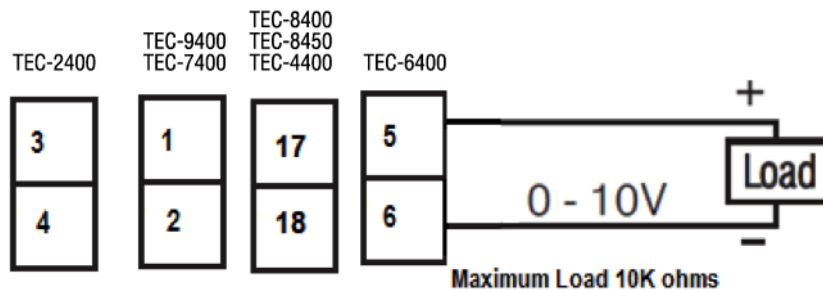

**2-28. Output 1 Linear Voltage Control**

## 2.7.2 Output 2

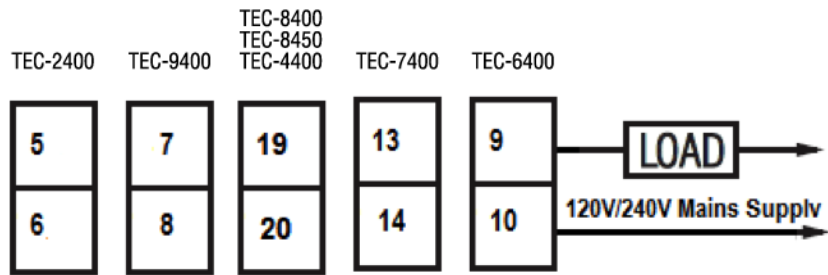

2-29. Output 2 Relay to Drive Load

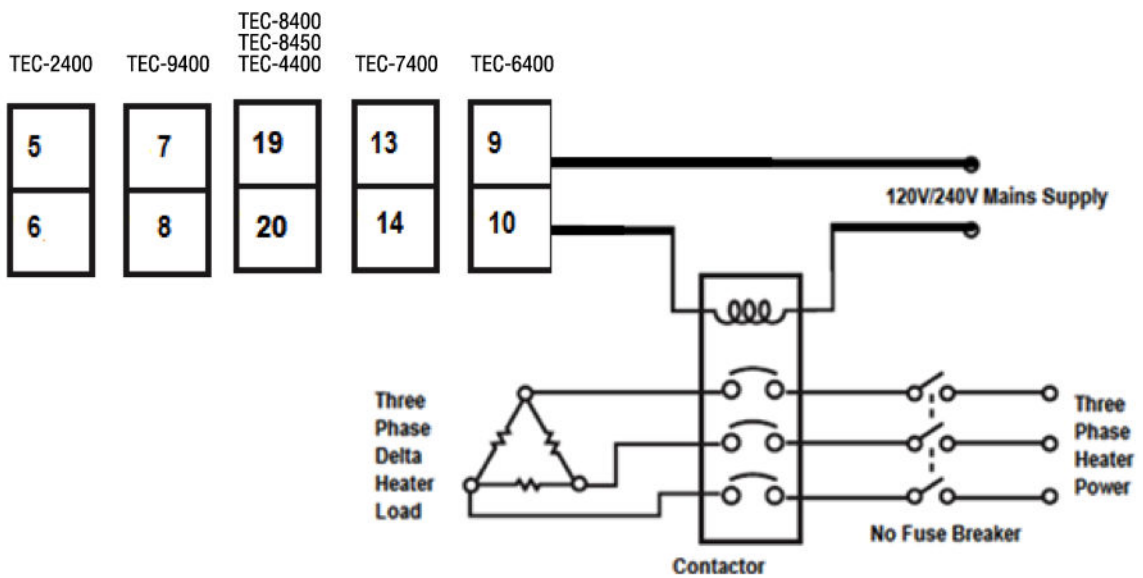

2-30. Output 2 Relay to Drive Contactor

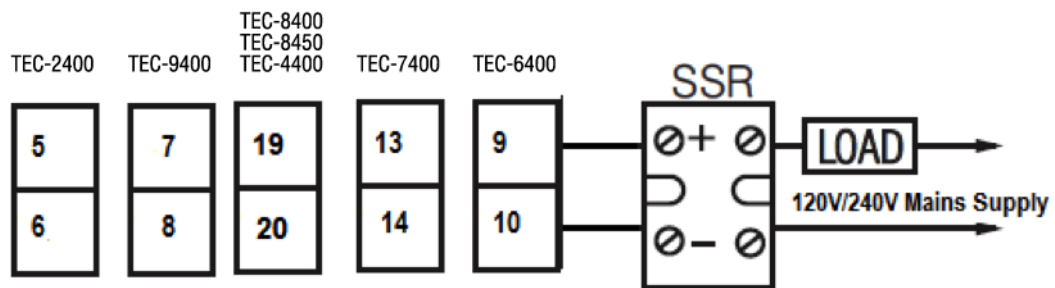

2-31. Output 2 Pulsed Voltage to Drive SSR

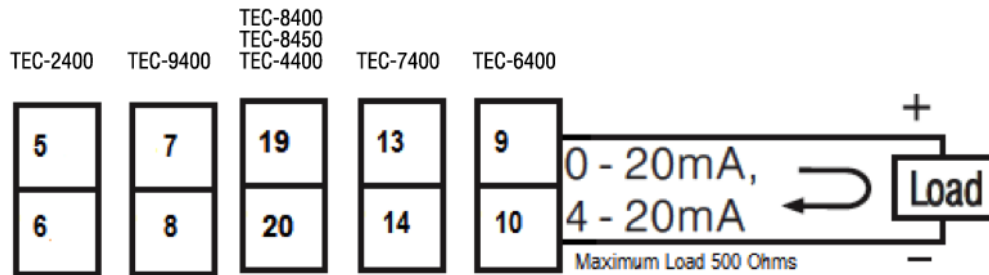

2-32. Output 2 Linear Current Control

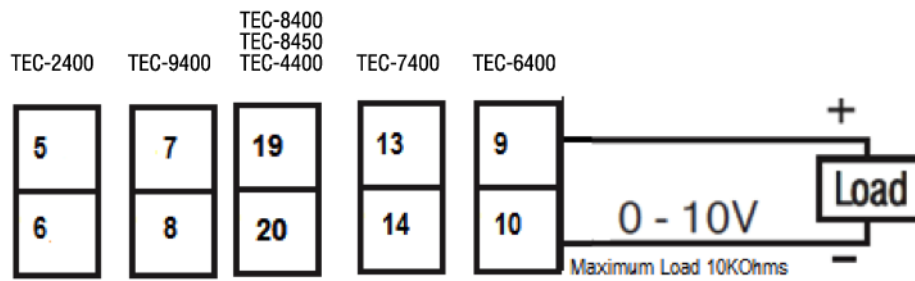

2-33. Output 2 Linear Voltage Control

## 2.8 Alarm Wiring

### 2.8.1 Alarm 1

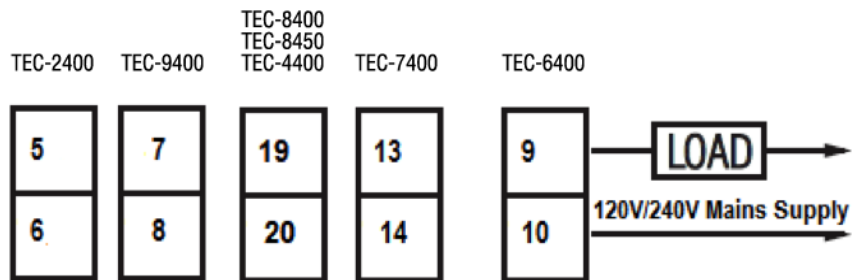

2-34. Alarm 1 Output to Drive Load

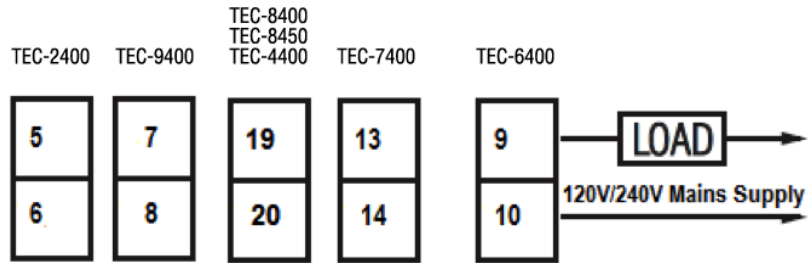

2-35. Alarm 1 Output to Drive Contactor

2.8.2 Alarm 2

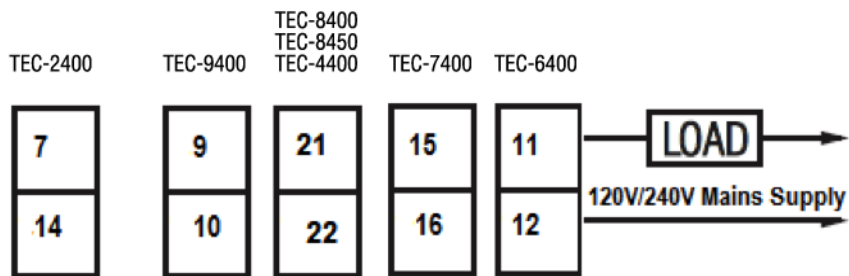

2-36. Alarm 2 Output to Drive Load

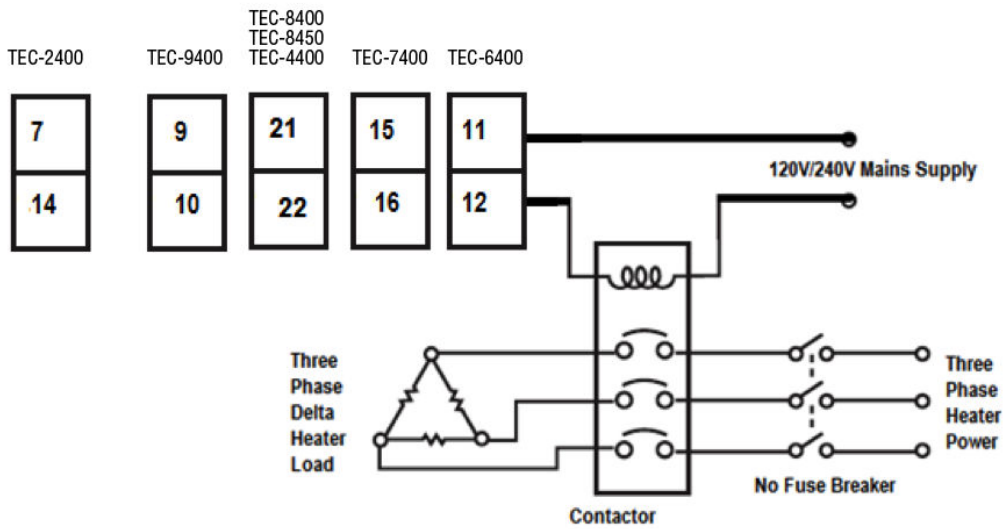

2-37. Alarm 2 Output to Drive Contactor

### 2.8.3 Alarm 3

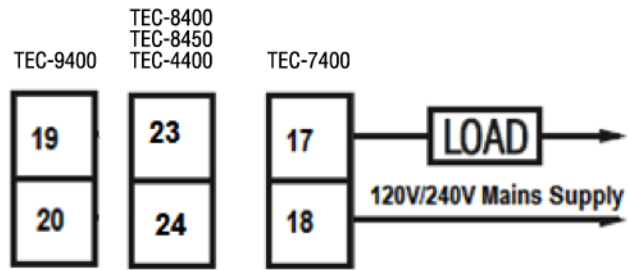

2-38. Alarm 3 Output to Drive Load

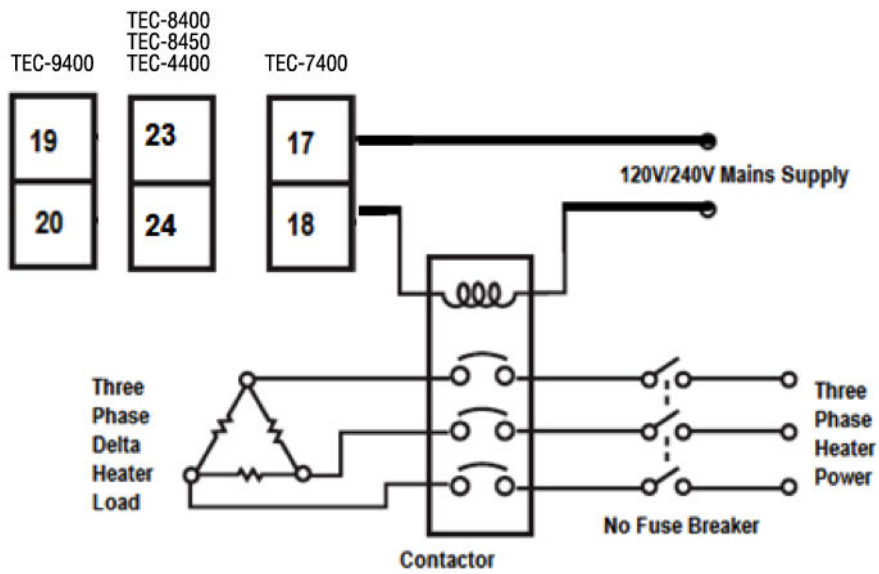

2-39. Alarm 3 Output to Drive Contactor

## 2.8.4 Alarm 4

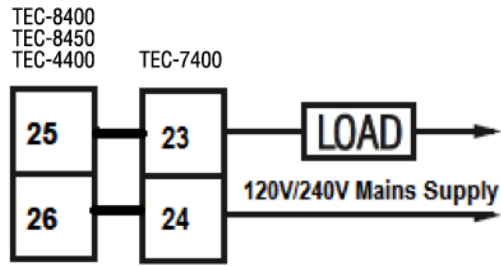

2-40. Alarm 4 Output to Drive Load

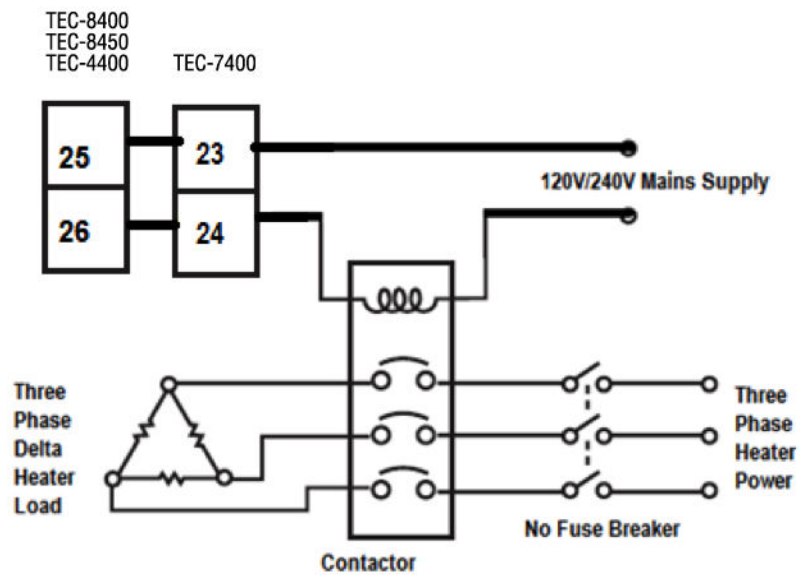

2-41. Alarm 4 Output to Drive Contactor in TEC-4400

## 2.9 Event Input Wiring

The event input can accept a switch (dry contact) or an open collector signal. The event input function (EIFN) is activated as the switch is closed or an open collector (or a logic signal) is pulled down.

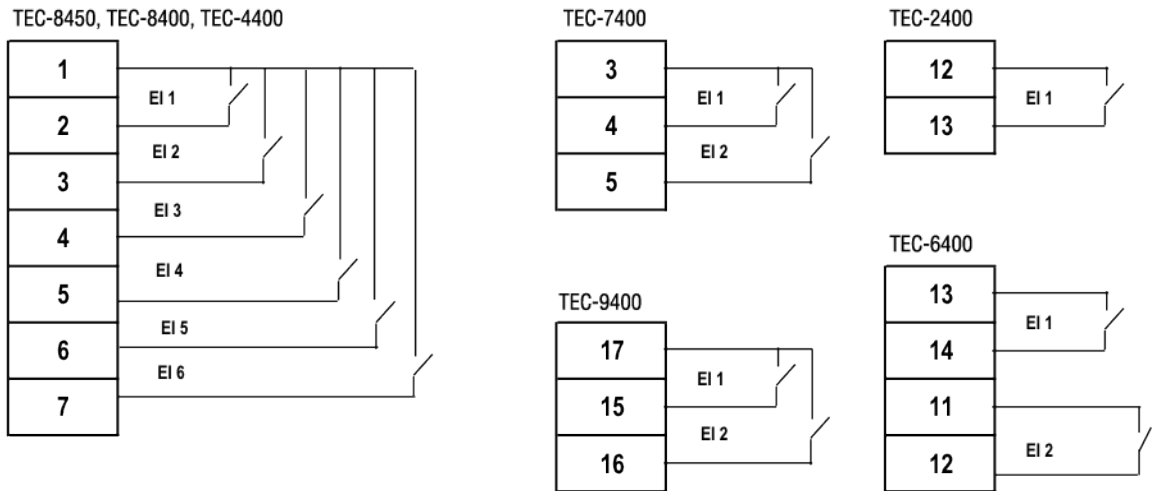

**2-42. Event Input Wiring**

## 2.10 CT Input Wiring

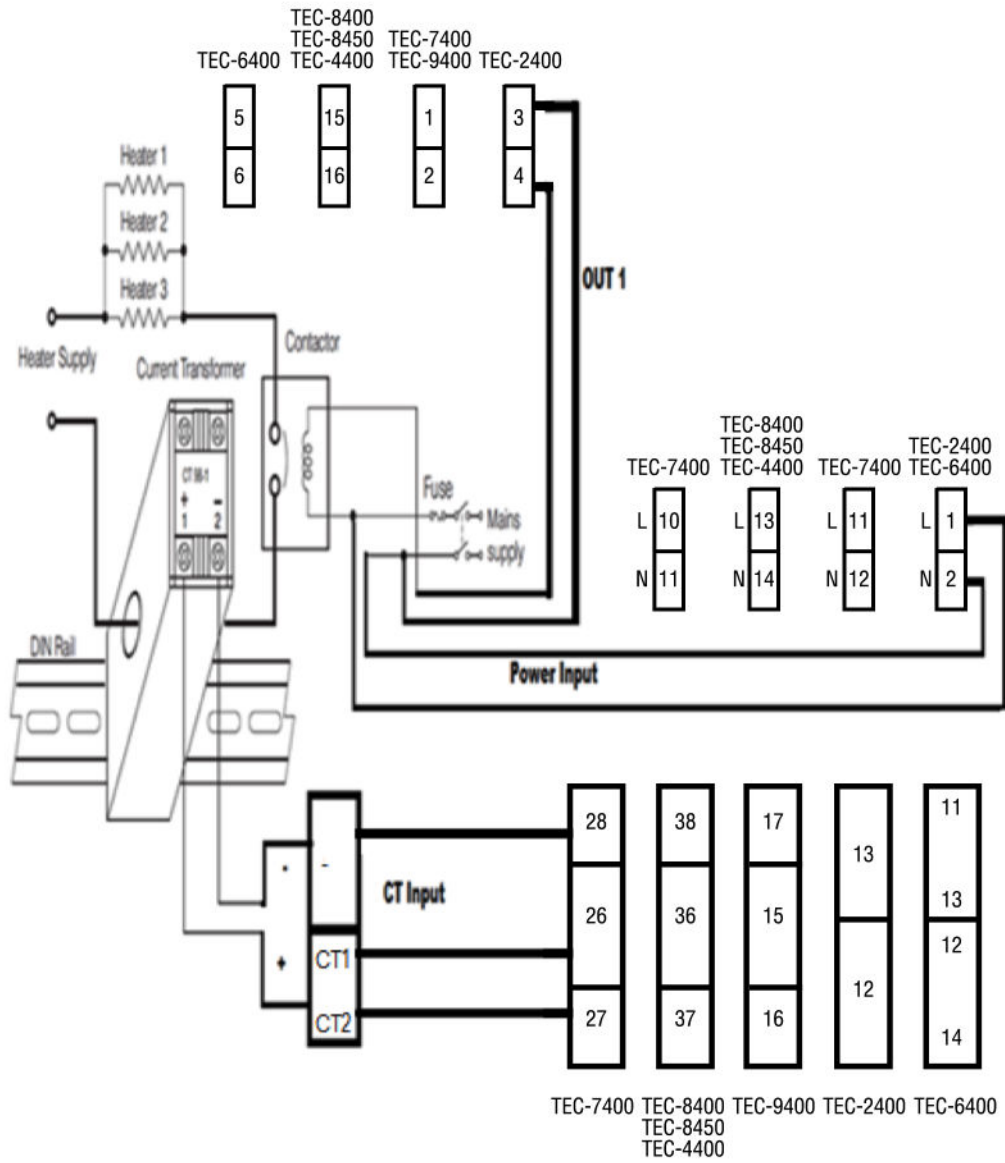

2-43. CT Input Wiring for Single Phase Heater

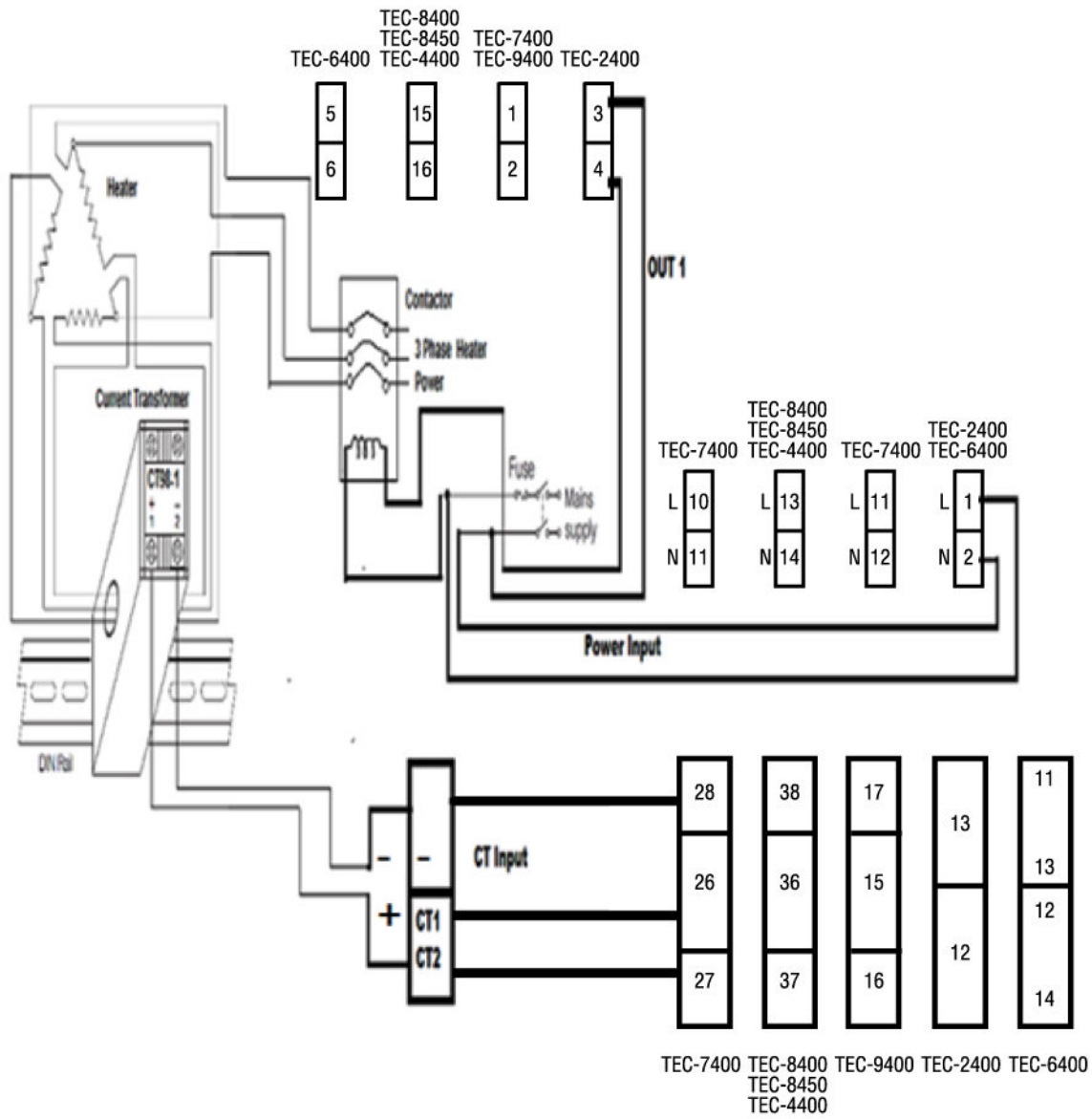

**2-44. CT Input Wiring for 3Phase Heater**

## 2.11 RS-485 Data Communication

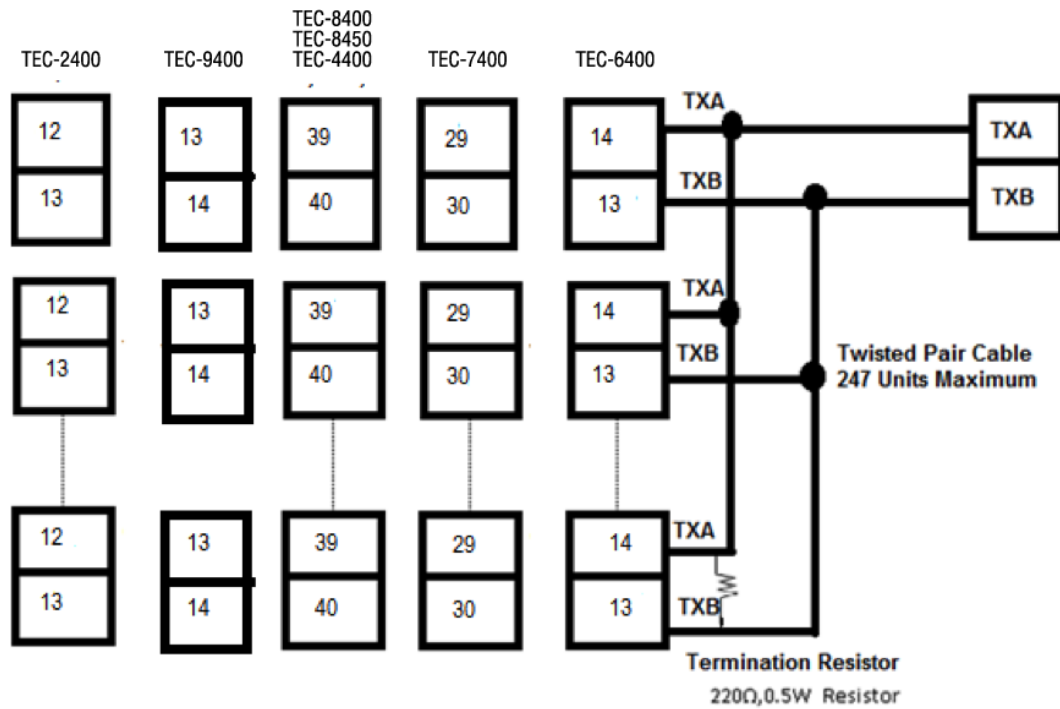

### 2-45.RS-485 Wiring

## 2.12 Retransmission Wiring

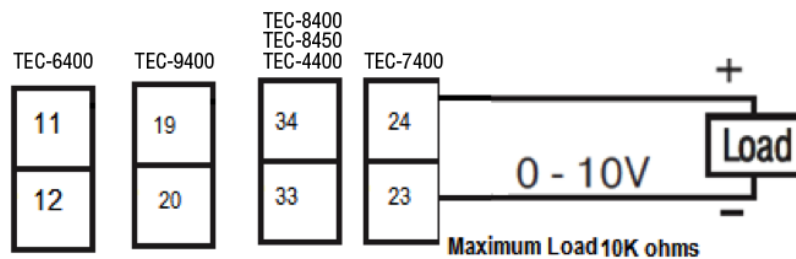
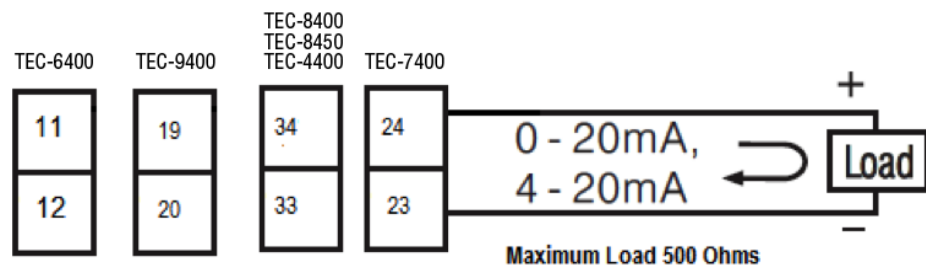

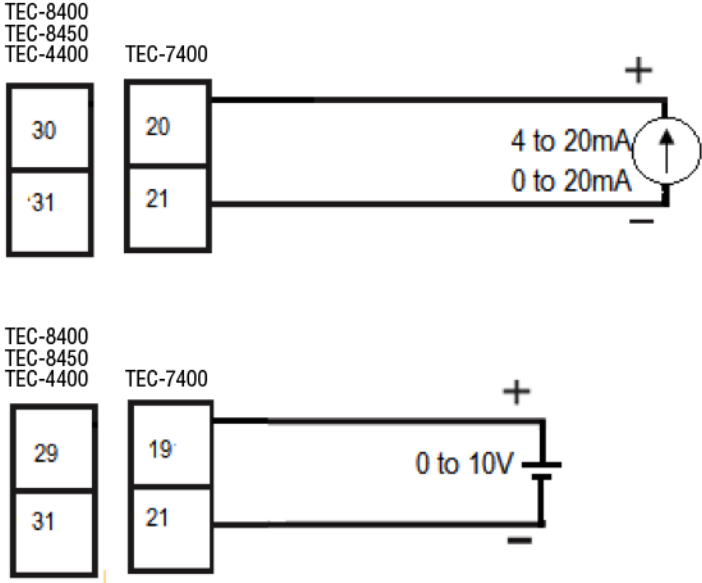

### 2-46. Retransmission Wiring

2.13 Remote Set Point Wiring



2-47.Remote Set Point

### 3 Programming

Press and hold  for 5 seconds, then release to enter the setup menu. Press and release  to cycle through the list of parameters. The upper display indicates the parameter symbol, and the lower display indicates the value of the selected parameter.

#### 3.1 User Security

There are two parameters, PASS (password) and CODE (security code), which will control the lockout program.

CODE Value	PASS Value	Access Rights
0	Any Value	All parameters are changeable
1000	=1000	All parameters are changeable
	≠1000	Only user menu parameters changeable
9999	=9999	All parameters are changeable
	≠9999	Only SP1 to SP7 are changeable
Others	=CODE	All parameters are changeable
	≠CODE	No parameters can be changed

#### 3-1. User Access Rights

#### 3.2 Signal Input

**INPT:** Select the desired sensor type or signal type for the signal input

**Options:** (Thermocouple) J\_TC, K\_TC, T\_TC, E\_TC, B\_TC, R\_TC, S\_TC, N\_TC, L\_TC  
(RTD) PT.DN, PT.JS  
(Linear) 4-20, 0-20, 0-60, 0-1V, 0-5V, 1-5V, 0-10

**UNIT:** Select the desired process unit

**Options:** °C, °F, PU (Process unit). If the unit is neither °C nor °F, then is set to PU.

**DP:** Select the desired resolution (decimal points) for the process value.

**Range:** For Thermocouple and RTD Signal NO.DP, 1-DP and For Linear Signal NO.DP, 1- DP, 2-DP, 3-DP

**INLO:** Select the low scale value for the linear type input.

**INHI:** Select the high scale value for the linear type input.

#### Example of How to use INLO and INHI:

A 4-20mA current loop pressure transducer with range of 0-15 kg/cm is connected to the input.

INPT = 4-20, INLO = 0.00, INHI = 15.00, DP = desired number of decimal points (3 decimals max)

### 3.3 Control Output

There are 4 kinds of control modes can be configured as shown below.

Control Mode	OUT 1	OUT 2	O1HY	O2HY	CPB	DB
Heat Only	REVR	X	Δ	X	X	X
Cool Only	DIRT	X	Δ	X	X	X
Heat PID Cool ON-OFF	REVR	DE.HI	X	O	X	X
Heat PID Cool PID	REVR	COOL	X	X	O	O

#### 3-2.Control Mode

X: Not applicable

O: Adjust to meet process Requirements

Δ: Required if ON-OFF Control is configured

#### 3.3.1 Heat Only ON-OFF Control

Select REVR for OUT1, Set PB to 0. O1HY is used to adjust the hysteresis for ON-OFF control. The output 1 hysteresis (O1HY) setting is only available when PB = 0. The heat only ON-OFF control function is shown below.

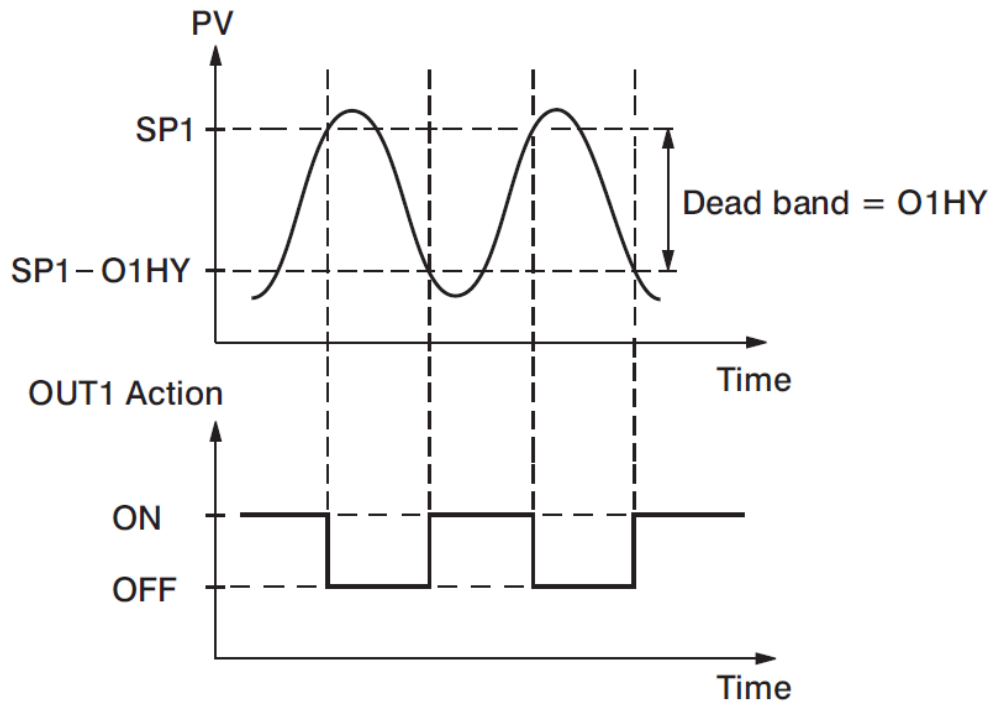

#### 3-1.Heat Only ON-OFF Control

ON-OFF control may cause excessive process oscillations even if the hysteresis is set to the smallest value. If ON-OFF control is used (i.e. PB = 0), TI, TD, CYC1, OFST, CYC2, CPB, DB will no longer be applicable and will be hidden. Auto-Tuning mode and Bumpless transfer are not possible in on/off mode.

### 3.3.2 Heat only P or PD Control

Select REVR for OUT1, set TI = 0, OFST is used to adjust the control offset (manual reset). If PB  $\neq$  0 then O1HY will be hidden.

**OFST Function:** OFST is measured in % with a range of 0 - 100.0 %. When the process is stable, let's say the process value is lower than the set point by 5°F. Let's also say that 20.0 is used for the PB setting. In this example, 5°F is 25% of the proportional band (PB).

By increasing the OFST value by 25%, the control output will adjust itself, and the process value will eventually coincide with the set point.

When using Proportional (P) control (TI = 0), Auto-Tuning will be unavailable. Refer to the "manual tuning" section for the adjustment of PB and TD. Manual reset (OFST) is usually not practical because the load may change from time to time; meaning the OFST setting would need to be constantly adjusted. PID control can avoid this problem.

### 3.3.3 Heat only PID Control

Select REVR for OUT1. PB and TI should not be zero. Perform Auto-Tuning for initial startup. If the control result is not satisfactory, use manual tuning or try Auto-Tuning a second time to improve the control performance.

### 3.3.4 Cool only Control

ON-OFF control, Proportional control, and PID control can be used for cooling control. Set "OUT1" to DIRT (direct action).

**NOTE:** ON-OFF control may result in excessive overshoot and undershoot in the process. Proportional control could result in a deviation of the process value from the set point. It is recommended to use PID control for Heating or Cooling control to produce a stable process value.

### 3.3.5 Other Setup Required

O1TY, CYC1, O2TY, CYC2, O1FT, O2FT O1TY & O2TY are set in accordance with the type of outputs installed. CYC1 & CYC2 are set according to the output 1 type (O1TY) & output 2 type (O2TY). Generally, if SSRD or SSR is used for O1TY, CYC1 is set to a value of 0.5 - 2 seconds. If a Relay is used for O1TY, CYC1 should be set to a value of 10 - 20 seconds. If a linear output is used, CYC1 is not applicable. Similar conditions are applied for CYC2 selection.

The user should use Auto-Tuning program for initial start-up, or they can directly set the appropriate values for PB, TI & TD using the historical records for repeat systems. If the control behavior is still inadequate, then manual tuning may be required to improve control.

### 3.3.6 CPB Programming

The cooling proportional band is measured by a % of PB with a range of 50~300%. Initially, set 100% for CPB and examine the cooling effect. If the cooling action should be enhanced, decrease the CPB value. If the cooling action is too strong, increase the CPB value. The value of CPB is directly proportional to the PB setting. Its value remains unchanged throughout the Auto-Tuning process.

Adjustment of CPB is related to the cooling media used. If air is used as a cooling media, set the CPB to 100(%). If oil is used as the cooling media, set the CPB to 125(%). If water is used as the cooling media, set the CPB to 250(%).

### 3.3.7 DB Programming

Adjustment of DB (Dead band) is dependent on system requirements. If greater dead band is used, then an unwanted cooling action can be avoided, but an excessive overshoot of the set point will occur. If a smaller dead band (DB) is used, then an excessive overshoot can be minimized, but an overlapping of the heating and cooling action will occur. The DB setting is adjustable in the range of -36.0% to 36.0 % of PB.

A negative DB value will have an overlap where both outputs are active. A positive DB value has a dead band area where neither output is active.

### 3.3.8 Output 2 ON-OFF Control (Alarm function)

Output 2 can also be configured as an alarm output. There are 8 kinds of alarm functions and a Dwell timer (dtMR) that can be selected for output 2. They are dtMR (Dwell Timer), dE.HI (deviation high alarm), dE.Lo (deviation low alarm), dB.Hi (Out of band alarm), dB.Lo (In band Alarm), PV.HI (process value high alarm) and PV.LO (process value low alarm), H.bK (Heater Break Alarm), H.St (Heater Short Alarm).

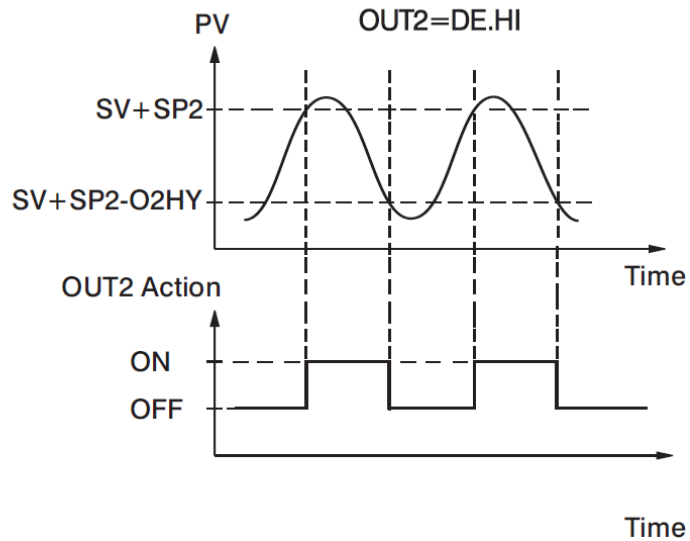

#### 3-2. Output 2 Deviation High Alarm

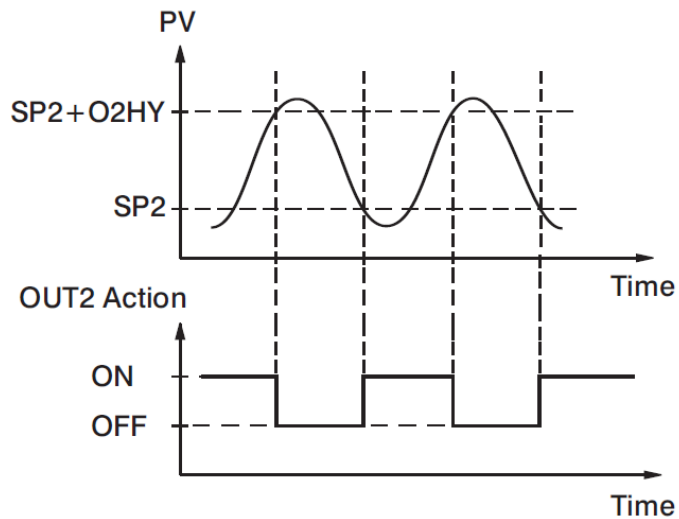

#### 3-3. Output 2 Process Low Alarm

### 3.4 Soft-Start

The controller has a soft start function to limit the control output of output 1 and output 2 for a programmable time (SFT) or up to a programmed threshold value (SFTH). Once either value is reached (time or temperature) the soft start function will terminate and normal PID control begins. This function is useful for effects such as suppressing the heater output during equipment startup.

**Note:** In controllers with the Ramp & Soak Profiler option, if the “PFR” setting is set to something other than “SP1”, then the ramp and soak function will continue with the set parameter during power recovery. If “PFR” is set to “SP1”, then the profile will continue to run with the soft start parameters during power recovery.

There are 5 parameters available for soft start function. They are as below.

1. **Sft:** Soft start time. If the setting “Sft”  $\neq 0$ , the Soft Start function will be enabled. The Soft Start function can be set in the form of Hour:Minute. The range can be set is 00.00 to 99:59.
2. **SFL1:** Soft Start output limit for output 1. It can be set from 0 to 100% (limited by the PL1/PH1 values)
3. **SFL2:** Soft Start output limit for output 2. It can be set from 0 to 100%. (limited by the PL2/PH2 values)
4. **SFtH:** Soft start threshold value. The Soft start will be aborted when the process value is greater than or equal to SFtH.
5. **SFtR:** Soft start time. It will show the remaining time of soft start when it is running.

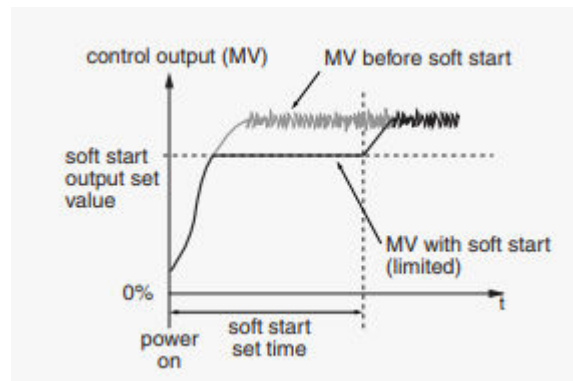

**3-4.Soft Start Function**

## 3.5 Alarm

The controller has up to four alarm outputs depending on the controller model. There are 11 types of alarm functions and one dwell timer that can be selected. There are 4 kinds of alarm modes (A1MD, A2MD, A3MD, and A4MD) available for each alarm function (A1FN, A2FN, A3FN, and A4FN). In addition to the alarm output, output 2 can also be configured as an alarm. But output 2 has only provides 8 different alarm functions or dwell timer available.

### 3.5.1 Alarm Types

There are 11 different types of alarms as listed below that the user can assign to different alarm outputs.

1. **dtMR**: Dwell timer
2. **dE.HI**: Deviation high alarm
3. **dE.Lo**: Deviation low alarm
4. **dB.Hi**: Deviation band out of band alarm
5. **dB.Lo**: Deviation band in band alarm
6. **PV.HI**: Process value high alarm
7. **PV.Lo**: Process value low alarm
8. **H.bK**: Heater break alarm
9. **H.St**: Heater short alarm
10. **E1.C.o**:Event Input 1 Control Alarm Output
11. **E2.C.o**:Event Input 2 Control Alarm Output

1. The **Dwell timer** can be used separately or accompanied with a Ramp. Alarm outputs can be configured as dwell timers by selecting “dtMR” for A1FN (alarm 1 function). If A1FN is set to DTMR, Alarm 1 will act as a dwell timer. Similarly, Alarm 2, Alarm3 or Alarm4 will act as dwell timers if A2FN, A3FN, or A4FN is set to dtMR. When the dwell timer is configured, the parameter “DTMR” is used for dwell time adjustment.

2/3. A deviation alarm alerts the user when the process value deviates too far from the set point. When the process value is higher than  $SV+A1DV$ , a **deviation high alarm (dE.HI)** occurs. The alarm is off when the process value is lower than  $SV+A1DV-A1HY$ . When the process value is lower than  $SV+A1DV$ , a **deviation low alarm (dE.Lo)** occurs. The alarm is off when the process value is higher than  $SV+A1DV+A1HY$ . The trigger level of a deviation alarm is moves with the set point.

4/5. A deviation band alarm presets two trigger levels centered on the set point. The two trigger levels are  $SV+A1DV$  and  $SV-A1DV$ . When the process value is higher than  $(SV+A1DV)$  or lower than  $(SV - A1DV)$ , a **deviation band high alarm (dB.HI)** occurs. When the process value is within the trigger levels, a **deviation band low alarm (dB.Lo)** occurs.

\*In the above descriptions, SV denotes the current set point value for control. This is different from SP1 when the ramp function is used.

6/7. A process alarm can set two absolute trigger levels. When the process value is higher than A1SP, a **process high alarm (PV.HI)** occurs. The alarm is off when the process value is lower than  $A1SP-A1HY$ . When the process value is lower than A1SP, a **process low alarm (PV.Lo)** occurs. The alarm is off when the process is higher than  $A1SP+A1HY$ . A process alarm is independent of the set point.

\*In the above description A1SP and A1HY denote Alarm1 Set point and Alarm1 Hysteresis. The respective Set point and Hysteresis parameters need to be set for other Alarm outputs.

8. Heater break detection is enabled by setting A1FN to HBEN. A **Heater break alarm (H.bK)** alerts the user when the current measured by CT1 in CT1R is lower than HB1T-HBHY, or CT2 in CT2R is lower than HB2T-HBHY. When the current measured by CT1 in CT1R is higher than HB1T-HBHY and CT2 in CT2R is lower than HB2T-HBHY, the heater break alarm will be off. The Heater break alarm will be off when both CT values are in normal range. This Alarm will function when output1 is in ON condition only.

9. The Heater short detection is enabled by setting A1FN to HSEN. A **Heater short alarm (H.St)** alerts the user when the current measured by CT1 in CT1R is higher than HS1T+HSHY, or CT2 in CT2R is higher than HS2T+HSHY. When the current measured by CT1 in CT1R is lower than HS1T+HSHY and CT2 in CT2R is lower than HS2T+HSHY, the heater short alarm will be off. The Heater short alarm will be off when both CT values are in normal range. . This Alarm will function when output1 is in OFF condition only.

\*The Heater break and Heater short alarms will work only with Relay and SSR outputs in output1.

10/11. The Alarm outputs can be controlled by Event input1 and Event input 2 by selecting **Event Input 1 Control Alarm Output (E1.C.o.)** and **Event Input 2 Control Alarm Output (E2.C.o.)** for alarm function A2FN and A3FN .The output will be ON as long as the event input is ON. The output will goes OFF when the input is OFF.

### 3.5.2 Alarm Modes

There are five types of alarm modes available for each alarm function.

1. Normal alarm
2. Latching alarm
3. Holding alarm
4. Latching/ Holding alarm
5. Set point Holding Alarm

#### 3.5.2.1 Normal Alarm: ALMD = NORM

When a normal alarm is selected, the alarm output is de-energized in the non-alarm condition and energized in an alarm condition.

#### 3.5.2.2 Latching Alarm: ALMD = LTCH

If a latching alarm is selected, once the alarm output is energized, it will remain unchanged even if the alarm condition is cleared. The latching alarm can be reset by pressing the "R" key once the alarm condition is no longer present.

#### 3.5.2.3 Holding Alarm: ALMD = HOLD

A holding alarm prevents an alarm condition during power up. This will ignore the alarm condition the first time after initial powering on of the controller. Afterwards, the alarm performs the same function as a normal alarm.

#### 3.5.2.4 Latching / Holding Alarm: ALMD = LT.HO

A latching / holding alarm performs both holding and latching functions. The latching alarm can be reset by pressing the "R" key once the alarm condition is no longer present.

### 3.5.2.5 Set Point Holding Alarm: ALMD = SP.HO

A set point holding alarm prevents an alarm during power up or when changing the set point. The alarm output is de-energized whenever the set point is changed even if it is in an alarm condition. The alarm reverts to a normal alarm once the alarm condition is removed.

### 3.5.3 Alarm Delay

In certain applications during startup, nuisance alarms can occur before the process value reaches the set point. To avoid these kinds of nuisance alarms, a time delay for alarms is available. To enable the time delay for alarms, set the delay time using the A1DL, A2DL, A3DL, and A4DL parameters. These parameters will help to avoid nuisance alarms until the process value reaches set point.

For example, let's say the set point set to 100F. When the process approaches 100F, it could oscillate between 103F and 97F. During this time the Deviation/Process Hi Alarm would be activated and deactivated continuously. To avoid these kind of nuisance alarms, the alarm delay function can be used. It will generate the alarm after the PV is in alarm condition for a pre-determined period of time (AxDL setting). The alarm delay can be configured in minutes and seconds.

### 3.5.4 Alarm Failure Transfer

Alarm Failure transfer is activated if the controller no longer detects an input sensor. The respective Alarm will energize if A1FT-A4FT is set to "ON" and will turn off if A1FT-A4FT is set to "OFF".

## 3.6 User Select Menu Configuration

Conventional controllers are designed with parameters in a fixed order.

If the user needs a friendlier menu operation to suit their application, most conventional controllers do not offer a solution. The LCD Series controllers have the flexibility for the user to select those parameters which are most significant, and put these parameters in an easy access USER menu.

There are eight user friendly parameters from the below list that can be set for user select menu configuration using the SEL1-SEL8 parameters.

- |          |          |
|----------|----------|
| 1. SP2   | 18. A3dV |
| 2. DTMR  | 19. A4HY |
| 3. DISP  | 20. A4SP |
| 4. Pb    | 21. A4dV |
| 5. Td    | 22. PL1L |
| 6. TI    | 23. PL1H |
| 7. o1HY  | 24. PL2L |
| 8. CPb   | 25. PL2H |
| 9. dB    | 26. OFTL |
| 10. A1HY | 27. OFTH |
| 11. A1SP | 28. CALO |
| 12. A1dV | 29. CAHI |
| 13. A2HY | 30. A1DL |
| 14. A2SP | 31. A2DL |
| 15. A2dV | 32. A3DL |
| 16. A3HY | 33. A4DL |
| 17. A3SP |          |

When selecting parameters, all of the above parameters may not be available. The number of visible parameters depends on the configuration of the controller.

**Example:**

OUT2 is set to DE.LO, PB = 100.0, SEL1 is set to INPT, SEL2 is set to UNIT, SEL3 is set to PB, SEL4 is set to TI, SEL5~SEL8 is set to NONE. Now, the USER menu display appears as below.

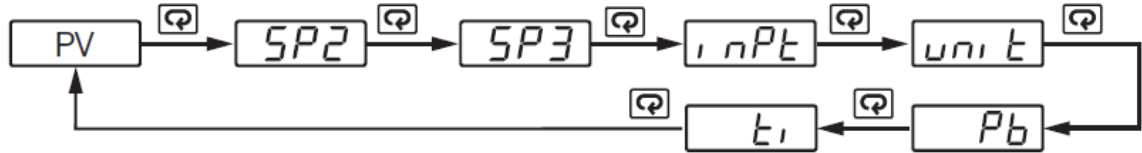

**3-5.Configurable User Menu**

**3.7 Ramp**

The ramping function is performed during power up or any time the set point is changed. Choose “MINR” (ramp in minutes) or “HRR” (ramp in hours) for the “RAMP” setting, and the controller will perform the ramping function. The ramp rate is programmed by adjusting the “RR” setting. The ramping function is disabled whenever the controller enters Failure mode, Manual control mode, Auto-Tuning mode or Calibration mode.

**3.7.1 Ramping Example without Dwell Timer**

Set the “RAMP” setting to “MINR” to ramp in minutes.

Set the ramp rate (RR) to 10.

The starting temperature is 30°C.

The setpoint is initially set to 200°C.

After the process warms up, the user changed the setpoint to 100°C after 30 minutes.

After power up, the process will behave as shown below.

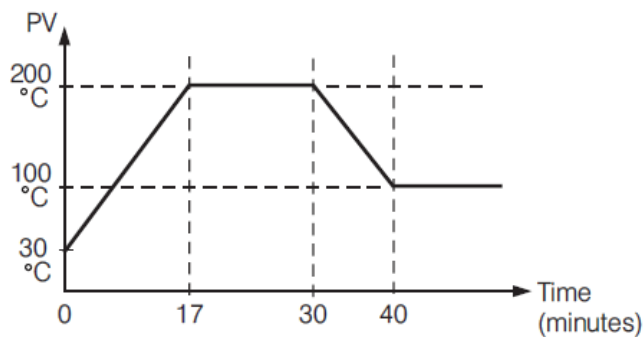

**3-6.Ramp Function**

**Note:** When the ramp function is used, the lower display will show the current ramping value. However it will revert to show the set point value as soon as the up or down key is touched for adjustment. The ramp rate is initiated at power on and/or whenever the Set point is changed. Setting the “RR” setting to zero means no ramping function is used.

### 3.8 Dwell Timer

The Dwell timer can be with or without a Ramp. Alarm outputs can be configured as dwell timers by selecting dtMR for A1FN. If A1FN is set to dtMR, Alarm 1 will act as a dwell timer. Similarly, Alarm 2, Alarm3 and Alarm4 will act as dwell timers if A2FN, A3FN, or A4FN is set to “dtMR”. When the dwell timer is configured, the parameter “DTMR” is used for dwell time adjustment. The dwell time is measured in minutes ranging from 0.0 to 4553.6 minutes. The Timer starts to count as soon as the Process Value (PV) reaches its set point (SV), and triggers an alarm output once the preset time has elapsed. The dwell timer operation is shown in the following diagram.

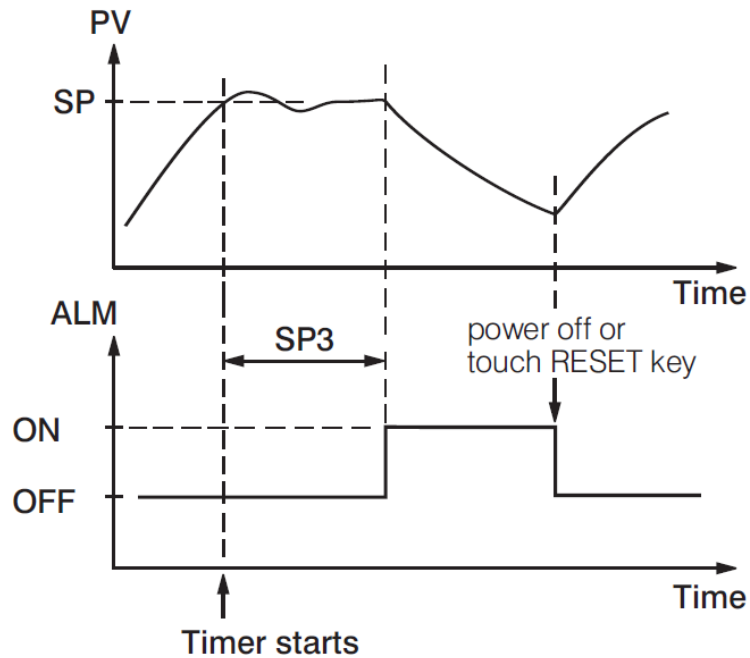

#### 3-7.Dwell Timer

After the timer has finished, the dwell timer can be restarted by pressing the RESET key. The timer stops counting during manual control mode, failure mode, calibration and Auto-Tuning. If the alarm is configured as a dwell timer, A1HY and A1MD are hidden.







### 3.9 User Calibration

Each unit is calibrated in the factory before shipment. The user can still modify the calibration in the field. The basic calibration of the controller is highly stable and set for life. User calibration allows the user to offset the permanent factory calibration in order to:

- ❖ Calibrate the controller to meet a user reference standard.
- ❖ Match the calibration of the controller to that of a particular transducer or sensor input.
- ❖ Calibrate the controller to suit the characteristics of a particular installation.
- ❖ Remove long term drift in the factory set calibration.

There are two parameters: Offset Low (OFTL) and Offset High (OFTH) for adjustment to correct an error in the process value.

There are two parameters for the sensor input. These two signal values are CALO and CAHI. The input signal low and high values are to be entered in the CALO and CAHI parameters respectively.

Refer to [section 1.6](#) for key operation and [section 1.7](#) for the operation flowchart. Press and hold the  key until the setup Menu page is obtained. Then, press and release the  key to navigate to the calibration low parameter OFTL. Send your low signal to the sensor input of the controller, then press and release the  key. If the process value (the upper display) is different from the input signal, the user can use  and  keys to change the OFTL value (the lower display) until the process value is equal to the value the user needs. Press and hold the  key for 5 seconds to complete the low point calibration (the display should blink once). The same procedure is applied for high scale calibration.

As shown below, the two points OFTL and OFTH construct a straight line. For the purpose of accuracy, it is best to calibrate with the two points as far apart as possible. After the user calibration is complete, the input type will be stored in the memory. If the input type is changed, a calibration error will occur and an error code *ERR* is displayed.

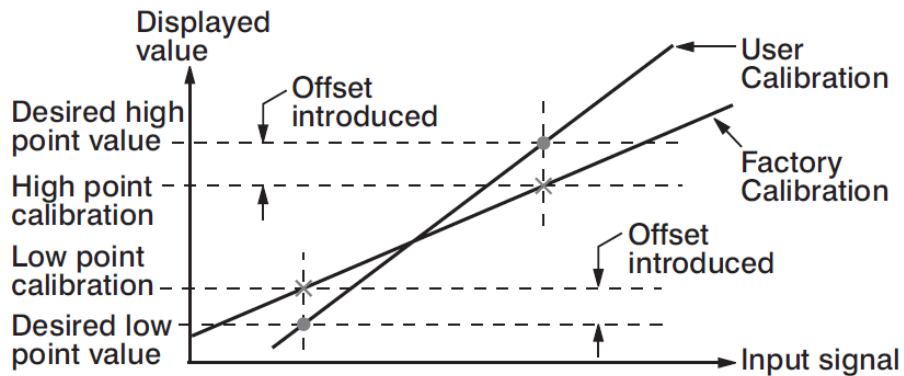

**3-8. Two Point User Calibration**

### 3.10 Digital Filter

In certain applications the process value is too unstable to be read. To improve this, a programmable low pass filter incorporated in the controller can be used. This is a first order filter with a time constant specified by the FILT parameter. A value of 0.5 seconds is used as a factory default. Adjust FILT to change the time constant from 0 to 60 seconds. 0 seconds represents no filter applied to the input signal. The filter is characterized by the following diagram.

#### Note

The Filter is available only for the process value (PV), and is performed for the displayed value only. The controller is designed to use an unfiltered signal for control even when a filter is applied. If a lagged (filtered) signal is used for control; it may produce an unstable process.

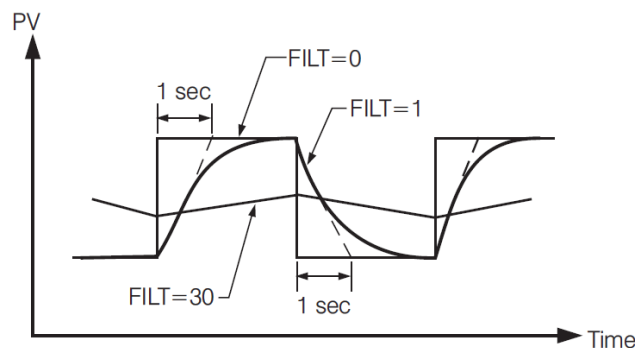

**3-9. Filter Characteristics**

### 3.11 Failure Transfer

The controller will enter failure mode if one of the following conditions occurs:

1. An SBER error occurs due to an input sensor break, an input current below 1mA for 4-20mA, or an input voltage below 0.25V for 1-5 V.
2. An ADER error occurs due to the A-D converter failing.

Output 1 and Output 2 will perform the failure transfer (O1.ft & O2.ft) function as the controller enters failure mode.

#### 3.11.1 Output 1 Failure Transfer

If Output 1 Failure Transfer is activated, it will perform as follows:

1. If output 1 is configured as proportional control (PB≠0), and BPLS is selected for O1FT, then output 1 will perform a Bumpless transfer. After that, the previous average value of the output will be used for controlling output 1.
2. If output 1 is configured as proportional control (PB≠0), and a value of 0 to 100.0 % is set for O1FT, then output 1 will perform failure transfer. After that the value of O1FT will be used for controlling output 1.
3. If output 1 is configured as ON-OFF control (PB=0), then output 1 will transfer to an off state if OFF is set for O1FT, or it will transfer to an on state if ON is set for O1FT.

#### 3.11.2 Output 2 Failure Transfer

If Output 2 Failure Transfer is activated, it will perform as follows:

1. If OUT2 is configured as COOL, and BPLS is selected for O2FT, then output 2 will perform a Bumpless transfer. After that, the previous average value of MV2 will be used for controlling output 2.
2. If OUT2 is configured as COOL, and a value of 0 to 100.0 % is set for O2FT, then output 2 will perform a failure transfer. After that the value of O2FT will be used for controlling output 2.
3. If OUT2 is configured as an alarm function, and OFF is set for O2FT, then output 2 will transfer to an off state, otherwise, output 2 will transfer to an on state if ON is set for O2FT.

#### 3.11.3 Alarm Failure Transfer

An alarm failure transfer is activated as the controller enters failure mode. After that, the alarm output will transfer to the ON or OFF state which is determined by the set value of A1FT, A2FT, A3FT, and A4FT.





### 3.12 Auto-Tuning

 The Auto-Tuning process will be performed at the set point (SP1). The process will oscillate around the set point during the tuning process. Set a set point to a lower value if overshooting beyond the normal process value will cause damage. It is usually best to perform Auto-Tuning at the Set point the machine is expected to be operated at, with the process running normally (i.e. material in the oven, etc.)

Auto-Tuning is generally applied in the following cases:

- ❖ Initial setup for a new process
- ❖ The set point is changed substantially from the previous Set point when Auto-Tuning was performed.
- ❖ The control result is unsatisfactory

### 3.12.1 Auto-Tuning Operation Steps

1. The system is set up to run under real-world conditions.
2. "PB and "TI" settings should not be set to zero.
3. The LOCK parameter should be set to NONE.
4. Set the set point to a normal operating value, or a lower value if overshooting beyond the normal process value will cause damage.
5. Press and hold the  key until  appears on the upper display. Continue to hold the "" key for an additional 3 seconds, else the display will revert to a "User Menu" parameter.
6. Press and hold the  key until the TUNE indicator begins to flash.
7. The Auto-Tuning process has begun.

#### NOTE:

During Auto-Tuning, the output will stay on until the Process Value reaches the setpoint. This is likely to cause the temperature to exceed the setpoint.

Then, the output will remain off until the process value falls below the setpoint.

This will occur at least two times while the controller "learns" how to control your process.

#### Procedures:



Auto-Tuning can be applied either as the process is warming up (Cold Start) or as the process has been in steady state (Warm Start). After the Auto-Tuning process is completed, the TUNE indicator will stop flashing and the unit will revert to PID control by using its new PID values. The PID values obtained are stored in nonvolatile memory.

### 3.12.2 Auto-Tuning Error

If Auto-Tuning fails, an ATER  message will appear on the upper display in any of the following cases.

- ❖ If PB exceeds 9000 ( 9000 PU, 900.0°F or 500.0°C )
- ❖ If TI exceeds 1000 seconds
- ❖ If the set point is changed during the Auto-Tuning process

### 3.12.3 Solution for an Auto-Tuning Error

1. Try Auto-Tuning once again.
2. Avoid changing the set point value during the Auto-Tuning process.
3. Ensure PB and TI are not set to zero.
4. Use manual tuning.
5. Touch RESET  key to reset the  message.

### 3.13 Manual Tuning

In certain applications, using Auto-Tuning may be inadequate for the control requirement, or, the process moves too slowly to Auto-tune accurately.

If this is the case, the user can try manual tuning.

If the control performance by using Auto-Tuning is still unsatisfactory, the following guidelines can be applied for further adjustment of PID values.

ADJUSTMENT SEQUENCE	SYMPTOM	SOLUTION
Proportional Band ( PB )	Slow Response	Decrease PB
	High overshoot or Oscillations	Increase PB
Integral Time ( TI )	Slow Response	Decrease TI
	Instability or Oscillations	Increase TI
Derivative Time ( TD )	Slow Response or Oscillations	Decrease TD
	High Overshoot	Increase TD

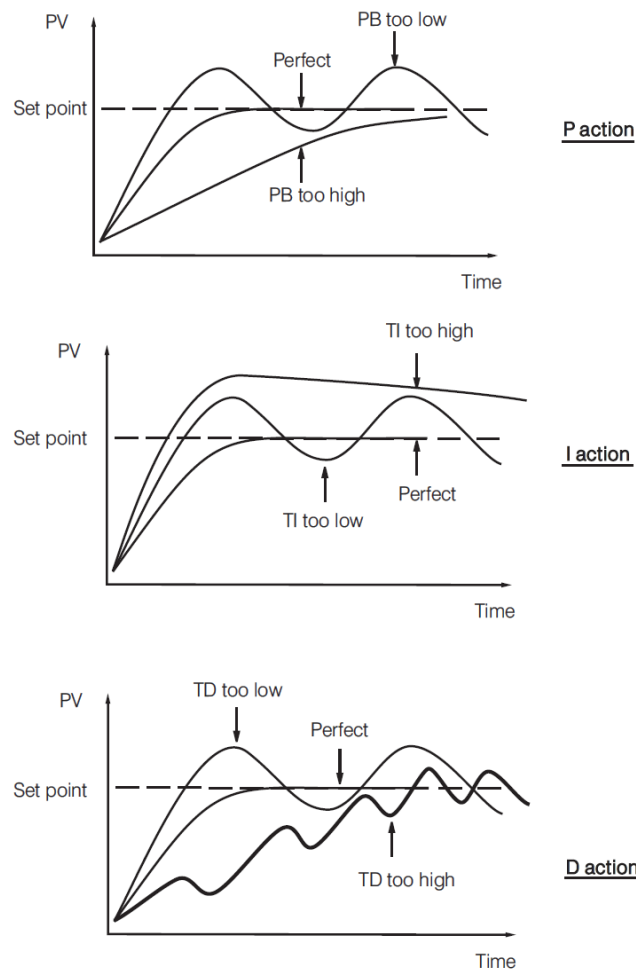

#### 3-3.PID Parameter Adjustment Guide



#### 3-10. Effects of PID Adjustment

### 3.14 Manual Control

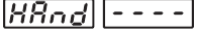
To enable manual control, ensure the LOCK parameter is set to NONE.

Press and hold  until  (Hand Control) appears on the display. Press and hold  until the “MANU” indicator begins to flash. The lower display will show .

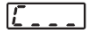
 Indicates the output control variable for output 1, and  indicates the control variable for output 2. The user can use the up-down keys to adjust the percentage values for the heating or cooling output. This % value is based on the CYC1 and CYC2 settings, where the associated output will stay on for the % of time the CYC1 & CYC2 values are set for.

Example: If CYC1 is set to 20seconds, and the controller is set to “H50.0”, the output will be on for 10seconds, then turn off for 10 seconds.





The controller performs open loop control and ignores the input sensor as long as it stays in manual control mode

#### 3.14.1 Exit Manual Control

Pressing the  key will revert the controller to its normal display mode.

### 3.15 Setting Controller to Factory Default

The controller’s parameters can be loaded with default values listed in the [parameter description table](#) . In certain situation it is desirable to retain these values after the parameters values has been changed. The below procedure to be followed to reload the default values.

1. Ensure the LOCK parameter is set to NONE.
2. Press and hold  until  (Hand Control) appears on the display.
3. Press and release the  key to cycle through the manual mode menu to reach “FILE”.
4. Press and hold  for 5 seconds or until the upper display FILE flash for a moment.

### 3.16 Data Communication (Modbus Register Addresses and Programming in a separate manual)

The controllers support RS-485 Modbus RTU protocol for data communication. Using a PC for data communication is the most economical way. The signal is transmitted and received through the PC communication Port .Since a standard PC can't support an RS-485 port, a network adaptor such as an RS232 to RS485 Converter or USB to Serial Converter must be used to convert RS-485 to RS-232 or USB for a PC.. Many RS-485 units (up to 247 units) can be connected to one RS-232 port or USB Port .Therefore a PC with 4 comm. ports can communicate with up to 988 units. It is quite economical.

#### 3.16.1 RS-485 Setup

- ❖ Enters the setup menu.
- ❖ Set individual addresses for units connected to the same port.
- ❖ Set the Baud Rate (BAUD), Data Bit (DATA), Parity Bit (PARI) and Stop Bit (STOP) such that these values are accordant with PC setup conditions.

### 3.17 Retransmission

The controller can output (retransmit) PV or SP via its retransmission terminals RE+ and RE- provided that the retransmission option is ordered. A correct signal type should be selected for option board to meet the retransmission option installed. RELO and REHI are adjusted to specify the low scale and high scale values of retransmission.

### 3.18 Heater Current Monitoring

A current transformer (TEC99998) is required to measure the heater current. The CT input signal conditioner measures the heater current when the heater is powered (output 1 is on), and the current value will remain unchanged the heater is unpowered (output 1 is off). There are 1 or 2 CT inputs that can be connected to the controllers depending on the model. The CT1R & CT2R will indicate the heater current.

Heater break detection is enabled by enabling heater break detection setting HBEN. A **Heater break alarm (H.bK)** alerts the user when the current measured by CT1 in CT1R is lower than HB1T or CT2 in CT2R is lower than HB2T. When the current measured by CT1 in CT1R is higher than HB1T+HBHY and CT2 in CT2R is higher than HB2T+HBHY, the heater break alarm will be off. The Heater break alarm will be off when both CT values are in normal range. The Heater break alarm function will be enabled when OUT1 is in on condition.

Heater short detection is enabled by enabling heater short detection setting HSEN. A **Heater short alarm (H.St)** alerts the user when the current measured by CT1 in CT1R is higher than HS1T or CT2 in CT2R is higher than HS2T. When the current measured by CT1 in CT1R is lower than HS1T-HSHY and CT2 in CT2R is lower than HS2T-HSHY, the heater short alarm will be off. The Heater short alarm will be off when both CT values are in normal range. The Heater short alarm function will be enabled when OUT1 is in off condition.

#### Accessory Required

TEC99998

**Required Setup Parameters** (see “Heater Current Monitoring” above or “Alarm Types” on page 93)

#### Heater Break

1. HBEN
2. HBHY
3. HB1T
4. HB2T

**Heater Short** (see “Heater Current Monitoring” above or “Alarm Types” on page 94)

1. HSEN
2. HSHY
3. HS1T
4. HS2T

### 3.19 Event Input

Depending on the model and options ordered, there are either 1, 2, or 6 Event Inputs available [section 2.8](#) for wiring an event input. The Event input accepts a digital (on/off) type signal such as a switch or a relay contact.

Types of signals that can be used to switch the event input as below.

- ❖ Relay
- ❖ Switch contacts
- ❖ Open collector Pull Low
- ❖ TTL logic level

One of the below functions can be chosen by using **EIFN1 through EIFN6** contained in the setup menu. The same function cannot be set to more than one event input.

#### 3.19.1 Event Input Functions (See below for descriptions)

1. NONE
2. SP2
3. RS.A1
4. RS.A2
5. RS.A3
6. RS.AO
7. CA.LH
8. D.O1
9. D.O2
10. D.O1.2
11. LOCK
12. AU.MA
13. F.tra
14. AL.oN
15. StAR: Run profile as RUN = STAR
16. CoNt: Run profile as RUN = CONT
17. PV: Run profile as RUN = PV
18. Hold: Run profile as RUN = HOLD
19. StoP: Run profile as RUN = STOP

**NONE:** No Event input function. If chosen, the event input function is disabled. The controller will use PB1, TI1 and TD1 for PID control and SP1 (or other values determined by SPMD) for the set point.

**SP2:** If chosen, the SP2 will replace the role of SP1 for control.

**RS.A1:** Reset Alarm 1 as the event input is activated. However, if the alarm 1 condition still exists, alarm 1 will be triggered again when the event input is released.

**RS.A2:** Reset Alarm 2 as the event input is activated. However, if the alarm 2 condition still exists, alarm 2 will be triggered again when the event input is released.

**RS.A3:** Reset Alarm 3 as the event input is activated. However, if the alarm 3 condition still exists, alarm 3 will be triggered again when the event input is released.

**RS.AO:** Reset all Alarms as the event input is activated. However, if the alarm condition still exists, the alarm will be triggered again when the event input is released.

**CA.LH:** Cancel the latched alarm as the event input is activated.

**D.O1:** Disable Output 1 as the event input is activated.

**D.O2:** Disable Output 2 as the event input is activated.

**D.O1.2:** Disable both Output 1 and Output 2.

**Note:** If any of D.O1, D.O2 or D.O1.2 is selected for EIFN, output 1 and/or Output 2 will revert to normal condition as soon as the event input is released.

**LOCK:** All parameters are locked and unable to be changed (Read only) in communication.

**AU.MA:** Switch between Auto-Tuning and manual tuning control mode.

**F.tra:** Switch to Failure Transfer Mode

**AL.oN:** If Alarm 2 or Alarm 3 set to E1.c.o or E2.c.o then EI1 or EI2 will activate Alarm Output Alarm 2 or Alarm 3.

**StAR:** Run profile as RUN=STAR

**CoNt:** Run profile as RUN=CONT

**PV:** Run profile as RUN=PV

**Hold:** Run profile as RUN=HOLD

**StoP:** Run profile as RUN=STOP

### 3.20 Remote Set Point

The Set point will change proportionally with respect to the input given in the remote Set point input terminals. The remote Set point function requires the following parameters to be set.

1. RMSP
2. RINL
3. RINH

### 3.21 Ramp and Soak Program (See descriptions of below settings on following pages)

The new LCD Series controller with profile option can be used in the application where the set point should be changed automatically with the time. It provides 1 program with 16 segment or 2 programs with each 8 segments or 4 programs with each 4 segments. Each segment has both ramp and soak function.

The following parameters are used to configure the controller for ramp and soak programs.

1. PROF
2. RUN
3. RMPU
4. STAR
5. END
6. PFR
7. HBLO
8. HBHI
9. HBT
10. CYC

#### 3.21.1 PROF

Select the required segments to run. There are 8 options available for the user to select the profile segments.

- |                                      |                                    |
|--------------------------------------|------------------------------------|
| 1. <b>NoNE:</b> Not used             | 7. <b>9-16:</b> Uses steps 9 to 16 |
| 2. <b>1--4:</b> Uses steps 1 to 4    | 8. <b>1-16:</b> Uses steps 1 to 16 |
| 3. <b>5--8:</b> Uses steps 5 to 8    |                                    |
| 4. <b>1--8:</b> Uses steps 1 to 8    |                                    |
| 5. <b>9-12:</b> Uses steps 9 to 12   |                                    |
| 6. <b>13-16:</b> Uses steps 13 to 16 |                                    |

## 3.21.2 RUN

Select the profile run mode. There are 5 modes available in the controller.

1. **StAR**: Start to run profile
2. **CoNt**: Continue run profile
3. **PV**: Continue run profile from current PV
4. **Hold**: Hold profile
5. **SToP**: Stop profile

### 3.21.2.1 StAR

The Profile starts to run from the first segment in the selected profile. In run mode, the profiler varies the set point according to the stored profile values.

### 3.21.2.2 CoNt

The Profile starts to run from the segment where it stopped.

### 3.21.2.3 PV

The Profile starts to run from the segment where it stopped with current process value.

### 3.21.2.4 Hold

In hold mode, the profile is frozen at its current point. In this state the user can make temporary changes to any profile parameter (for example, a target set point, a dwell time or the time remaining in the current segment). Such changes will only remain effective until the profile is reset and run again and when they will be overwritten by the stored profile values.

### 3.21.2.5 StoP

In stop mode the Profile is stopped.

## 3.21.3 RMPU

Select the Ramp and Soak time units to be used. The options available for selection are Hour Minutes (HH:MM) and Minute Seconds (MM:SS)

## 3.21.4 STAR

The Set point value of the profile start. The options available for selection is Process value (PV) and controller Set point (SP1).

The normal method is to start the profile from the process value, because this will produce a smooth and Bumpless start to the process. However, to guarantee the time period of the first segment, the STAR set to SP1 for the start point

## 3.21.5 END

The Set point value at the end of profile. The options available for end Set point is Controller Set point (SP1).

### 3.21.5.1 SP1

The Profile ends with controller Set point SP1.

### 3.21.6 PFR

If power is lost and then restored, while a profile is running, the behaviour of the profile is determined by the setting of the parameter “PFR” “power fail recovery in profile configuration. The options available for PFR are **CONT**, **PV**, **SP1** and **OFF**.

#### 3.21.6.1 CONT

If **CONT** is selected, then when power is restored the profile continues from where it was interrupted when power was lost. The parameters such as set point value (SV), time remaining (DTMR) and cycle remaining (CYCR) will be restored to their power-down values. For applications that need to bring the process value to the set point value as soon as possible, this is the best choice. The two diagrams below illustrate the respective responses.

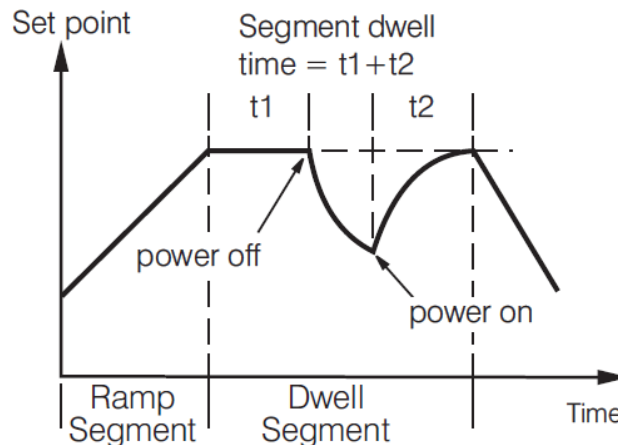

**3-11. Power failure recovery from profile at Dwell segment**

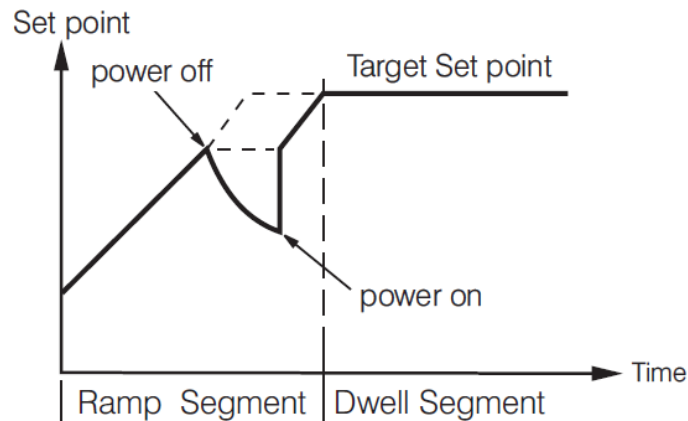

**3-12. Power failure recovery from profile at Ramp segment**

### 3.21.6.2 PV

If "PV" is selected then when power is restored the set point starts at the current process value, and then runs to the target set point of the active segment. This choice provides a smoother recovery. The two diagrams below illustrate the respective responses

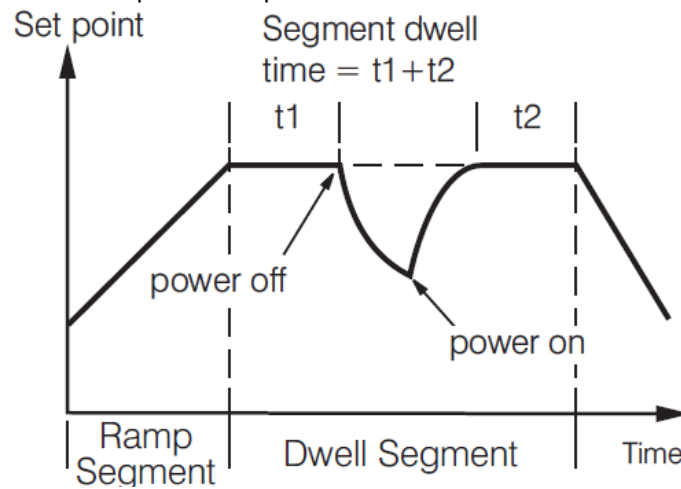

**3-13. Power failure recovery from PV during a Dwell segment**

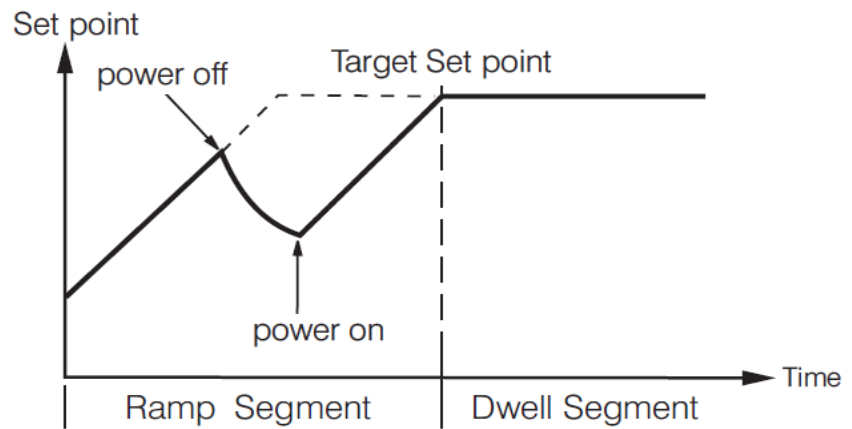

**3-14. Power failure recovery from PV at Ramp Segment**

### 3.21.6.3 SP1

If SP1 If is selected, then when power is restored, the profile is disabled and the controller enters static mode. "SP1" is used for the control set point.

### 3.21.6.4 OFF

If OFF is selected, then when power is restored, the profiler is disabled and it enters OFF mode, all the control outputs as well as alarms and events are off.

### 3.21.7 Holdback

As the set point ramps up or down (or dwells), the measured value may lag behind or deviate from the set point by an undesirable amount. "Holdback" is available to freeze the profile at its current state. The action of Holdback is the same as a deviation alarm. Holdback has three parameters.

1. **HBLO**: Holdback low band
2. **HBHI**: Holdback high band
3. **HBT**: Holdback wait time

If the error from the set point exceeds the set **holdback high band (HBHI)** or lags than the set **holdback low band (HBLO)**, then the holdback will automatically freeze the profile at its current point and the holdback timer begins to count. When the value of holdback timer exceeds the value of **holdback wait time (HBT)**, Holdback indicator HdbK will flash and an error code **HBER** will be displayed.

### 3.21.8 CYCL

The number of cycles to be repeated for the selected profile to be configured by this parameter.

### 3.21.9 Running, Holding and Stopping a Profile

The profile has been start by selecting STAR in the lower display by using   keys. After selecting **STAR** press    keys simultaneously for 1 second to start the profile. The same procedure is applied for Holding and stopping profile. To holding the profile select **HOLD** and stop the profile select **STOP** in the lower display

### 3.21.10 Viewing and Modifying the Profile Progress

The Profile in progress can be monitored and modified by using the four parameters as below.

1. **CYCR**: The remaining cycles of the profile
2. **STEP**: The running step of the profile
3. **TIMR**: The time remaining to complete the current step of the profile
4. **STAT**: The current state of the profile.

### 3.21.11 Configuring the Profile

The profile has been configured by using the following parameters. There are 16 segments available for configuration. The 16 segments can be used as a single profile, or two profiles with 8 segments each, or four profiles with 4 segments each. This selection can be done by using the "**PROF**" parameter selection.

### **3.21.11.1 Profile Segment Parameters**

Each profile segment has the following parameters.

1. Target Set Point(TSP)
2. Ramp Time(RPT)
3. Soak Time(SKT)

#### **3.21.11.1.1 Target Set point**

The target Set point of the segment can be configured by the parameters TSP1 through TSP16

#### **3.21.11.1.2 Ramp Time**

The Ramp time of the segment can be configured by the parameters RPT1 through RPT16.

#### **3.21.11.1.3 Soak Time**

The Soak time of the segment can be configured by the parameters SKT1 through SKT16.

## 4 Applications

### 4.1 Heat Only Control with Dwell Timer

An oven is designed to dry the products at 150°C for 30 minutes, and then stay unpowered for another batch. A new Tempco LCD series controller equipped with a dwell timer is used for this purpose. The system diagram is shown as below.

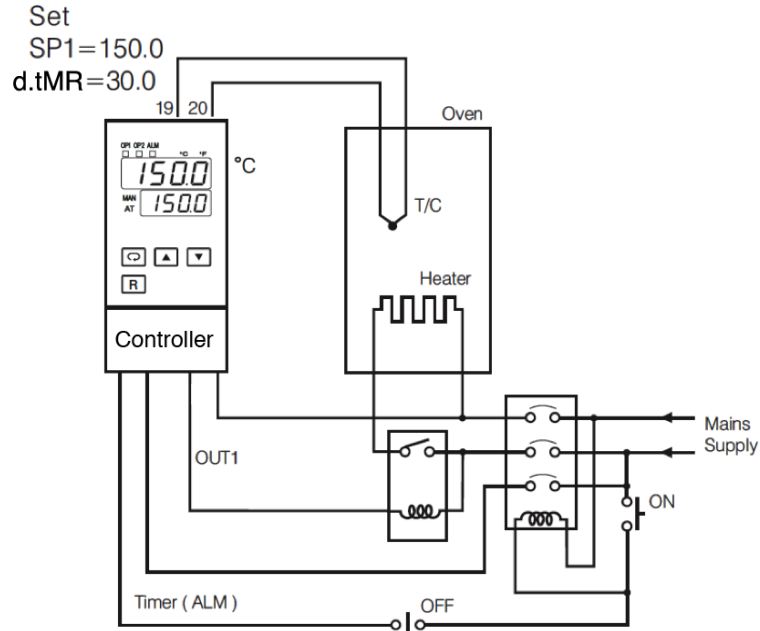

#### **4-1.Heat Only Control with Dwell Timer**

To achieve this function set the following parameters in the setup menu.

INPT=K\_TC  
UNIT=° C  
DP=1\_DP  
OUT1=REVR  
O1TY=RELY  
CYC1=18.0  
O1FT=BPLS  
ALFN=dtMR  
ALFT=ON

Auto-Tuning is performed at 150°C for a new oven.

## 4.2 Cool Only Control

A Tempco LCD Series Controller is used to control a refrigerator at a temperature below 0°C. Since the required temperature is lower than the ambient temperature, a cooling action is required. Hence, select DIRT for OUT1. Since output 1 is used to drive a magnetic contactor, O1TY is set to RELY. A small temperature oscillation is tolerable; therefore use ON-OFF control to reduce the over-all wear and cost. To achieve ON-OFF control, PB is set to zero and O1HY is set to 0.1°C.

### Setup Summary:

INPT=PT.DN

UNIT= °C

DP=1-DP

OUT1=DIRT

O1TY=RELY

### User Menu:

PB = 0 (°C)

O1HY=0.1 (°C)

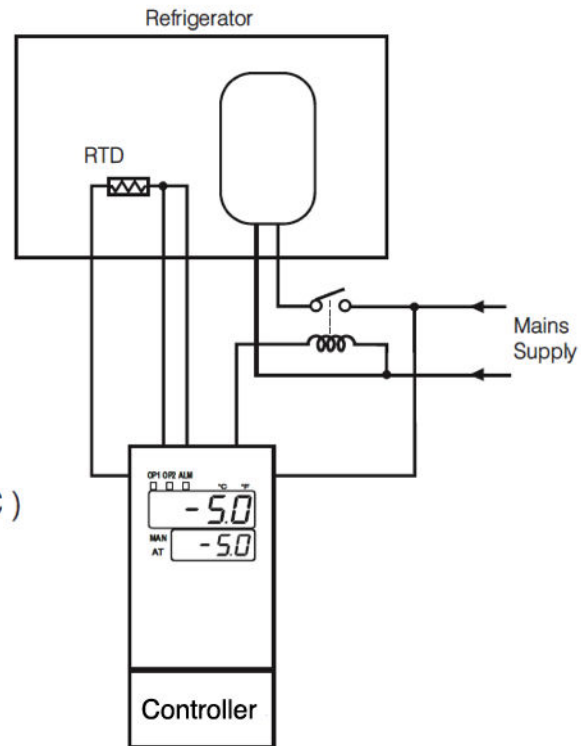

### 4-2.Cooling Control

### 4.3 Heat and Cool Control

An injection mold is required to be controlled at 120°C to ensure a consistent quality of the parts. An oil pipe is buried in the mold. Since plastic is injected at a higher temperature (e.g. 250°C), the circulation oil needs to be cooled as its temperature rises. Here is an example.

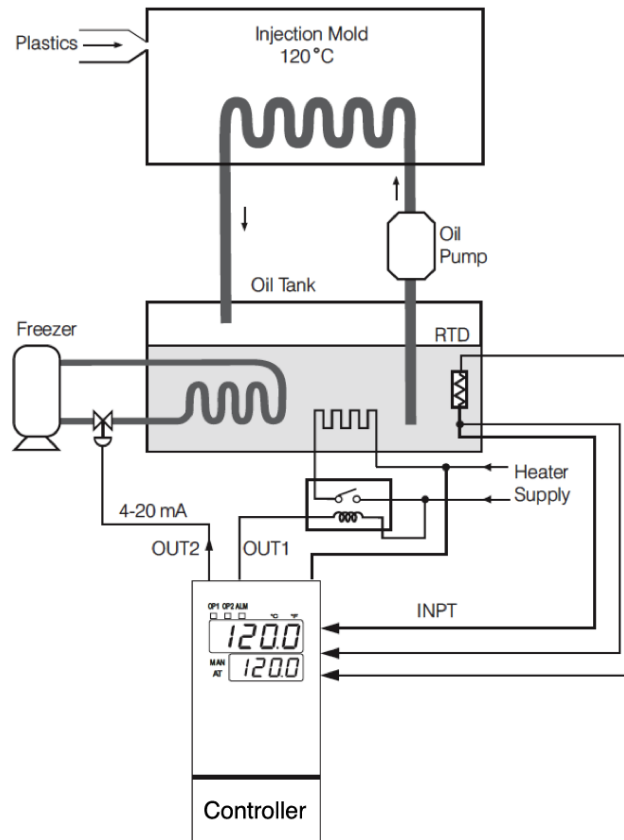

#### 4-3.Heat Cool Control

The PID Heat-Cool control is used for the above example. To achieve this, set the following parameters in the Setup Menu

INPT=PT.DN  
UNIT=° C  
DP= 1-DP  
OUT1=REVR  
O1TY=RELY  
CYC1=18.0 (sec.)  
O1FT=BPLS  
OUT2=COOL  
O2TY=4-20  
O2FT=BPLS

(continued on next page)

Adjust SV at 120.0° C, CPB at 125 (%) and DB at -4.0 (%).

Apply Auto-Tuning at 120°C for a new system to get an optimal PID values.

Adjustment of CPB is related to the cooling media used. If water is used as cooling media instead of oil, the CPB is set to 250 (%). If air is used as cooling media instead of oil, the CPB is set to 100 (%). Adjustment of DB is dependent on the system requirements.

A more positive value of DB will prevent an unwanted cooling action, but will increase the temperature overshoot, while more negative value of DB will achieve less temperature overshoot, but will increase unwanted cooling action.

## **4.4 Ramp & Dwell**

### **4.4.1 Temperature Cycling Chamber**

A chamber is used to test the temperature cycling effect on personal computers. An external cycle timer is used to control the event input for switching the set point. The products under test are required to stay at 60°C for 1 hour and -10°C for 30 minutes. The transition interval between high-low temperatures is required to be 5 minutes. Make the following setup.

E1FN=SP2

A1FN=DTMR

OUT1=REVR, Relay Output

OUT2=COOL, 4-20mA Output

RAMP=MINR

UNIT=°C

The circuit diagram and its temperature profile are shown on the following page.

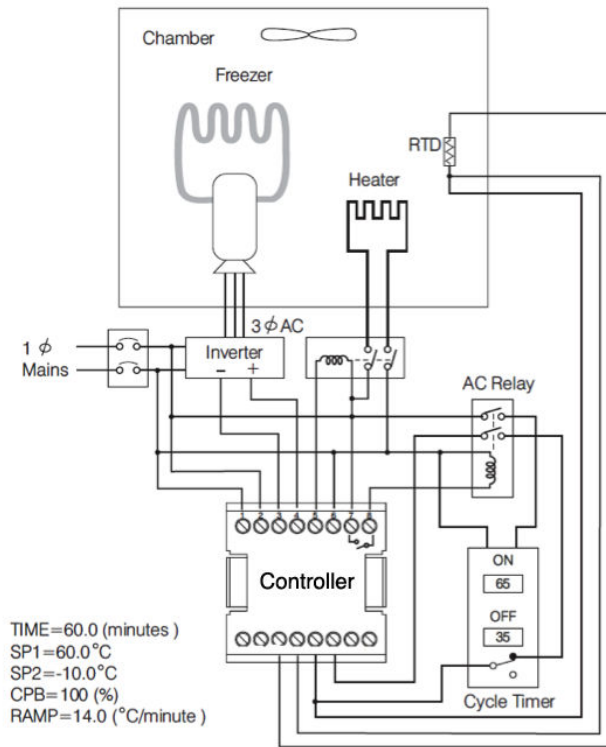

#### 4-4.Ramp & Dwell Temperature Cycling Chamber

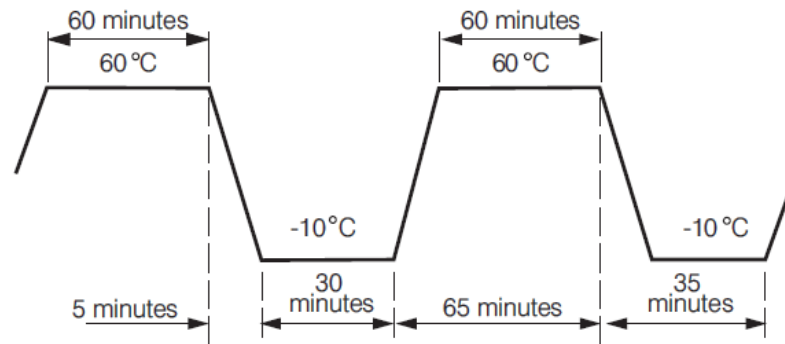

#### 4-5.Temperature Profile for Temperature Cycling Chamber

An LCD Series Controller provides a 4-20 mA signal to control the speed of an Inverter. SP2 is chosen for EIFN for the purpose of accomplishing a dual PID control.

#### 4.4.2 Programmable Bread Baking Oven

Bread is baked in batches. A ramp is incorporated to control the thermal gradient to suit for making the bread. A dwell timer is used to shut off the oven power and announce to the baker. The system is configured as shown in the following diagram.

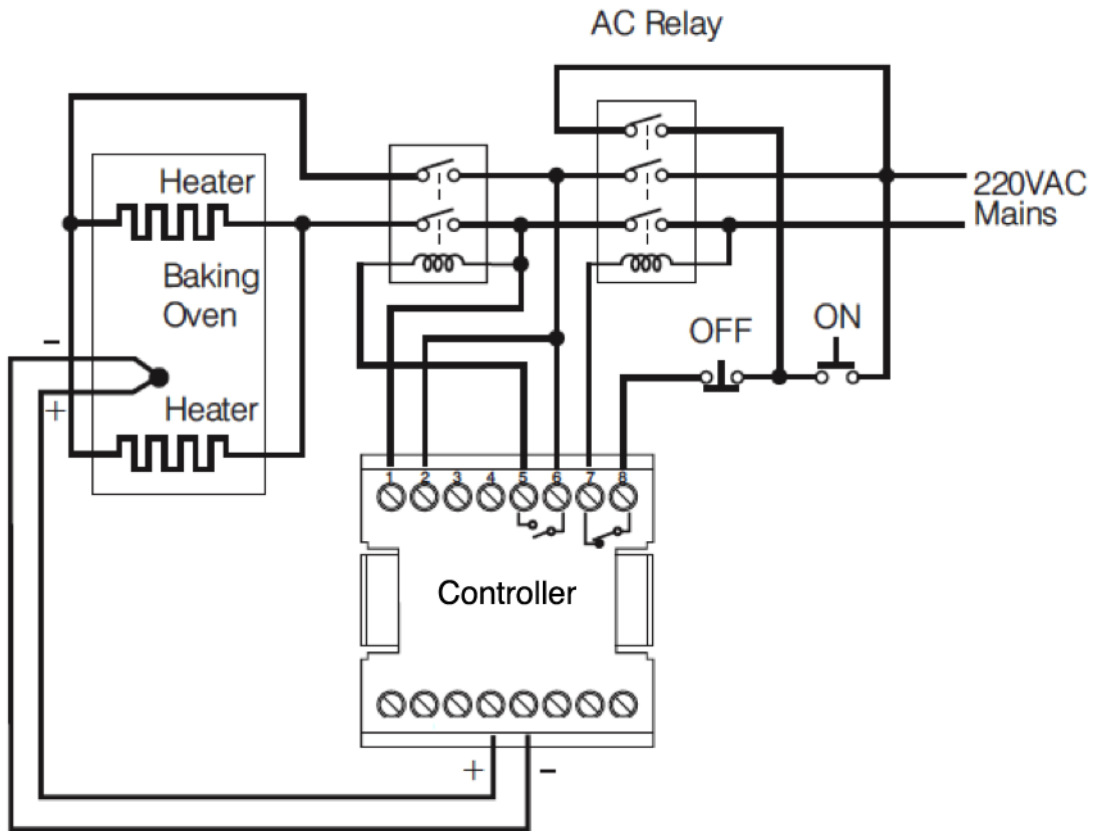

#### 4-6. Bread Baking Oven

Order a form A relay for Alarm 1. Push the ON switch to start a batch. The temperature will rise with a ramp rate determined by the RAMP value. Bread is baked at the set point temperature for a pre-determined time which is determined by setting the "DTMR" value, and then the power is shut off.

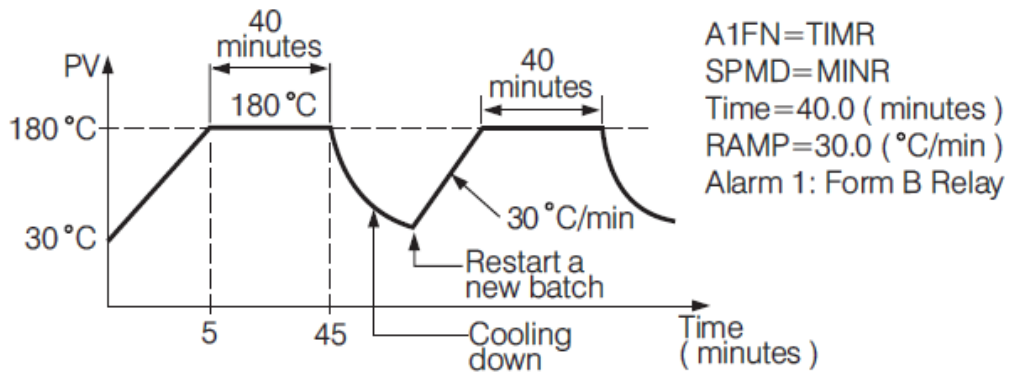

#### 4-7. Temperature Profile of Baking Oven

## 4.5 Remote Set Point

An on-line multiple zone oven is used to dry paint. Since heat demand varies at different positions in the production line, multiple zones with individual controls should be used to ensure a consistent temperature profile. If the user uses an LCD Series Controller with a retransmission output for the primary controller and retransmits its set point to the remote Set point input of the secondary controllers, each zone will be synchronized with the same temperature. Here is an example.

**Figure 5.12 Remote Set Point Application**

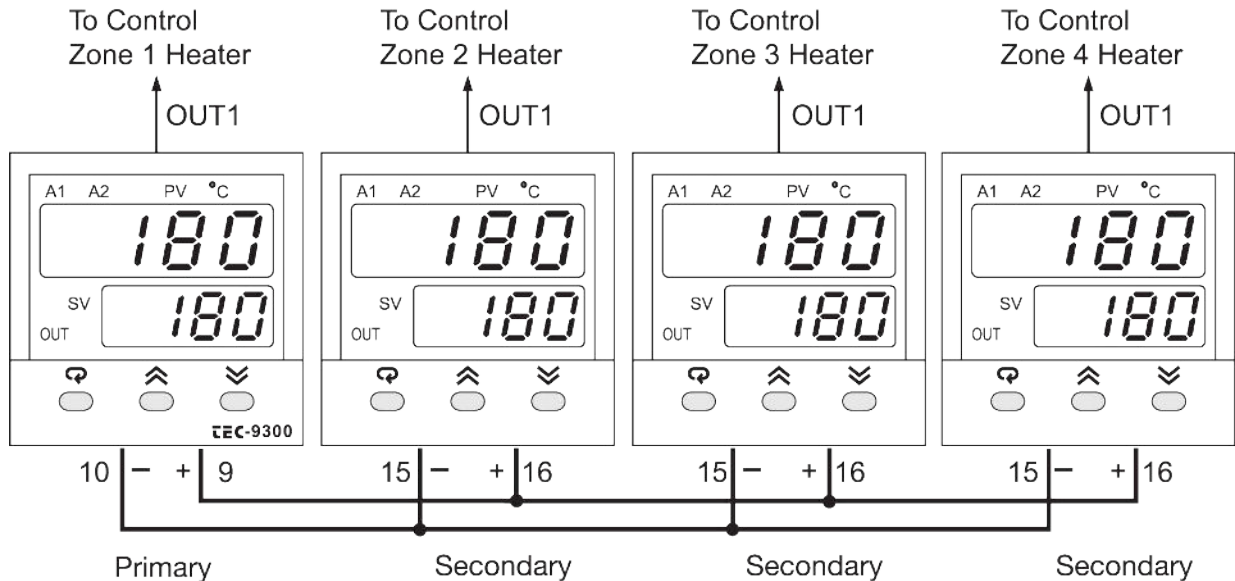

### **4-8.Remote Set point Application**

Set the following parameters in the setup menu.

For primary unit  
FUNC= FULL  
OFS3=3(0-5V)  
RETY=RE.SP  
RELO= 0°C  
REHI = 300°C

For secondary units  
FUNC= FULL  
OFS1 or OFS2 or OFS3 has to be set for a proper retransmission option.  
RMSP=2(0 – 5V)  
RINL=0°C  
RINH=300°C

If a voltage signal (such as in the above example) is sent to secondary units, the secondary inputs must be connected in parallel. If a current signal (e.g. 4-20 mA) is sent to secondary units, the secondary inputs must be connected in series. Current retransmission is used widely since it can transmit to a longer distance without voltage drop.

**Note:** REHI and RINH should be set with values higher than the set point range used.

## 4.6 Retransmission Application

An air-conditioned room uses controllers to control its temperature and humidity. The temperature and humidity are required to be recorded on a recorder. The ranges of interest for these two quantities are: 20°C to 30°C and 40% RH to 60% RH. The recorder inputs accept 0 - 5 V signal.

To achieve this, set the following parameters in the Setup menu.

### UNIT 1

FUNC= FULL

OFS3=3(0-5V)

RETY=RE.PV

RELO= 0°C

REHI = 300°C

UNIT=°C

### UNIT 2

FUNC= FULL

OFS3=3(0-5V)

RETY=RE.PV

RELO= 0°C

REHI = 300°C

INPT= 0 - 1 V (According to humidity sensor)

UNIT= PU

SP1L and SP1H are used to limit the adjustment range of the set point.

## 4.7 Ramp & Soak Profile in Heat Treatment Chamber

A heat treatment chamber needs to change temperature based on certain time intervals. The process requires a rapid increase of temperature as it is heated and a rapid decrease of temperature as it is cooled. In order to achieve a rapid increase of temperature, an additional heater is turned on at higher range of temperature. A cooling fan is turned on to accelerate the cooling rate as the temperature falls fast. An alarm is required to announce to the operator that the procedure is finished.

Output 1 is used to drive the main heater, output 2 is used to drive the cooling fan

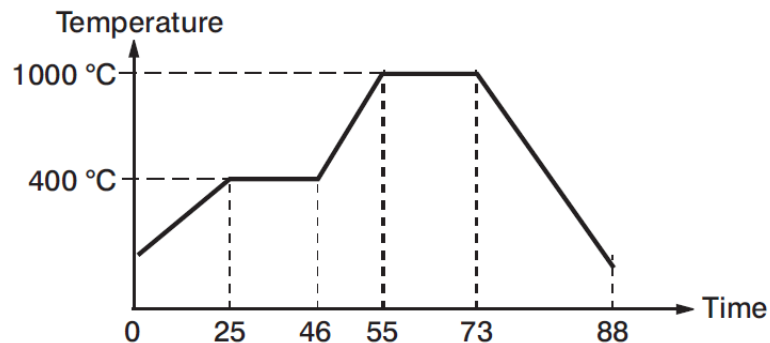

**4-9. Temperature Profile of the Heat Treatment Chamber**

The temperature profile shown in the above figure can be achieved by using the parameters shown on the following page.

PROF=1-4  
 RUN=StAR  
 RMPU=MM:SS  
 STAR=Pv  
 END=OFF  
 PFR=CONT  
 CYCL=1

TSP1=400°C  
 RPT1=25:00  
 SKT1=00:00  
 TSP2=400°C  
 RPT2=00:00  
 SKT2=21:00  
 TSP3=1000°C  
 RPT3=09:00  
 SKT3=00:00  
 TSP4=1000°C  
 RPT4=00:00  
 SKT4=18:00

INPT=K\_TC  
 UNIT=°C  
 DP=No dP  
 OUT1=REVR  
 CYC1=18  
 OUT2=COOL

#### 4.8 Parameter Availability Table

Register Address	Parameter Notation	TEC-2400	TEC-9400	TEC-8400	TEC-8450	TEC-7400	TEC-4400	TEC-6400	Existence Conditions
0	SP1	V	V	V	V	V	V	V	Exists unconditionally
1	SP2	V	V	V	V	V	V	V	<b>TEC-4400/TEC-8400/TEC-8450/TEC-7400:</b> Exists if E1FN is set to SP2 <b>TEC-9400/TEC-2400/TEC-6400:</b> Exists if E1FN is exist and E1FN is set to SP2
2	SP3		V	V	V	V	V	V	<b>TEC-4400/TEC-8400/TEC-8450/TEC-7400:</b> Exists if E2FN is set to SP3 <b>TEC-9400/TEC-6400:</b> Exists if E2FN is exist and E2FN is set to SP3
3	SP4			V	V		V		Exists if E3FN is set to SP4
4	SP5			V	V		V		Exists if E4FN is set to SP5
5	SP6			V	V		V		Exists if E5FN is set to SP6

Register Address	Parameter Notation	TEC-2400	TEC-9400	TEC-8400	TEC-8450	TEC-7400	TEC-4400	TEC-6400	Existence Conditions
6	SP7			V	V		V		Exists if E6FN is set to SP7
7	DTMR	V	V	V	V	V	V	V	<b>TEC-4400/TEC-8400/TEC-8450:</b> Exists if A1FN is set to DTMR or A2FN is set to DTMR or A3FN is set to DTMR or A4FN is set to DTMR <b>TEC-7400:</b> Exists if A1FN is set to DTMR or A2FN is set to DTMR or A3FN is set to DTMR or OFS3 is set to AL4 and A4FN is set to DTMR <b>TEC-9400:</b> Exists if A1FN is set to DTMR or A2FN is set to DTMR or OFS3 is set to ALM3 and A3FN is set to DTMR <b>TEC-2400/TEC-6400:</b> Exists if A1FN is set to DTMR or A2FN is set to DTMR
8	INPT	V	V	V	V	V	V	V	Exists unconditionally
9	UNIT	V	V	V	V	V	V	V	Exists unconditionally
10	DP	V	V	V	V	V	V	V	Exists unconditionally
11	INLO	V	V	V	V	V	V	V	Exists if INPT is set to 4-20, 0-20, 0-5V, 1-5V or 0-10
12	INH1	V	V	V	V	V	V	V	
13	SP1L	V	V	V	V	V	V	V	Exists unconditionally
14	SP1H	V	V	V	V	V	V	V	Exists unconditionally
15	FILT	V	V	V	V	V	V	V	Exists unconditionally
16	DISP			V	V	V	V		Exists unconditionally
17	PB	V	V	V	V	V	V	V	Exists unconditionally
18	TI	V	V	V	V	V	V	V	Exists if PB1 ≠ 0
19	TD	V	V	V	V	V	V	V	
20	OUT1	V	V	V	V	V	V	V	Exists unconditionally
21	O1TY	V	V	V	V	V	V	V	Exists unconditionally
22	O1FT	V	V	V	V	V	V	V	Exists unconditionally
23	O1HY	V	V	V	V	V	V	V	Exists if PB1 = 0
24	CYC1	V	V	V	V	V	V	V	Exists if PB1 ≠ 0
25	OFST	V	V	V	V	V	V	V	Exists if PB1 ≠ 0 and TI = 0
26	RAMP	V	V	V	V	V	V	V	Exists unconditionally
27	RR	V	V	V	V	V	V	V	Exists if RAMP is set to MINR or HRR
28	OUT2	V	V	V	V	V	V	V	Exists unconditionally
29	O2TY	V	V	V	V	V	V	V	Exists if OUT2 is set to COOL or AL1 or RAL1
30	O2FT	V	V	V	V	V	V	V	
31	CYC2	V	V	V	V	V	V	V	Exists if OUT2 is set to COOL
32	CPB	V	V	V	V	V	V	V	
33	DB	V	V	V	V	V	V	V	
34	A1FN	V	V	V	V	V	V	V	Exists if OUT2 is set to AL1 or RAL1

Register Address	Parameter Notation	TEC-2400	TEC-9400	TEC-8400	TEC-8450	TEC-7400	TEC-4400	TEC-6400	Existence Conditions
35	A1MD	V	V	V	V	V	V	V	Exists if OUT2 is set to AL1 or RAL1 and A1FN is set to DEHI, DELO, DBHI, DBLO, PVHI, PVLO, H.BK or H.ST
36	A1HY	V	V	V	V	V	V	V	Exists if OUT2 is set to AL1 or RAL1 and A1FN is set to DEHI,DELO,DBHI,DBLO,PVHI, or PVLO
37	A1FT	V	V	V	V	V	V	V	Exists if OUT2 is set to AL1 or RAL1 and A1FN is set to DTMR,DEHI,DELO,DBHI,DBLO,PVHI, or PVLO
38	A1SP	V	V	V	V	V	V	V	Exists if OUT2 is set to AL1 or RAL1 and A1FN is set to PVHI, or PVLO
39	A1DV	V	V	V	V	V	V	V	Exists if OUT2 is set to AL1 or RAL1 and A1FN is set to DEHI,DELO,DBHI,DBLO
40	A2OT	V	V	V	V	V	V	V	<b>TEC-4400/TEC-8400/TEC-8450/TEC-7400/TEC-9400:</b> Exists unconditionally <b>TEC-2400/TEC-6400:</b> Exists if OFS2 is set to AL2
41	A2FN	V	V	V	V	V	V	V	<b>TEC-4400/TEC-8400/TEC-8450/TEC-7400/TEC-9400:</b> Exists unconditionally <b>TEC-2400/TEC-6400:</b> Exists if OFS2 is set to AL2
42	A2MD	V	V	V	V	V	V	V	<b>TEC-4400/TEC-8400/TEC-8450/TEC-7400/TEC-9400:</b> Exists if A2FN is set to DEHI,DELO,DBHI,DBLO,PVHI,PVLO,H.BK,H.ST, E1.C.O, or E2.C.O <b>TEC-2400/TEC-6400:</b> Exists if OFS2 is set to AL2 and A2FN is set to DEHI, DELO, DBHI, DBLO, PVHI, PVLO, H.BK, H.ST, E1.C.O or E2.C.O
43	A2HY	V	V	V	V	V	V	V	<b>TEC-4400/TEC-8400/TEC-8450/TEC-7400/TEC-9400:</b> Exists if A2FN is set to DEHI,DELO,DBHI,DBLO,PVHI, or PVLO <b>TEC-2400/TEC-6400:</b> Exists if OFS2 is set to AL2 and A2FN is set to DEHI,DELO,DBHI,DBLO,PVHI, or PVLO
44	A2FT	V	V	V	V	V	V	V	<b>TEC-4400/TEC-8400/TEC-8450/TEC-7400/TEC-9400:</b> Exists if A2FN is set to DTMR,DEHI,DELO,DBHI,DBLO,PVHI, or PVLO <b>TEC-2400/TEC-6400:</b> Exists if OFS2 is set to AL2 and A2FN is set to DTMR,DEHI,DELO,DBHI,DBLO,PVHI, or PVLO
45	A2SP	V	V	V	V	V	V	V	<b>TEC-4400/TEC-8400/TEC-8450/TEC-7400/TEC-9400:</b> Exists if A2FN is set to DTMR,DEHI,DELO,DBHI,DBLO,PVHI, or PVLO <b>TEC-2400/TEC-6400:</b> Exists if OFS2 is set to AL2 and A2FN is set to DTMR,DEHI,DELO,DBHI,DBLO,PVHI, or PVLO
46	A2DV	V	V	V	V	V	V	V	<b>TEC-4400/TEC-8400/TEC-8450/TEC-7400/TEC-9400:</b> Exists if A2FN is set to DEHI,DELO,DBHI,DBLO <b>TEC-2400/TEC-6400:</b> Exists if OFS2 is set to AL2 and A2FN is set to DEHI,DELO,DBHI,DBLO
47	A3OT		V	V	V	V	V		<b>TEC-8400/TEC-8450/TEC-7400/TEC-4400:</b> Exists unconditionally
48	A3FN		V	V	V	V	V		
									<b>TEC-9400:</b> Exists if OFS3 is set to ALM3

Register Address	Parameter Notation	TEC-2400	TEC-9400	TEC-8400	TEC-8450	TEC-7400	TEC-4400	TEC-6400	Existence Conditions
49	A3MD		V	V	V	V	V		<b>TEC-8400/TEC-8450/TEC-7400/TEC-4400:</b> Exists if A3FN is set to DEHI,DELO,DBHI,DBLO,PVHI,PVLO,H.BK, or H.ST <b>TEC-9400:</b> Exists if OFS3 s is set to ALM3, or if A3FN is set to DEHI, DELO, DBHI, DBLO, PVHI, PVLO, H.BK or H.ST
50	A3HY		V	V	V	V	V		<b>TEC-8400/TEC-8450/TEC-7400/TEC-4400:</b> Exists if A3FN is set to DTMR, DEHI, DELO, DBHI, DBLO, PVHI, or PVLO <b>TEC-9400:</b> Exists if OPT3 is set to ALM3, or if A3FN is set to DTMR, DEHI, DELO, DBHI, DBLO, PVHI, or PVLO
51	A3FT		V	V	V	V	V		
52	A3SP		V	V	V	V	V		
53	A3DV		V	V	V	V	V		<b>TEC-4400/TEC-8400/TEC-8450:</b> Exists if OFS3 is set to A.4.20, A.0.20, A.0.5V, A.1.5V or A.0.10 <b>TEC-7400:</b> Exists if OFS3 is set to AL4
54	A4OT			V	V	V	V		<b>TEC-4400/TEC-8400/TEC-8450:</b> Exists if OFS3 is set to A.4.20, A.0.20, A.0.5V, A.1.5V, or A.0.10 and A4FN is set to DEHI, DELO, DBHI, DBLO, PVHI, PVLO, H.BK or H.ST <b>TEC-7400:</b> Exists if OFS3 is set to AL4 and A4FN is set to DEHI, DELO, DBHI, DBLO, PVHI, PVLO, H.BK or H.ST
55	A4FN			V	V	V	V		
56	A4MD			V	V	V	V		<b>TEC-4400/TEC-8400/TEC-8450:</b> Exists if OFS3 is set to A.4.20, A.0.20, A.0.5V, A.1.5V, or A.0.10 and A4FN is set to DEHI, DELO, DBHI, DBLO, PVHI, PVLO, H.BK or H.ST <b>TEC-7400:</b> Exists if OFS3 is set to AL4 and A4FN is set to DEHI, DELO, DBHI, DBLO, PVHI, PVLO, H.BK or H.ST
57	A4HY			V	V	V	V		<b>TEC-4400/TEC-8400/TEC-8450:</b> Exists if OFS3 is set to A.4.20, A.0.20, A.0.5V, A.1.5V or A.0.10 and A4FN is set to DEHI,DELO,DBHI,DBLO,PVHI, or PVLO <b>TEC-7400:</b> Exists if OFS3 is set to AL4 and A4FN is set to DEHI,DELO,DBHI,DBLO,PVHI, or PVLO
58	A4FT			V	V	V	V		<b>TEC-4400/TEC-8400/TEC-8450:</b> Exists if OFS3 is set to A.4.20, A.0.20, A.0.5V, A.1.5V or A.0.10 and A4FN is set to DTMR,DEHI,DELO,DBHI,DBLO,PVHI, or PVLO <b>TEC-7400:</b> Exists if OFS3 is set to AL4 and A4FN is set to DTMR,DEHI,DELO,DBHI,DBLO,PVHI, or PVLO
59	A4SP			V	V	V	V		<b>TEC-4400/TEC-8400/TEC-8450:</b> Exists if OFS3 is set to A.4.20, A.0.20, A.0.5V, A.1.5V or A.0.10 and A4FN is set to PVHI, or PVLO <b>TEC-7400:</b> Exists if OFS3 is set to AL4 and A4FN is set to PVHI, or PVLO
60	A4DV			V	V	V	V		<b>TEC-4400/TEC-8400/TEC-8450:</b> Exists if OFS3 is set to A.4.20, A.0.20, A.0.5V, A.1.5V or A.0.10 and A4FN is set to DEHI,DELO,DBHI,DBLO <b>TEC-7400:</b> Exists if OFS3 is set to AL4 and A4FN is set to DEHI,DELO,DBHI,DBLO
61	BPL1	V	V	V	V	V	V	V	Exists unconditionally
62	BPL2	V	V	V	V	V	V	V	Exists unconditionally
63	CJCL	V	V	V	V	V	V	V	Exists unconditionally
64	PV64	V	V	V	V	V	V	V	Exists unconditionally
65	SV65	V	V	V	V	V	V	V	Exists unconditionally

Register Address	Parameter Notation	TEC-2400	TEC-9400	TEC-8400	TEC-8450	TEC-7400	TEC-4400	TEC-6400	Existence Conditions
66	MV166	V	V	V	V	V	V	V	Exists unconditionally
67	MV267	V	V	V	V	V	V	V	Exists if OUT2 is set to COOL
68	TIMER	V	V	V	V	V	V	V	Exists unconditionally
69	EROR	V	V	V	V	V	V	V	Exists unconditionally
70	MODE	V	V	V	V	V	V	V	Exists unconditionally
71	PROG71	V	V	V	V	V	V	V	Exists unconditionally
72	CMND	V	V	V	V	V	V	V	Exists unconditionally
73	JOB1	V	V	V	V	V	V	V	Exists unconditionally
74	JOB2	V	V	V	V	V	V	V	Exists unconditionally
75	JOB3	V	V	V	V	V	V	V	Exists unconditionally
76	CJCT	V	V	V	V	V	V	V	Exists unconditionally
77	ADLO	V	V	V	V	V	V	V	Exists unconditionally
78	ADHI	V	V	V	V	V	V	V	Exists unconditionally
79	RTDL	V	V	V	V	V	V	V	Exists unconditionally
80	RTDH	V	V	V	V	V	V	V	Exists unconditionally
81	CJLO	V	V	V	V	V	V	V	Exists unconditionally
82	CJHI	V	V	V	V	V	V	V	Exists unconditionally
83	V1L	V	V	V	V	V	V	V	Exists unconditionally
84	V1G	V	V	V	V	V	V	V	Exists unconditionally
85	MA1L	V	V	V	V	V	V	V	Exists unconditionally
86	MA1G	V	V	V	V	V	V	V	Exists unconditionally
87	V2L			V	V	V	V		Exists if OFS1 is not set to NONE and OFS2 is not set to NONE and OFS3 is not set to NONE
88	V2G			V	V	V	V		
89	MA2L			V	V	V	V		
90	MA2G			V	V	V	V		
91	PL1L	V	V	V	V	V	V	V	Exists if PB1≠ 0
92	PL1H	V	V	V	V	V	V	V	
93	PL2L	V	V	V	V	V	V	V	Exists if OUT2 is set to COOL
94	PL2H	V	V	V	V	V	V	V	
95	SEL1	V	V	V	V	V	V	V	Exists unconditionally
96	SEL2	V	V	V	V	V	V	V	Exists unconditionally
97	SEL3	V	V	V	V	V	V	V	Exists unconditionally
98	SEL4	V	V	V	V	V	V	V	Exists unconditionally
99	SEL5	V	V	V	V	V	V	V	Exists unconditionally
100	SEL6	V	V	V	V	V	V	V	Exists unconditionally
101	SEL7	V	V	V	V	V	V	V	Exists unconditionally
102	SEL8	V	V	V	V	V	V	V	Exists unconditionally
103	OFS1	V	V	V	V	V	V	V	Exists unconditionally
104	OFS2	V	V	V	V	V	V	V	Exists unconditionally

Register Address	Parameter Notation	TEC-2400	TEC-9400	TEC-8400	TEC-8450	TEC-7400	TEC-4400	TEC-6400	Existence Conditions
105	OFS3		V	V	V	V	V		Exists unconditionally
106	RETY	V	V	V	V	V	V	V	<b>TEC-4400/TEC-8400/TEC-8450:</b> Exists if OFS3 is set to 4-20, 0-20, 0-5V, 1-5V, 0-10, A.4.20, A.0.20, A.0.5V, A.1.5V, or A.0.10 <b>TEC-7400/TEC-9400:</b> Exists if OFS3 is set to 4-20, 0-20, 0-5V, 1-5V, 0-10 <b>TEC-2400/TEC-6400:</b> Exists if OFS2 is set to 4-20, 0-20, 0-5V, 1-5V, 0-10
107	RELO	V	V	V	V	V	V	V	
108	REHI	V	V	V	V	V	V	V	
109	ADDR	V	V	V	V	V	V	V	Exists if OFS1 is set to RS-485
110	BAUD	V	V	V	V	V	V	V	
111	DATA	V	V	V	V	V	V	V	
112	PARI	V	V	V	V	V	V	V	
113	STOP	V	V	V	V	V	V	V	
114	CT1R	V	V	V	V	V	V	V	<b>TEC-4400/TEC-8400/TEC-8450/TEC-7400:</b> Exists if OFS2 is set to CT1 or CT1.2 <b>TEC-9400:</b> Exists if OFS2 is set to CT1.2 <b>TEC-2400/TEC-6400:</b> Exists if OFS1 select CT1
115	CT2R		V	V	V	V	V	V	<b>TEC-4400/TEC-8400/TEC-8450/TEC-7400:</b> Exists if OFS2 is set to CT1.2 <b>TEC-9400:</b> Exists if OFS2 is set to El.CT or CT1.2 <b>TEC-6400:</b> Exists if OFS2 is set to CT2
116	HBEN	V	V	V	V	V	V	V	<b>TEC-4400/TEC-8400/TEC-8450/TEC-7400:</b> Exists if OFS2 is set to CT1 or CT1.2 <b>TEC-9400:</b> Exists if OFS2 is set to El.CT or CT1.2 <b>TEC-2400:</b> Exists if OFS1 is set to CT1 <b>TEC-6400:</b> Exists if OFS1 is set to CT1 or OFS2 is set to CT2
117	HBHY	V	V	V	V	V	V	V	Exists if HBEN exists and HBEN is set to ON
118	HB1T	V	V	V	V	V	V	V	Exists if CT1R exists and HBEN is set to ON
119	HB2T		V	V	V	V	V	V	Exists if CT2R exists and HBEN is set to ON
120	HSEN	V	V	V	V	V	V	V	<b>TEC-4400/TEC-8400/TEC-8450/TEC-7400:</b> Exists if OFS2 is set to CT1 or CT1.2 <b>TEC-9400:</b> Exists if OFS2 is set to El.CT or CT1.2 <b>TEC-2400:</b> Exists if OFS1 is set to CT1 <b>TEC-6400:</b> Exists if OFS1 is set to CT1 or OFS2 is set to CT2
121	HSYH	V	V	V	V	V	V	V	Exists if HSEN exists and HSEN is set to ON
122	HS1T	V	V	V	V	V	V	V	Exists if CT1R exists and HSEN is set to ON
123	HS2T		V	V	V	V	V	V	Exists if CT2R exists and HSEN are set to ON
124	RMSP			V	V	V	V		<b>TEC-4400/TEC-8400/TEC-8450/TEC-7400:</b> Exists if OFS1 and OFS2 and OFS3 are not all select "None" <b>TEC-9400/TEC-2400/TEC-6400:</b> Does not exist
125	RINL			V	V	V	V		
126	RINH			V	V	V	V		
127	FILE	V	V	V	V	V	V	V	Exists unconditionally
128	PV	V	V	V	V	V	V	V	Exists unconditionally
129	SV	V	V	V	V	V	V	V	Exists unconditionally
130	MV1	V	V	V	V	V	V	V	Exists unconditionally

Register Address	Parameter Notation	TEC-2400	TEC-9400	TEC-8400	TEC-8450	TEC-7400	TEC-4400	TEC-6400	Existence Conditions
131	MV2	V	V	V	V	V	V	V	Exists if OUT2 is set to COOL
132	PASS	V	V	V	V	V	V	V	Exists unconditionally
133	CODE	V	V	V	V	V	V	V	Exists unconditionally
134	OFTL	V	V	V	V	V	V	V	Exists unconditionally
135	OFTH	V	V	V	V	V	V	V	Exists unconditionally
136	CALO	V	V	V	V	V	V	V	Exists unconditionally
137	CAHI	V	V	V	V	V	V	V	Exists unconditionally
140	PROG	V	V	V	V	V	V	V	Exists unconditionally
141	E1FN	V	V	V	V	V	V	V	<b>TEC-4400/TEC-8400/TEC-8450/TEC-7400:</b> Exists unconditionally <b>TEC-9400:</b> Exists if OFS2 is set to EI12 or EICT <b>TEC-2400/TEC-6400:</b> Exists if OFS1 is set to EI1
142	E2FN		V	V	V	V	V	V	<b>TEC-4400/TEC-8400/TEC-8450/TEC-7400:</b> Exists unconditionally <b>TEC-9400:</b> Exists if OFS2 is set to EI12 <b>TEC-6400:</b> Exists if OFS2 is set to EI2
143	E3FN			V	V		V		<b>TEC-4400/TEC-8400/TEC-8450:</b> Exists unconditionally <b>TEC-7400/TEC-9400/TEC-2400/TEC-6400:</b> Does not exist
144	E4FN			V	V		V		
145	E5FN			V	V		V		
146	E6FN			V	V		V		
147	A1DL	V	V	V	V	V	V	V	Exists if OUT2 is set to AL1 or RAL1
148	A2DL	V	V	V	V	V	V	V	<b>TEC-4400/TEC-8400/TEC-8450/TEC-7400/TEC-9400:</b> Exists unconditionally <b>TEC-2400/TEC-6400:</b> Exists if OFS2 is set to AL2
149	A3DL		V	V	V	V	V		<b>TEC-4400/TEC-8400/TEC-8450/TEC-7400:</b> Exists unconditionally <b>TEC-9400:</b> Exists if OFS3 is set to ALM3
150	A4DL			V	V	V	V		<b>TEC-4400/TEC-8400/TEC-8450:</b> Exists if OFS3 is set to A.4.20, A.0.20, A.0.5V, A.1.5V or A.0.10 <b>TEC-7400:</b> Exists if OFS3 is set to AL4
151	SFT	V	V	V	V	V	V	V	Exists unconditionally
152	SFL1	V	V	V	V	V	V	V	Exists if SFT is not set to OFF
153	SFL2	V	V	V	V	V	V	V	Exists if SFT is not set to OFF
154	SFTH	V	V	V	V	V	V	V	Exists if SFT is not set to OFF
155	SFTR	V	V	V	V	V	V	V	Exists if SFT is not set to OFF
161	PROF			V	V	V	V		<b>TEC-4400/TEC-8400/TEC-8450/TEC-7400:</b> Exists unconditionally <b>TEC-9400/TEC-2400/TEC-6400:</b> Does not exist
162	RUN			V	V	V	V		<b>TEC-4400/TEC-8400/TEC-8450/TEC-7400:</b> Exists
163	RMPU			V	V	V	V		
164	STAR			V	V	V	V		

Register Address	Parameter Notation	TEC-2400	TEC-9400	TEC-8400	TEC-8450	TEC-7400	TEC-4400	TEC-6400	Existence Conditions	
165	END			V	V	V	V		if PROF≠0 <b>TEC-9400/TEC-2400/TEC-6400:</b> Does not exist	
166	PFR			V	V	V	V			
167	HBLO			V	V	V	V			
168	HBHI			V	V	V	V			
169	HBT			V	V	V	V			
170	CYCL			V	V	V	V			
171	CYCR			V	V	V	V	<b>TEC-4400/TEC-8400/TEC-8450/TEC-7400:</b> Exists if PROF≠0		
172	STEP			V	V	V	V			<b>TEC-9400/TEC-2400/TEC-6400:</b> Does not exist
173	TIMR			V	V	V	V			
174	STAT			V	V	V	V			
175	TSP1			V	V	V	V			
176	RPT1			V	V	V	V		<b>TEC-4400/TEC-8400/TEC-8450/TEC-7400:</b> Exists if PROF is set to 1, 3, or 7 <b>TEC-9400/TEC-2400/TEC-6400:</b> Does not exist	
177	SKT1			V	V	V	V			
178	TSP2			V	V	V	V			
179	RPT2			V	V	V	V			
180	SKT2			V	V	V	V			
181	TSP3			V	V	V	V			
182	RPT3			V	V	V	V			
183	SKT3			V	V	V	V			
184	TSP4			V	V	V	V			
185	RPT4			V	V	V	V			
186	SKT4			V	V	V	V		<b>TEC-4400/TEC-8400/TEC-8450/TEC-7400:</b> Exists if PROF is set to 2, 3 or 7 <b>TEC-9400/TEC-2400/TEC-6400:</b> Does not exist	
187	TSP5			V	V	V	V			
188	RPT5			V	V	V	V			
189	SKT5			V	V	V	V			
190	TSP6			V	V	V	V			
191	RPT6			V	V	V	V			
192	SKT6			V	V	V	V			
193	TSP7			V	V	V	V			
194	RPT7			V	V	V	V			
195	SKT7			V	V	V	V			
196	TSP8			V	V	V	V	<b>TEC-4400/TEC-8400/TEC-8450/TEC-7400:</b> Exists if PROF is set to 2, 3, or 7 <b>TEC-9400/TEC-2400/TEC-6400:</b> Not exist		
197	RPT8			V	V	V	V			
198	SKT8			V	V	V	V			
199	TSP9			V	V	V	V			
200	RPT9			V	V	V	V	<b>TEC-4400/TEC-8400/TEC-8450/TEC-7400:</b> Exists if PROF is set to 4, 6, or 7 <b>TEC-9400/TEC-2400/TEC-6400:</b> Does not exist		
201	SKT9			V	V	V	V			
202	TSPA			V	V	V	V			

Register Address	Parameter Notation	TEC-2400	TEC-9400	TEC-8400	TEC-8450	TEC-7400	TEC-4400	TEC-6400	Existence Conditions
203	RPTA			V	V	V	V		
204	SKTA			V	V	V	V		
205	TSPB			V	V	V	V		
206	RPTB			V	V	V	V		
207	SKTB			V	V	V	V		
208	TSPC			V	V	V	V		
209	RPTC			V	V	V	V		
210	SKTC			V	V	V	V		
211	TSPD			V	V	V	V		
212	RPTD			V	V	V	V		
213	SKTD			V	V	V	V		
214	TSPE			V	V	V	V		<b>TEC-4400/TEC-8400/TEC-8450/TEC-7400:</b> Exists if PROF is set to 5, 6, or 7 <b>TEC-9400/TEC-2400/TEC-6400:</b> Does not exist
215	RPTE			V	V	V	V		
216	SKTE			V	V	V	V		
217	TSPF			V	V	V	V		
218	RPTF			V	V	V	V		
219	SKTF			V	V	V	V		
220	TSPG			V	V	V	V		
221	RPTG			V	V	V	V		
222	SKTG			V	V	V	V		

**4.8.1. Parameter Availability**

# Custom Manufacturer Since 1972

ELECTRIC HEATING ELEMENTS • TEMPERATURE CONTROLS • SENSORS • PROCESS HEATING SYSTEMS

## HEAT THINGS UP!

With Thousands of Design Variations  
We Make Everything You Need.

Band Heaters	Cartridge Heaters
Cast-In Heaters	Coil & Cable Heaters
Radiant Heaters	Strip Heaters
Flexible Heaters	Tubular Heaters
Process Heaters	Instrumentation
Temperature Control	Temperature Sensors



607 N. Central Avenue Wood Dale, IL 60191-1452 USA  
P: 630-350-2252 Toll Free: 800-323-6859  
F: 630-350-0232 E: [info@tempco.com](mailto:info@tempco.com)  
[www.tempco.com](http://www.tempco.com)