

TEMPCO®

USER MANUAL

TEC-460/960/6600

FM Approved Limit Controller



Warning Symbol

This document contains notices that you should observe to ensure your safety, as well as to protect the product and connected equipment. These notices are highlighted in the manual by a warning triangle and are marked as follows.

 The danger symbol indicates that death or severe personal injury may result if proper precautions are not taken. Do not proceed beyond a warning symbol until the indicated conditions are fully understood and met.

Preface

Original equipment manufacturer reserves the right to change information available in this document without notice. The manufacturer is not liable for any damages incurred to equipment / personal during installation or use of equipment as explained in this document. User must acquire sufficient knowledge & skills before using equipment in the application and follow all the local standards & regulations to meet safety requirements.

Copyright

The documentation is copyrighted 2025 by Tempco Electric Heater Corp. All rights are reserved. Tempco Electric Heater Corp. reserves the right to make improvements or revisions in the products described in this manual at any time without notice.

The information we supply is believed to be accurate and reliable as of this printing. However, we assume no responsibility for its use.

TABLE OF CONTENTS

1	INTRODUCTION	1
1.1	Introduction	1
1.2	Features	2
1.3	Limit Control Function	4
1.3.1	High Limit Control	4
1.3.2	Low Limit Control	4
1.3.3	High / Low Limit Control	4
1.3.4	Using Limit control Function	4
1.4	Specifications	5
1.5	Hardware Codes	8
1.5.1	TEC-460 Hardware Code	8
1.5.2	TEC-960 Hardware Code	9
1.5.3	TEC-6600 Hardware Code	10
1.5.4	Accessories	10
1.5.5	Related Products	10
1.6	Programming Port	11
1.7	Keys and Displays	12
1.8	Menu Flowchart	15
1.8.1	User Access Menu	15
1.8.2	Calibration Menu	16
1.8.3	Setup Menu	17
1.8.3.1	Basic Menu (BASE)	17
1.8.3.2	Output Menu (OUT)	18
1.8.3.3	Communication Menu (COMM)	18
1.8.3.4	Alarm Menu (ALRM)	19
1.8.3.5	Event Input Menu (EI)	19
1.8.3.6	User Menu (SEL)	20
1.9	Parameter Availability Table	20
1.10	Parameters Description	24
2	INSTALLATION AND WIRING	32
2.1	Unpacking	32
2.2	Mounting	32
2.2.1	TEC-460 Dimensions (mm)	33
2.2.2	TEC-960 Dimensions (mm)	34
2.2.3	TEC-6600 Dimensions (mm)	35
2.3	Wiring Precautions	36

2.3.1	TEC-460 Terminal Connections	37
2.3.2	TEC-960 Terminal Connections	38
2.3.3	TEC-6600 Terminal Connections	39
2.4	Power Wiring	40
2.5	Sensor Installation	40
2.6	Sensor Input Wiring	41
2.7	Limit Control Output Wiring	42
2.7.1	Output 1	42
2.8	Alarm Wiring	43
2.8.1	Alarm 1 (Output 2).....	43
2.8.2	Alarm 2.....	43
2.8.3	Alarm 3.....	43
2.9	Event Input Wiring	44
2.10	Retransmission Wiring	44
2.11	RS-485 Data Communication	45
3	PROGRAMMING	46
3.1	User Security	46
3.2	Calibration Security	46
3.3	Signal Input	47
3.4	Limit Control Output	47
3.5	Set Point Range	47
3.6	Alarm	47
3.6.1	Alarm Types	47
3.6.2	Alarm Modes.....	49
3.6.2.1	Normal Alarm: ALMD = NoRM	49
3.6.2.2	Latching Alarm: ALMD = LtCH	49
3.6.2.3	Normal Alarm Reverse Output: ALMD = NoR.R.....	49
3.6.2.4	Latching Alarm Reverse Output: ALMD = LtC.R.....	49
3.6.3	Alarm Failure Transfer	51
3.7	User Select Menu Configuration	51
3.8	User Calibration or PV Shift	51
3.9	Digital Filter	52
3.10	Limit Annunciator	53
3.11	Remote Reset	53
3.12	Remote Lock	53
3.13	Power-Up Logic	53
3.14	Reference Data	54
3.15	Failure Transfer	54

3.15.1	Output 1 Failure Transfer	54
3.15.2	Alarm Failure Transfer	54
3.16	Data Communication.....	54
3.16.1	RS-485 Setup	54
3.17	Retransmission	55
3.18	Event Input.....	55
3.18.1	Event Input Functions	56
4	APPLICATIONS	57
4.1	Limit Controller Application Wiring.....	57
4.2	High Temperature Protection with Remote Reset.....	58
5	CALIBRATION	59
5.1	Equipment Required Before Calibration.....	59
5.1.1	Manual Calibration Procedure	59
5.1.1.1	Calibrate Zero of A to D Converter	59
5.1.1.2	Calibrate Gain of A to D Converter.....	60
5.1.1.3	Calibrate Offset of Cold Junction Compensation.....	60
5.1.1.4	Calibrate Gain of Cold Junction Compensation.....	60
5.1.1.5	Calibrate RTD Input	61
5.1.1.6	Calibrate Linear Input	61
6	COMMUNICATION.....	62
6.1	Functions Supported.....	62
6.1.1	Function Code 03: Read Holding Registers	62
6.1.2	Function Code 06: Pre-Set Single Register.....	62
6.1.3	Function Code 16: Pre-set Multiple Register.....	63
6.2	Exception Responses.....	63
6.3	Parameter Mapping.....	63
6.4	Error Codes.....	64
6.5	Mode	65
6.6	PROG Code	65
6.7	Scaling	65
6.8	Communication Examples	66
6.8.1	6Read PV	66
6.8.2	Perform Reset Function (same effect as pressing the R key).....	66
6.8.3	Read All Parameters	66
6.8.4	Calibrate ADLO	66
6.8.5	Command Mode.....	66

TABLES

Table 1–1 Limit Controller Models	1
Table 2–1 Environmental Specification.....	32
Table 3–1 User Access Rights.....	46
Table 3–2 Calibration Access Rights	46
Table 6–1 Exception Code.....	63
Table 6–2 Operation Mode	65
Table 6–3 Program Code	65
Table 6–4 Data Conversion	65

FIGURES

Figure 1–1 Programming Port	11
Figure 1–2 Programming Port Connection with Programming Port Adaptor	11
Figure 1–3 TEC-460 Front Panel Keys and Display 1/4 DIN	13
Figure 1–4 TEC-960 Front Panel Keys and Display 1/16 DIN	13
Figure 1–5 TEC-6600 Front Panel Keys and Display 35mm DIN Rail Mount	14
Figure 1–6 How Characters are Displayed on the LCD screen	14
Figure 1–7 User Access Menu	15
Figure 1–8 Calibration Menu	16
Figure 1–9 Basic Menu	17
Figure 1–10 Output Menu	18
Figure 1–11 Communication Menu	18
Figure 1–12 Alarm Menu	19
Figure 1–13 Event Input Menu	19
Figure 1–14 User Menu (SEL)	20
Figure 2–1 TEC-460 Dimensions with Clamps	33
Figure 2–2 TEC-460 Dimensions without Clamps (mm)	33
Figure 2–3 TEC-960 Dimensions with Clamps	34
Figure 2–4 TEC-960 Dimensions without Clamps (mm)	34
Figure 2–5 TEC-6600 Dimensions (mm)	35
Figure 2–6 TEC-460 Rear Terminal Connections – High Voltage Input Power	37
Figure 2–7 TEC-460 Rear Terminal Connections – Low Voltage Input Power	37
Figure 2–8 TEC-960 Rear Terminal Connections – High Voltage Input Power	38
Figure 2–9 TEC-960 Rear Terminal Connections – Low Voltage Input Power	38
Figure 2–10 TEC-6600 Terminal Connections – High Voltage Input Power	39
Figure 2–11 TEC-660 Terminal Connections – Low Voltage Input Power	39
Figure 2–12 Power Wiring	40
Figure 2–13 TEC-460 Sensor Input Wiring	41
Figure 2–14 TEC-960 Sensor Input Wiring	41
Figure 2–15 TEC-6600 Sensor Input Wiring	41
Figure 2–16 Output 1 Relay to Drive Load	42
Figure 2–17 Output 1 Relay to Drive Contactor	42
Figure 2–18 Output 1 Pulsed Voltage to Drive SSR	42
Figure 2–19 Alarm 1 Output to Drive Load	43
Figure 2–20 Alarm 2 Output to Drive Load	43
Figure 2–21 Alarm 3 Output to Drive Load	43
Figure 2–22 Event Input Wiring	44
Figure 2–23 Retransmission Wiring - Current	44
Figure 2–24 Retransmission Wiring - Voltage	44
Figure 2–25 RS-485 Wiring	45

Figure 3-1 Process Value High (PV.HI).....48
Figure 3-2 Process Value Low (PV.Lo).....48
Figure 3-3 Process Value High - Normal Alarm50
Figure 3-4 Process Value High - Latching Alarm50
Figure 3-5 Two Point User Calibration52
Figure 3-6 Filter Characteristics52
Figure 4-1 Limit Controller Application Wiring.....57
Figure 4-2 High Temperature Protection With Remote Reset.....58
Figure 5-1 Cold Junction Calibration Setup.....60

1 Introduction

1.1 Introduction

The TEC-460, TEC-960 and TEC-6600 are FM Approved limit controllers that can be configured as a high limit, low limit, or high/low (band) limit controller by the user. These limit controllers are powered by either an 11-26 or 90-250 VDC / VAC supply, depending on which option is chosen when ordering, and incorporating a 2-amp mechanical dry-contact relay output. The second relay output can be used as an alarm.

These controllers can be configured with an optional two event inputs, up to three alarm outputs, RS-485 communications and retransmission voltage or current output. The limit controllers are fully programmable for **Thermocouple types J, K, T, E, B, R, S, N, L, U, P, C, and D**. The input signal is digitized by using an 18-bit A to D converter. Its fast-sampling rate allows the limit controller to protect fast processes. No other sensors can be used.

Below are the different limit controller models of this series.

Model No.	Mounting Type	DIN Size	Dimensions L x W x D (mm)	Depth Behind Panel (mm)
TEC-6600	35mm DIN RAIL	N/A	7/8" x 3 3/4" x 3 3/16" (22.5 x 96 x 80)	N/A
TEC-960	Panel Mount	1/16 DIN	1 7/8" x 1 7/8" x 2 3/8" (48 x 48 x 59)	2" (50)
TEC-460	Panel Mount	1/4 DIN	3 3/4" x 1 7/8" x 2 3/8" (96 x 96 x 59)	2" (50)

Table 1-1 Limit Controller Models

1.2 Features

The new generation of limit controllers has many unique features. The unique features are listed below, some optional:

- LCD Display (using NFPA79 & IEC Standard Colors)
- High Accuracy 18 Bit A-D Conversion and 15 Bit D-A Conversion
- Fastest Sampling Rate of 200 MS
- Universal Thermocouple Input
- Up to 2 Event Inputs
- Remote Reset
- Remote Lock
- RS-485 Modbus RTU Communications
- Lockout Protection
- Bidirectional Menu Navigation
- In Field Calibration
- °C / °F Temperature Ranges / Process Units
- 35 mm DIN Rail Mount
- Configurable display logic - SAFE

LCD Display

All the limit controllers in this series will be equipped with high brightness LCD Display.

Digital Communication

RS-485 Digital communication is available as an additional option. These options allow the units to be integrated with supervisory control systems and software. A Micro USB programming port is available for automatic configuration, calibration and testing without the need to access the keys on the front panel.

High Accuracy

This series of limit controllers are manufactured using an innovative technology which contains an 18-bit A to D converter for high-resolution measurement (true 0.1°F resolution for thermocouple and RTD PT-100 sensors).

Fast Sampling Rate

The sampling rate of the input A to D converter reaches 200 msec. This fast sampling rate allows the limit controller to protect fast processes.

Programming Port

A Micro USB programming port is available for automatic configuration, calibration and firmware upgrades without the need to access the keys on the front panel.

Lockout Protection

According to user security requirements, different security options can be enabled by using the **CODE** and **PASS** parameters.

Digital Filter

A first-order low-pass filter with a programmable time constant is used to improve the stability of the process value (**PV**). This is particularly useful in certain applications where the process value is too unstable to be read.

SEL Function

These limit controllers have the flexibility for the user to select those parameters which are most significant to them and put these parameters into the “**USER**” menu for quick access. There are up to 8 parameters that can be selected to allow the user to build their display sequence in the **USER** menu.

Event Input

Event Inputs are available as an option to change certain functions and the set point. Two event inputs are available in models TEC-460 and TEC-960. One event input is available in model TEC-6600.

Remote Reset

The remote reset can be applied via event input. This will do the same action as reset  key.

Remote Lock



The remote lock can be enabled via event input. This will protect the parameters from unauthorized access.

Analog Retransmission

Analog retransmission is available as an option.

The limit controller has a 15-bit D to A converter for a linear current or voltage retransmission output.

Bidirectional Menu Navigation

The limit controller has bidirectional menu navigation. This allows the user to access the previous menu setting by pressing the   keys at the same time.

1.3 Limit Control Function

When a temperature controller is controlling the temperature of a furnace or other heating device, a malfunction in that temperature controller may cause the furnace temperature to rise, resulting in damage to the heated product or the furnace itself and possibly injury and death. When this situation occurs with the Limit controller, if the temperature rises above the pre-set limit temperature (Heating Application), the limit output will open and the heater system circuit can be shut down to stop the heat source. In addition, the limit output will remain open even when the temperature returns to the normal range. A safer system can be constructed because the limit output will remain open until it is reset manually or via reset via remote reset.

With the Limit Controllers, it is possible to establish a lower limit instead of an upper limit so that the limit function operates when the temperature falls below the limit setting value (Cooling Application). When an input error occurs, the limit output will open and will remain in this condition until the sensor error is fixed and a reset is provided.

1.3.1 High Limit Control

If **HI.** is selected for **OUT1**, the unit will perform high limit control. When power is applied the **OUT1** relay is de-energized. After 6.5 seconds self-test period, if the process is below the high limit set point (**HSP1**), the output 1 relay will be energized and the **OUT1** indicator will go off. If the process goes above the high limit set point, the relay will be de-energized, the **OUT1** indicator will turn on and the display will show the process value. After the process falls below the high limit set point and the reset **[R]** key is pressed or the remote reset input is applied, the relay will be energized and the **OUT1** indicator will go off.

1.3.2 Low Limit Control

If **LO.** is selected for **OUT1**, the unit will perform low limit control. When power is applied the **OUT1** relay is de-energized. After 6.5 seconds self-test period, if the process is above the low limit set point (**LSP1**), the output 1 relay will be energized and the **OUT1** indicator will go off. If the process goes below the low limit set point, the relay will be de-energized, the **OUT1** indicator will turn on and the display will show the process value. After the process rises above the low limit set point and the reset **[R]** key is pressed or the remote reset input is applied, the relay will be energized and the **OUT1** indicator will go off.

1.3.3 High / Low Limit Control

If **HI. LO** is selected for **OUT1**, the unit will perform high/low limit control. When power is applied the **OUT1** relay is de-energized. After 6.5 seconds self-test period, if the process is below the high limit set point (**HSP1**) and above the low limit set point (**LSP1**), the output 1 relay will be energized and the **OUT1** indicator will go off. If the process goes above the high limit set point or below the low limit set point, the relay will be de-energized, the **OUT1** indicator will turn on and the display will show the process value. After the process is within the normal operation range, and the reset **[R]** key is pressed or the remote reset input is applied, the relay will be energized and the **OUT1** indicator will go off.

1.3.4 Using Limit control Function

When the measured temperature (**PV**) exceeds the limit setting value, the limit output relay opens and the **OUT1** operation indicator turns **ON**. If the limit output relay opens (limit alarm is **ON**), the limit output relay will remain open until the operator checks operation (performs resetting operation).

1.4 Specifications

Specification	TEC-6600	TEC-960	TEC-460	
Power Supply	90 to 250VAC, 47 to 63Hz, 20 to 28 VAC, 47-63Hz / 11 to 40 VDC			
Power Consumption	8VA, 4W Maximum	10VA, 5W Maximum	12VA, 6W Maximum	
Signal Input				
Type	Thermocouple (J, K, T, E, B, R, S, N, L, U, P, C, D)			
Resolution	18 Bits			
Sampling Rate	5 Times / Second (200 msec)			
Maximum Rating	-2 VDC minimum, 12 VDC maximum			
Input Characteristics	Type	Range	Accuracy @ 25°C	Input Impedance
	J	-120°C to 1000°C (-184°F to 1832°F)	±2°C	2.2 MΩ
	K	-200°C to 1370°C (-328°F to 2498°F)	±2°C	2.2 MΩ
	T	-250°C to 400°C (-418°F to 752°F)	±2°C	2.2 MΩ
	E	-100°C to 900°C (-148°F to 1652°F)	±2°C (200°C to 1800°C)	2.2 MΩ
	B	0°C to 1820°C (32°F to 3308°F)	±2°C	2.2 MΩ
	R	0°C to 1767.8°C (32°F to 3214°F)	±2°C	2.2 MΩ
	S	0°C to 1767.8°C (32°F to 3214°F)	±2°C	2.2 MΩ
	N	-250°C to 1300°C (-418°F to 2372°F)	±2°C	2.2 MΩ
	L	-200°C to 900°C (-328°F to 1652°F)	±2°C	2.2 MΩ
	U	-200°C to 600°C (-328°F to 1112°F)	±2°C	2.2 MΩ
	P	0°C to 1395°C (32°F to 2543°F)	±2°C	2.2 MΩ
	C	0°C to 2300°C (32°F to 4172°F)	±2°C	2.2 MΩ
D	0°C to 2300°C (32°F to 4172°F)	±2°C	2.2 MΩ	
Temperature Effect	1.5 μV / °C for all inputs except mA input, 3.0 μV / °C for mA			
Sensor Lead Resistance Effect	Thermocouple: 0.2 μV / °Ω			
Burn-out Current	200 nA			
Common Mode Rejection Ratio (CMRR)	120 dB			
Normal Mode Rejection Ratio (NMRR)	55 dB			
Sensor Break Detection	Sensor open for Thermocouple			
Sensor Break Response Time	Within 4 seconds for Thermocouple			
Digital Filter				
Function	First Order			
Time Constant	0,0.2, 0.5, 1, 2, 5, 10, 20, 30, 60 Seconds, Programmable			
Event Input				
Number of Event Inputs	1	2	2	
Logic Low	-10 VDC minimum, 0.8 VDC maximum			
Logic High	2 VDC minimum, 10 VDC maximum			

Specification	TEC-6600	TEC-960	TEC-460
Functions	Remote Lock, Remote Reset Output1, HSP2, LSP2, HLS2, HSP3, LSP3, HLS3, Reset Alarm1, Reset Alarm2, Reset Alarm 3, Reset All Alarms, Cancel Latch, Reset Reference data		
Output 1 / Output 2			
Limit Control Function	High Limit, Low Limit, and High / Low Limit		
Type	Relay, Pulsed Voltage		
Relay Type	Form A		
Relay Rating	2A,240V AC,200000 Life Cycles for Resistive Load		
Pulsed Voltage	Source Voltage 5 VDC, Current Limiting Resistance 66 Ω		
Temperature Effect	±0.01% of Span / °C		
Alarm			
Relay Type	Form A		
Maximum Rating	2A, 240VAC, 200000 Life Cycles for Resistive Load		
Alarm Functions	Process High, Process Low		
Alarm Mode	Normal, Latching, Normal Reverse, Latching Reverse		
Data Communications			
Interface	RS-485		
Protocol	Modbus RTU (Secondary Mode)		
Address	1 to 247		
Baud Rate	2.8 KBPS to 115.2 KBPS		
Parity Bit	None, Even or Odd		
Stop Bit	1 or 2 Bits		
Data Length	7 or 8 Bits		
Communication Buffer	160 Bytes		
Analog Retransmission			
Output Signal	4 - 20 mA, 0 - 20 mA, 0 - 10 VDC		
Resolution	15 Bits		
Accuracy	±0.05% of Span ±0.0025% / °C		
Load Resistance	0 to 500 Ω for current output, 10K Ω minimum for Voltage Output		
Output Regulation	0.01% for full load change		
Output Setting Time	0.1 Second (stable to 99.9%)		
Isolation Breakdown	1000VAC minimum		
Integral Linearity Error	±0.005% of Span		
Temperature Effect	±0.0025% of Span / °C		
Saturation Low	0 mA or 0 VDC		
Saturation High	22.2 mA or 5.55 V, 11.1 V minimum		

Specification	TEC-6600	TEC-960	TEC-460
Linear Output Ranges	0 - 22.2 mA (0 - 20 mA / 4 - 20 mA), 0 - 5.55 VDC (0 - 5 VDC, 1 - 5 VDC), 0 - 11.1 VDC (0 - 10 VDC)		
User Interface			
Keypad	4 Keys		
Display Type	4 Digit LCD Display		
No. of Display	2		
Upper Display Size	0.31" (8mm)	0.58" (15 mm)	0.98" (25 mm)
Lower Display Size	0.25" (6.5 mm)	0.3" (7.8 mm)	0.55" (14 mm)
Programming Port			
Interface	Micro USB		
PC Communication Function	Firmware upgrade		
Environmental and Physical Specifications			
Operating Temperature	14 – 122F (-10° to 50°C)		
Storage Temperature	-40 – 140F (-40° to 60°C)		
Humidity	0 to 90 % RH (Non-Condensing)		
Altitude	6600 FT. (2000 Meters) Maximum		
Pollution	Degree II		
Insulation Resistance	20 MΩ minimum (@ 500 VDC)		
Dielectric Strength	2000 VAC, 50 / 60 Hz for 1 Minute		
Vibration Resistance	10 to 55 Hz, 10 m/s ² for 2 Hours		
Shock Resistance	200 m/s ² (20g)		
Housing	Flame Retardant Polycarbonate		
Mounting	DIN-Rail	Panel	Panel
DIN Size	N/A	1/16	1/4
Dimensions (W*H*D) (mm)	7/8" x 3 3/4" x 3 1/4" (22.5 x 96 x 83)	1 7/8" x 1 7/8" x 2 3/8" (48 x 48 x 59)	3 3/4" x 3 3/4" x 2 3/8" (96 x 96 x 59)
Depth Behind Panel (mm)	N/A	2" (50)	2" (50)
Cut Out Dimensions (mm)	N/A	1 25/32" x 1 25/32" (45 x 45)	3 5/8" x 3 5/8" (92 x 92)
Weight (grams)	6 oz. (160)	6 oz. (160)	11 oz. (290)
Approval Standards			
Safety	FM Class 3545, UL61010-1, EN61010-1 (IEC1010-1), ROHS, REACH		
Protective Class	IP50 for the front panel, IP20 for rear terminals and housing. All indoor use.		
EMC	EN61326		

1.5 Hardware Codes

1.5.1 TEC-460 Hardware Code

(Use Tempco Part Numbers When Ordering)

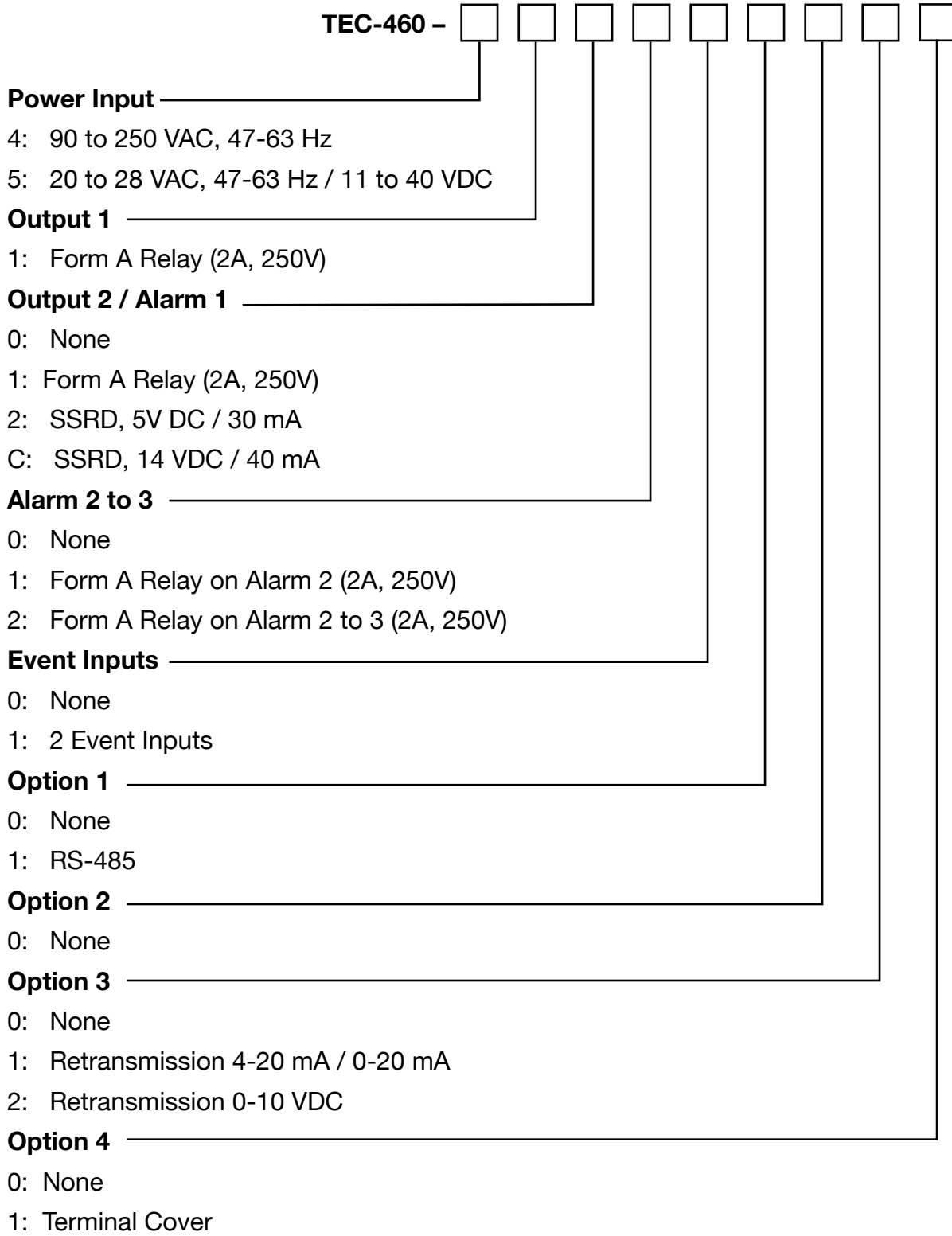

1.5.2 TEC-960 Hardware Code

(Use Tempco Part Numbers When Ordering)

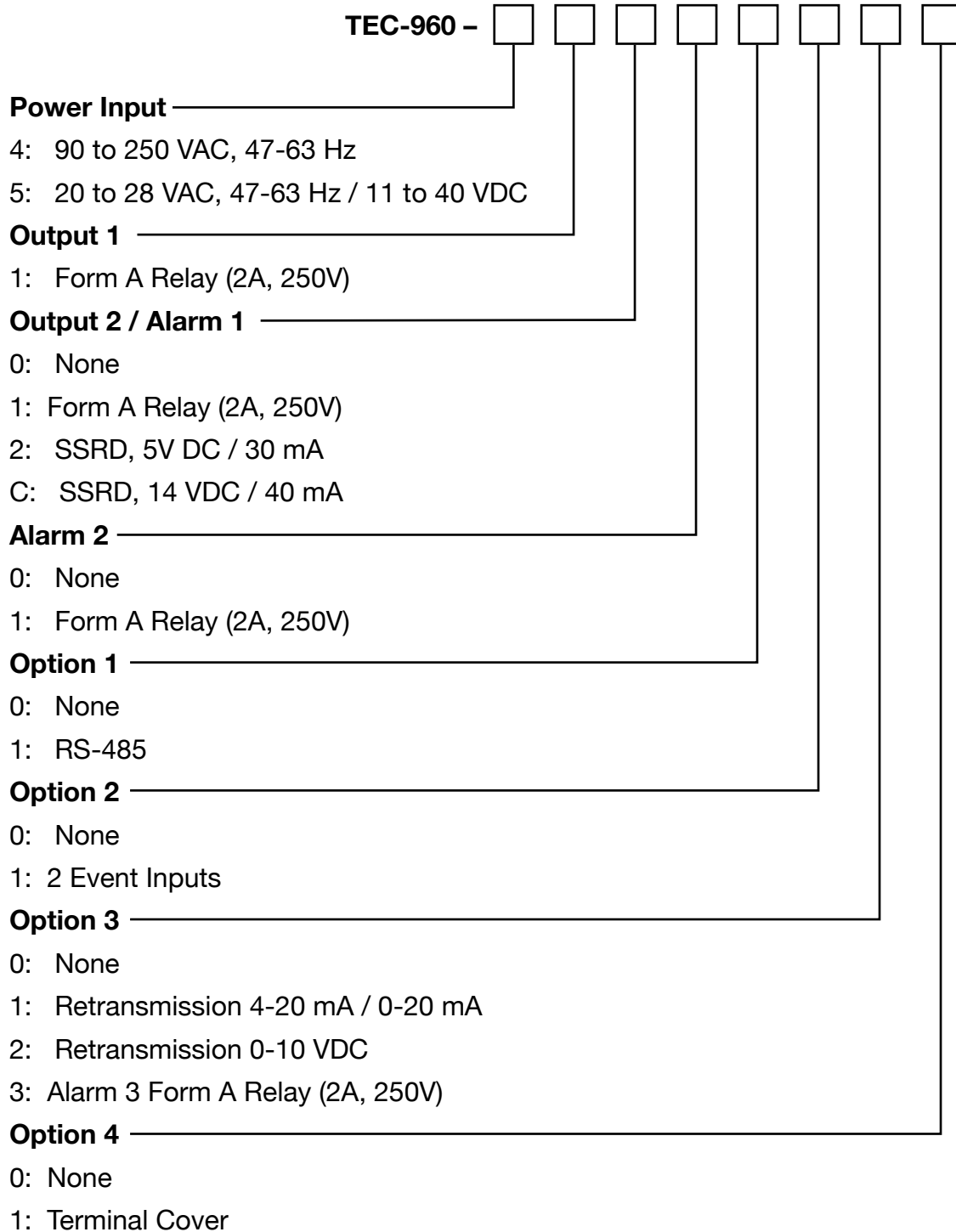

1.5.3 TEC-6600 Hardware Code

(Use Tempco Part Numbers When Ordering)

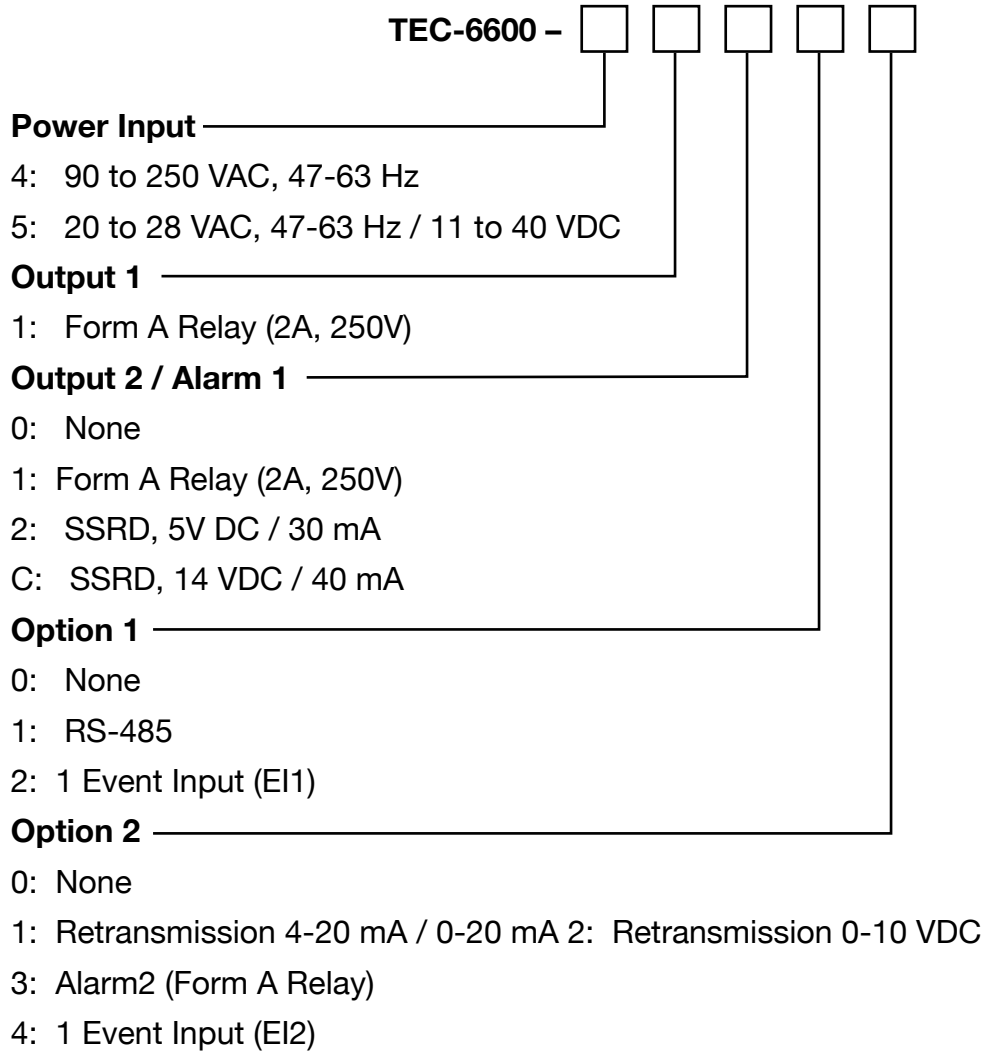

1.5.4 Accessories

TEC99016 = USB Programming Adaptor

TEC99015 = Programming Port Cable (1.5m)

1.5.5 Related Products

TEC99001 - Smart Network Adaptor for third party software, which converts up to 255 channels of RS- 485 or RS-422 to be usable on an RS-232 network.

TEC99030 - Configuration Software “Tempco Config Set”

DOWNLOAD FREE FROM TEMPCO WEBSITE:



1.6 Programming Port

A Micro USB Port provided on the limit controller can be used to connect to a PC by using a programming port cable (TEC99015) and a programming adapter (TEC99016) for firmware upgrades. The programming port is used for off-line loading and copying of preconfigured parameters using “Tempco Config Set” software downloaded free from Tempco.com. Do not attempt to make any connections to this port while the limit controller is being used during normal operation.

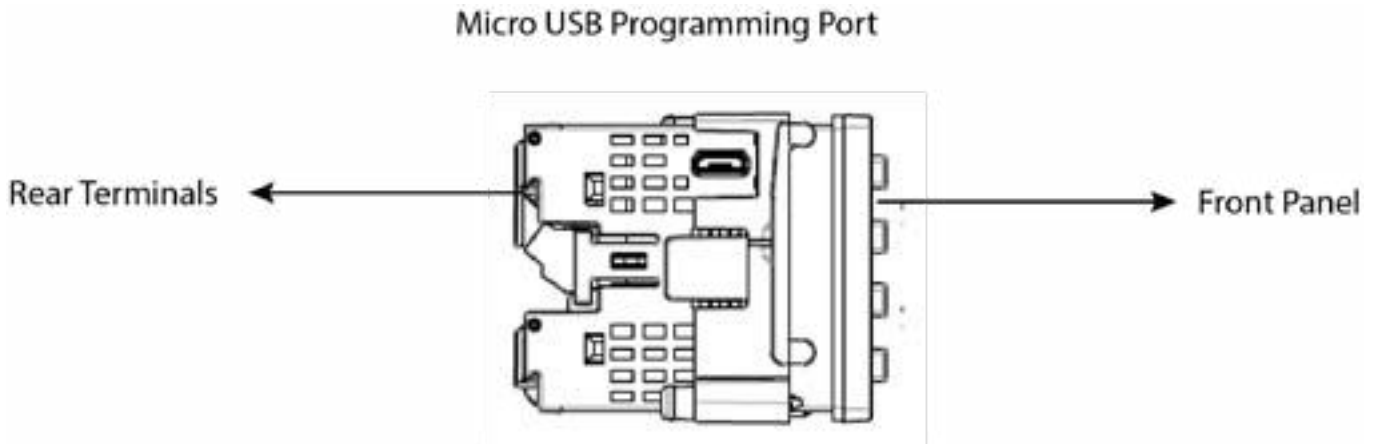

Figure 1-1 Programming Port



Figure 1-2 Programming Port Connection with Programming Port Adaptor

1.7 Keys and Displays

KEYPAD OPERATION

SCROLL KEY:

This key is used to select a parameter to be viewed or adjusted, and to navigate to the next parameter.

Press  and hold for 5 seconds or longer to:

1. Enter the setup menu. The display will show **SET**. Press and hold  for 6.2 seconds, then let go to select calibration mode.
2. Enter calibration mode and perform calibration of a selected parameter during the calibration procedure. The display will show **CALI**.

UP KEY:

This key is used to increase the value of the selected parameter.



DOWN KEY:

This key is used to decrease the value of the selected parameter.

RESET KEY:

This key is used to:

1. Revert the display to the home screen.
2. Reset a latching alarm once the alarm condition is removed.
3. Reset the limit condition after the process is within the limit.
4. Reset the limit annunciator.

NOTE: *If the reset  key is left pressed, only ONE reset operation will occur. If the unit subsequently goes into a state where reset is required again, the reset  key (or remote reset contacts) must be released (opened) and pressed (closed) again.*

POWER-UP SEQUENCE:

During power-up the following sequence will be followed:

1. All segments of display and indicators are left off for 4 seconds.
2. All segments of display and indicators are lit for 1.5 seconds.
3. The upper display will show PROG and the lower display will show the Firmware version for 1.5 seconds.

NORMAL DISPLAY:

During normal operation, the unit will display the process value, and the word SAFE.

ABNORMAL DISPLAY:

Whenever the process is outside the normal range, the lower display will display the limit set point value instead of displaying the word **SAFE**.

SENSOR BREAK DISPLAY:

If a sensor break is detected in the sensor circuit, the display will show: **SBER**.

A-D FAILURE DISPLAY:

If failure is detected in the A-D converter circuit, the display will show: **ADER**.



Figure 1-3 TEC-460 Front Panel Keys and Display 1/4 DIN

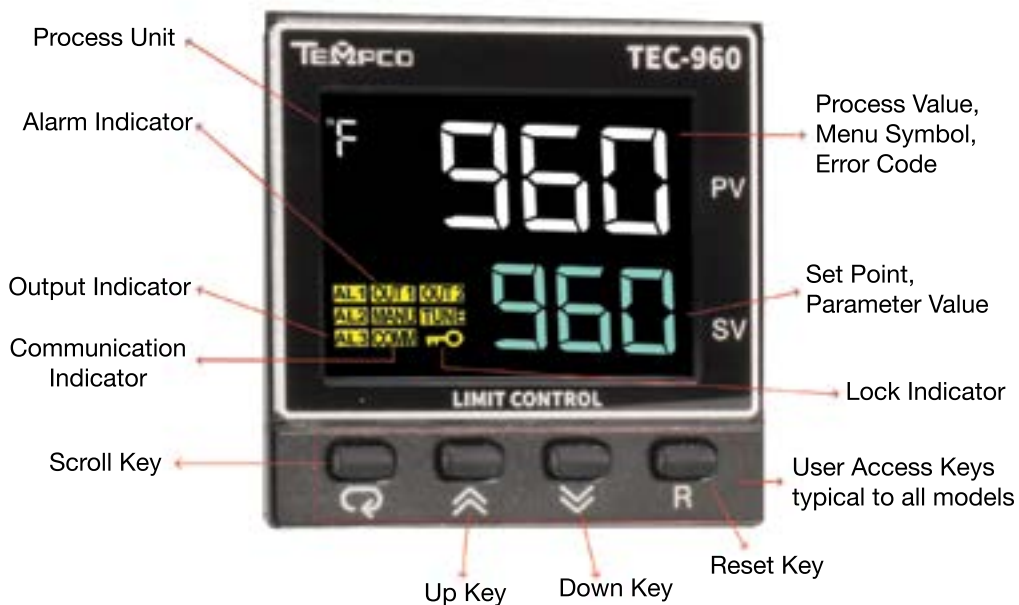

Figure 1-4 TEC-960 Front Panel Keys and Display 1/16 DIN

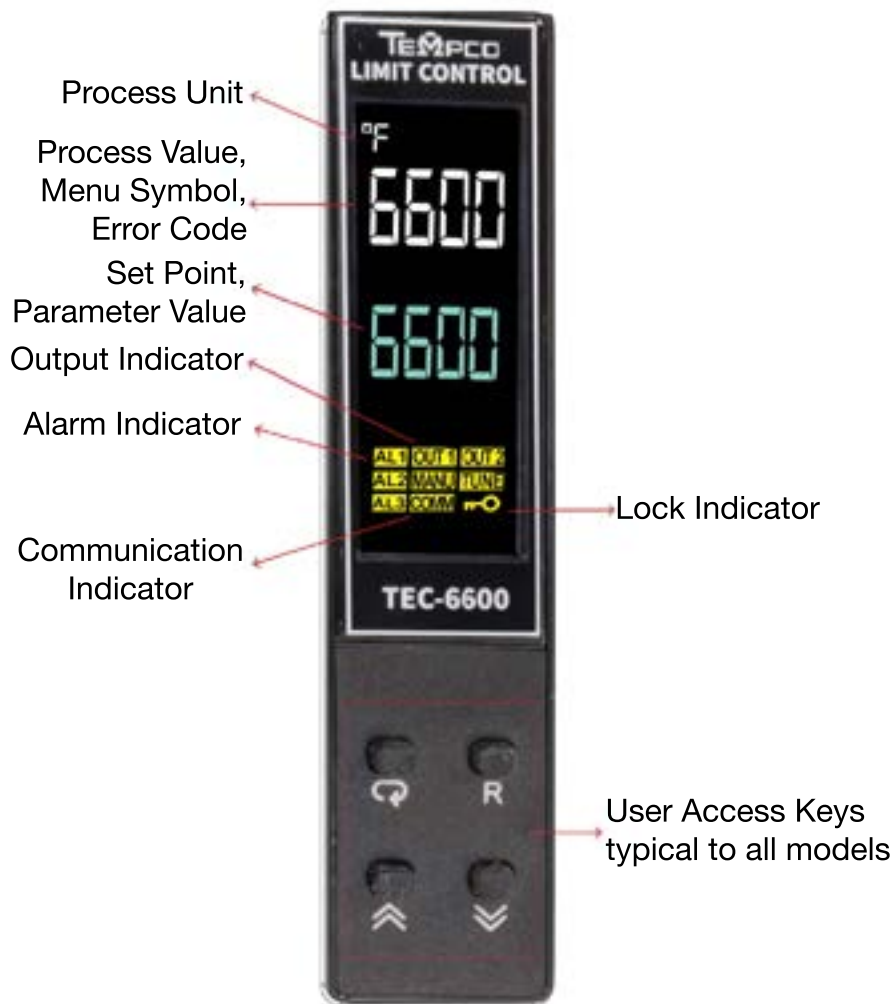

Figure 1-5 TEC-6600 Front Panel Keys and Display 35mm DIN Rail Mount

A	À	B	À	C	Ç	D	Ð	E	Ë	F	Ë	G	Ç
H	H	I	Ì	J	Ï	K	Ë	L	L	M	M	N	N
O	Ó	P	Ï	Q	Ï	R	Ë	S	Ë	T	È	U	Û
V	Ï	W	Ï	X	Ï	Y	Ï	Z	Ï				

Figure 1-6 How Characters are Displayed on the LCD screen

1.8 Menu Flowchart

The Menu has been divided into 3 groups. They are as follows:

1. User Menu - [Pg. 15](#)
2. Setup Menu - [Pg. 17](#)
3. Calibration Mode Menu - [Pg. 16](#) (Not recommended for user)

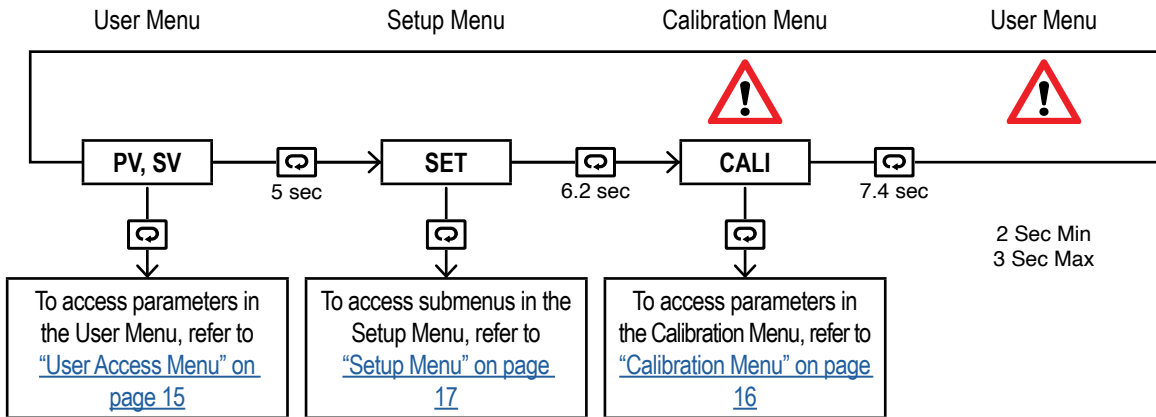

Press → for the next parameter

Press → and ▲ keys simultaneously to return to the previous parameter

Press [R] to return to the home screen (**PV, SV**)

1.8.1 User Access Menu

The following user menu parameters are available depending on the current setup/configuration of the controller. The upper display will show the parameters and the lower display will show its selection. For Error Codes, see [“Error Codes” on page 64.](#)

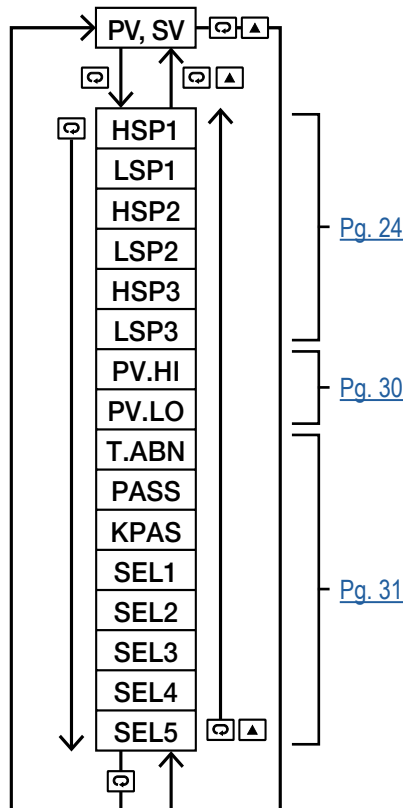



Figure 1-7 User Access Menu

1.8.2 Calibration Menu

NOTE: *Warranty may be voided if parameters have been changed*

Press the  key for 2 seconds or longer (not more than 3 seconds) then release it to enter calibration Mode. KPAS = KCOD for entering to calibration mode.

Press the  key for 5 seconds to perform calibration.

NOTE:

- Calibration modes will break the limit loop and change some of the previous setting data. Make sure that the system is allowable to apply these modes.
- The flow chart shows a complete list of all parameters. For actual application, the number of available parameters will vary depending on the setup and model of the limit controller, and will be less than that shown in the flow chart.

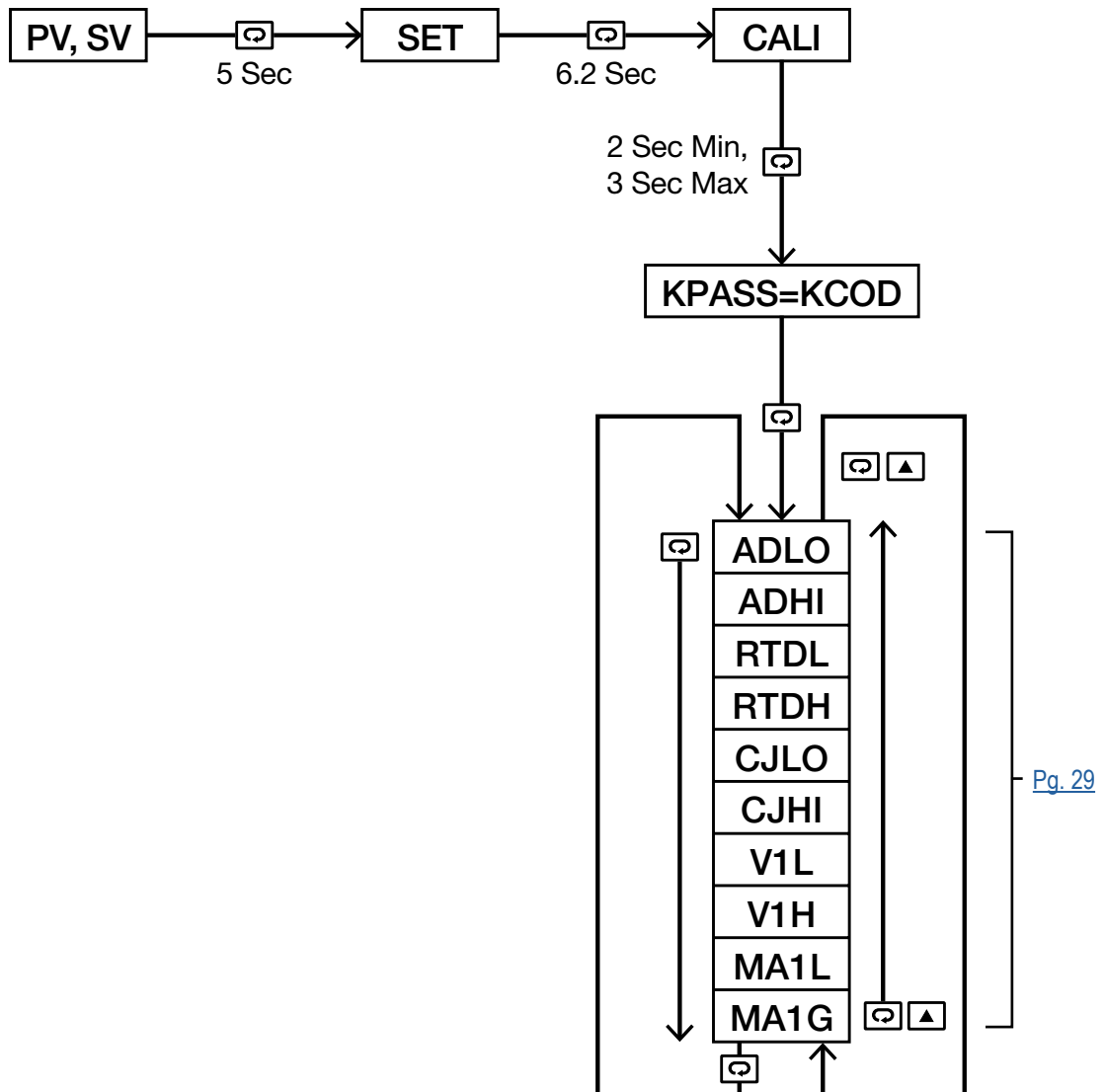





Figure 1-8 Calibration Menu

1.8.3 Setup Menu

The setup menu has been categorized into six submenus for easy user access. They are listed as below.

1. Basic Menu - [Pg. 17](#)
2. Output Menu - [Pg. 18](#)
3. Alarm Menu - [Pg. 19](#)
4. Event Input Menu - [Pg. 19](#)
5. User Menu - [Pg. 20](#)
6. Communication Menu - [Pg. 18](#)

1.8.3.1 Basic Menu (BASE)

From the home screen, press and hold the  key until the upper display shows **SET**, then press the  or  key until **BASE** appears in the lower display. From there, use the  key to cycle through the basic menu parameters. The upper display will show the parameters and the lower display will show its selection.

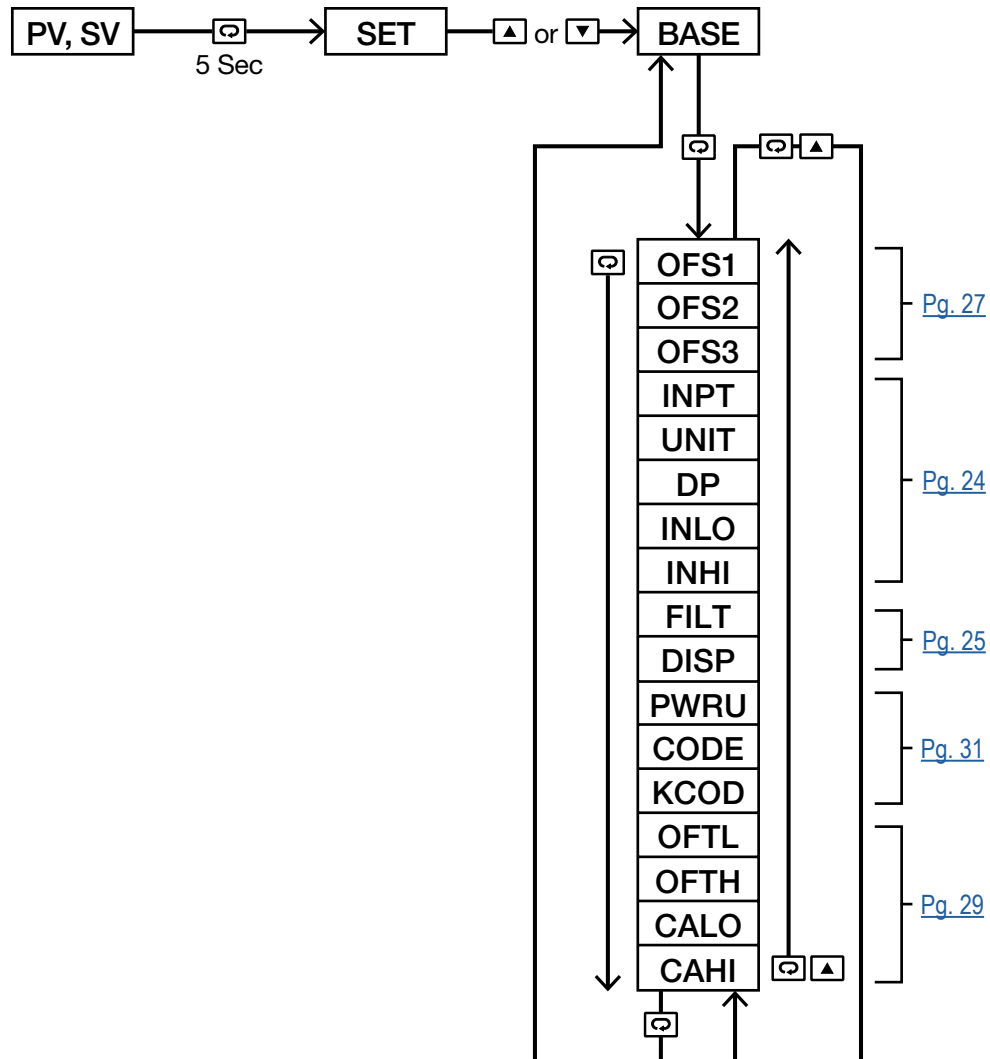





Figure 1-9 Basic Menu

1.8.3.2 Output Menu (OUT)

From the home screen, press and hold the  key until the upper display shows **SET**, then press the  or  key until **OUT** appears in the lower display. From there, use the  key to cycle through the output parameters. The upper display will show the parameters and the lower display will show its selection.

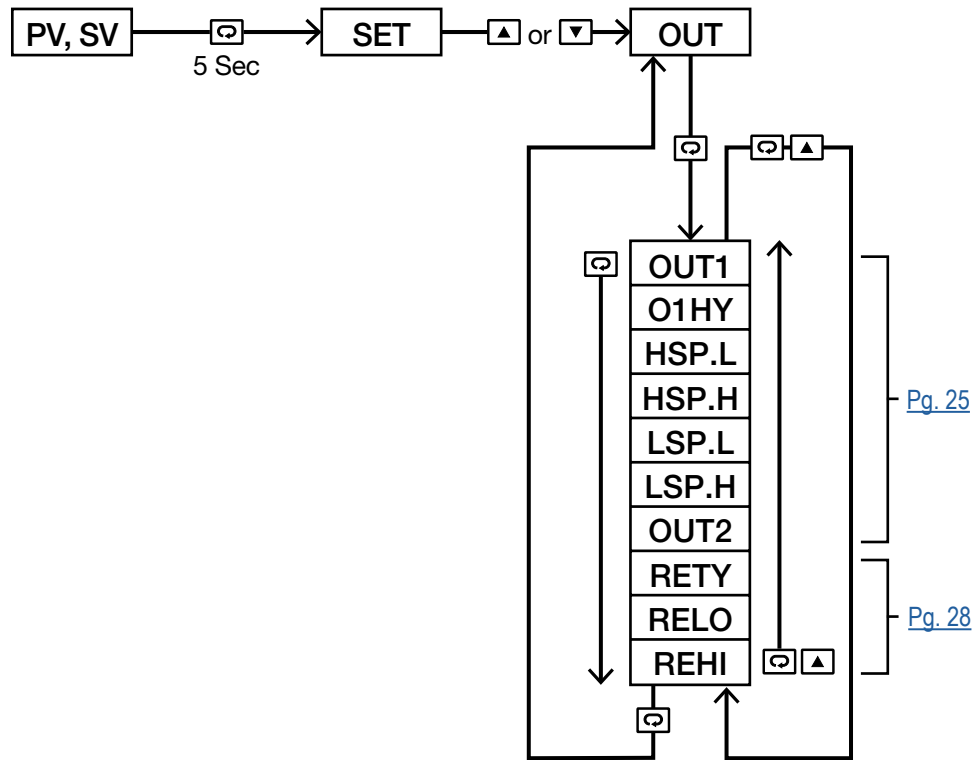





Figure 1-10 Output Menu

1.8.3.3 Communication Menu (COMM)

See [“Data Communication” on page 54](#)

From the home screen, press and hold the  key until the upper display shows **SET**, then press the  or  key until **COMM** appears in the lower display. From there, use the  key to cycle through the communication parameters. The upper display will show the parameters and the lower display will show its selection.

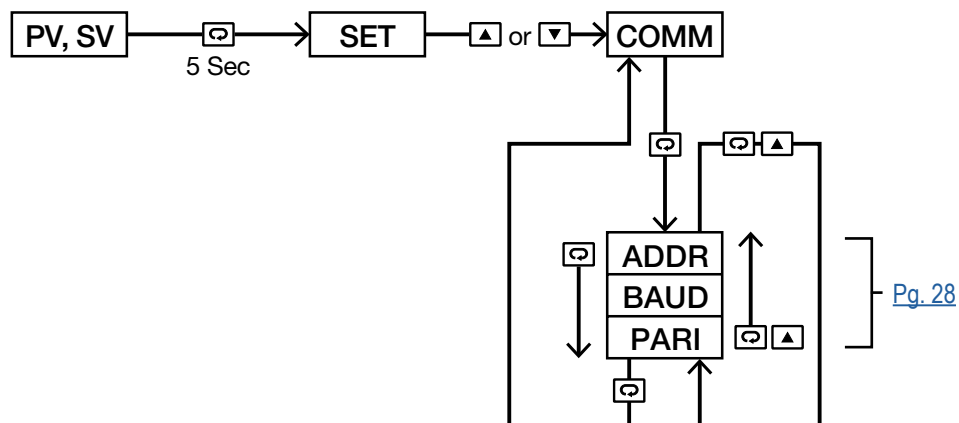





Figure 1-11 Communication Menu

1.8.3.4 Alarm Menu (ALRM)

From the home screen, press and hold the  key until the upper display shows **SET**, then press the  or  key until **ALRM** appears in the lower display. From there, use the  key to cycle through the alarm parameters. The upper display will show the parameters and the lower display will show its selection.

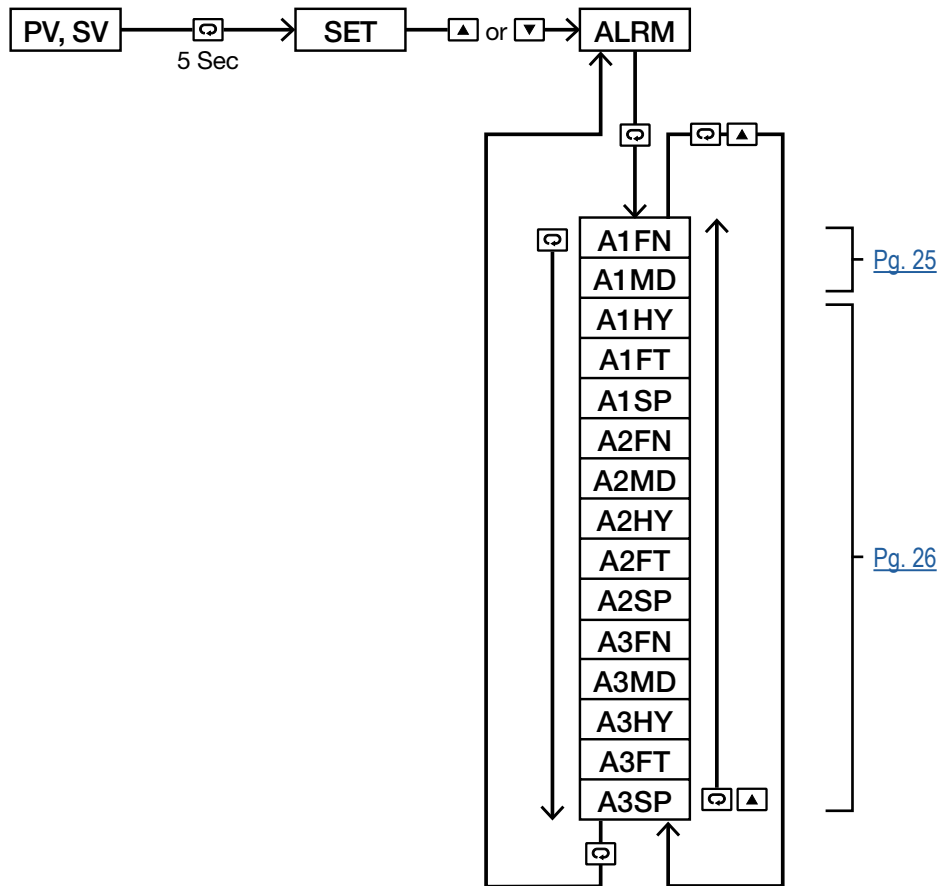





Figure 1-12 Alarm Menu

1.8.3.5 Event Input Menu (EI)

From the home screen, press and hold the  key until the upper display shows **SET**, then press the  or  key until **EI** appears in the lower display. From there, use the  key to cycle through the event input parameters. The upper display will show the parameters and the lower display will show its selection.

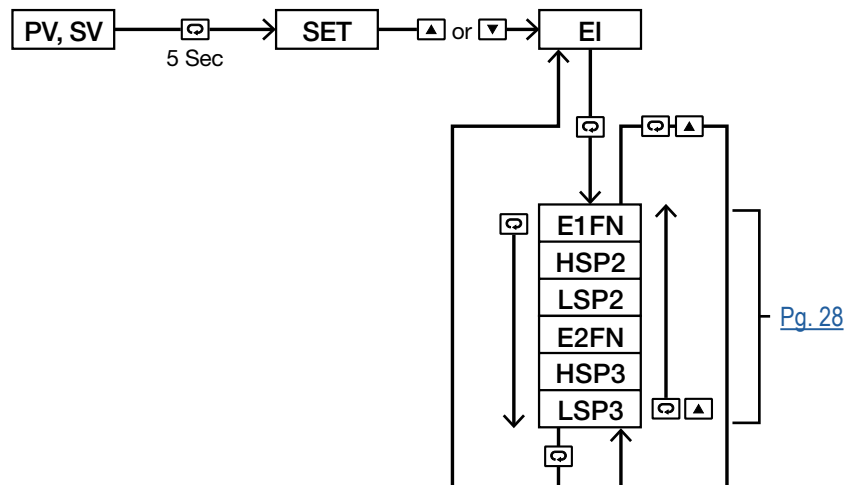





Figure 1-13 Event Input Menu

1.8.3.6 User Menu (SEL)

From the home screen, press and hold the  key until the upper display shows **SET**, then press the  or  key until **SEL** appears in the lower display. From there, use the  key to cycle through the user menu parameters. The upper display will show the parameters and the lower display will show its selection.

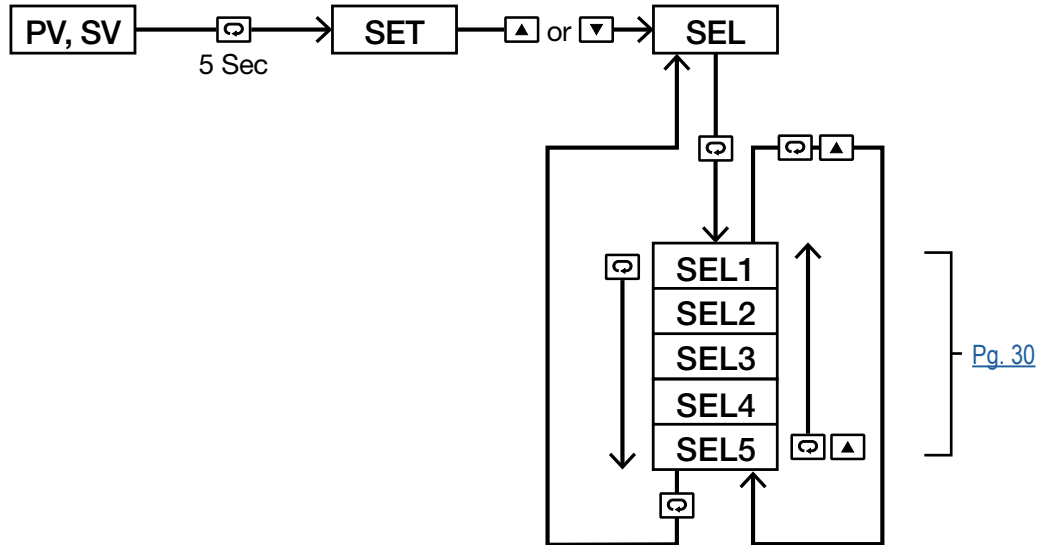

Figure 1-14 User Menu (SEL)

1.9 Parameter Availability Table (Modbus Addresses)

For reference only, see [Pg. 24](#) for actual settings

Modbus Register Address	Parameter Notation	TEC-6600	TEC-960	TEC-460	Existence Conditions
0	HSP1	✓	✓	✓	Exists if OUT1 selects HI or HL
1	LSP1	✓	✓	✓	Exists if OUT1 selects Lo or HL
2	HSP2	✓	✓	✓	Exists if E1FN exists and E1FN selects HSP2 or HLS2 or if E2FN exists and E2FN selects HSP2 or HLS2
3	LSP2	✓	✓	✓	Exists if E1FN exists and E1FN selects LSP2 or HLS2 or if E2FN exists and E2FN selects LSP2 or HLS2
4	HSP3	✓	✓	✓	Exists if E1FN exists and E1FN selects HSP3 or HLS3 or if E2FN exists and E2FN selects HSP3 or HLS3
5	LSP3	✓	✓	✓	Exists if E1FN exists and E1FN selects LSP3 or HLS3 or if E2FN exists and E2FN selects LSP3 or HLS3
6	INPT	✓	✓	✓	Exists unconditionally
7	UNIT	✓	✓	✓	Exists unconditionally
8	DP	✓	✓	✓	Exists unconditionally
9	INLO	✓	✓	✓	Exists if INPT selects 4 - 20mA or 0 - 20mA or 0 - 5V or 1 - 5V or 0 - 10V or 0 - 50mV
10	INH1	✓	✓	✓	
11	HSPL	✓	✓	✓	Exists if OUT1 selects HI or HL
12	HSPH	✓	✓	✓	Exists if OUT1 selects HI or HL
13	LSPL	✓	✓	✓	Exists if OUT1 selects HI or HL

Modbus Register Address	Parameter Notation	TEC-6600	TEC-960	TEC-460	Existence Conditions
14	LSPH	✓	✓	✓	Exists if OUT1 selects HI or HL
15	FILT	✓	✓	✓	Exists unconditionally
16	DISP	✓	✓	✓	Exists unconditionally
17	OUT1	✓	✓	✓	Exists unconditionally
18	O1HY	✓	✓	✓	Exists unconditionally
19	OUT2	✓	✓	✓	Exists unconditionally
20	A1FN	✓	✓	✓	Exists if OUT2 selects AL1
21	A1MD	✓	✓	✓	Exists if OUT2 selects AL1 and A1FN selects PVHI or PVLO
22	A1HY	✓	✓	✓	Exists if OUT2 selects AL1 and A1FN selects PVHI or PVLO
23	A1FT	✓	✓	✓	Exists if OUT2 selects AL1 and A1FN selects PVHI or PVLO
24	A1SP	✓	✓	✓	Exists if OUT2 selects AL1 and A1FN selects PVHI or PVLO
25	A2FN	✓	✓	✓	TEC-960/TEC-460: Exists unconditionally TEC-6600: Exists if OFS2 selects AL2
26	A2MD	✓	✓	✓	TEC-960/TEC-460: Exists if A2FN selects PVHI or PVLO, TEC-6600: Exists if OFS2 selects AL2 and A2FN selects PVHI or PVLO
27	A2HY	✓	✓	✓	
28	A2FT	✓	✓	✓	
29	A2SP	✓	✓	✓	
30	A3FN		✓	✓	TEC-460: Exists unconditionally TEC-960: Exists if OFS3 is set to ALM3 TEC-6600: Not available
31	A3MD		✓	✓	TEC-460: Exists if A3FN selects PVHI or PVLO, TEC-960: Exists if OFS3 is set to ALM3 and A3FN is set to PVHI or PVLO TEC-6600: Not available
32	A3HY		✓	✓	
33	A3FT		✓	✓	
34	A3SP		✓	✓	
35	OFS1	✓	✓	✓	Exists unconditionally
36	OFS2	✓	✓	✓	Exists unconditionally
37	OFS3		✓	✓	TEC-960/TEC-460: Exists unconditionally TEC-6600: Not available
38	E1FN	✓	✓	✓	TEC-460: Exists unconditionally TEC-960: Exists if OFS2 selects EI12 TEC-6600: Exists if OFS1 selects EI1
39	E2FN	✓	✓	✓	TEC-460: Exists unconditionally TEC-960: Exists if OFS2 selects EI12 TEC-6600: Exists if OFS2 selects EI2
40	RETY	✓	✓	✓	TEC-960/TEC-460: Exists if OFS3 selects 4 - 20 or 0 - 20 or 0 - 5V or 1 - 5V or 0 - 10 TEC-6600: Exists if OFS2 selects 4 - 20 or 0 - 20 or 0 - 5V or 1 - 5V or 0 - 10
41	RELO	✓	✓	✓	
42	REHI	✓	✓	✓	
43	ADDR	✓	✓	✓	Exists if OFS1 selects RS-485
44	BAUD	✓	✓	✓	Exists if OFS1 selects RS-485
45	PARI	✓	✓	✓	Exists if OFS1 selects RS-485
46	OFTL	✓	✓	✓	Exists unconditionally

Modbus Register Address	Parameter Notation	TEC-6600	TEC-960	TEC-460	Existence Conditions
47	OFTH	✓	✓	✓	Exists unconditionally
48	CALO	✓	✓	✓	Exists unconditionally
49	CAHI	✓	✓	✓	Exists unconditionally
50					
51	ADLO	✓	✓	✓	Exists unconditionally
52	ADHI	✓	✓	✓	Exists unconditionally
53	RTDL	✓	✓	✓	Exists unconditionally
54	RTDH	✓	✓	✓	Exists unconditionally
55	CJLO	✓	✓	✓	Exists unconditionally
56	CJHI	✓	✓	✓	Exists unconditionally
57	V1L	✓	✓	✓	Exists unconditionally
58	V1G	✓	✓	✓	Exists unconditionally
59	MA1L	✓	✓	✓	Exists unconditionally
60	MA1G	✓	✓	✓	Exists unconditionally
61	CJCL	✓	✓	✓	Exists unconditionally
62	CJCT	✓	✓	✓	Exists unconditionally
63	TABN	✓	✓	✓	Exists unconditionally
64	PV	✓	✓	✓	Exists unconditionally
65	HSV1	✓	✓	✓	Exists unconditionally
66	LSV1	✓	✓	✓	Exists unconditionally
67	PV.HI	✓	✓	✓	Exists unconditionally
68	PV.LO	✓	✓	✓	Exists unconditionally
69	EROR	✓	✓	✓	Exists unconditionally
70	MODE	✓	✓	✓	Exists unconditionally
71	PROG	✓	✓	✓	Exists unconditionally
72	CMND	✓	✓	✓	Exists unconditionally
73	JOB1	✓	✓	✓	Exists unconditionally
74	JOB2	✓	✓	✓	Exists unconditionally
75	JOB3	✓	✓	✓	Exists unconditionally
76	SEL1	✓	✓	✓	Exists unconditionally
77	SEL2	✓	✓	✓	Exists unconditionally
78	SEL3	✓	✓	✓	Exists unconditionally
79	SEL4	✓	✓	✓	Exists unconditionally
80	SEL5	✓	✓	✓	Exists unconditionally
81					
82					
83					
84					
85	PASS	✓	✓	✓	Exists unconditionally
86	KPAS	✓	✓	✓	Exists unconditionally

Modbus Register Address	Parameter Notation	TEC-6600	TEC-960	TEC-460	Existence Conditions
87	CODE	✓	✓	✓	Exists if CODE is 0 or 500, or CODE equal to PASS
88	KCOD	✓	✓	✓	Exists if CODE is 0 or 500, or CODE equal to PASS
128	PV	✓	✓	✓	Exists unconditionally
129	HSV1	✓	✓	✓	Exists unconditionally
130	LSV1	✓	✓	✓	Exists unconditionally
131	T.ABN	✓	✓	✓	Exists unconditionally
132	MODE	✓	✓	✓	Exists unconditionally
133	PWRU	✓	✓	✓	Exists unconditionally
134					
135					
136					
137					
138					
139	EROR	✓	✓	✓	Exists unconditionally
140	PROG	✓	✓	✓	Exists unconditionally
141					
142	CMND	✓	✓	✓	Exists unconditionally
143	JOB1	✓	✓	✓	Exists unconditionally

1.10 Parameters Description

Descriptions start on [Pg. 46](#)

	Modbus Register Address	Parameter Notation	Parameter Description	Range	Default Value	Scale		Data Access Type
						Low	High	
User Menu Pg. 15	0	HSP1	High Limit Set Point1	Low: HSP.L High: HSP.H	212°F (100°C)	-19999	45536	R/W
	1	LSP1	Low Limit Set Point1	Low: LSP.L High: LSP.H	32°F (0°C)	-19999	45536	R/W
	2	HSP2	High Limit Set Point2	Low: -19999 High: 45536	230°F (110°C)	-19999	45536	R/W
	3	LSP2	Low Limit Set Point2	Low: -19999 High: 45536	14°F (-20°C)	-19999	45536	R/W
	4	HSP3	High Limit Set Point3	Low: -19999 High: 45536	194°F (90°C)	-19999	45536	R/W
	5	LSP3	Low Limit Set Point3	Low: -19999 High: 45536	-58°F (-50°C)	-19999	45536	R/W
Basic Menu Pg. 17	6	INPT Pg. 47	Input Sensor Selection (<i>Thermocouple Only</i>)	0 J_tC: J type Thermocouple 1 K_tC: K type Thermocouple 2 t_tC: T type Thermocouple 3 E_tC: E type Thermocouple 4 b_tC: B type Thermocouple 5 R_tC: R type Thermocouple 6 S_tC: S type Thermocouple 7 N_tC: N type Thermocouple 8 L_tC: L type Thermocouple 9 U_tC: U type Thermocouple 10 P_tC: P type Thermocouple 11 C_tC: C type Thermocouple 12 d_tC: D type Thermocouple	0	0	65535	R/W
	7	UNIT Pg. 47	Input Unit Selection	0 oC: °C unit 1 oF: °F unit 2 Pu: Process unit	1	0	65535	R/W
	8	DP Pg. 47	Decimal Point Selection	0 No. dP: No decimal point 1 1-dP: 1 decimal digit	0	0	65535	R/W
Not Used In These Models	9	INLO	Input Low Scale Value	Low: -19999 High: 45536	0°F (-17°C)	-19999	45536	R/W
	10	INHI	Input High Scale Value	Low: -19999 High: 45536	200°F (93°C)	-19999	45536	R/W
Output Menu Pg. 18	11	HSPL Pg. 47	Low Limit of High Limit Set Point Value	Low: -19999 High: HSPH	32°F (0°C)	-19999	45536	R/W
	12	HSPH Pg. 47	High Limit of High Limit Set Point Value	Low: HSPL High: 45536	932°F (500°C)	-19999	45536	R/W
	13	LSPL Pg. 47	Low Limit of Low Limit Set Point Value	Low: -19999 High: LSPH	-148°F (-100°C)	-19999	45536	R/W
	14	LSPH Pg. 47	High Limit of Low Limit Set Point Value	Low: LSPL High: 45536	32°F (0°C)	-19999	45536	R/W

	Modbus Register Address	Parameter Notation	Parameter Description	Range	Default Value	Scale		Data Access Type
						Low	High	
Basic Menu Pg. 17	15	FILT Pg. 52	Filter Damping Time Constant of PV	0 0: 0 second time constant 1 0.2: 0.2 second time constant 2 0.5: 0.5 second time constant 3 1: 1 second time constant 4 2: 2 second time constant 5 5: 5 second time constant 6 10: 10 second time constant 7 20: 20 second time constant 8 30: 30 second time constant 9 60: 60 second time constant	2	0	65535	R/W
	16	DISP	Normal Display Format	0 SAFE: Display SAFE 1 HSP1: Display HSP1 value 2 LSP1: Display LSP1 value	1	0	65535	R/W
Output Menu Pg. 18	17	OUT1 Pg. 47	Output 1 Function	0 HI: High Limit Control 1 LO: Low Limit Control 2 HL: High / Low (Band) Limit Control	0	0	65535	R/W
	18	O1HY	Output Hysteresis	Low: 0.2°F (0.1°C) High: 90°F (50°C)	0.2°F (0.1°C)	0	65535	R/W
	19	OUT2 Pg. 53	Output 2 Function	0 NoNE: Output2 turned off 1 DCPS: DC Power Supply 2 AL1: Alarm 1 Function 3 L_An: Limit Annunciator	2	0	65535	R/W
Alarm Menu Pg. 19	20	A1FN Pg. 47	Alarm 1 Function for Alarm 1 Output	0 NoNE: No alarm function 1 PV.HI: Process value high alarm 2 PV. Lo: Process value low alarm	2	0	65535	R/W
	21	A1MD Pg. 49	Alarm 1 Operation Mode	0 NoRM: Normal alarm action 1 LtCH: Latching alarm action 2 NoR.R: Normal alarm reverse action 3 LtC.R: Latching alarm reverse action	0	0	65535	R/W

Modbus Register Address	Parameter Notation	Parameter Description	Range	Default Value	Scale		Data Access Type
					Low	High	
22	A1HY	Alarm 1 Hysteresis Control	Low: 0.2°F (0.1°C) High: 90°F (50°C)	0.2°F (0.1°C)	0	65535	R/W
23	A1FT Pg. 51	Alarm 1 Failure Transfer Mode	0 oFF: Alarm output OFF if the sensor fails 1 oN: Alarm output ON if the sensor fails	1	0	65535	R/W
24	A1SP	Alarm 1 Set Point	Low: -19999 High: 45536	212°F (100°C)	-19999	45536	R/W
25	A2FN	Alarm 2 Functions For Alarm 2 Output	Same as A1FN	2	0	65535	R/W
26	A2MD	Alarm 2 Operation Mode	Same as A1MD	0	0	65535	R/W
27	A2HY	Alarm 2 Hysteresis Control	Low: 0.2°F (0.1°C) High: 90°F (50°C)	0.2°F (0.1°C)	0	65535	R/W
28	A2FT	Alarm 2 Failure Transfer Mode	0 oFF: Alarm output OFF if the sensor fails 1 oN: Alarm output ON if the sensor fails	1	0	65535	R/W
29	A2SP	Alarm 2 Set Point	Low: -19999 High: 45536	212°F (100°C)	-19999	45536	R/W
30	A3FN	Alarm 3 Functions For Alarm 3 Output	Same as A1FN	2	0	65535	R/W
31	A3MD	Alarm 3 Operation Mode	Same as A1MD	0	0	65535	R/W
32	A3HY	Alarm 3 Hysteresis Control	Low: 0.2°F (0.1°C) High: 90°F (50°C)	0.2°F (0.1°C)	0	65535	R/W
33	A3FT	Alarm 3 Failure Transfer Mode	0 oFF: Alarm output OFF if the sensor fails 1 oN: Alarm output ON if the sensor fails	1	0	65535	R/W
34	A3SP	Alarm 3 Set Point	Low: -19999 High: 45536	212°F (100°C)	-19999	45536	R/W

Alarm Menu
[Pg. 19](#)

	Modbus Register Address	Parameter Notation	Parameter Description	Range	Default Value	Scale		Data Access Type
						Low	High	
Basic Menu Pg. 17	35	OFS1	Option 1*	TEC-460/TEC-960: 0 NoNE: Not selected 1 R485: RS-485 TEC-6600: 0 NoNE: Not selected 1 R485: RS-485 2 EI1: Event 1 input	0	0	65535	R/W
	36	OFS2	Option 2*	TEC-460: 0 NoNE: Not selected TEC-960: 1 NoNE: Not selected 2 EI1.2: Event input 1 and Event input 2 TEC-6600: 0 NoNE: Not selected 1 4-20: 4-20mA retransmission output 2 0-20: 0-20mA retransmission output 3 0-5V: 0-5V retransmission output 4 output 5 1-5V: 1-5V retransmission output 6 output 7 0-10: 0-10 retransmission output 8 output 9 AL2: Alarm 2 output 10 EI2: Event2 Input	0	0	65535	R/W
	37	OFS3	Option 3*	TEC-460: 0 NoNE: Not selected 1 4-20: 4-20mA retransmission output 2 0-20: 0-20mA retransmission output 3 0-5V: 0-5VDC retransmission output 4 1-5V: 1-5VDC retransmission output 5 0-10: 0-10VDC retransmission output TEC-960: 6 NoNE: Not selected 7 4-20: 4-20mA retransmission output 8 0-20: 0-20mA retransmission output 9 0-5V: 0-5VDC retransmission output 10 1-5V: 1-5VDC retransmission output 11 0-10: 0-10VDC retransmission output 12 AL3: Alarm 3 output	0	0	65535	R/W

*** Controllers must have the physical options installed, they cannot be picked by programming only.**

	Modbus Register Address	Parameter Notation	Parameter Description	Range	Default Value	Scale		Data Access Type
						Low	High	
Event Input Menu Pg. 19	38	E1FN Pg. 55	Event Input 1 Function	0 NoNE: none 1 LOCK: Remote Lock 2 RRST: Remote Reset 3 HSP2: HSP2 activated to replace HSP1 4 LSP2: LSP2 activated to replace LSP1 5 HLS2: HSP2 & LSP2 activated to replace HSP1 & LSP1 6 HSP3: HSP3 activated to replace HSP1 7 LSP3: LSP3 activated to replace LSP1 8 HLS3: HSP3 & LSP3 activated to replace HSP1 & LSP1 9 rS.A1: Reset alarm 1 output 10 rS.A2: Reset alarm 2 output 11 rS.A3: Reset alarm 3 output 12 rS.Ao: Reset all alarm outputs 13 CA.LH: Cancel alarm latch 14 R.REF: Reset Reference Data E1FN ≠ E2FN, except selects NONE	0	0	65535	R/W
	39	E2FN	Event Input 2 Function	Same as E1FN E1FN ≠ E2FN, except selects NONE	0	0	65535	R/W
Output Menu Pg. 18	40	RETY Pg. 55	Retransmission Type	0 PV: Retransmit Process Value 1 HSP: Retransmit HSP1 2 LSP: Retransmit LSP1	0	0	65535	R/W
	41	RELO	Retransmission Low Scale Value	Low: -19999 High: 45536	32°F (0°C)	-19999	45536	R/W
	42	REHI	Retransmission High Scale Value	Low: -19999 High: 45536	212°F (100°C)	-19999	45536	R/W
Comm. Menu Pg. 18	43	ADDR Pg. 54	Address Assignment Of Digital Communication	Low: 1 High: 255	----	0	65535	R/W
	44	BAUD	Baud Rate Of Digital Communication	0 2K4: 2.4 Kbits/s baud rate 1 4K8: 4.8 Kbits/s baud rate 2 9K6: 9.6 Kbits/s baud rate 3 14K4: 14.4 Kbits/s baud rate 4 19K2: 19.2 Kbits/s baud rate 5 28K8: 28.8 Kbits/s baud rate 6 38K4: 38.4 Kbits/s baud rate 7 57K6: 57.6 Kbits/s baud rate 8 115K: 115.2 Kbits/s baud rate	2	0	65535	R/W
	45	PARI	The Parity Bit Of Digital Communication	0 EVEN: Even Parity 1 Odd: Odd parity 2 NoNE: No parity bit	0	0	65535	R/W

	Modbus Register Address	Parameter Notation	Parameter Description	Range	Default Value	Scale		Data Access Type
						Low	High	
Basic Menu Pg. 17	46	OFTL Pg. 51	Offset Value For Low Point Calibration	Low: -1999 High: 1999	0	-19999	45536	R/W
	47	OFTH	Offset Value For High Point Calibration	Low: -1999 High: 1999	0	-19999	45536	R/W
	48	CALO	Input Signal Value During Low Point Calibration	Low: -19999 High: CAHI-1 CALO≠CAHI	0	-19999	45536	R/W
	49	CAHI	Input Signal Value During High Point Calibration	Low: CALO+1 High: 45536 CALO≠CAHI	1000	-19999	45536	R/W
Reserved	50							
Calibration Menu Pg. 16	51	ADLO	mV Calibration Low Coefficient	Low: -1999 High: 1999	----	-19999	45536	R/W
	52	ADHI	mV Calibration High Coefficient	Low: -1999 High: 1999	----	-19999	45536	R/W
	53	RTDL	RTD Calibration Low Coefficient	Low: -1999 High: 1999	----	-19999	45536	R/W
	54	RTDH	RTD Calibration High Coefficient	Low: -1999 High: 1999	----	-19999	45536	R/W
	55	CJLO	Cold Junction Calibration Low Coefficient	Low: -5.00 High: 40.00	----	-19999	45536	R/W
	56	CJHI	Cold Junction Calibration High Coefficient	Low: -1999 High: 1999	----	-19999	45536	R/W
	57	V1L	V1 Calibration Low Coefficient	Low: -1999 High: 1999	----	-19999	45536	R/W
	58	V1G	V1 Calibration High Coefficient	Low: -1999 High: 1999	----	-19999	45536	R/W
	59	MA1L	MA1 Calibration Low Coefficient	Low: -1999 High: 1999	----	-19999	45536	R/W
	60	MA1G	MA1 Calibration High Coefficient	Low: -1999 High: 1999	----	-19999	45536	R/W
Read Only	61	CJCL	Sensor Voltage During Cold Junction Calibration Low	Low: 0 High: 7552	----	0	65535	R
	62	CJCT	Cold Junction Temperature	Low: -4000 High: 9000	----	-19999	45536	R
User Menu Pg. 15	63	T.ABN	Accumulated Time During Abnormal Condition	Low: 0.0 High: 6553.5 Minutes	----	0	65535	R
Read Only	64	PV	Current Process Value	Low: -19999 High: 45536	----	-19999	45536	R

	Modbus Register Address	Parameter Notation	Parameter Description	Range	Default Value	Scale		Data Access Type
						Low	High	
Read Only	65	HSV1	Current High Limit Set Point Value	Low: SP1L High: SP1H	----	-19999	45536	R
	66	LSV1	Current Low Limit Set Point Value	Low: SP1L High: SP1H	----	-19999	45536	R
	67	PV.HI	Historical Maximum Value Of PV	Low: -19999 High: 45536	----	-19999	45536	R
	68	PV.LO	Historical Minimum Value Of PV	Low: -19999 High: 45536	----	-19999	45536	R
	69	EROR	Error Code	Low: 0 High: 65535	----	0	65535	R
	70	MODE	Operation Mode & Alarm Status	Low: 0 High: 65535	----	0	65535	R
	71	PROG	Program Code	TEC-460: 45.XX TEC-960: 64.XX TEC-6600: 26.XX	----	0	65535	R
	72	CMND	Command Code	Low: 0 High: 65535	----	0	65535	R/W
	73	JOB1	Job Code	Low: 0 High: 65535	----	0	65535	R/W
	74	JOB2	Job Code	Low: 0 High: 65535	----	0	65535	R/W
	75	JOB3	Job Code	Low: 0 High: 65535	----	0	65535	R/W
User Menu Pg. 15	76	SEL1 Pg. 51	1st Parameter For The User Menu	0 NoNE : No Parameter 1 dISP : DISP 2 o1HY : O1HY 3 A1HY : A1HY 4 A1SP : A1SP 5 A2HY : A2HY 6 A2SP : A2SP 7 OFTL : OFTL 8 OFTH : OFTH 9 CALO : CALO 10 CAHI : CAHI 11 A3HY : A3HY (Only in TEC-460 & TEC-960) 12 A3SP : A3SP (Only in TEC-460 & TEC-960)	0	0	65535	R/W
	77	SEL2	2nd Parameter For The User Menu	Same as SEL1	0	0	65535	R/W
	78	SEL3	3rd Parameter For The User Menu	Same as SEL1	0	0	65535	R/W
	79	SEL4	4th Parameter For The User Menu	Same as SEL1	0	0	65535	R/W
	80	SEL5	5th Parameter For The User Menu	Same as SEL1	0	0	65535	R/W

	Modbus Register Address	Parameter Notation	Parameter Description	Range	Default Value	Scale		Data Access Type
						Low	High	
Reserved	81							
	82							
	83							
	84							
User Menu Pg. 15	85	PASS Pg. 46	Password Entry	Low: 0 High: 9999	0	-32768	32768	R/W
	86	KPAS	Calibration Password Entry	Low: 0 High: 9999	0	-32768	32768	R/W
Basic Menu Pg. 17	87	CODE Pg. 46	Security Code For Parameter Protection	Low: 0 High: 9999	0	-32768	32768	R/W
	88	KCOD Pg. 46	Security Code For Calibration Protection	Low: 0 High: 9999	0	-32768	32768	R/W
Read Only	128	PV	Current Process Value	Low: -19999 High: 45536	----	-19999	45536	R
	129	HSV1	Current High Limit Set Point Value	Low: SP1L High: SP1H	----	-19999	45536	R
	130	LSV1	Current Low Limit Set Point Value	Low: SP1L High: SP1H	----	-19999	45536	R
	131	T.ABN	Accumulated Time During Abnormal Condition	Low: 0.0 High: 6553.5 Minutes	----	0	65535	R
	132	MODE	Operation Mode & Alarm Status	Low: 0 High: 65535	----	0	65535	R
Basic Menu Pg. 17	133	PWRU Pg. 53	Power-Up Logic	0 NoRM :Normal 1 RST: Reset 2 NoRL: Normal Latch	0	0	65535	R/W
Reserved	134							
	135							
	136							
	137							
	138							
Read Only	139	EROR	Error Code	Low: 0 High: 65535	----	0	65535	R
	140	PROG	Program Code	TEC-460: 45.XX TEC-960: 64.XX TEC-6600: 26.XX	----	0	65535	R
Reserved	141							
	142	CMND	Command Code	Low: 0 High: 65535	----	0	65535	R/W
	143	JOB1	Job Code	Low: 0 High: 65535	----	0	65535	R/W

2 Installation and Wiring

⚠ Sometimes dangerous voltages capable of causing death are present in this instrument. Before doing the installation or any troubleshooting procedures, the power to the equipment must be switched off and isolated. Units suspected of being faulty must be disconnected and removed to a properly equipped workshop for testing and repair. Component replacement and internal adjustments must be made by a qualified maintenance person only.

⚠ To minimize the possibility of fire or shock hazards, do not expose this instrument to rain or excessive moisture.

⚠ Do not use this instrument in areas under hazardous conditions such as excessive shock, vibration, dirt, moisture, corrosive gases or oil. The ambient temperature of the area should not exceed the maximum rating specified in the specification

⚠ Remove stains from this equipment using a soft, dry cloth. To avoid deformation, do not use harsh chemicals, volatile solvents such as thinner, or strong detergents to clean the equipment.

⚠ If the equipment is used in a manner not specified by the manufacturer, the protection provided by the equipment may be impaired.

2.1 Unpacking

Upon receipt of the shipment, remove the limit controller from the carton and inspect the unit for shipping damage. If any damage is found, contact your local representative immediately. Note the model number and serial number for future reference when corresponding with our service center. The serial number (S/N) is labeled on the box and the housing of the limit controller.

The limit controller is designed for indoor use only and is not intended for use in any hazardous area. It should be kept away from shock, vibration, and electromagnetic fields (such as variable frequency drives), motors and transformers. It is intended to operate under the following environmental conditions.

Environmental Parameters	Specifications
Operating Temperature	14 to 122°F (-10°C to 50 °C)
Humidity	0% to 90% RH (non-condensing)
Altitude	6600 Ft. (2000 M) Maximum

Table 2-1 Environmental Specification

2.2 Mounting

Make the panel cut out as per the dimensions required by the limit controller. The dimensions of the different sizes of this series limit controller series are given in the following section. Remove the mounting clamps from the limit controller and insert the limit controller into the panel cut out. After inserting the limit controller into the panel cut out, re-install the mounting clamps. Gently tighten the clamp screws until the limit controller is properly secured into the cutout.

2.2.1 TEC-460 Dimensions (mm)

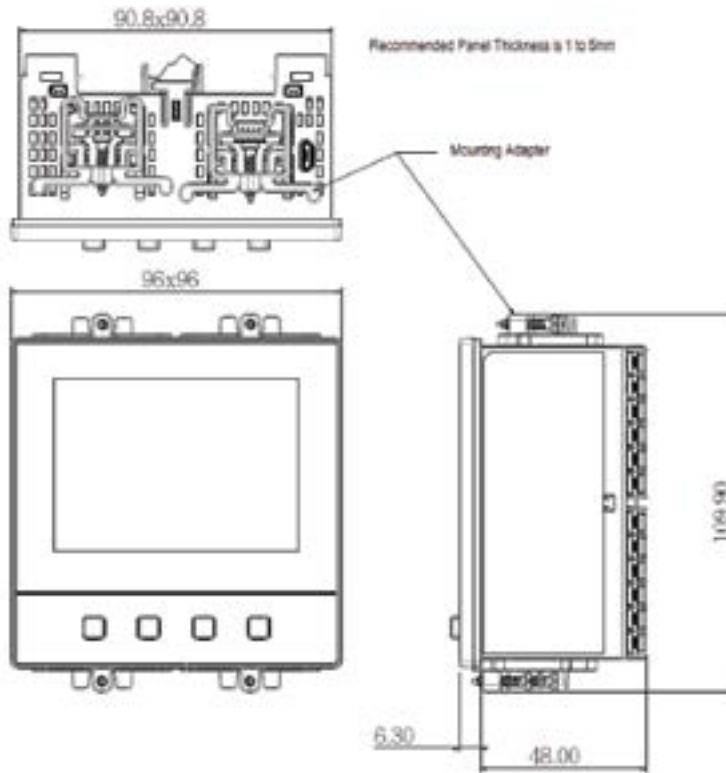

Figure 2-1 TEC-460 Dimensions with Clamps

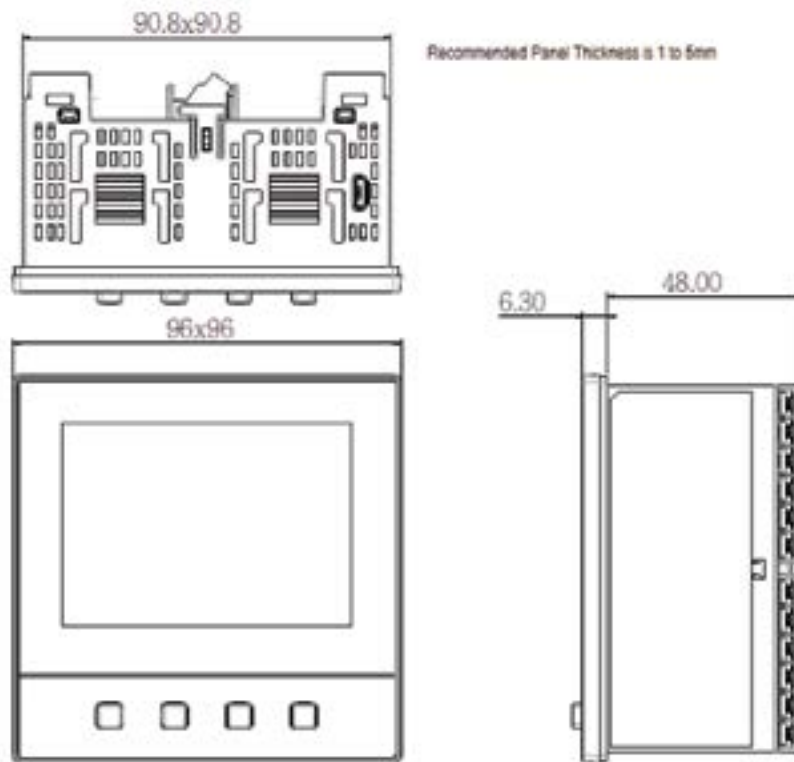

Figure 2-2 TEC-460 Dimensions without Clamps (mm)

2.2.2 TEC-960 Dimensions (mm)

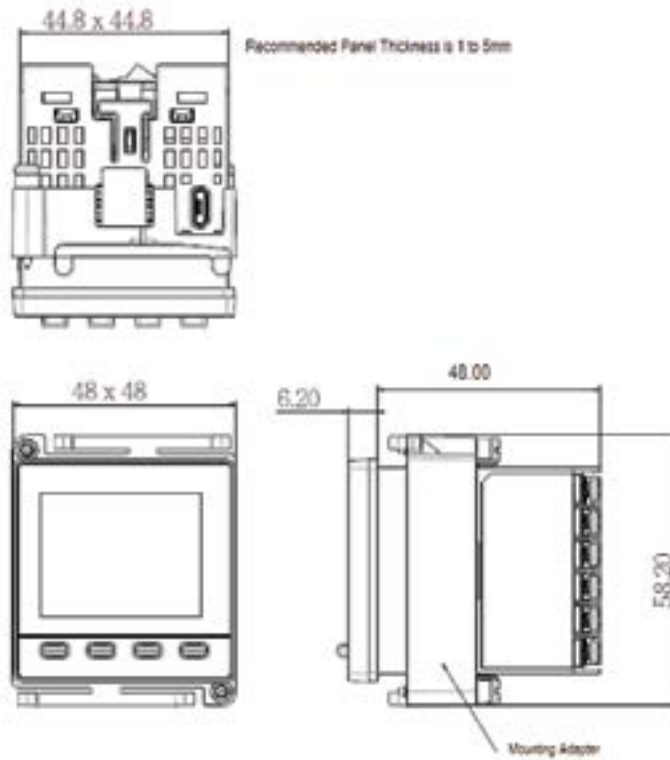

Figure 2-3 TEC-960 Dimensions with Clamps

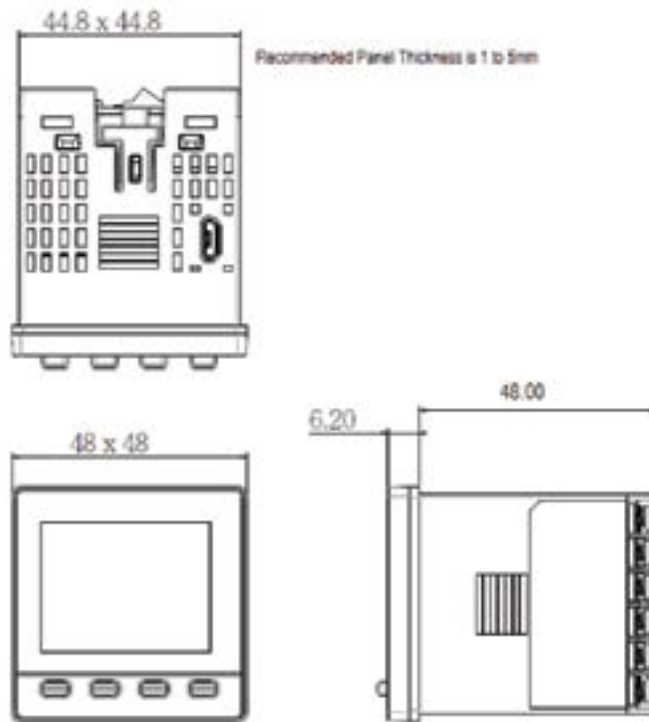

Figure 2-4 TEC-960 Dimensions without Clamps (mm)

2.2.3 TEC-6600 Dimensions (mm)

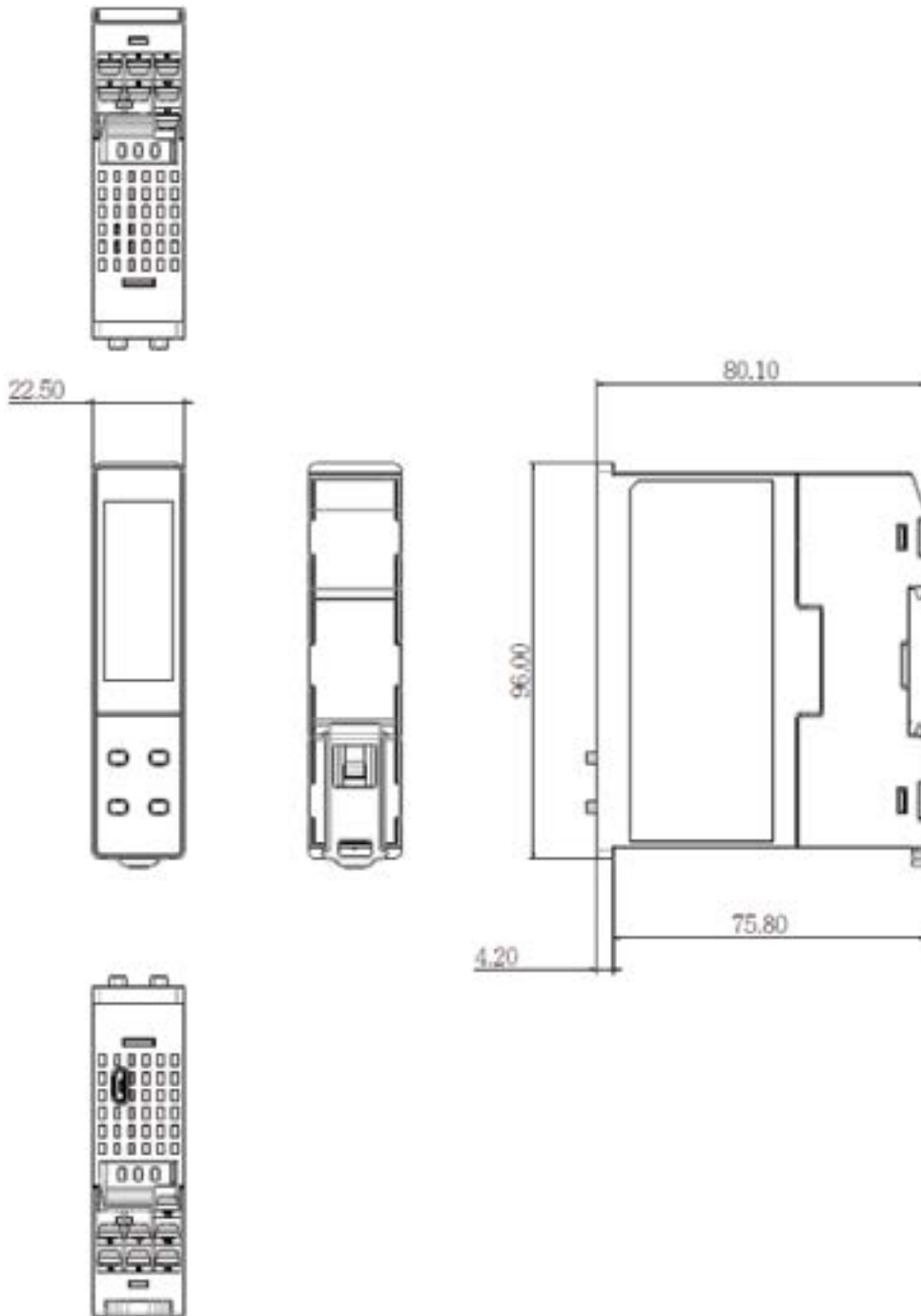

Figure 2-5 TEC-6600 Dimensions (mm)

2.3 Wiring Precautions

⚠ Before wiring, verify the label for correct model number and options. Switch off the power when checking.

⚠ The utmost care must be taken to ensure that maximum voltage rating specified on the label is not exceeded.

⚠ All units should be installed inside a suitably grounded metal enclosure to prevent live electrical parts being accessible to human hands and metal tools. Before powering on the limit controller, the equipment ground must be connected with a minimum of 1.6mm diameter conductor for protective grounding.

⚠ It is recommended that the power supply of these units be protected by fuses or circuit breakers rated at the lowest value possible.

⚠ All wiring must conform to appropriate standards of good practice and local codes and regulations. Wiring must be suitable for maximum voltage, current, and temperature rating of the system.

⚠ Beware not to over-tighten the terminal screws. The torque should not exceed 1N-m (8.9 Lb-in or 10.2 Kg F-cm).

⚠ Unused control terminals should not be used as jumper points as they may be internally connected, causing damage to the unit.

⚠ Verify that the ratings of the output devices and the inputs as specified in [“Applications” on page 57](#) are not exceeded.

⚠ Except the thermocouple wiring, all wiring should use stranded copper conductor with maximum gauge 18 AWG.

⚠ To remove the dust please use a dry cloth.

⚠ Protection impairment may occur if used in a manner not specified by the manufacturer.

⚠ Sometimes dangerous voltages capable of causing death are present in this instrument. Before performing installation or any troubleshooting procedures, the power to the equipment must be switched off and isolated. Units suspected of being faulty must be disconnected and removed to a properly equipped workshop for testing and repair. Component replacement and internal adjustments must be made by a qualified maintenance person only.

2.3.1 TEC-460 Terminal Connections

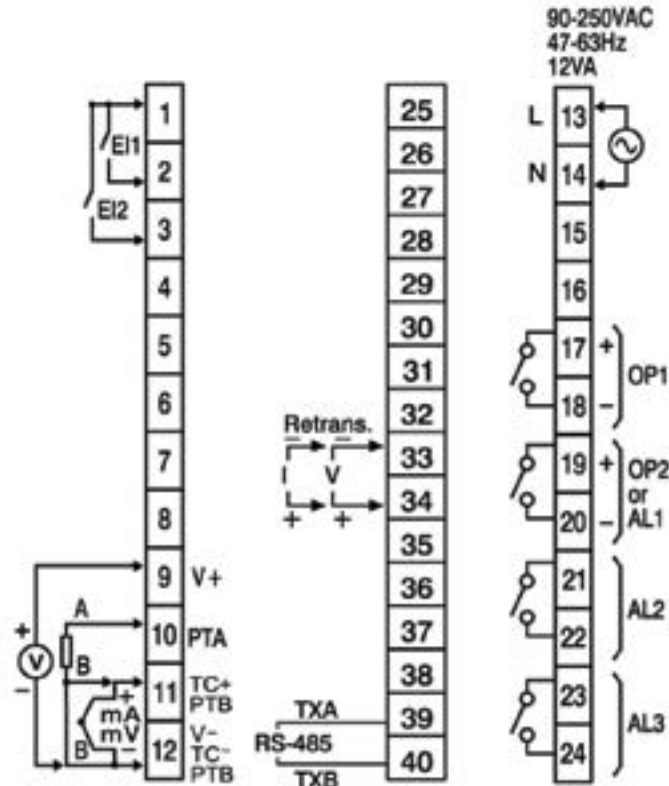

Figure 2-6 TEC-460 Rear Terminal Connections – High Voltage Input Power

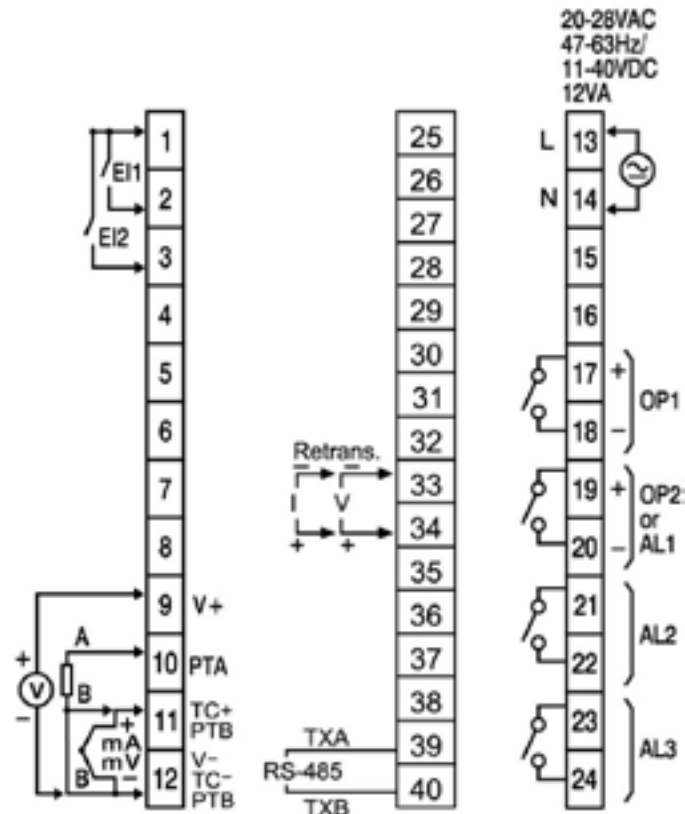

Figure 2-7 TEC-460 Rear Terminal Connections – Low Voltage Input Power

2.3.2 TEC-960 Terminal Connections

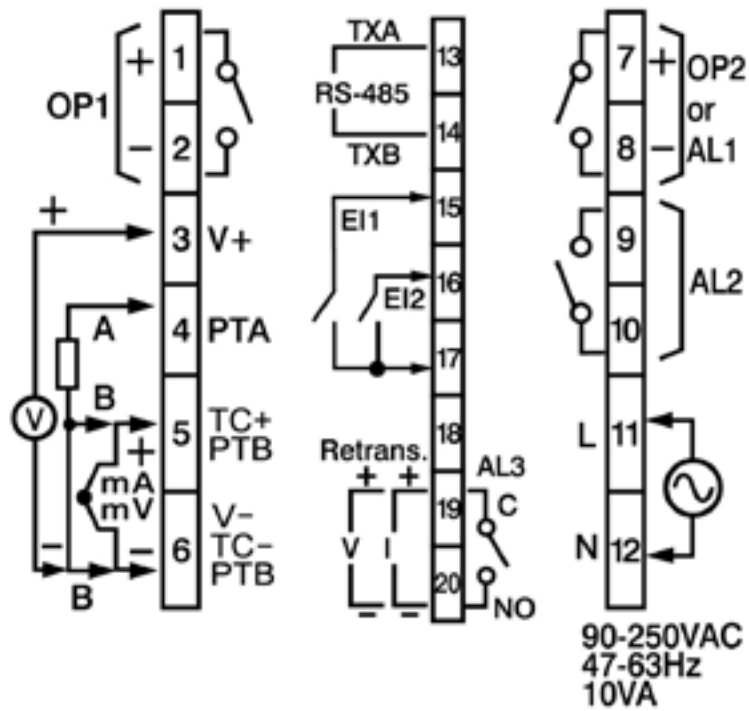

Figure 2-8 TEC-960 Rear Terminal Connections – High Voltage Input Power

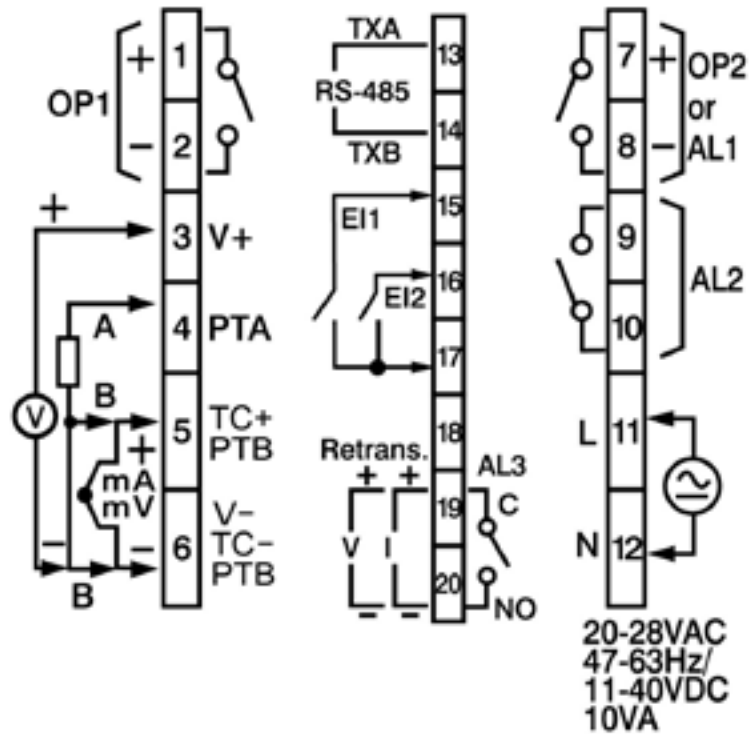

Figure 2-9 TEC-960 Rear Terminal Connections – Low Voltage Input Power

2.4 Power Wiring

The limit controller is designed to operate at either 11-26VAC/VDC or 90-250VAC depending on power input option ordered. Check that the installation voltage corresponds with the power rating indicated on the product label before connecting power to the limit controller. Near the limit controller, a fuse and a switch rated at 2A/250VAC should be equipped as shown below.

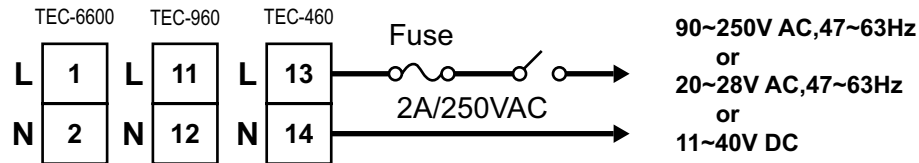

Figure 2-12 Power Wiring

⚠ This equipment is designed for installation in an enclosure which provides adequate protection against electric shock.

⚠ Local requirements regarding electrical installation should be rigidly observed. Consideration should be given to prevent unauthorized persons from accessing the power terminals.

2.5 Sensor Installation

Proper sensor installation can eliminate many problems in a control system. The probe should be placed so that it can detect any temperature change with minimal thermal lag. In a process that requires fairly constant heat output, the probe should be placed close to the heater. In a process where the heat demand is variable, the probe should be placed close to the work area. Some experiments with probe location are often required to find this optimum position.

In a liquid process, the addition of a stirrer or agitator can help to eliminate thermal lag. Since the thermocouple is a point measuring device, placing more than one thermocouple in parallel can provide average temperature readout and produce better results in most air heated processes.

The proper sensor type is also a very important factor to obtain precise measurements. The sensor must have the correct temperature range to meet the process requirements. In special processes, the sensor might need to have different requirements such as being leak-proof, anti-vibration, antiseptic, etc.

Standard sensor limits of error are $\pm 4^{\circ}\text{F}$ ($\pm 2^{\circ}\text{C}$) or 0.75% of sensed temperature (half that for special) plus drift caused by improper protection or an over-temperature occurrence.

This error is far greater than controller error and cannot be corrected on the sensor except by proper selection and replacement.

2.6 Sensor Input Wiring

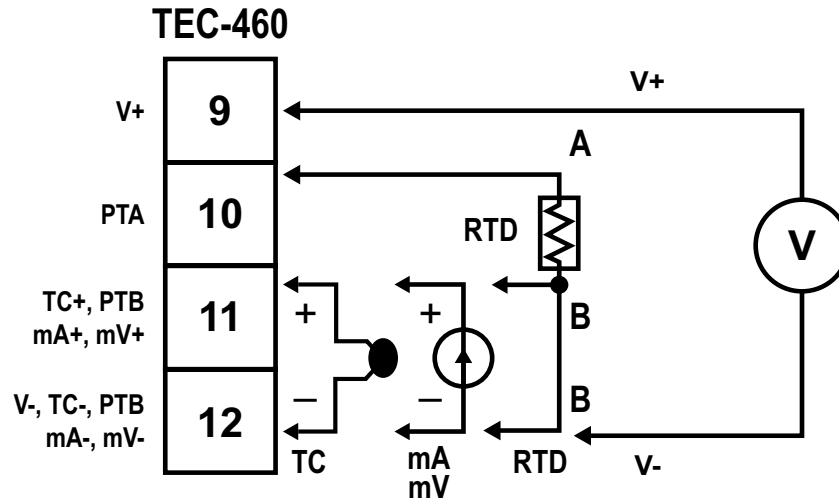

Figure 2-13 TEC-460 Sensor Input Wiring

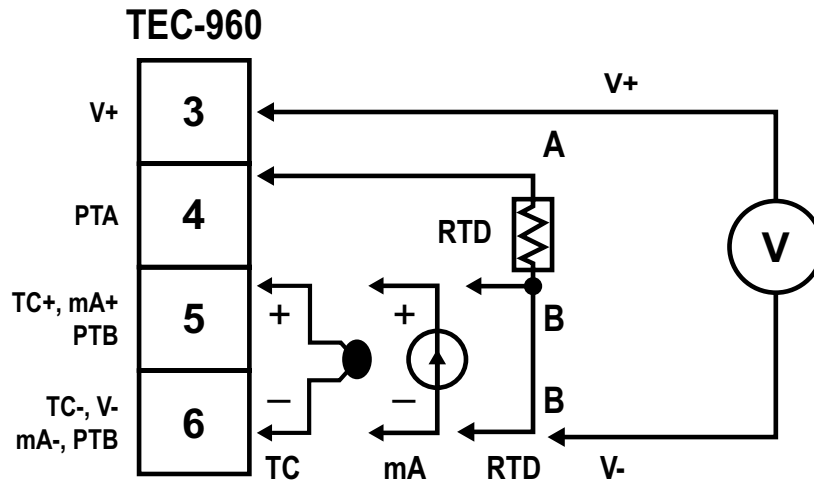

Figure 2-14 TEC-960 Sensor Input Wiring

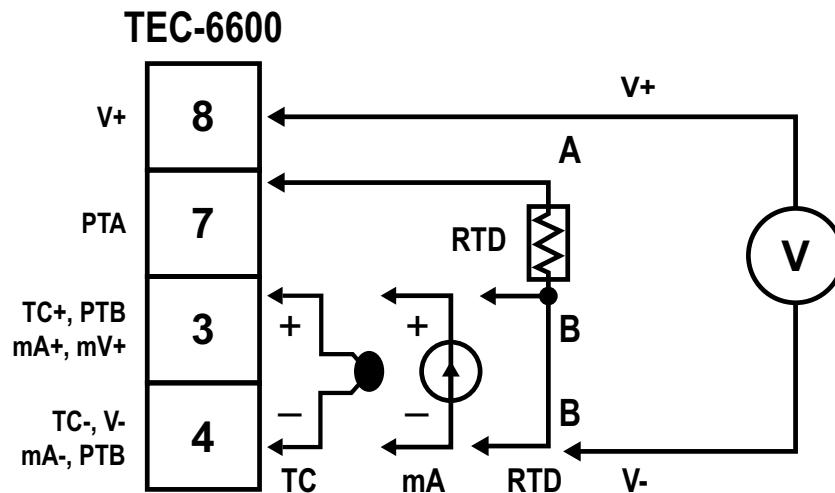

Figure 2-15 TEC-6600 Sensor Input Wiring

2.7 Limit Control Output Wiring

2.7.1 Output 1

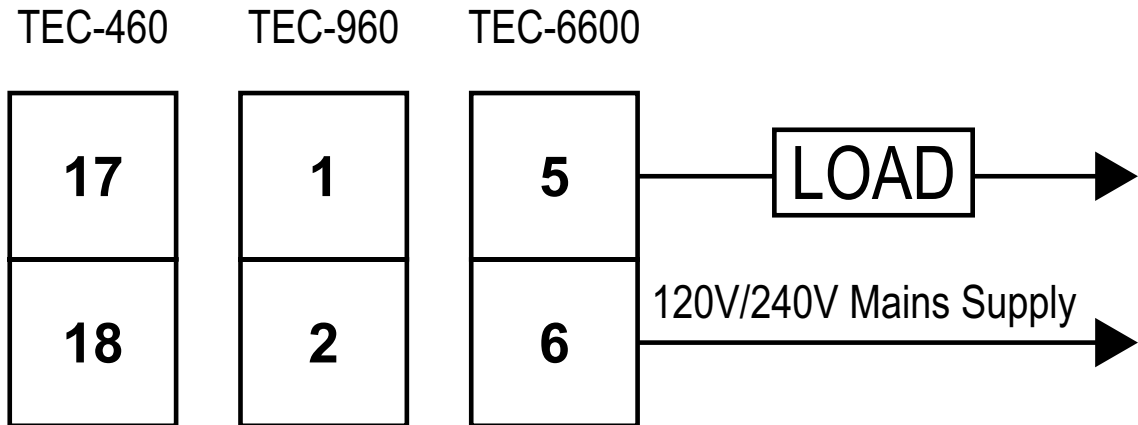

Figure 2-16 Output 1 Relay to Drive Load

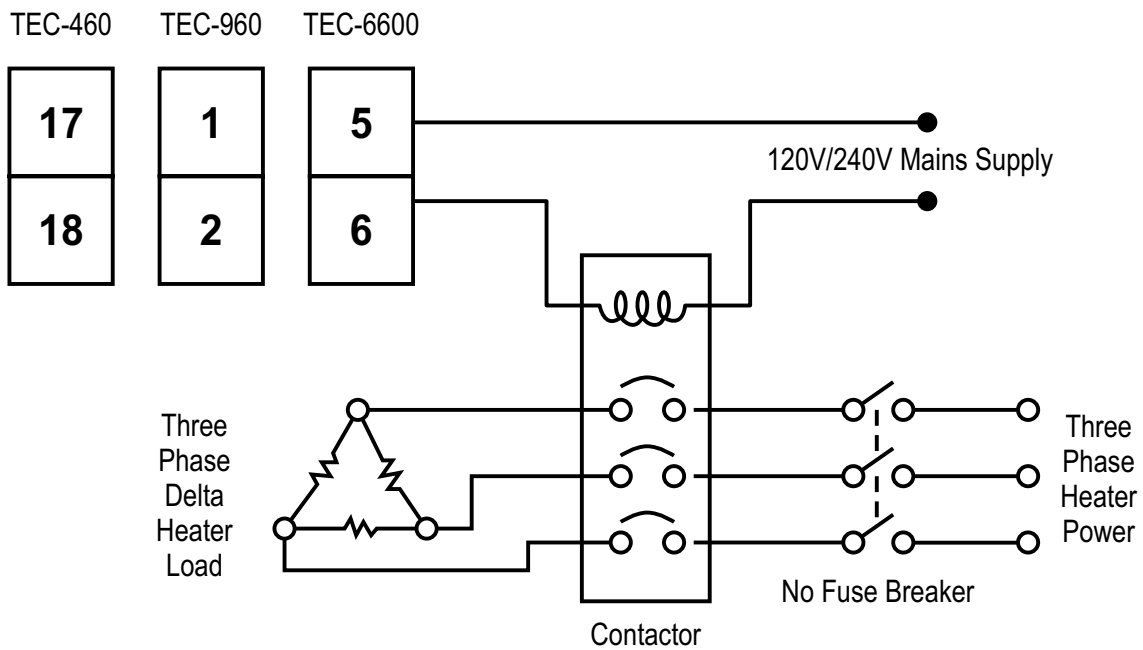

Figure 2-17 Output 1 Relay to Drive Contactor

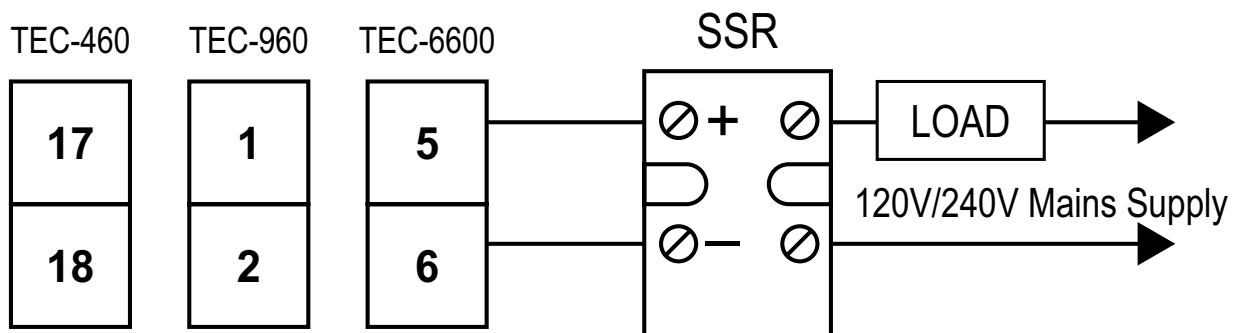

Figure 2-18 Output 1 Pulsed Voltage to Drive SSR

2.8 Alarm Wiring

2.8.1 Alarm 1 (Output 2)

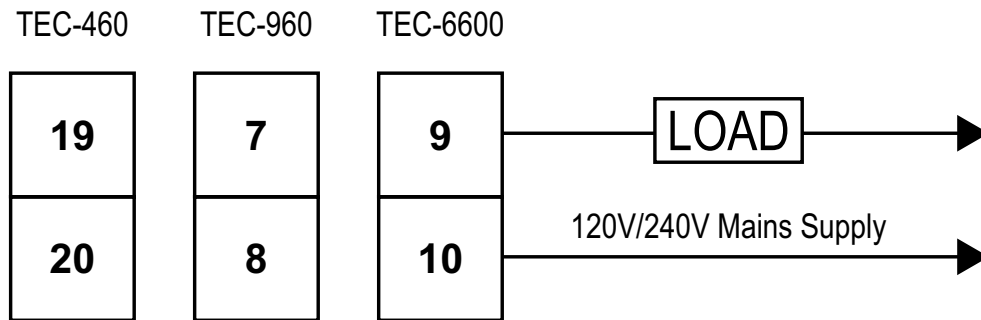

Figure 2-19 Alarm 1 Output to Drive Load

2.8.2 Alarm 2

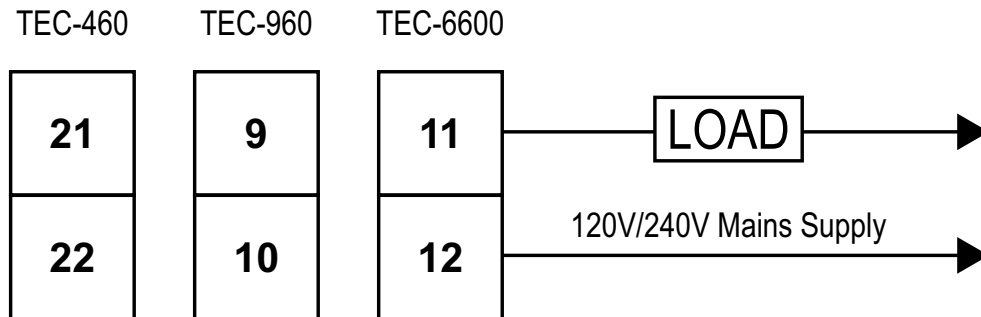

Figure 2-20 Alarm 2 Output to Drive Load

2.8.3 Alarm 3

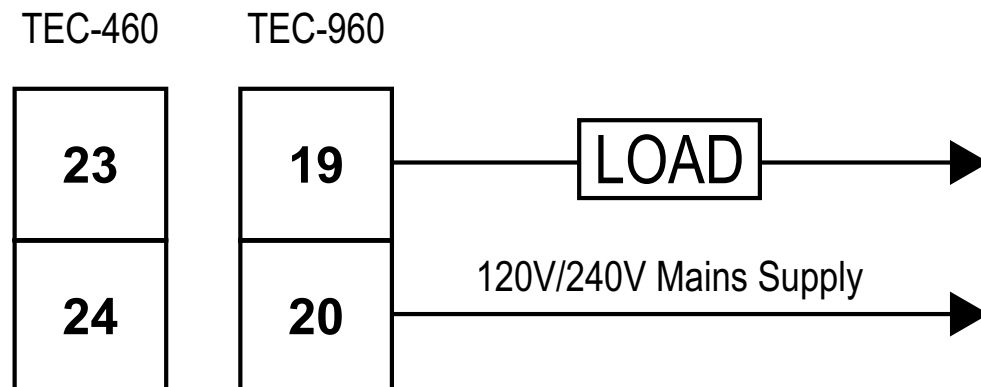

Figure 2-21 Alarm 3 Output to Drive Load

2.9 Event Input Wiring

The event input can accept a switch (dry contact) or an open collector signal. The event input function **E1FN** (38) is activated as the switch is closed or an open collector (or a logic signal) is pulled down.

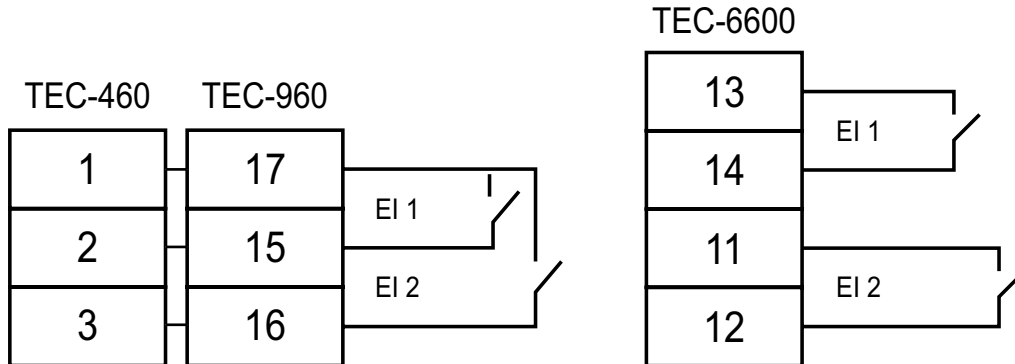

Figure 2-22 Event Input Wiring

2.10 Retransmission Wiring

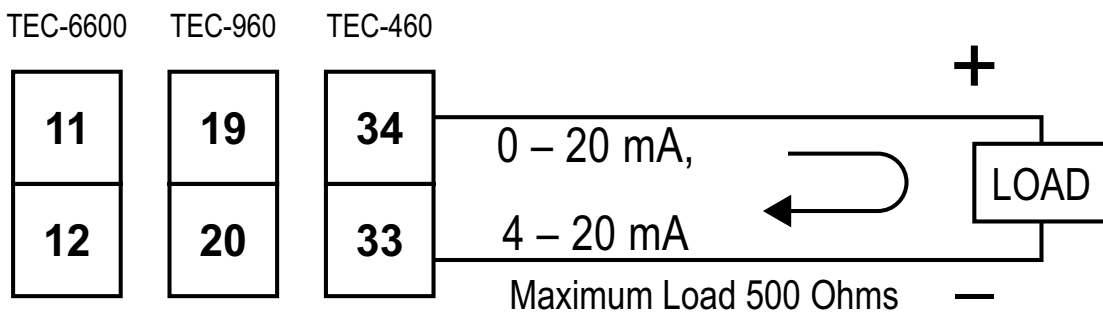

Figure 2-23 Retransmission Wiring - Current

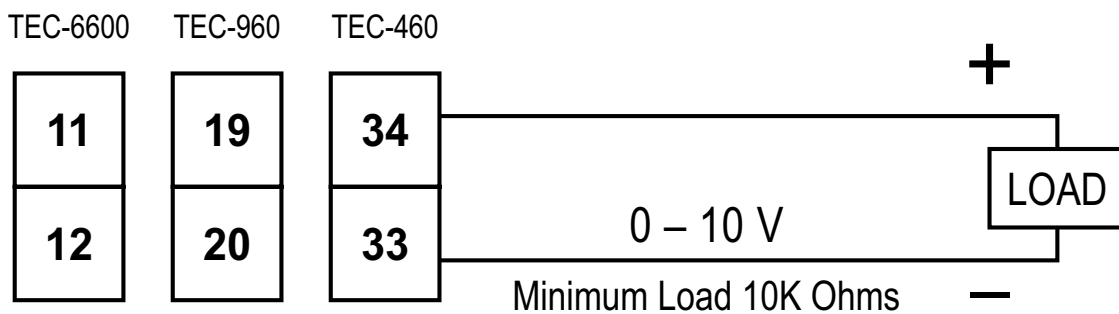

Figure 2-24 Retransmission Wiring - Voltage

2.11 RS-485 Data Communication

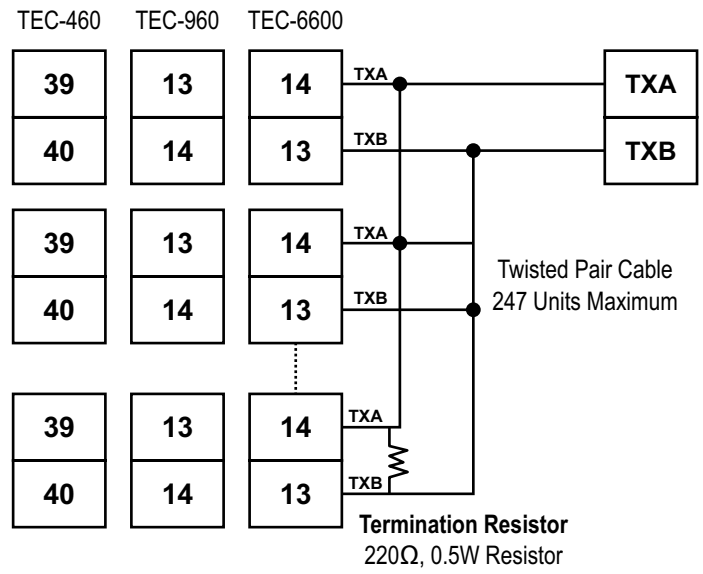





Figure 2-25 RS-485 Wiring

3 Programming

NOTE: Modbus Register Address Numbers are indicated by (*)

From the home screen, press  for 5 seconds and release to enter the setup menu, then press the  or  keys to navigate to the desired submenu. From there, press and release  to cycle through the parameters. The upper display indicates the parameter symbol, and the lower display indicates the value of the selected parameter. Refer to [“Menu Flowchart” on page 15](#) for instructions on navigating to a specific menu or parameter.

3.1 User Security

There are two parameters, **PASS** (85) for the password and **CODE** (87) for the security code, which control the data security function.

CODE Value	PASS Value	Access Rights
0	Any Value	All parameters are changeable
500	=500	All parameters are changeable
	≠500	All parameters are changeable except calibration parameters
1000	=1000	All parameters are changeable
	≠1000	User menu parameters only changeable
9999	=9999	All parameters are changeable except calibration parameters
	≠9999	HSP1 to HSP3 & LSP1 to LSP3 only changeable
Others	=CODE	All parameters are changeable
	≠CODE	No parameters can be changed

Table 3-1 User Access Rights

NOTE:

- If the user security is enabled, the controller will be automatically locked (*logout*) after a period of one minute idle time or when the power is disconnected. If the user needs to modify the parameters, then the user needs to configure **PASS=CODE** to login again.
- If the Remote Lock is function is used with event input, then the remote lock must be released to do changes on any of the parameters.
- The user needs to observe **CODE**, **PASS** logic for the remote lock operation. In addition, if remote is needed, it means the remote priority is higher than local. Local changes will be over-written by remote operations. If the code is equal to “0”, the remote **LOCK** feature won’t work.

3.2 Calibration Security

The calibration of the device is protected with separate security access. The parameters **KPAS** (86), the calibration password, and **KCOD** (88), the calibration security code, control the data security of calibration parameters.

When **KPAS = KCOD** the user can modify the calibration parameters.

KCOD Value	KPAS Value	Access Rights
KCOD	=KCOD	Calibration parameters are changeable
	≠KCOD	Calibration parameters can’t be changed

Table 3-2 Calibration Access Rights

3.3 Signal Input

INPT (6): Select the sensor type or signal type for signal input.

Range: (Thermocouple) J_tC, K_tC, T_tC, E_tC, B_tC, R_tC, S_tC, N_tC, L_tC, U_tC, P_tC, C_tC, d_tC

UNIT (7): Select the processing unit

Range: °C, °F, PU (Process unit). If the unit is neither °C nor °F, then selects PU.

DP (8): Select the resolution of the process value.

Range: For Thermocouple NO. DP, 1-DP and for Linear Signal NO. DP, 1-DP, 2-DP, 3-DP

3.4 Limit Control Output

Select the output 1 function and hysteresis in **OUT1** and **O1HY**.

OUT1 (17): The available output 1 functions are: High Limit Control, Low Limit Control and High & Low Limit Control. Refer to [“Limit Control Function” on page 4](#) for the limit control operation.

O1HY (18): Output 1 hysteresis value. The hysteresis value is adjusted to a proper value to eliminate the relay jitter in a noisy environment.

3.5 Set Point Range

The set point range can be configured with the following parameters.

HSPL (11): Lower limit of high limit set point **HSP1**. Hidden if **LO** is selected for **OUT1**.

HSP.H (12): Upper limit of high limit set point **HSP1**. Hidden if **LO** is selected for **OUT1**.

LSPL (13): Lower limit of low limit set point **LSP1**. Hidden if **HI** is selected for **OUT1**.

LSP.H (14): Upper limit of low limit set point **LSP1**. Hidden if **HI** is selected for **OUT1**.

HSPL and **HSP.H** in setup menu are used to confine the adjustment range of high limit set point

HSP1, **LSPL** and **LSP.H** are used to confine the adjustment range of low limit set point **LSP1**.

3.6 Alarm

The limit controller has up to three alarm outputs depending on the limit controller model. There are two types of alarm functions that can be selected for these alarms. There are six kinds of alarm modes available for each alarm function.

3.6.1 Alarm Types

There are two different types of alarms as listed below that the user can assign to different alarm outputs using **A1FN (20)**.

1. **PV. HI:** Process value high alarm

2. **PV. LO:** Process value low alarm

A process alarm can set two absolute trigger levels. When the process value is higher than **AxSP**, a **process high alarm (PV. HI)** occurs. The alarm is off when the process value is lower than **AxSP - AxHY**.

When the process value is lower than **AxSP**, a **process low alarm (PV. LO)** occurs. The alarm is off when the process is higher than **AxSP + AxHY**. A process alarm is independent of the set point.

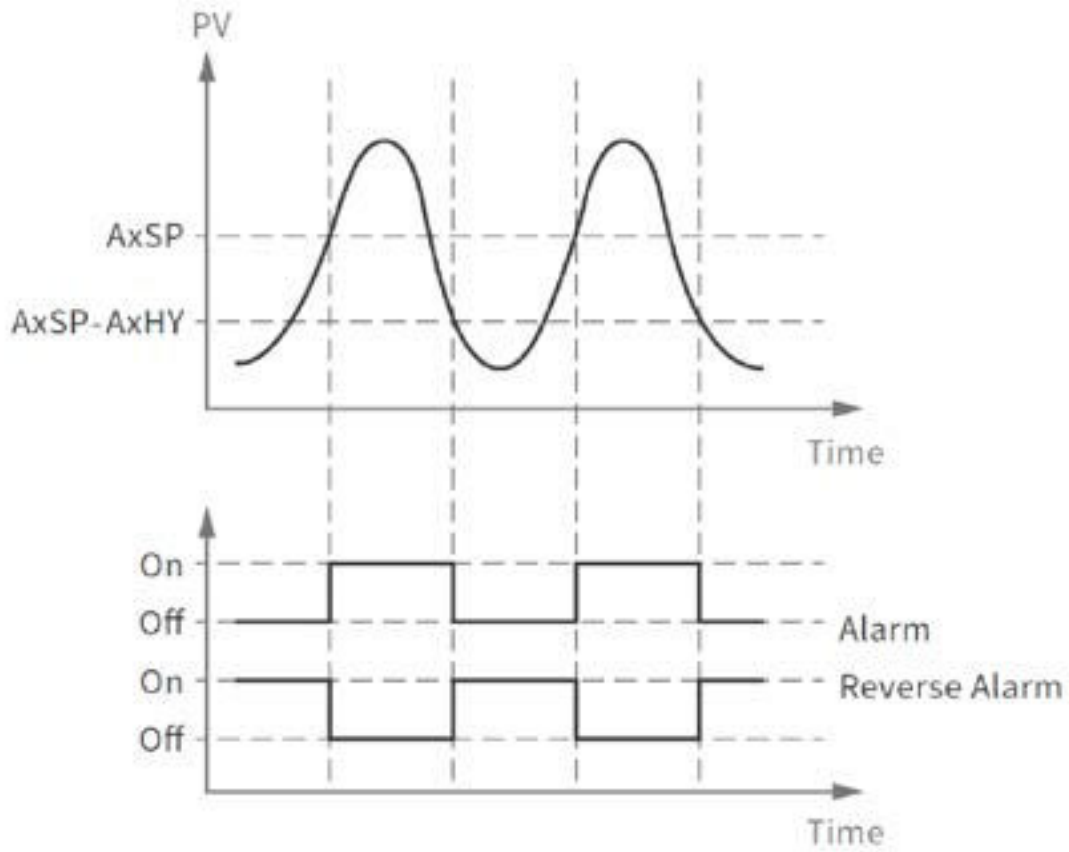

Figure 3-1 Process Value High (PV.HI)

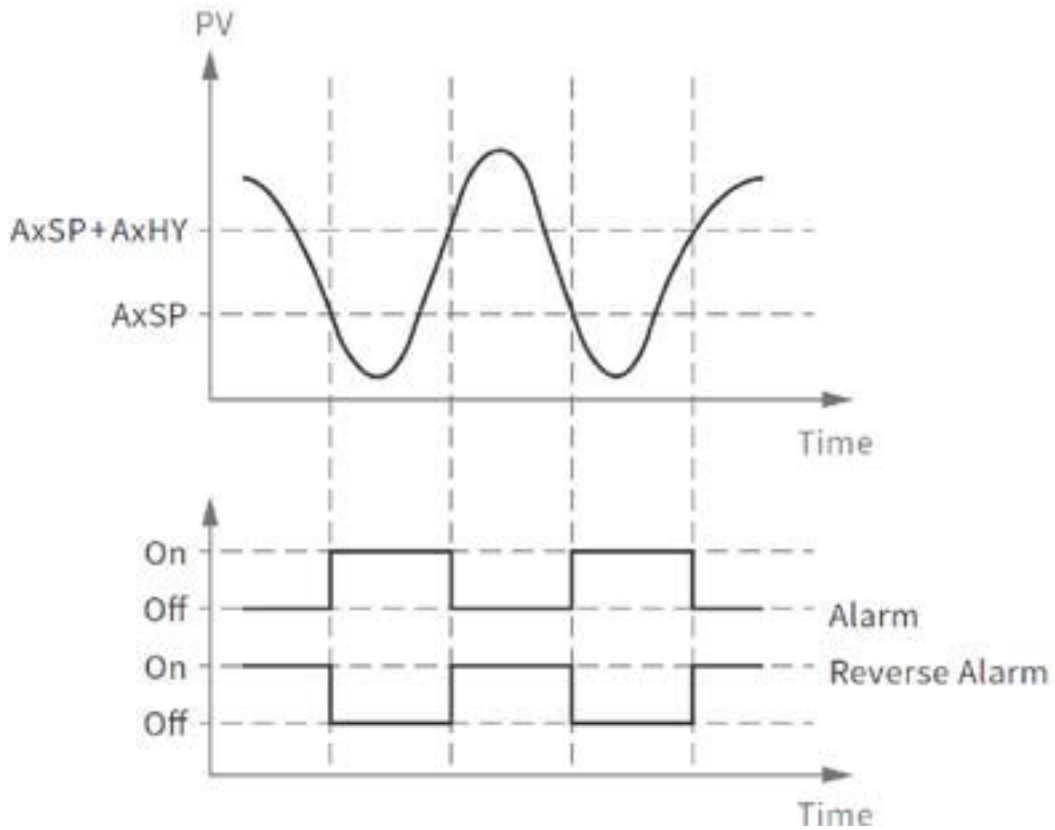

Figure 3-2 Process Value Low (PV.Lo)

3.6.2 Alarm Modes

There are four types of alarm modes available for each alarm function using **A1MD** (21).

1. Normal alarm
2. Latching alarm
3. Normal Alarm Reverse Output
4. Latching Alarm Reverse Output

3.6.2.1 *Normal Alarm: ALMD = NoRM*

When a normal alarm is selected, the alarm output is de-energized in the non-alarm condition and energized in an alarm condition.

3.6.2.2 *Latching Alarm: ALMD = LtCH*

If a latching alarm is selected, once the alarm output is energized, it will remain unchanged even if the alarm condition is cleared. The latching alarm can be reset by pressing the reset key once the alarm condition is removed.

3.6.2.3 *Normal Alarm Reverse Output: ALMD = NoR.R*

When a normal alarm reverse output is selected, the alarm output is energized in the non-alarm condition and de-energized in an alarm condition.

3.6.2.4 *Latching Alarm Reverse Output: ALMD = LtC.R*

If a latching alarm reverse output is selected, once the alarm output is de-energized, it will remain unchanged even if the alarm condition is cleared. The latching alarm can be reset (energized) by pressing the reset key once the alarm condition is removed.

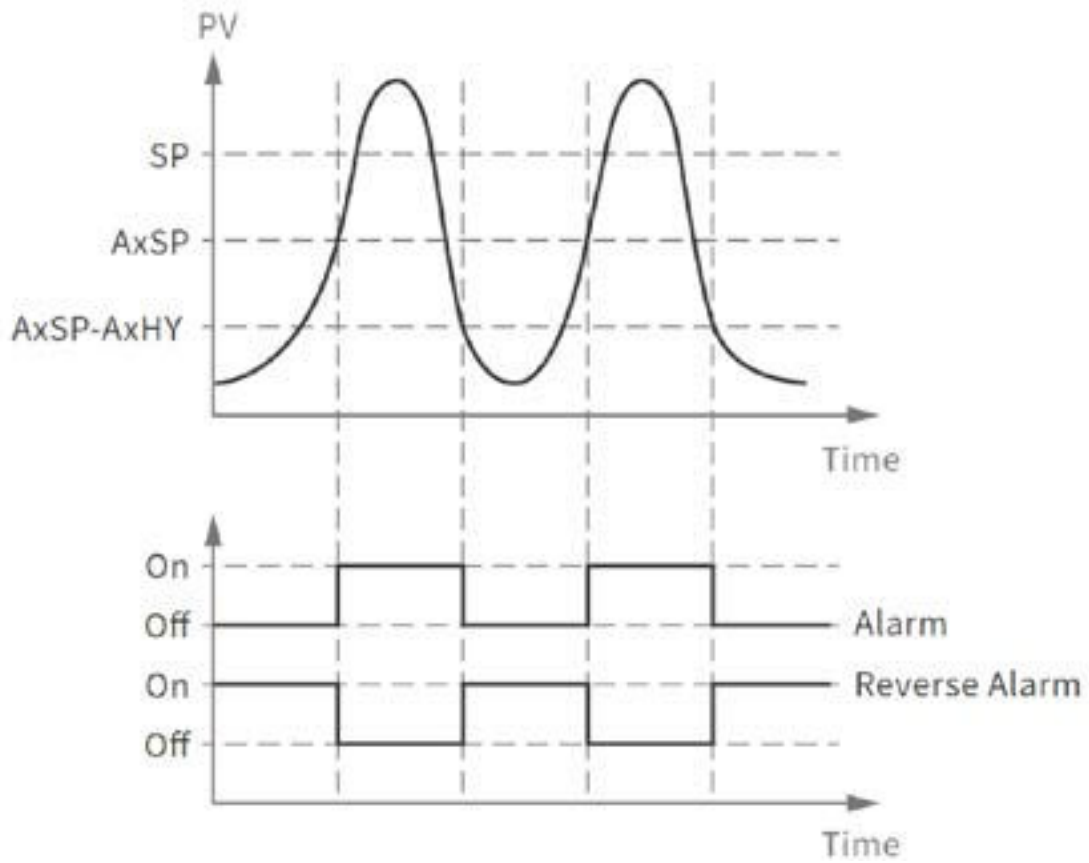

Figure 3-3 Process Value High - Normal Alarm

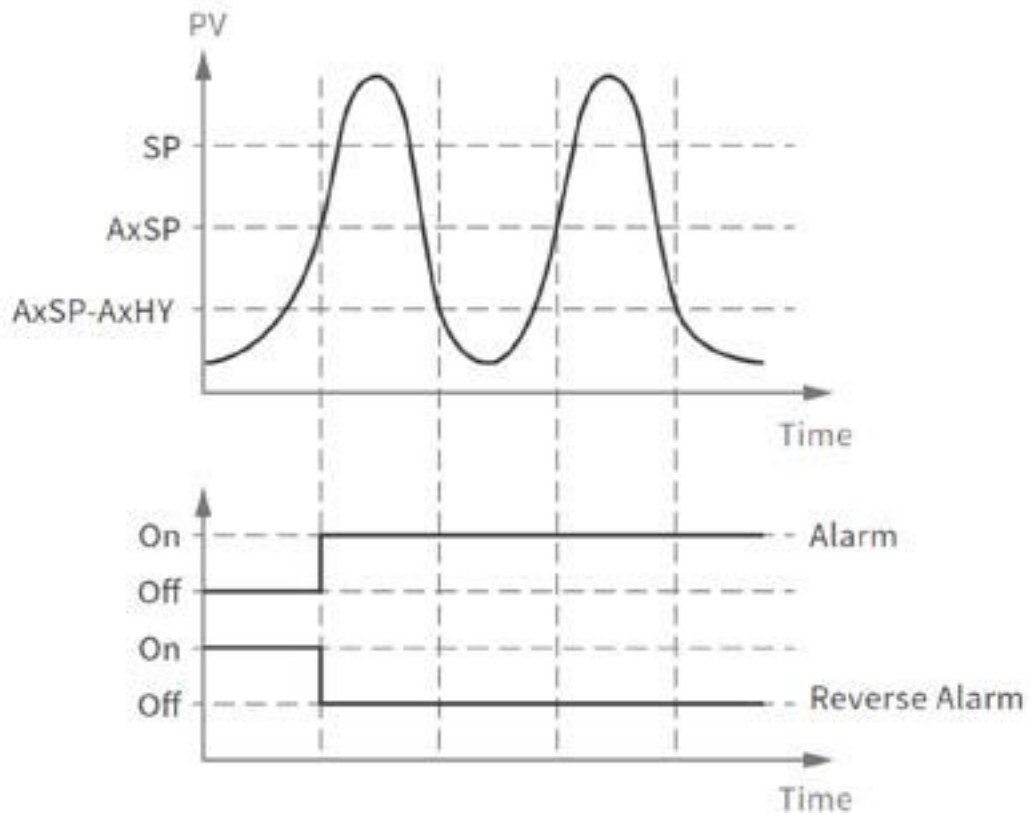

Figure 3-4 Process Value High - Latching Alarm

3.6.3 Alarm Failure Transfer

Alarm Failure transfer is activated as the unit enters failure mode. The respective Alarm will go on if **ON** is set for (23) **A1FT**, (28) **A2FT** or (33) **A3FT** and will go off if **OFF** is set for **A1FT**, **A2FT**, or **A3FT**. The unit will enter failure mode if a sensor break occurs or if the A-D converter fails.

3.7 User Select Menu Configuration

Conventional limit controllers are designed with parameters in a fixed order. If the user needs a friendlier menu operation to suit their application, most conventional limit controllers do not offer a solution. This series limit controllers have the flexibility for the user to select those parameters which are most significant and put these parameters in an easy access user menu.

There are 12 user-friendly parameters from the below list that can be set for user select menu configuration using the **SEL1-SEL5** (76-80) parameters.

- | | |
|-----------------------|--------------------|
| 0. NoNE: No Parameter | 7. OFTL: OFTL |
| 1. dISP: DISP | 8. OFTH: OFTH |
| 2. o1HY: O1HY | 9. CALO: CALO |
| 3. A1HY: A1HY | 10. CAHI: CAHI |
| 4. A1SP: A1SP | 11. A3HY: A3HY (*) |
| 5. A2HY: A2HY | 12. A3SP: A3SP (*) |
| 6. A2SP: A2SP | |

() TEC-960/TEC-460 Only*

When using the or key to select parameters, all of the above parameters may not be available. The number of visible parameters is dependent on the setup configuration.

3.8 User Calibration or PV Shift

Each unit is calibrated in the factory before shipment. The user can still modify the calibration in the field.

The basic calibration of the limit controller is highly stable and set for life.

User calibration allows the user to offset the permanent factory calibration to:

- Calibrate the limit controller to meet a user reference standard.
- Match the calibration of the limit controller to that of a particular transducer or sensor input.
- Calibrate the limit controller to suit the characteristics of a particular installation.
- Remove long term drift in the factory set calibration.

The parameters Offset Low **OFTL** (46) and Offset High **OFTH** (47) are used to make adjustments to correct an error in the process value.

The parameters **CALO** (48) and **CAHI** (49) are used as the input signal low and high values respectively.

To change the calibration, navigate to the calibration high/low parameter **OFTH/OFTL** found in the basic submenu **BASE** of the setup menu **SET**. Enter the high/low scale operating temperature in **CAHI/CALO** respectively, then press and release the key. If the PV on the

upper display differs from the input signal, press the Δ or ∇ keys to adjust the **OFTH/OFTL** value shown on the lower display until **PV** is equal to the value the user needs. Press and hold the \square key until the display blinks once to complete the high/low point calibration.

As shown below, the two points **OFTL** and **OFTH** construct a straight line. For accuracy, it is best to calibrate with the two points as far apart as possible. After the user calibration is complete, the input type will be stored in the memory. If the input type is changed, a calibration error will occur and an error code **CAER** is displayed.

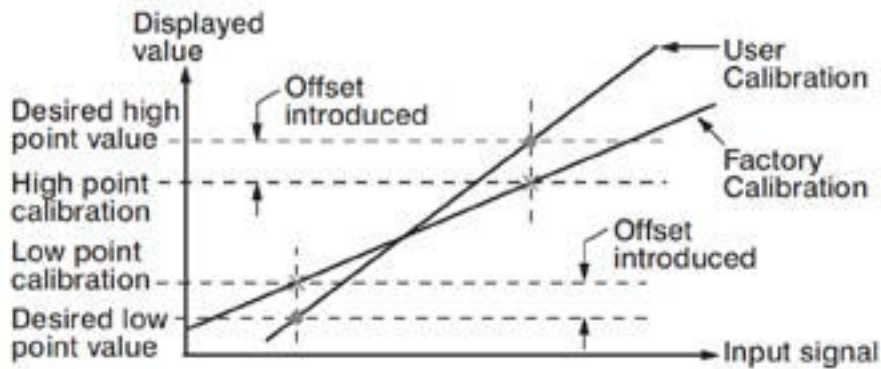

Figure 3-5 Two Point User Calibration

3.9 Digital Filter

In certain applications, the process value is too unstable to be read. To improve this, a programmable low pass filter incorporated in the limit controller can be used. This is a first-order filter with a time constant specified by the **FILT** (15) parameter. A value of 0.5 seconds is used as a factory default. Adjust **FILT** to change the time constant from 0 to 60 seconds. 0 seconds represents no filter applied to the input signal. The filter is characterized by the following diagram.

NOTE: The Filter is available only for the process value (PV) and is performed for the displayed value only. The limit controller is designed to use an unfiltered signal for control even when a filter is applied. If a lagged (filtered) signal is used for control, it may produce an unstable process.

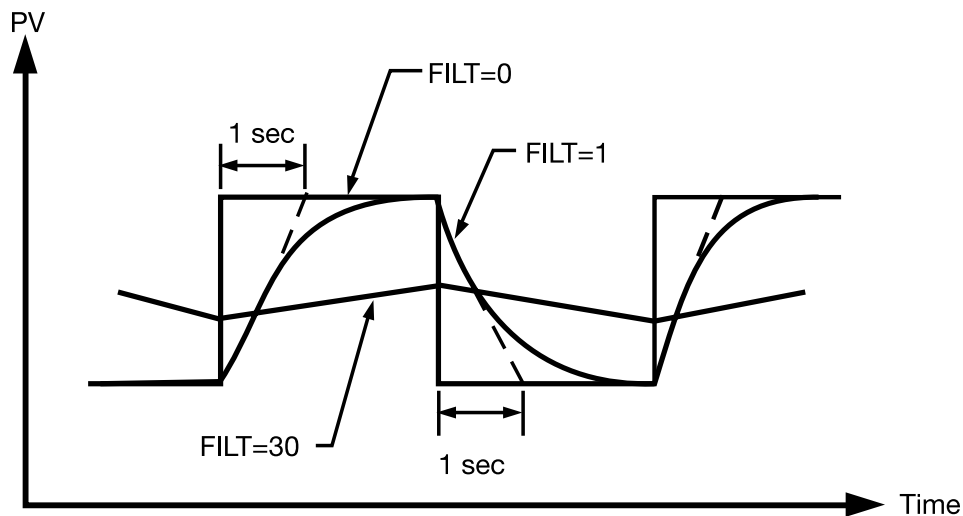





Figure 3-6 Filter Characteristics



3.10 Limit Annunciator

If **L_AN** (Limit annunciator) is selected for **OUT2** (19), the output 2 will act as a Limit Annunciator. If the limit is or has been reached and the reset  key (or remote reset contacts) have not been pressed since the limit was reached, then the limit annunciator output will be energized and the **OUT2** indicator will be lit and remain unchanged until the reset  key or remote reset input is applied.

3.11 Remote Reset

If **RRST** is selected for **E1FN** (38) or **E2FN** (39), the event input terminals will act as remote reset input. Pressing remote reset button will perform the same function as pressing the reset  key. Refer to [“Specifications” on page 5](#) for reset  key function.

3.12 Remote Lock

If **LOCK** is selected for **E1FN** (38) or **E2FN** (39), the event input terminals will act as remote lock input. Turning the remote lock switch on will keep all the parameter setting from been changed. If the switch is opened, the lock indicator is turn off and the  or  keys will be enabled. Depending on the user security configuration, the parameters can be changed.

NOTE: *The user needs to observe CODE, PASS logic for the remote lock operation. In addition, if remote is needed, it means the remote priority is higher than local. Local changes will be over-written by remote operations. If the code is equal to “0”, the remote LOCK feature won’t work.*

3.13 Power-Up Logic

Configurable power-up logic allows the user to change how the controller operates upon power-up. If power to the limit controller fails and power is reapplied, the controller goes through power up tests, then starts in one of the following configurable conditions configured in the **PWRU** (133) parameter.

- 0. NoRM (Normal):** After power down, the controller will operate normally in the same mode as before power was removed unless a limit has been exceeded after power up.
- 1. RST (Reset):** After power down, the controller latching relay will have to be reset using the reset  key or digital (event) input option. The unit must be reset even if the device was not in a limit condition before power down. It must also be reset even if the device is not in a limit condition after power-up.

NOTE: *As the user needs to reset the unit by using the reset  key or a digital (event) input, the annunciator output will not be activated at the power on stage at Reset Mode.*

- 2. NoRL (Normal Latch):** After power down, the controller will operate normally in the same mode as before power was removed unless a limit has been exceeded upon power-up. If the limit was latched at power down, the unit will be in “Limit” at power-up and have to be reset.

3.14 Reference Data

The setup menu SET contains three read-only reference data parameters. These are:

PV.HI (67): The maximum historical **PV**, which shows the maximum process value since the last **UNLOCK** operation.

PV.LO (68): The minimum historical **PV**, which shows the minimum process value since the last **UNLOCK** operation.

T.ABN (63): The abnormal time, which shows the total accumulated time in minutes that the process has been in abnormal condition since the last **UNLOCK** operation.

The values of reference data will be initiated as soon as the reset **[R]** key is pressed for 4 seconds (**UNLOCK** operation). After an **UNLOCK** operation, the **PV.HI** and **PV.LO** values will start from the current process value and **T.ABN** value will start from zero.

3.15 Failure Transfer

The limit controller will enter failure mode if one of the following conditions occurs:

1. An **SBER** error occurs due to an input sensor break.
2. An **ADER** error occurs due to the A-D converter of the limit controller fails. Output 1 will perform the failure transfer function as the limit controller enters failure mode.

3.15.1 Output 1 Failure Transfer

If Output 1 Failure Transfer is activated, it will perform like the limit controller is in abnormal condition.

3.15.2 Alarm Failure Transfer

An alarm failure transfer is activated as the limit controller enters failure mode. After that, the alarm output will transfer to the **ON** or **OFF** state which is determined by the set value of **A1FT**, **A2FT** and **A3FT**.

3.16 Data Communication

The limit controllers support RS-485 Modbus RTU protocol for data communication. Using a PC for data communication is the most economical way. The signal is transmitted and received through the PC communication Port. Since a standard PC can't support an RS-485 port, a network adaptor such as an RS232 to RS485 Converter or USB to Serial Converter must be used to convert RS-485 to RS-232 or USB for a PC. Many RS-485 units (up to 247 units) can be connected to one RS-232 port or USB Port. Therefore, a PC with 4 comm. ports can communicate with up to 988 units. It is quite economical.

For more information on Data Communication, refer to [“Communication” on page 62.](#)

3.16.1 RS-485 Setup

- Enter the setup menu.
- Set individual addresses for units connected to the same port.
- Set the Baud Rate (**BAUD**), Data Bit (**DATA**), Parity Bit (**PARI**) and Stop Bit (**STOP**) such that these values are accordant with PC setup conditions.

3.17 Retransmission

Using **RETY** (40) the limit controller can output (retransmit) **PV** or **HSP** or **LSP** via its retransmission terminals RE+ and RE, provided that the retransmission option is ordered. A correct signal type should be selected for the option board to meet the retransmission option installed. **RELO** (41) and **REHI** (42) are adjusted to specify the low scale and high scale values of retransmission.

3.18 Event Input

There are a maximum of two event inputs available in this series of limit controllers. Refer to [“Event Input Wiring” on page 44](#) for wiring an event input. The event input accepts a digital (on/off) type signal.

Types of signals that can be used to switch the event input are listed below:

- Relay
- Switch contacts
- Open collector Pull Low
- TTL logic level

One of the functions in the following list can be chosen by using **EIFN1** (38) and **EIFN2** (39) contained in the setup menu **SET**. The same function cannot be set to more than one event input.

NOTE: *The limit controller must have the respective event input on the limit controller hardware to select any of the event input functions listed in the following section, other than NoNE in E1FN or E2FN. Otherwise the limit controller may malfunction.*

3.18.1 Event Input Functions

- **NoNE:** none
- **LOCK:** Remote Lock. If **LOCK** is selected for **E1FN** or **E2FN**, the event input terminals will act as remote lock input. Turning the remote lock switch on will keep all the parameter setting from been changed depends on the user security configuration. If the switch is opened, the lock indicator is extinguished and the or keys are enabled.
- **RRST:** Remote Reset for Output1. If **RRST** is selected for **E1FN** or **E2FN**, the event input terminals will act as remote reset input. Pressing remote reset button will perform the same function as pressing the reset key.
- **HSP2:** **HSP2** activated to replace **HSP1**.
- **LSP2:** **LSP2** activated to replace **LSP1**.
- **HLS2:** **HSP2** & **LSP2** activated to replace **HSP1** & **LSP1**.
- **HSP3:** **HSP3** activated to replace **HSP1**.
- **LSP3:** **LSP3** activated to replace **LSP1**.
- **HLS3:** **HSP3** & **LSP3** activated to replace **HSP1** & **LSP1**.
- **RS.A1:** Reset Alarm 1 as the event input is activated. However, if the alarm condition still exists, the alarm will remain on even though the event input is triggered.
- **RS.A2:** Reset Alarm 2 as the event input is activated. However, if the alarm condition still exists, the alarm will remain on even though the event input is triggered.
- **RS.A3:** Reset Alarm 3 as the event input is activated. However, if the alarm condition still exists, the alarm will remain on even though the event input is triggered.
- **RS.AO:** Reset all alarms as the event input is activated. However, if the alarm condition still exists, the alarm will remain on even though the event input is triggered.
- **CA.LH:** Cancel the latched alarm as the event input is activated. However, if the alarm condition still exists, the alarm will remain on even though the event input is triggered.
- **R.REF:** Reset Reference Data **PV.HI**, **PV.LO** and **T.ABN**.

4 Applications

4.1 Limit Controller Application Wiring

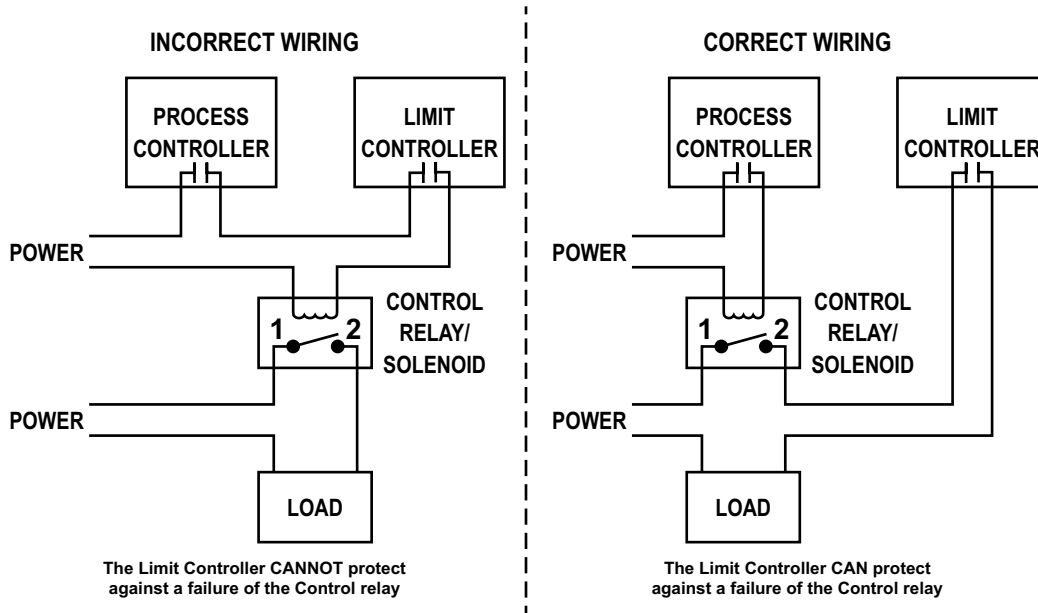

Figure 4-1 Limit Controller Application Wiring

4.2 High Temperature Protection with Remote Reset

An oven uses a single-phase heater to heat the process. A single loop temperature control TEC-9400 is used to regulate the temperature. A limit control TEC-960 is used to protect the process from being over heated. The wiring diagram is shown below.

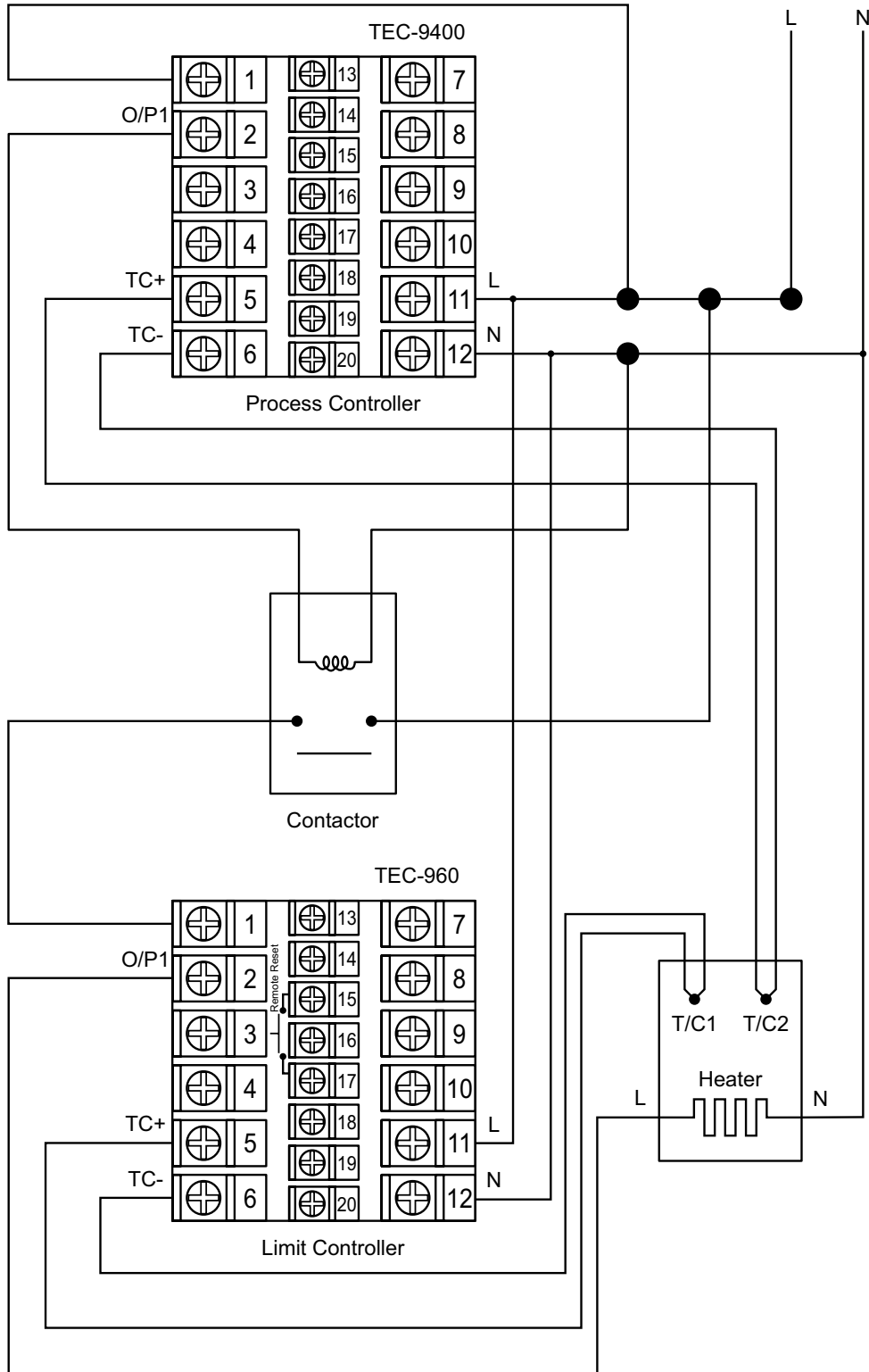

Figure 4-2 High Temperature Protection With Remote Reset

5 Calibration

NOTE: *Warranty may be voided if parameters have been changed*

⚠ Do not proceed through this section unless there is a definite need to recalibrate the limit controller. All previous calibration data will be lost. Do not attempt recalibration unless you have appropriate calibration equipment. If calibration data is lost, you will need to return the limit controller to your supplier who may charge you a service fee to recalibrate the limit controller.



⚠ Entering the calibration mode will break the limit control loop. Make sure that the system is able to apply the calibration mode.

5.1 Equipment Required Before Calibration





1. A high accuracy calibrator (Fluke 5520A Calibrator recommended) with the following functions:
 - 0 - 100 mV millivolt source with 0.005 % accuracy
 - 0 - 10 V voltage source with 0.005 % accuracy
 - 0 - 20 mA current source with 0.005 % accuracy
 - 0 - 300Ω resistant source with 0.005 % accuracy
2. A test chamber providing 25°C - 50°C temperature range
3. A switching network (SWU16K, optional for automatic calibration)
4. A calibration fixture equipped with programming units (optional for automatic calibration)
5. A PC installed with calibration software (optional for automatic calibration)

The calibration procedures described in the following section are step by step manual procedures. Since a limit controller needs 30 minutes to warm up before calibration, calibrating the units one by one is quite inefficient. An automatic calibration system for small quantity as well as for an unlimited quantity is available upon request.





5.1.1 Manual Calibration Procedure

Set the Lock parameter to the unlocked condition (**CODE** = 0). Press and hold the scroll  key until **CALI** appears on the display, then release the scroll  key. Press the scroll  key for 2-3 seconds then release, the display will show **AD.LO** (51) and the unit will enter the calibration mode.

5.1.1.1 Calibrate Zero of A to D Converter

Short the thermocouple input terminals (TC+, TC-) and select the input type as K type Thermocouple in the **INPT** (6) parameter in the **BASE** submenu. Press and hold the scroll  key until **CALI** appears on the display, then release the scroll  key. Press the scroll  key for 2-3 seconds then release, the display will show **AD.LO** (51) and the unit will enter calibration mode. Then press the scroll  key for at least 5 seconds. The display will blink a moment and a new value is obtained. If the display didn't blink or the obtained value is equal to -199.9 or 199.9, then the calibration failed.

5.1.1.2 Calibrate Gain of A to D Converter

Select the input type as K type Thermocouple in the **INPT** (6) parameter in the **BASE** submenu. Press and hold the scroll  key until **CALI** appears on the display, then release the scroll  key. Press the scroll  key for 2-3 seconds then release, the display will show **AD.LO** (51) and the unit will enter calibration mode. Press the scroll  key to navigate to **AD.HI** (52). Send a 60-mV signal to the thermocouple input terminals with the correct polarity. Press the scroll  key for at least 5 seconds. The display will blink a moment and a new value is obtained. If the display didn't blink or the obtained value is equal to -199.9 or 199.9, then the calibration fails.

5.1.1.3 Calibrate Offset of Cold Junction Compensation

Setup the equipment according to the following diagram for calibrating the cold junction compensation. Note that a K type thermocouple must be used.

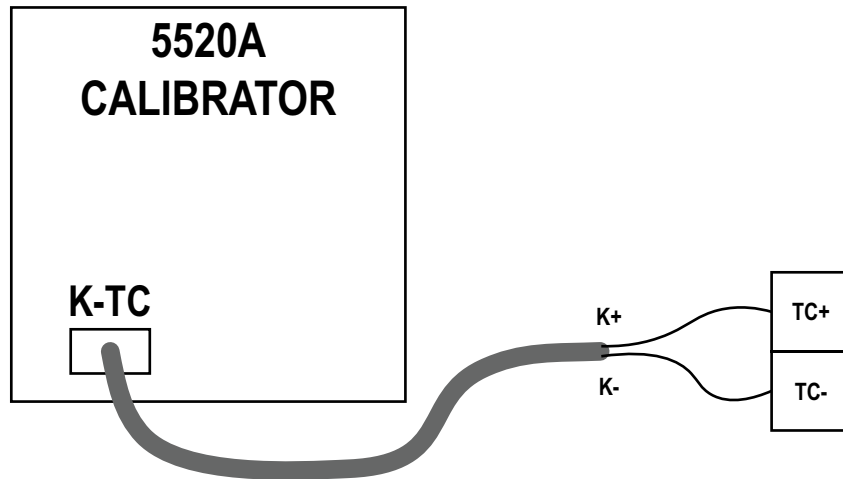









Figure 5-1 Cold Junction Calibration Setup





Let the limit controller sit at least 20 minutes in a room temperature of $25 \pm 3^\circ\text{C}$. The 5520A calibrator is to be configured as a K type thermocouple output with internal compensation. Send a 0.00°C signal to the limit controller.

Select the input type as K type Thermocouple in the **INPT** (6) parameter in the **BASE** submenu.. Press and hold the scroll  key until **CALI** appears on the display, then release the scroll  key. Press the scroll  key for 2-3 seconds then release, the display will show **AD.LO** (51) and the unit will enter calibration mode. Press the scroll  key to navigate to **CJ.LO** (55). Press the  or  key to set the value to 40.00. Press the scroll  key for at least 5 seconds. The display will blink a moment and a new value is obtained. If the display didn't blink or the obtained value is equal to 5.00 or 40.00, then the calibration failed.

5.1.1.4 Calibrate Gain of Cold Junction Compensation





Setup the equipment the same as during Offset calibration of Cold Junction Compensation. The unit under calibration is to be powered in a room with a temperature of $50 \pm 3^\circ\text{C}$ for at least 20 minutes. The calibrator source is to be set to 0.00°C with internal compensation mode.



Select the input type as K type Thermocouple in the **INPT** (6) parameter in the **BASE** submenu. Press and hold the scroll  key until **CALI** appears on the display,

then release the scroll  key. Press the scroll  key for 2-3 seconds then release, the display will show **AD.LO** (51) and the unit will enter calibration mode. Press the scroll  key to navigate to **CJ.HI** (56). Press the scroll  key for at least 5 seconds. The display will blink a moment and a new value is obtained. If the display didn't blink or the obtained value is equal to -199.9 or 199.9, then the calibration failed.





This setup is performed in a high-temperature chamber; hence it is recommended to use a computer to perform the procedures



5.1.1.5 Calibrate RTD Input





Select the input type as PT100 RTD in the **INPT** (6) parameter in the **BASE** submenu. Press and hold the scroll  key until **CALI** appears on the display, then release the scroll  key. Press the scroll  key for 2-3 seconds then release, the display will show **AD.LO** (51) and the unit will enter calibration mode. Press the scroll  key to navigate to **RTDL** (53). Send a 100 Ω signal to the RTD input terminals (PTA, PTB, PTB) according to the connection. Press the scroll  key for at least 5 seconds. The display will blink a moment, otherwise, the calibration failed.



Press the scroll  key and the display will navigate to **RTDH** (54). Change the resistance value to 300 Ω . Press the scroll  key for at least 5 seconds. The display will blink a moment and two values are obtained for **RTDH** and **RTDL**. If the display didn't blink or the obtained value is equal to -199.9 or 199.9, then the calibration failed.

5.1.1.6 Calibrate Linear Input

Select the input type as 0 to 10V in the **INPT** (6) parameter in the **BASE** submenu. Press and hold the scroll  key until **CALI** appears on the display, then release the scroll  key. Press the scroll  key for 2-3 seconds then release, the display will show **AD.LO** (51) and the unit will enter calibration mode. Press the scroll  key to navigate to **V1L** (57). Send a 0V signal to the V+ and V- terminals. Press the scroll  key for at least 5 seconds. The display will blink for a moment and a new value is obtained. If the display did not blink or the obtained value is equal to -199.9 or 199.9, the calibration failed.

Press the scroll  key and the display will navigate to **V1G** (58). Send a 10V signal to the V+ and V- terminals. Press the scroll  key for at least 5 seconds. The display will blink a moment and a new value is obtained. If the display did not blink or the obtained value is equal to -199.9 or 199.9, the calibration failed.

Select the input type as 0 to 20mA in the **INPT** (6) parameter in the **BASE** submenu. Press and hold the scroll  key until **CALI** appears on the display, then release the scroll  key. Press the scroll  key for 2-3 seconds then release, the display will show **AD.LO** (51) and the unit will enter calibration mode. Press the scroll  key to navigate to **MA1L** (59). Send a 0mA signal to the mA+ and mA- terminals. Press the scroll  key for at least 5 seconds. The display will blink a moment and a new value is obtained. If the display did not blink or the obtained value is equal to -199.9 or 199.9, the calibration failed.

Press the scroll  key and the display will navigate to **MA1G** (60). Send a 20mA signal to the mA+ and mA- terminals. Press the scroll  key for at least 5 seconds. The display will blink for a moment and a new value is obtained. If the display did not blink or the obtained value is equal to -199.9 or 199.9, the calibration failed.

6 Communication

This chapter explains the Modbus Communication protocol of the limit controller using RS-485 communication. For wiring of the RS-485, refer to [“RS-485 Data Communication” on page 45.](#) This supports only RTU mode. Data is transmitted as 8-bit binary bytes with 1 start bit, 1 stop bit and optional parity checking (None, Odd, Even). Baud rate may be set to 2400, 4800, 9600, 14400, 19200, 28800, 38400, 57600 and 115200 BPS.

6.1 Functions Supported

Only function code 03, 06 and 16 are available for this series of limit controllers. The message formats for each function code are described as follows.

6.1.1 Function Code 03: Read Holding Registers

Query (From Primary)	Secondary Address (1~247)	Response (From Secondary)	Secondary Address (1~247)
	Function Code (03)		Function Code (03)
	Starting Address of Register Hi (00)		Byte Count
	Starting Address of Register Lo (00~49, 51~88, 128~132, 139, 140, 142, 143)		Data1 Hi
	No of Words Hi (00)		Data1 Lo
	No of Words Lo (1~81)		Data2 Hi
	CRC16 Hi		Data2 Lo
	CRC16 Lo		...
			Data 'n' Hi
	Data 'n' Lo		
	CRC16 Hi		
	CRC16 Lo		

6.1.2 Function Code 06: Pre-Set Single Register

Query (From Primary)	Secondary Address (1~247)	Response (From Secondary)	Secondary Address (1~247)
	Function Code (06)		Function Code (06)
	Starting Address of Register Hi (00)		Starting Address of Register Hi (00)
	Starting Address of Register Lo (00~49, 51~88, 128~132, 139, 140, 142, 143)		Starting Address of Register Lo (00~49, 51~88, 128~132, 139, 140, 142, 143)
	Data Hi		Data Hi
	Data Lo		Data Lo
	CRC16 Hi		CRC16 Hi
	CRC16 Lo		CRC16 Lo

6.1.3 Function Code 16: Pre-set Multiple Register

Query (From Primary)	Secondary Address (1~247)	Response (From Secondary)	Secondary Address (1~247)
	Function Code (16)		Function Code (16)
	Starting Address of Register Hi (00)		Starting Address of Register Hi (00)
	Starting Address of Register Lo (00~49,51~88,128~132,139,140,142,143)		Starting Address of Register Lo (00~49,51~88,128~132,139,140,142,143)
	No of Words Hi (00)		No of Words Hi (00)
	No of words Lo (1~81)		No of words Lo (1~81)
	Bytes Count (2~162)		Bytes Count (2~162)
	Data1 Hi		Data1 Hi
	Data1 Lo		Data1 Lo
	Data2 Hi		Data2 Hi
	Data2 Lo		Data2 Lo

	Data 'n' Hi		Data 'n' Hi
	Data 'n' Lo		Data 'n' Lo
CRC16 Hi	CRC16 Hi		
CRC16 Lo	CRC16 Lo		

6.2 Exception Responses

If the limit controller receives a message which contains a corrupted character (parity check error, framing error etc.), or if the CRC16 check fails, the limit controller ignores the message. However, if the limit controller receives a syntactically correct message which contains an illegal value, it will send an exception response, consisting of five bytes as follows:

Secondary address + offset function code + exception code + CRC16 Hi + CRC16 Lo

The offset function code is obtained by adding the function code with 128 (i.e. function 3 becomes H'83), and the exception code is equal to the value contained in the following table.

Exception Code	Description	Reason
1	Bad Function Code	The function code is not supported by the limit controller
2	Illegal Data Addresses	Register address out of range
3	Illegal Data Value	Data value out of range or attempt to write a read-only or protected data

Table 6-1 Exception Code

6.3 Parameter Mapping

The parameter mapping of Modbus address is available in the [“Parameter Availability Table \(Modbus Addresses\)”](#) on page 20.

6.4 Error Codes

Error Code	Display Symbol	Description & Reason	Corrective Action
10	ER10	Communication error: bad function code	Correct the communication software to meet the protocol requirements
11	ER11	Communication error: register address out of range	Do not issue an over-range address of the register to the Secondary
14	ER14	Communication error: attempt to write a read-only data	Do not write read-only data or protected data to the Secondary
15	ER15	Communication error: write a value which is out of range to a register	Do not write an over-range data to the Secondary register
16	EIER	Event Input Error: Two or more event inputs are set to the same function	Do not set the same function in two Event Input Function parameters (E1FN and E2FN)
29	EEPR	EEPROM can't be written correctly	Cannot be repaired.
30	CJER	Cold junction compensation for Thermocouple malfunction	Cannot be repaired.
39	SBER	Input sensor break, or input current below 1 mA if 4-20 mA is used, or input voltage below 0.25V if 1 - 5V is used	Replace the input sensor.
40	ADER	A to D converter or related component(s) malfunction	Cannot be repaired.

6.5 Mode

The Value of the Mode Register is as below.

Value	H'000X	H'010X	H'040X	H'0X00	H'0x01
Mode	Normal mode	Calibration mode	Failure mode	Alarm status is off	Alarm status is on

Table 6–2 Operation Mode

Bit wise description of Mode register value is as below.

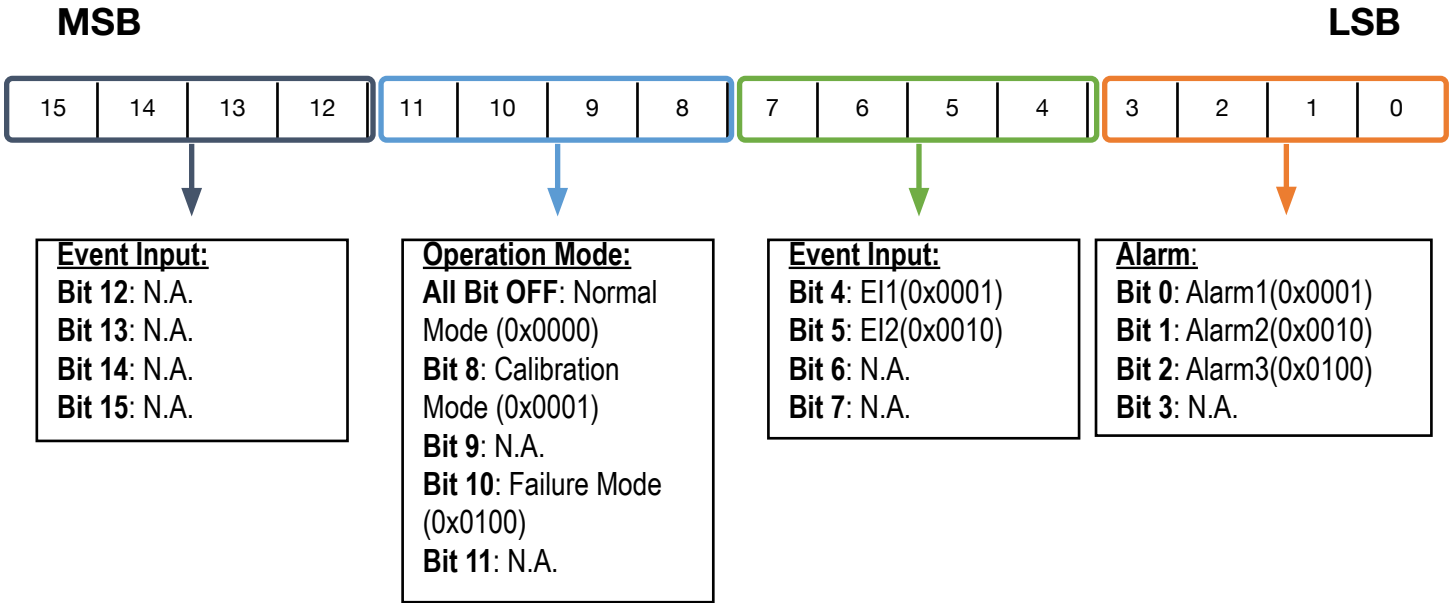

6.6 PROG Code

The Program Code is defined in the table below.

Program Code	Model No
26.XX	TEC-6600
64.XX	TEC-960
45.XX	TEC-460

Table 6–3 Program Code

6.7 Scaling

The values stored in registers are based on 2's complement format. The relation between the value of number in register and its actual value is shown in the following table.

Data in Register	65535	65534	50000	32769	32768	32767	10000	1000
Actual Value	-1	-2	-15536	-32767	-32768	32767	10000	1000

Table 6–4 Data Conversion

6.8 Communication Examples

6.8.1 6Read PV

Send the following command to the limit controller via the communication port

	03	00	H'40	00	01	HI	LO
Secondary Address	Function Code	Starting Address		No of Words		CRC16	

6.8.2 Perform Reset Function (same effect as pressing the R key)

	06	00	H'48	H'68	H'25	HI	LO
Secondary Address	Function Code	Register Address		Data Hi/Lo		CRC16	

6.8.3 Read All Parameters

	03	00	00	00	H'50	HI	LO
Secondary Address	Function Code	Starting Address		No of Words		CRC16	

6.8.4 Calibrate ADLO

	H'10	00	H'48	00	02	04	H'68	H'29	00	H'33	HI	LO
Secondary Address	Function Code	Register Address		No of Words		Bytes Count	Data Hi/Lo		Data Hi/Lo		CRC16	

6.8.5 Command Mode

The command and job1 register values are as below for different modes.

Command Mode Value		Command Mode	Description	Job1 Value			Function Code	
Dec	Hex				Dec	Hex	06	16
26668	282C	Unlock.	Temporarily unlocked. CMND will hold the "PASLOCK" value of 26668(0x682C) until other CMND value is set or 180 seconds.	✓	✓
26664	6829	Calibration Mode	Calibrate ADLO	ADLO	51	0033		✓
			Calibrate ADHI	ADHI	52	0034		✓
			Calibrate RTDL	RTDL	53	0035		✓
			Calibrate RTDH	RTDH	54	0036		✓
			Calibrate CJLO	CJLO	55	0037		✓
			Calibrate CJHI	CJHI	56	0038		✓
			Calibrate V1L	V1L	57	0039		✓
			Calibrate V1G	V1G	58	003A		✓
			Calibrate MA1L	MA1L	59	003B		✓
		Calibrate MA1G	MA1G	60	003C		✓	
2661	6825	Reset	Same action as the Reset Key	✓	✓

Returns

No product returns can be accepted without a completed Return Material Authorization (RMA) form.

Technical Support

Technical questions and troubleshooting help is available from Tempco. When calling or writing, please give us as much background information on the application or process as possible.

Email: techsupport@tempco.com

Phone: 630-350-2252
800-323-6859

Note: Information in this manual was deemed correct at the time of printing. The policy of Tempco is one of continuous development and product improvement, and we reserve the right to modify specifications and designs without prior notice. Not responsible for typographical errors.

Custom Manufacturer Since 1972

ELECTRIC HEATING ELEMENTS • TEMPERATURE CONTROLS • SENSORS • PROCESS HEATING SYSTEMS

HEAT THINGS UP!

With Thousands of Design Variations
We Make Everything You Need.

Band Heaters
Cast-In Heaters
Radiant Heaters
Flexible Heaters
Process Heaters
Temperature Control

Cartridge Heaters
Coil & Cable Heaters
Strip Heaters
Tubular Heaters
Instrumentation
Temperature Sensors



607 N. Central Avenue Wood Dale, IL 60191-1452 USA
P: 630-350-2252 Toll Free: 800-323-6859
F: 630-350-0232 E: info@tempco.com
www.tempco.com