

TEMPCO®

USER MANUAL

TEC-220 & TEC-920

Auto-Tune PID Process
Temperature Controller



Warning Symbol

This symbol calls attention to an operating procedure, practice, or the like which, if not correctly performed or adhered to, could result in personal injury or damage to or destruction of part or all of the product and system. Do not proceed beyond a warning symbol until the indicated conditions are fully understood and met.

Using the Manual

- Installers Read Chapter 1, 2
- System Designer Read All Chapters
- Expert User Read Page 11

Contents

	Page Number
Chapter 1 Overview	
1-1 General	1
1-2 Hardware Code	2
1-3 Programming Port	2
1-4 Keys and Displays	3
1-5 Menu Overview	4
1-6 Parameter Descriptions	5
Chapter 2 Installation	
2-1 Unpacking	7
2-2 Mounting	7
2-3 Wiring Precautions	7
2-4 Power Wiring	8
2-5 Sensor Installation Guidelines	8
2-6 Sensor Input Wiring	8
2-7 Control Output Wiring	8
2-8 Alarm Wiring	10
2-9 Data Communication	10
Chapter 3 Programming	
3-1 Lockout	11
3-2 Signal Input	11
3-3 Control Outputs	11
3-4 Alarm	13
3-5 Configuring the Display	14
3-6 Ramp	14
3-7 Dwell Timer	14
3-8 PV Shift	15
3-9 Digital Filter	15
3-10 Failure Transfer	15
3-11 Auto-tuning	16
3-12 Manual tuning	16
3-13 Manual Control	17
3-14 Data communication	17
3-15 Process Variable (PV) Retransmission	17
Chapter 4 Applications	
4-1 Heat Only Control With Dwell Timer	18
4-2 Cool Only Control	18
4-3 Heat-Cool Control	19
Chapter 5 Not Applicable	—
Chapter 6 Specifications	20
Chapter 7 Modbus Communications	
7-1 Functions Supported	22
7-2 Exception Responses	23
7-3 Parameter Table	23
7-4 Data Conversion	25
7-5 Communication Examples	26

NOTE:

It is strongly recommended that a process should incorporate a **LIMIT CONTROL** like **TEC-910** which will shut down the equipment at a preset process condition in order to preclude possible damage to products or system.

Information in this user's manual is subject to change without notice.

Copyright © 2021, Tempco Electric Heater Corporation, all rights reserved. No part of this publication may be reproduced, transmitted, transcribed or stored in a retrieval system, or translated into any language in any form by any means without the written permission of Tempco Electric Heater Corporation.

Figures & Tables

	Page Number
Figure 1.1 Fuzzy Control Advantage	1
Figure 1.2 Programming Port Overview	2
Figure 1.3 Front Panel Description	3
Figure 1.4 Display in Initial Stage	3
Figure 2.1 Mounting Dimensions and Panel Cutout	7
Figure 2.2 Lead Termination for TEC-920	7
Figure 2.3 Lead Termination for TEC-220	7
Figure 2.4 Rear Terminal Connection for TEC-220	8
Figure 2.5 Rear Terminal Connection for TEC-920	8
Figure 2.6 Power Supply Connections	8
Figure 2.7 Sensor Input Wiring	8
Figure 2.8 Output 1 Relay or Triac (SSR) to Drive Load	8
Figure 2.9 Output 1 Relay or Triac (SSR) to Drive Contactor	8
Figure 2.10 Output 1 Pulsed Voltage to Drive SSR	9
Figure 2.11 Output 1 Linear Current	9
Figure 2.12 Output 1 Linear Voltage	9
Figure 2.13 Output 2 Relay or Triac (SSR) to Drive Load	9
Figure 2.14 Output 2 Relay or Triac (SSR) to Drive Contactor	9
Figure 2.15 Output 2 Pulsed Voltage to Drive SSR	9
Figure 2.16 Output 2 Linear Current	9
Figure 2.17 Output 2 Linear Voltage	9
Figure 2.18 Alarm Output to Drive Load	10
Figure 2.19 Alarm Output to Drive Contactor	10
Figure 2.20 RS-485 Wiring	10
Figure 2.21 RS-232 Wiring	10
Figure 2.22 Configuration of RS-232 Cable	10
Figure 3.1 Conversion Curve for Linear Type Process Value	11
Figure 3.2 Heat Only ON-OFF Control	12
Figure 3.3 Output 2 Deviation High Alarm	13
Figure 3.4 Output 2 Process Low Alarm	13
Figure 3.5 RAMP Function	14
Figure 3.6 Dwell Timer Function	14
Figure 3.7 PV Shift Application	15
Figure 3.8 Filter Characteristics	15
Figure 3.9 Effects of PID Adjustment	16
Figure 4.1 Heat Control Example	18
Figure 4.2 Cooling Control Example	18
Figure 4.3 Heat-Cool Control Example	19
Table 1.1 Display Form of Characters	3
Table 3.1 Heat-Cool Control Setup Value	11
Table 3.2 PID Adjustment Guide	16
Table A.1 Error Codes and Corrective Actions	27
Appendix	
A-1 Error Codes	27
A-2 Returns, Technical Support	28

Chapter 1 Overview

1-1 General

Tempco's TEC-220 and TEC-920 Fuzzy Logic plus PID microprocessor-based controllers incorporate a bright easy to read 4-digit LED display indicating process value or set point. Fuzzy Logic technology enables a process to reach a predetermined set point in the shortest time with a minimum of overshoot during power-up or external load disturbances.

The TEC-220 is a 1/32 DIN size panel mount controller. The TEC-920 is a 1/16 DIN size panel mount controller. These units are powered by 11–26 or 90–250 VDC/VAC 50/60 Hz supply, incorporating a 2 Amp control relay output as a standard. The second output can be used as a cooling control, an alarm or a dwell timer. Either output can use a triac, 5V logic output, linear current or linear voltage to drive an external device. There are six types of alarms or a dwell timer that can be configured for the second output. The units are fully programmable for PT100 RTD and thermocouple types J, K, T, E, B, R, S, N, and L with no need to modify the unit. The input signal is digitized by using an 18-bit A to D converter. Its fast sampling rate allows the unit to control fast processes.

Digital communications RS-485 is available for the TEC-220 or TEC-920. RS-232 is available for the TEC-220 only. These options allow the units to be integrated with supervisory control systems and software.

A programming port is available for automatic configuration, without the need to access the keys on the front panel.

By using proprietary Fuzzy modified PID technology, the control loop will minimize overshoot and undershoot in a short time. The following diagram is a comparison of results with and without Fuzzy technology.

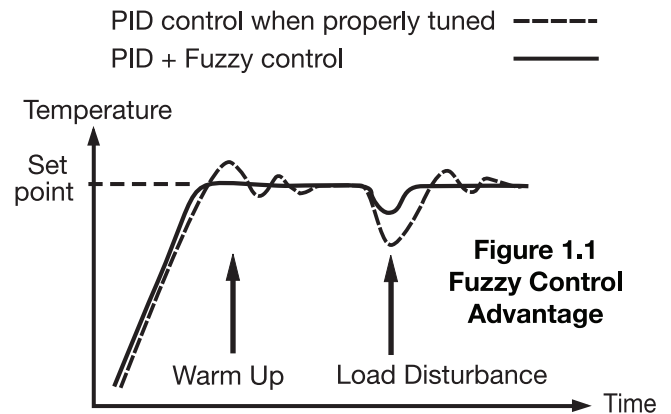

Figure 1-1 Fuzzy Control Advantage

High accuracy

This series is manufactured with custom designed ASIC (Application Specific Integrated Circuit) technology which contains an 18-bit A to D converter for high resolution measurement (true 0.1°F resolution for thermocouple and RTD) and a 15-bit D to A converter for linear current or voltage control output. The ASIC technology provides improved operating performance, low cost, enhanced reliability, and higher density.

Fast sampling rate

The sampling rate of the input A to D converter is 5 times/second. The fast sampling rate allows this series to control fast processes.

Fuzzy control

The function of Fuzzy control is to adjust PID parameters from time to time in order to make manipulation of the output value more flexible and adaptive to various processes. The result is to enable a process to reach a predetermined set point in the shortest time with the minimum of overshoot and undershoot during power-up or external load disturbance.

Digital communication

The units are equipped with an optional RS-485 or RS-232 interface cards to provide digital communication. By using the twisted pair wires up to 247 units can be connected together via RS-485 interface to a host computer.

Programming port

A programming port can be used to connect the unit to a PC for quick configuration.

Auto-tune

The auto-tune function allows the user to simplify initial setup for a new system. An advanced algorithm is used to obtain an optimal set of control parameters for the process, and it can be applied either as the process is warming up (cold start) or when the process is in a steady state (warm start).

Lockout protection

Depending on security requirements, one of four lockout levels can be selected to prevent the unit from being changed without permission.

Bumpless transfer

Bumpless transfer allows the controller to continue to control if the sensor breaks by using its previous value. Hence, the process can be controlled temporarily as if the sensor reading is normal and constant.

Soft-start ramp

The ramping function is performed during power up as well as any time the set point is changed. It can be ramping up or ramping down. The process value will reach the set point at a predetermined constant rate.

Digital filter

A first order low pass filter with a programmable time constant is used to improve the stability of the process value. This is particularly useful in certain applications where the process value is too unstable to be read.

1-2 Hardware Code

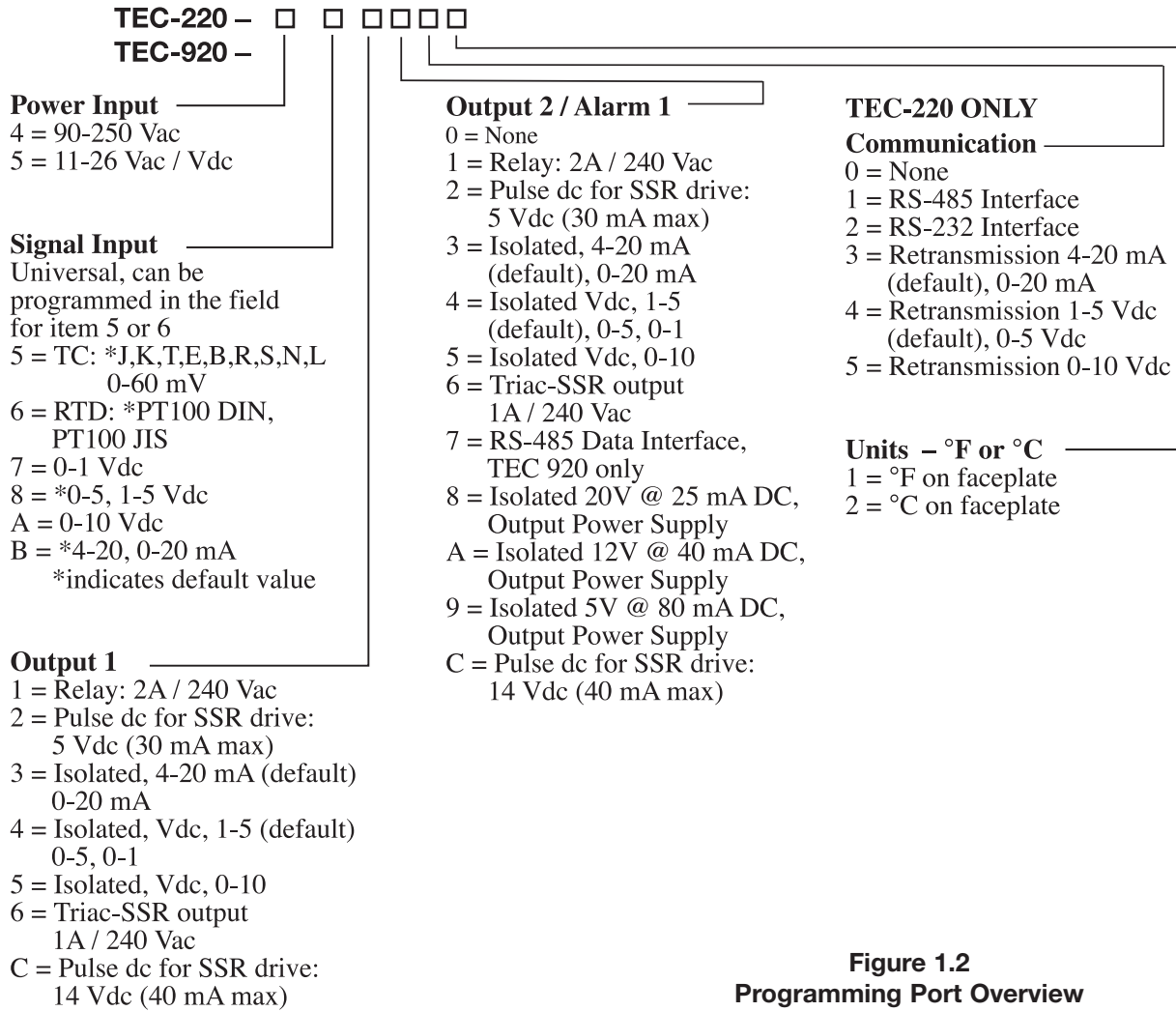

1-3 Programming Port

A special connector can be used to connect the programming port to a PC for automatic configuration.

The programming port is used for off-line automatic setup and testing procedures only. Don't attempt to make any connection to these pins when the unit is under power.

**Figure 1.2
 Programming Port Overview**

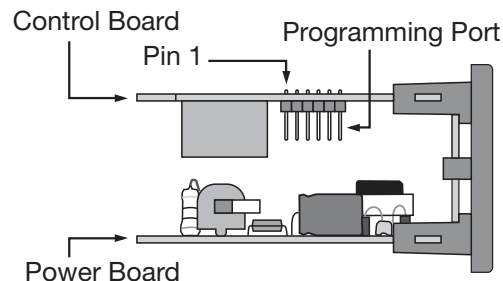
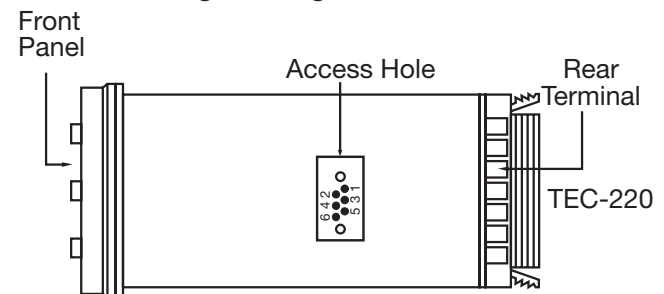

**Open Housing
 Top view of TEC-920**

1-4 Keys and Displays

KEYPAD OPERATION

SCROLL KEY:

This key is used to select a parameter to be viewed or adjusted.

UP KEY:

This key is used to increase the value of the selected parameter.

DOWN KEY:

This key is used to decrease the value of the selected parameter.





RESET KEY: for TEC-920, for TEC-220

This key is used to:

1. Revert the display to show the process value.
2. Reset the latching alarm, once the alarm condition is removed.
3. Stop the manual control mode, auto-tuning mode, and calibration mode.
4. Clear the message of communication error and auto-tuning error.
5. Restart the dwell timer when the dwell timer has timed out.
6. Enter the manual control menu when in failure mode.

ENTER KEY: Press for 5 seconds or longer.

Press  for 5 seconds to:

1. Enter setup menu. The display shows .
2. Enter manual control mode — when manual control mode  or  is selected.
3. Enter auto-tuning mode — when auto-tuning mode  (for 220) or AT (for 920) is selected.
4. Perform calibration to a selected parameter during the calibration procedure.

Press  for 6.2 seconds to select calibration mode.

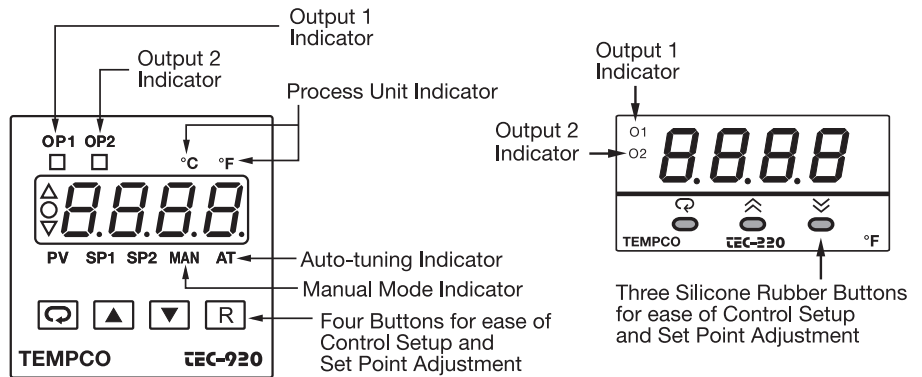
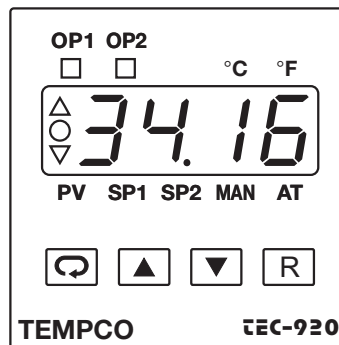

Figure 1.3
Front Panel Description

Table 1.1 Display Form of Characters

A	<i>A</i>	E	<i>E</i>	I	<i>I</i>	N	<i>n</i>	S	<i>S</i>	X	
B	<i>b</i>	F	<i>F</i>	J	<i>J</i>	O	<i>o</i>	T	<i>t</i>	Y	<i>y</i>
C	<i>C</i>	G	<i>G</i>	K	<i>K</i>	P	<i>P</i>	U	<i>u</i>	Z	
c	<i>c</i>	H	<i>H</i>	L	<i>L</i>	Q		V	<i>v</i>	? <i>?</i>	<i>?</i>
D	<i>d</i>	h	<i>h</i>	M	<i>m</i>	R	<i>r</i>	W		=	<i>=</i>

▼: Abstract Characters



Displays program code of the instrument for 2.5 seconds.

The diagram at left shows program no. 34, version 16 for the TEC-920.

The program no. is 33 for the TEC-220.

Figure 1.4
Display in Initial Stage

1-5 Menu Overview

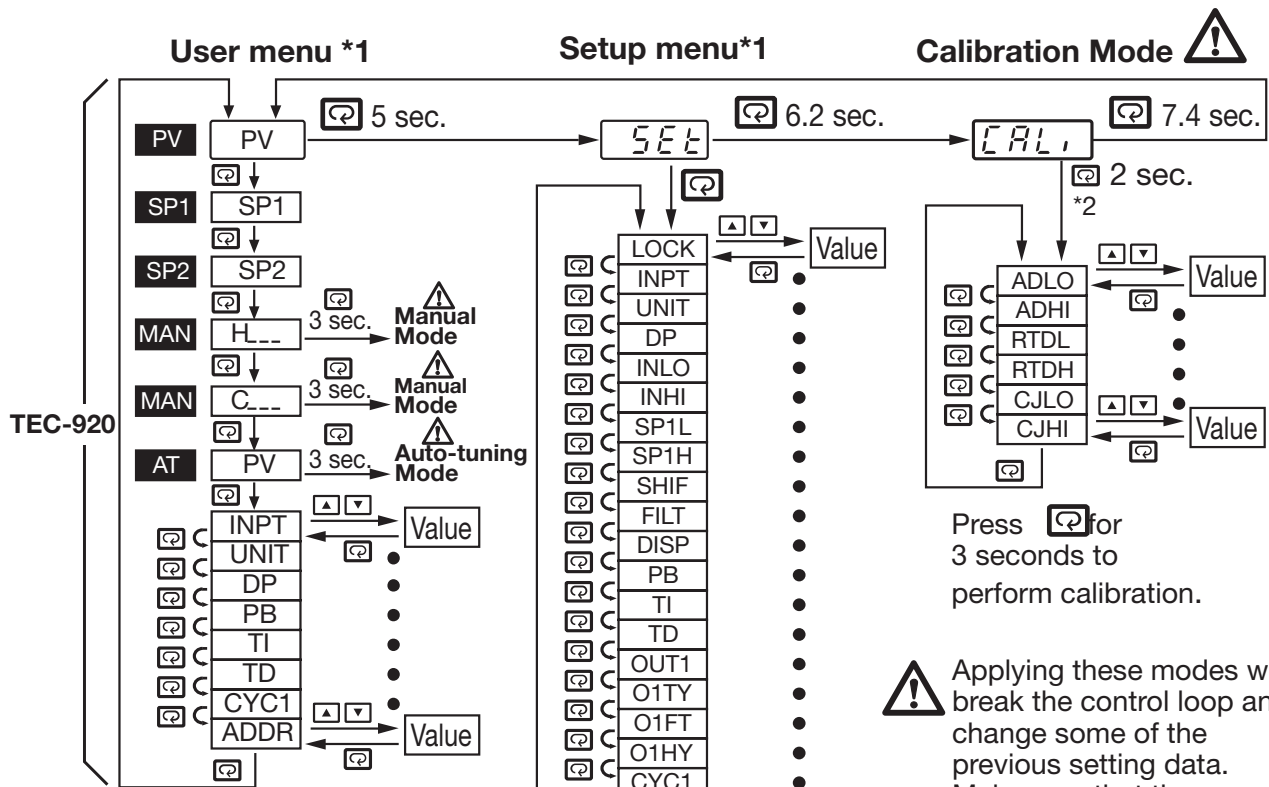

Press [Enter] for 3 seconds to perform calibration.

! Applying these modes will break the control loop and change some of the previous setting data. Make sure that the system is able to apply these modes.

*1: The flow chart shows a complete listing of all parameters. In actual application, the number of available parameters depends on setup conditions, and should be less than that shown in the flow chart.

*2: Release [Enter], press [Enter] again for 2 seconds or longer (but not longer than 3 seconds), then release to enter the calibration menu.

*3: [Up] [Down] Pressed together at any time exits settings and returns display to process and setpoint values.

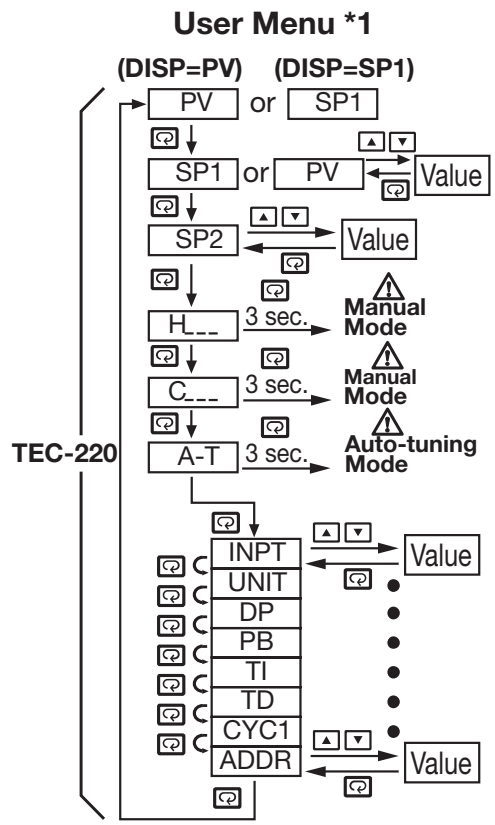

1-6 Parameter Descriptions

Parameter Notation	Parameter Description (Refer to Page:)	Range	Default Value
SP1 SP1	Set point for output 1	Low: SP1L High: SP1H	77.0°F (25.0°C)
SP2 SP2	Set point for output 2 when output 2 performs alarm function or dwell timer	Low: -19999 High: 45536	18.0°F (10.0°C)
LoLl LOCK	Select parameters to be locked out (Page 11)	0) nonE : No parameters are locked 1) SEt : Setup data is locked 2) uSEr : Setup data and User data except Set point are locked 3) ALL : All data are locked	0
inPt INPT	Input sensor selection (Page 11 & 20)	0) J-tC : J type thermocouple 1) K-tC : K type thermocouple 2) T-tC : T type thermocouple 3) E-tC : E type thermocouple 4) B-tC : B type thermocouple 5) R-tC : R type thermocouple 6) S-tC : S type thermocouple 7) N-tC : N type thermocouple 8) L-tC : L type thermocouple 9) Pt100 : PT 100 ohms DIN curve 10) Pt100 : PT 100 ohms JIS curve 11) 4-20 : 4-20 mA linear current input 12) 0-20 : 0-20 mA linear current input 13) 0-60 : 0-60 mV linear millivolt input 14) 0-1V : 0-1V linear voltage input 15) 0-5V : 0-5V linear voltage input 16) 1-5V : 1-5V linear voltage input 17) 0-10 : 0-10V linear voltage input	1 (0)
unit UNIT	Input unit selection	0) C : Degree C unit 1) F : Degree F unit 2) P : Process unit	0 (1)
dP DP	Decimal point selection	0) noDP : No decimal point 1) 1-dP : 1 decimal digit 2) 2-dP : 2 decimal digits 3) 3-dP : 3 decimal digits	0
inLo INLO	Input low scale value (Page 11)	Low: -19999 High: 45486	0°F (-17.8°C)
inHi INHI	Input high scale value (Page 11)	Low: INLO+50 High: 45536	200.0°F (93.3°C)
SP1L SP1L	Low limit of set point (Page 11)	Low: -19999 High: 45536	0°F (-17.8°C)
SP1H SP1H	High limit of set point value (Page 11)	Low: SP1L High: 45536	1000°F (538°C)
SHiF SHIF	PV shift (offset) value (Page 15)	Low: -360.0°F (-200.0°C) High: 360.0°F (200.0°C)	0.0
Filt FILT	Filter damping time constant of PV (Page 15)	0) 0 : 0 second time constant 1) 0.2 : 0.2 second time constant 2) 0.5 : 0.5 second time constant 3) 1 : 1 second time constant 4) 2 : 2 seconds time constant 5) 5 : 5 seconds time constant 6) 10 : 10 seconds time constant 7) 20 : 20 seconds time constant 8) 30 : 30 seconds time constant 9) 60 : 60 seconds time constant	2
disP DISP	Normal display selection	0) PV : Display process value 1) SP1 : Display set point 1 value	0

Parameter Notation	Parameter Description (Refer to Page:)	Range	Default Value
Pb PB	Proportional band value (Page 16)	Low: 0 High: 900.0°F (500.0°C)	18.0°F (10.0°C)
ti TI	Integral time value	Low: 0 High: 1000 sec	100
td TD	Derivative time value	Low: 0 High: 360.0 sec	25.0
out1 OUT1	Output 1 function	0) rEvR : Reverse (heating) control action 1) dirct : Direct (cooling) control action	0
o1ty O1TY	Output 1 signal type (Page 20)	0) rELy : Relay output 1) SSRd : Solid state relay drive output 2) SSR : Solid state relay output 3) 4-20 : 4-20 mA DC 4) 0-20 : 0 - 20 mA DC 5) 0-1V : 0 - 1V DC 6) 0-5V : 0 - 5V DC 7) 1-5V : 1 - 5V DC 8) 0-10 : 0 - 10V DC	0
o1ft O1FT	Output 1 failure transfer mode (Page 15)	Select BPLS (bumpless transfer) or 0.0 - 100.0% to continue output 1 control function as the unit fails, or select OFF (0) or ON (1) for ON-OFF control.	0
o1hy O1HY	Output 1 ON-OFF hysteresis (Page 12)	Low: 0.1 High: 90°F (50.0°C)	0.2°F (0.1°C)
cyCl CYCL	Output 1 cycle time	Low: 0.1 High: 90.0 sec.	18.0
oFSt OFST	Offset value for P control	Low: 0 High: 100.0%	25.0
rRnP RAMP	Ramp function selection (Page 14)	0) nonE : No ramp function 1) ni nR : Use unit/minute as Ramp Rate 2) HrR : Use unit/hour as Ramp Rate	0
rr RR	Ramp rate (Page 14)	Low: 0 High: 900.0°F (500.0°C)	0.0
out2 OUT2	Output 2 function (Page 13 & 20)	0) nonE : Output 2 No Function 1) ti nR : Dwell timer action 2) dEHi : Deviation High 3) dELo : Deviation Low 4) dbHi : Deviation band out of band alarm 5) dbLo : Deviation band in band alarm 6) P4Hi : Process High 7) P4Lo : Process Low 8) Cool : Cooling PID Function	2
o2ty O2TY	Output 2 signal type (Page 20)	0) rELy : Relay output 1) SSRd : Solid state relay drive output 2) SSR : Solid state relay output 3) 4-20 : 4-20 mA DC 4) 0-20 : 0 - 20 mA DC 5) 0-1V : 0 - 1V DC 6) 0-5V : 0 - 5V DC 7) 1-5V : 1 - 5V DC 8) 0-10 : 0 - 10V DC	0
o2ft O2FT	Output 2 failure transfer mode (Page 15)	Select BPLS (bumpless transfer) or 0.0 - 100.0% to continue output 2 control function as the unit fails, or select OFF (0) or ON (1) for alarm function.	0

1-6 Parameter Descriptions, continued...

Parameter Notation	Parameter Description (Refer to Page:)	Range	Default Value
<i>o2HY</i> O2HY	Output 2 hysteresis value when output 2 performs alarm function	Low: 0.1 High: 90.0°F (50.0°C)	0.2°F (0.1°C)
<i>CYC2</i> CYC2	Output 2 cycle time	Low: 0.1 High: 90.0 sec.	18.0
<i>CPb</i> CPB	Cooling proportional band value (Page 12)	Low: 50 High: 300%	100
<i>db</i> DB	Heating-cooling dead band (negative value=overlap) (Page 12)		0
<i>ALMD</i> ALMD	Alarm operation mode (Page 13)	0) <i>norm</i> : Normal alarm action 1) <i>Ltch</i> : Latching alarm action 2) <i>Hold</i> : Hold alarm action 3) <i>LtHo</i> : Latching & Hold action	0
<i>COMM</i> COMM	Communication function (Page 17 & 24)	0) <i>none</i> : No communication 1) <i>rtu</i> : Modbus RTU mode protocol 2) <i>4-20</i> : 4 - 20 mA retransmission output 3) <i>0-20</i> : 0 - 20 mA retransmission output 4) <i>0-5v</i> : 0 - 5 V retransmission output 5) <i>1-5v</i> : 1 - 5 V retransmission output 6) <i>0-10</i> : 0 - 10 V retransmission output	1
<i>ADDR</i> ADDR	Address assignment for digital communication	Low: 1 High: 255	—
<i>BAUD</i> BAUD	Baud rate of digital communication (Page 23)	0) <i>2.4</i> : 2.4 Kbits/s baud rate 1) <i>4.8</i> : 4.8 Kbits/s baud rate 2) <i>9.6</i> : 9.6 Kbits/s baud rate 3) <i>14.4</i> : 14.4 Kbits/s baud rate 4) <i>19.2</i> : 19.2 Kbits/s baud rate 5) <i>28.8</i> : 28.8 Kbits/s baud rate 6) <i>38.4</i> : 38.4 Kbits/s baud rate	2
<i>DATA</i> DATA	Data bit count of digital communication	0) <i>7bit</i> : 7 data bits 1) <i>8bit</i> : 8 data bits	1
<i>PARI</i> PARI	Parity bit of digital communication	0) <i>Even</i> : Even parity 1) <i>odd</i> : Odd parity 2) <i>none</i> : No parity bit	0
<i>STOP</i> STOP	Stop bit count of digital communication	0) <i>1bit</i> : One stop bit 1) <i>2bit</i> : Two stop bits	0
<i>RELO</i> RELO	Retransmission low scale value (Page 17)	Low: -19999 High: 45536	32.0°F (0.0°C)
<i>REHI</i> REHI	Retransmission high scale value (Page 17)	Low: INLO+50 High: 45536	212.0°F (100.0°C)

Parameter Notation	Parameter Description (Refer to Page:)	Range	Default Value
<i>SEL1</i> SEL1	Select 1st parameter for user menu (Page 4)	0) <i>none</i> : No parameter selected 1) <i>Lock</i> : LOCK is put ahead 2) <i>INPT</i> : INPT is put ahead 3) <i>UNIT</i> : UNIT is put ahead 4) <i>DP</i> : DP is put ahead 5) <i>SHIF</i> : SHIF is put ahead 6) <i>PB</i> : PB is put ahead 7) <i>TI</i> : TI is put ahead 8) <i>TD</i> : TD is put ahead 9) <i>O1HY</i> : O1HY is put ahead 10) <i>CYC1</i> : CYC1 is put ahead 11) <i>OFST</i> : OFST is put ahead 12) <i>RR</i> : RR is put ahead 13) <i>O2HY</i> : O2HY is put ahead 14) <i>CYC2</i> : CYC2 is put ahead 15) <i>CPb</i> : CPB is put ahead 16) <i>db</i> : DB is put ahead 17) <i>ADDR</i> : ADDR is put ahead 18) <i>ALHY</i> : ALHY is put ahead	2
<i>SEL2</i> SEL2	Select 2nd parameter for user menu	Same as SEL1	3
<i>SEL3</i> SEL3	Select 3rd parameter for user menu	Same as SEL1	4
<i>SEL4</i> SEL4	Select 4th parameter for user menu	Same as SEL1	6
<i>SEL5</i> SEL5	Select 5th parameter for user menu	Same as SEL1	7
<i>SEL6</i> SEL6	Select 6th parameter for user menu	Same as SEL1	8
<i>SEL7</i> SEL7	Select 7th parameter for user menu	Same as SEL1	10
<i>SEL8</i> SEL8	Select 8th parameter for user menu	Same as SEL1	17

Chapter 2 Installation

⚠ Dangerous voltages capable of causing death are sometimes present in this instrument. Before installation or beginning any troubleshooting procedures, the power to all equipment must be switched off and isolated. Units suspected of being faulty must be disconnected and removed to a properly equipped workshop for testing and repair. Component replacement and internal adjustments must be made by a qualified maintenance person only.

⚠ This instrument is protected by double insulation. To minimize the possibility of fire or shock hazards do not expose this instrument to rain or excessive moisture.

⚠ Do not use this instrument in areas under hazardous conditions such as excessive shock, vibration, dirt, moisture, corrosive gases or oil. The ambient temperature of the area should not exceed the maximum rating specified in chapter 6.

⚠ Remove stains from this instrument using a soft, dry cloth. To avoid deformation or discoloration do not use harsh chemicals, volatile solvent such as thinner or strong detergents to clean this instrument.

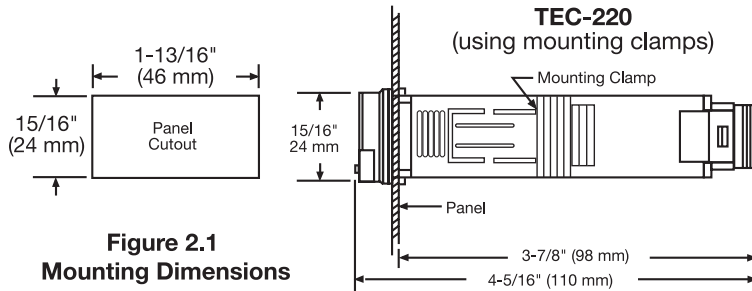

Figure 2.1
Mounting Dimensions

2-3 Wiring Precautions

- Before wiring, verify the correct model number and options on the label. Switch off the power while checking.
- Care must be taken to ensure that the maximum voltage rating specified on the label is not exceeded.
- It is recommended that the power for these units be protected by fuses or circuit breakers rated at the minimum value possible.
- All units should be installed in a suitable enclosure to prevent live parts from being accessible to human hands and metal tools. Metal enclosures and/or subpanels should be grounded in accordance with national and local codes.
- All wiring must conform to appropriate standards of good practice and local codes and regulations. Wiring must be suitable for the voltage, current, and temperature rating of the system.
- Beware not to over-tighten the terminal screws. The torque should not exceed 1 N-m (8.9 lb-in or 10 KgF-cm).
- Unused control terminals should not be used as jumper points as they may be internally connected, causing damage to the unit.
- Verify that the ratings of the output devices and the inputs as specified are not exceeded.
- Except for thermocouple wiring, all wiring should use stranded copper conductor with a maximum gage of 14 AWG.
- Electrical power in industrial environments contains a certain amount of noise in the form of transient voltage and spikes. This electrical noise can adversely affect the operation of microprocessor-based controls. For this reason the use of shielded thermocouple extension wire which connects the sensor to the controller is strongly recommended. This wire is a twisted-pair construction with foil wrap and drain wire. The drain wire is to be attached to ground in the control panel only.

2-1 Unpacking

Upon receipt of the shipment, remove the unit from the carton and inspect the unit for shipping damage.

2-2 Mounting

Make the panel cutout according to the dimensions shown in Figure 2.1.

Take the mounting clamp away and insert the controller into the panel cutout. Reinstall the mounting clamp.

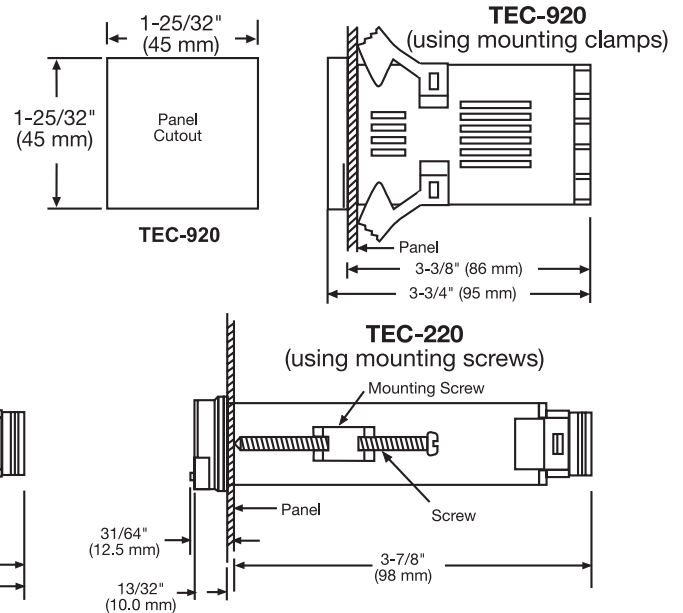

Note: All model TEC-220 controls are supplied with both mounting clamps and mounting screws. The mounting screws have to be used in NEMA 4X applications as they allow the control to be held tighter into the panel. The mounting clamp teeth are released by depressing the ends of the clamp together.

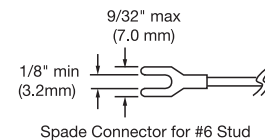

Figure 2.2
Lead Termination for TEC-920

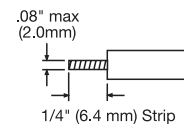

Figure 2.3
Lead Termination for TEC-220

Transit Damage

If there is any damage due to transit, report it and file a claim with the carrier. Write down the model number, serial number, and date code for future reference when corresponding with our service center. The serial number (S/N) is labeled on the box and the housing of the control.

Wiring, continued...

Wiring, continued...

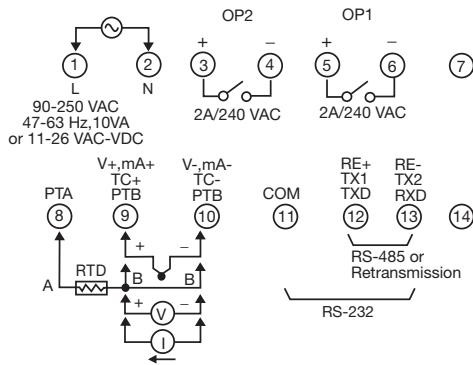

Figure 2.4
Rear Terminal Connections for TEC-220

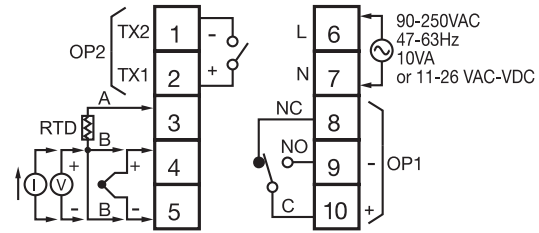

Figure 2.5
Rear Terminal Connections for TEC-920

2-4 Power Wiring

The controller is designed to operate at 11–26VAC/VDC or 90–250VAC. Check that the input voltage corresponds to the power rating indicated on the product label before connecting power to the controller.

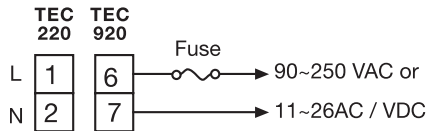

Figure 2.6
Power Supply Connections



This equipment is designed for installation in an enclosure which provides adequate protection against electric shock. Metal enclosures must be connected to earth ground.

Local requirements regarding electrical installation should be rigidly observed. Consideration should be given to prevent unauthorized personnel from accessing the power terminals.

2-5 Sensor Installation Guidelines

Proper sensor installation can eliminate many problems in a control system. The probe should be placed so that it can detect any temperature change with minimal thermal lag. In a process that requires fairly constant heat output, the probe should be placed close to the heater. In a process where the heat demand is variable, the probe should be close to the work area. Some experimentation with probe location is often required to find the optimum position.

In a liquid process, the addition of a stirrer will help to eliminate thermal lag. Since the thermocouple is basically a point measuring device, placing more than one thermocouple in parallel can provide an average temperature readout and produce better results in most air heated processes. Proper sensor type is also a very important factor in obtaining precise measurements. The sensor must have the correct temperature range to meet the process requirements. In special processes, the sensor might have requirements such as leak-proof, anti-vibration, antiseptic, etc.

Standard sensor limits of error are $\pm 4^{\circ}\text{F}$ ($\pm 2^{\circ}\text{C}$) or 0.75% of the sensed temperature (half that for special) plus drift caused by improper protection or an over-temperature occurrence. This error is far greater than controller error and cannot be corrected on the sensor except by proper selection and replacement.

2-6 Sensor Input Wiring

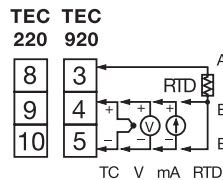

Figure 2.7

2-7 Control Output Wiring

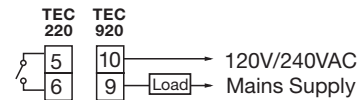

Figure 2.8
Output 1 Relay or
Triac (SSR) to Drive Load

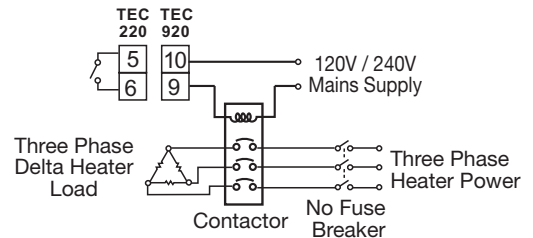

Figure 2.9
Output 1 Relay or Triac (SSR)
to Drive Contactor

Control Output Wiring, continued...

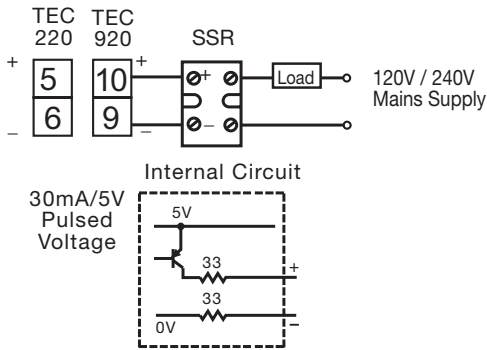

Figure 2.10 Output 1 Pulsed Voltage to Drive SSR

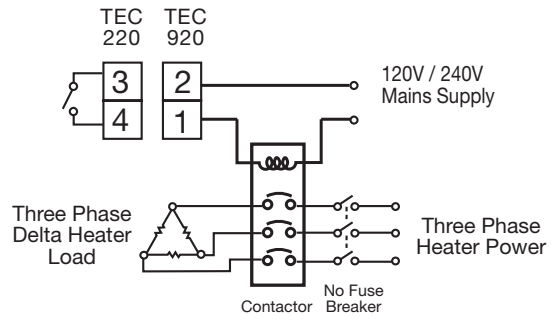

Figure 2.14 Output 2 Relay or Triac (SSR) to Drive Contactor



Figure 2.11 Output 1 Linear Current

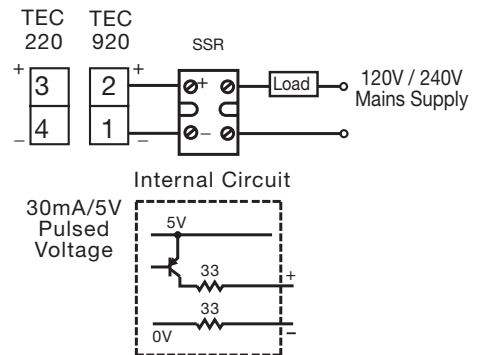

Figure 2.15 Output 2 Pulsed Voltage to Drive SSR

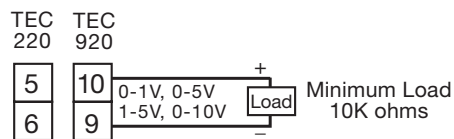

Figure 2.12 Output 1 Linear Voltage

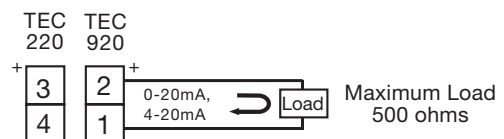

Figure 2.16 Output 2 Linear Current

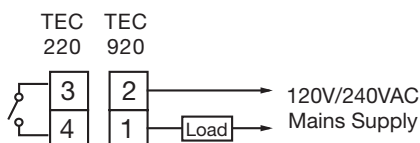

Figure 2.13 Output 2 Relay or Triac (SSR) to Drive Load

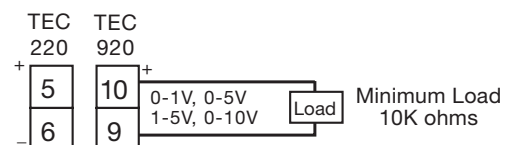

Figure 2.17 Output 2 Linear Voltage

2-8 Alarm Wiring

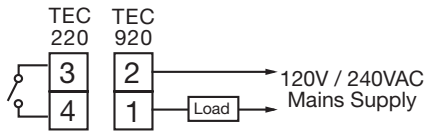

Figure 2.18 Alarm Output to Drive Load

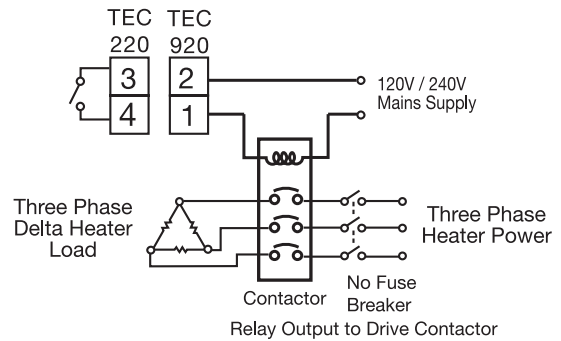

Figure 2.19 Alarm Output to Drive Contactor

2-9 Data Communication

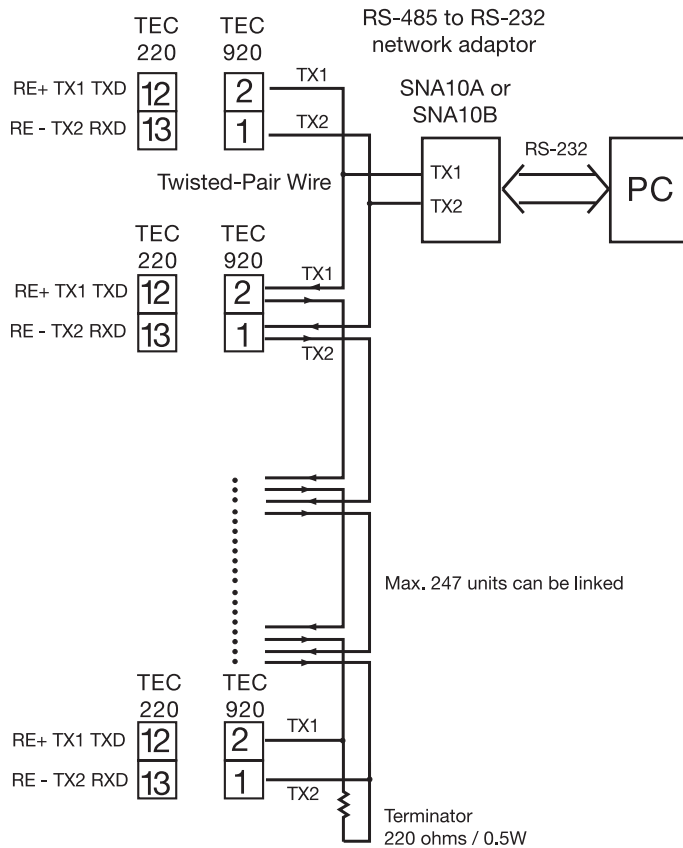

Figure 2.20 RS-485 Wiring

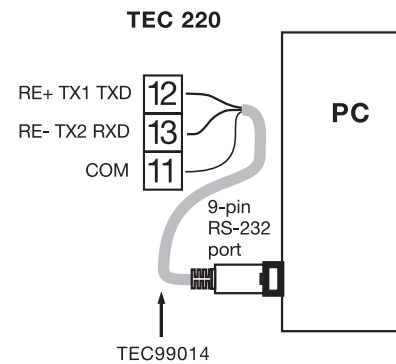

Figure 2.21 RS-232 Wiring

If you use a conventional 9-pin RS-232 cable instead of TEC99014, the cable must be modified according to the following circuit diagram.

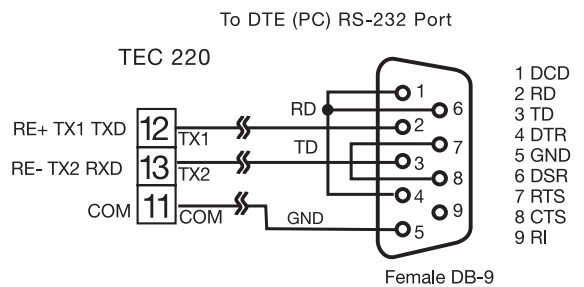





Figure 2.22 Configuration of RS-232 Cable

Chapter 3 Programming

Press  for 5 seconds and release to enter the setup menu. Press and release  to select the desired parameter. The display indicates the parameter symbol. Press  or  to view or adjust the value of the selected parameter.

3-1 Lockout

There are four security levels that can be selected using the LOCK parameter.

If **NONE** is selected for LOCK, then no parameter is locked.

If **SET** is selected for LOCK, then all setup data are locked.

If **USER** is selected for LOCK, then all setup data as well as user data (refer to section 1-5) except the set point are locked to prevent them from being changed.

If **ALL** is selected for LOCK, then all parameters are locked to prevent them from being changed.

How to use Conversion Curve for Process Value:

If 4-20mA is selected for INPT, SL specifies the input signal low (i.e., 4mA), SH specifies the input signal high (i.e., 20mA), S specifies the current input signal value, and the conversion curve of the process value is shown as follows:

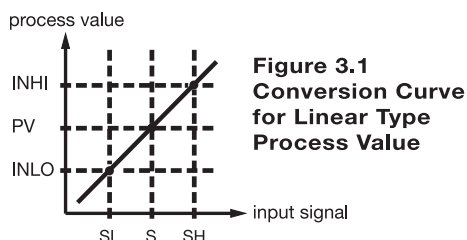

$$\text{Formula: } PV = INLO + (INHI - INLO) \frac{S - SL}{SH - SL}$$

Example: A 4-20 mA current loop pressure transducer with range 0-15 kg/cm² is connected to input, then perform the following setup:

INPT = 4-20 INLO = 0.00

INHI = 15.00 DP = 2-DP

Of course, you may select other value for DP to alter the resolution.

SL = Setpoint Low Limit SH = Setpoint High Limit

3-3 Control Outputs

There are four kinds of control modes that can be configured as shown in table 3.1.

Table 3.1 Heat-Cool Control Setup Value

Control Modes	OUT1	OUT2	O1HY	O2HY	CPB	DB
Heat only	REVR	×	☆	×	×	×
Cool only	DIRT	×	☆	×	×	×
Heat: PID Cool: ON-OFF	REVR	DE.HI	×	○	×	×
Heat: PID Cool: PID	REVR	COOL	×	×	○	○

× : Does not apply

○ : Adjust to meet process requirements

☆ : Required if ON-OFF control is configured

OUT1:
Output 1 Type

OUT2:
Output 2 Type

O1HY:
Output 1 Hysteresis

O2HY:
Output 2 Hysteresis

CPB:
Cooling Proportional Band

DB:
Heating Cooling Dead Band

3-2 Signal Input

INPT: Selects the sensor type or signal type for signal input.

Range: (thermocouple) Type J, K, T, E, B, R, S, N, L
(RTD) PT.DN, PT.JS
(Linear) 4-20 mA, 0-20 mA, 0-60 mA, 0-1V,
0-5V, 1-5V, 0-10V

UNIT: Selects the process unit

Range: °C, °F, PU (process unit). If the unit is set for neither °C nor °F, then it defaults to PU.

DP: Selects the resolution of process value.

Range: (For T/C and RTD) NO.DP, 1-DP
(For linear) NO.DP, 1-DP, 2-DP, 3-DP

INLO: Selects the low scale value for the linear type input.

INHI: Selects the high scale value for the linear type input.

Control Outputs, continued...

Heat only ON-OFF control: Select REVR for OUT1. Set PB (Proportional Band) to 0. O1HY is used to adjust dead band for ON-OFF control. The output 1 hysteresis (O1HY) is enabled when PB=0. The heat only on-off control function is shown in the following diagram:

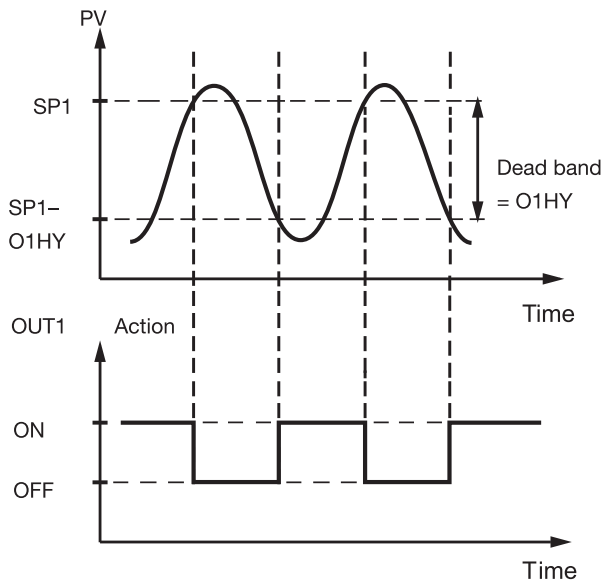

Figure 3.2 Heat Only ON-OFF Control

The ON-OFF control may introduce excessive process oscillation even if hysteresis is minimized. If ON-OFF control is set (i.e., PB=0), TI, TD, CYC1, OFST, CYC2, CPB, and DB will be hidden and have no function in the system. The auto-tuning and bumpless transfer function will be disabled as well.

Heat only P (or PD) control: Select H.TPC or H.L I N for OUT1 and set TI1 and TI2 to 0, OFST is used to adjust the control offset (manual reset). O1HY is hidden if PB is not equal to 0.

OFST function: OFST is measured in % with a range of 0–100.0%.

In a steady state (i.e. process has stabilized at a temperature), if the process value is lower than the set point by a constant value (we'll say 5°C) while the PB setting is set for 20°C, we can say the temperature is lower than the setpoint by 25% of the PB setting. This can be corrected by increasing the OFST setting to 25%. After adjusting the OFST value, the process value will eventually coincide with set point.

Note that using the P control (TI set to 0), disables auto-tuning.

Refer to Section 3-12 “manual tuning” for the adjustment of P and PD. Manual reset (adjust OFST) is sometimes not practical since the load may change from time to time and OFST may need to be adjusted repeatedly. PID control can avoid this situation.

Heat only PID control: If REVR is selected for OUT1, PB and TI should not be zero. Perform auto-tuning for the new process, or set PB, TI, and TD with historical values. See section 3-11 for auto-tuning operation. If the control result is still unsatisfactory, then use manual tuning to improve control. See section 3-12 for manual tuning. The unit contains an advanced PID and Fuzzy algorithm to create a small overshoot and very quick response to the process if it is properly tuned.

Cool only control: ON-OFF control, P (PD) control, and PID control can be used for cool control. Set OUT1 to DIRT (direct action). The other functions for cool only ON-OFF control, cool only P (PD) control, and cool only PID control are the same as for heat only control except that the output variable (and action) for cool control is inverse to heat control.

NOTE: ON-OFF control may result in excessive overshoot and undershoot problems in the process. P (or PD) control will result in a deviation of process value from the set point. It is recommended to use PID control for heat-cool control to produce a stable and zero offset process value.

Other setup required: O1TY, CYC1, O2TY, CYC2, O1FT and O2FT are set in accordance with the types of OUT1 and OUT2 installed. CYC1 and CYC2 are selected according to the output 1 type (O1TY) and output 2 type (O2TY). Generally, select 0.5~2 seconds for CYC1 if SSRD or SSR is used for O1TY; 10~20 seconds if relay is used for O1TY and CYC1 is ignored if linear output is used. Similar conditions are applied for CYC2 selection.

You can use the auto-tuning program for the new process or directly set the appropriate values for PB, TI, and TD according to historical records for duplicate systems. If the control behavior is still inadequate, then use manual tuning to improve the control. See section 3-12 for manual tuning.

CPB (Cooling Proportional Band) Programming: The cooling proportional band is measured by % of PB with a range of 50-300. Initially set 100% for CPB and examine the cooling effect. If the cooling action should be enhanced, then decrease CPB, if the cooling action is too strong, then increase CPB. The value of CPB is related to PB and its value remains unchanged throughout the auto-tuning procedures.

Adjustment of CPB is related to the cooling medium used. If air is used as the cooling medium, initially set CPB to 100%, then adjust as necessary. If oil is used as the cooling medium, initially set CPB to 125%, then adjust as necessary. If water is used as the cooling medium, initially set CPB to 250%, then adjust as necessary.

DB (Heating-Cooling Dead Band) programming: The adjustment of DB is dependent on the system requirements. If a more positive value of DB (greater dead band) is used, an unwanted cooling action can be avoided but an excessive overshoot over the set point will occur. If a more negative value of DB (greater overlap) is used, an excessive overshoot over the set point can be minimized, but an unwanted cooling action will occur. It is adjustable in the range -36.0% to 36.0% of PB. A negative DB value shows an overlap area over which both outputs are active. A positive DB value shows a dead band area over which neither output is active.

Output 2 ON-OFF control (alarm function): Output 2 can also be configured with an alarm function. There are six kinds of alarm functions that can be selected for output 2. These are: **DE.HI** (deviation high alarm), **DE.LO** (deviation low alarm), **DB.HI** (deviation band out of band alarm), **DB.LO** (deviation band in band alarm), **PV.HI** (process high alarm), and **PV.LO** (process low alarm). Refer to figure 3.3 and figure 3.4 for descriptions of the deviation alarm and the process alarm.

3.3 & 3.4 Alarm Figures

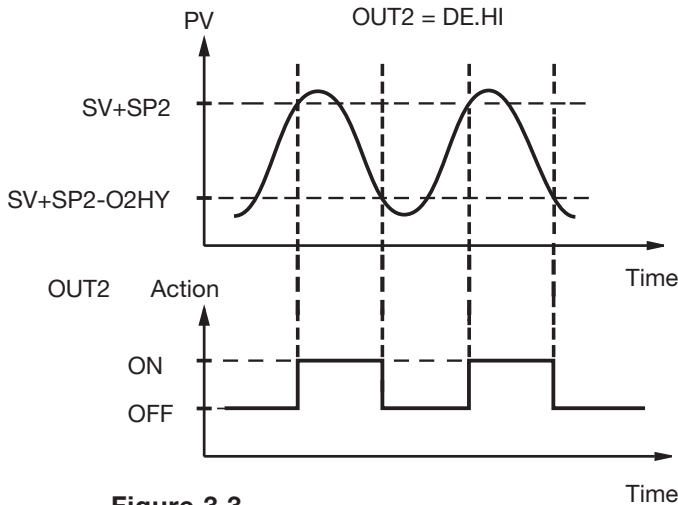

Figure 3.3
Output 2 Deviation High Alarm

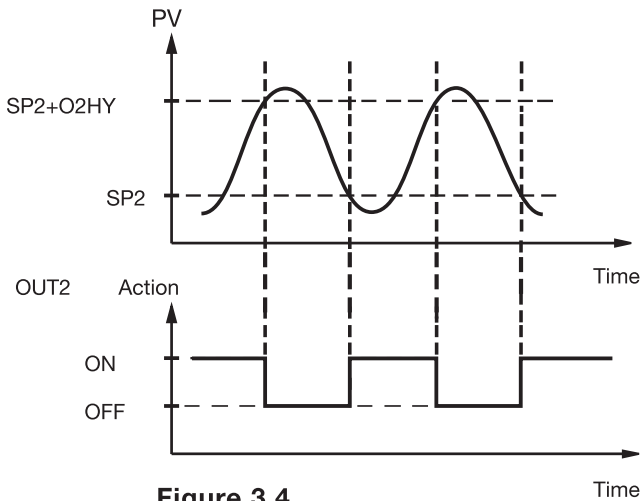

Figure 3.4
Output 2 Process Low Alarm

3-4 Alarm

Output 2 can be set as an alarm output. There are six types of alarm functions and one dwell timer that can be selected, and four kinds of alarm modes (ALMD) are available for each alarm function.

A **process alarm** sets two absolute trigger levels. When the process value is higher than SP2, a process high alarm (PV.HI) occurs. The alarm is off when the process value is lower than SP2-ALHY. When the process value is lower than SP2, a process low alarm (PV.LO) occurs, and the alarm is off when the process value is higher than SP2+ALHY. A process alarm is independent of the set point.

A **deviation alarm** alerts the user when the process value deviates too far from the set point. When the process value is higher than SV+SP2, a deviation high alarm (DE.HI) occurs, and the alarm is off when the process value is lower than SV+SP2-ALHY. When the process value is lower than SV+SP2, a deviation low alarm (DE.LO) occurs, and the alarm is off when the process value is higher than SV+SP2+ALHY. The trigger level of the deviation alarm moves with the set point.

A **deviation band alarm** presets two trigger levels relative to the set point. The two trigger levels are SV+SP2 and SV-SP2 for alarm. When the process value is higher than (SV+SP2) or lower than (SV-SP2), a deviation band high alarm (DB.HI) occurs. When the process value is within the trigger levels, a deviation band low alarm (DB.LO) occurs.

There are four types of alarm modes available for each alarm function. These are: normal alarm, latching alarm, holding alarm and latching/holding alarm. They are described as follows:

Normal alarm: ALMD=NORM

When a normal alarm is selected, the alarm output is de-energized in the non-alarm condition and energized in an alarm condition.

Latching alarm: ALMD=LTCH

If a latching alarm is selected, once the alarm output is energized, it will remain unchanged even if the alarm condition is cleared. The latching alarm is reset when the RESET key is pressed after the alarm condition is removed.

Holding alarm: ALMD=HOLD

A holding alarm prevents an alarm when the control is powering up. The alarm is enabled only when the process reaches the set point value. Afterwards, the alarm performs the same function as a normal alarm.

Latching/holding alarm: ALMD=LT.HO

A latching/holding alarm performs both holding and latching functions. The latching alarm is reset when the RESET key is pressed after the alarm condition is removed.

Alarm failure transfer is activated as the unit enters failure mode. The alarm will go on if ALFT is set for ON and go off if ALFT is set for OFF. The unit will enter failure mode when a sensor break occurs or if the A-D converter of the unit fails.

3-5 Configuring the Display

The TEC-220 can be configured to display the process value by selecting PV for DISP or to display the set point value by selecting SP1 for DISP.

If LOCK is set to NONE, OUT2 is set to DEHI, and DISP is set to PV, set SEL1=SHIF, SEL2=ADDR. SEL3=PB, SEL4~SEL8=NONE, then the display scrolling for the TEC-220 will become:

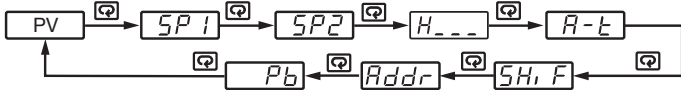

If LOCK is set to NONE, OUT1 is set to REVR, a non-zero value is set for PB and TI, OUT2 is set to COOL, and DISP is set to SP1, set SEL1=INPT, SEL2=PB, SEL3=TI, SEL4~SEL8=NONE, then the display scrolling for the TEC-220 will become:

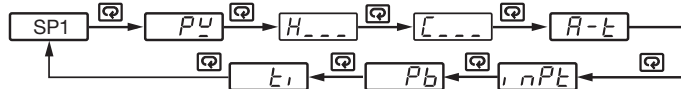

Example for TEC-920:

Set OUT2=PVLO, LOCK=NONE, SEL1=INPT, SEL2=UNIT, SEL3=DP, SEL4~SEL8=NONE, then the display scrolling for the TEC-920 will become:

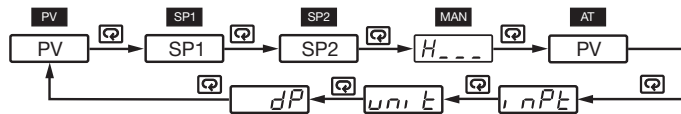

3-6 Ramp

Ramp

The ramping function is performed during power up as well as any time the set point is changed. If MINR or HRR is chosen for RAMP, the unit will perform the ramping function. The ramp rate is programmed by adjusting RR. The ramping function is disabled as soon as failure mode, manual control mode, auto-tuning mode or calibration mode is entered.

Example without dwell timer

Select MINR for RAMP, select °C for UNIT, select 1-DP for DP, set RR=10.0. SV is set to 200°C initially, and changed to 100°C 30 minutes after power-up. The starting temperature is 30°C. After power-up, the process runs like the curve shown in Figure 3.5.

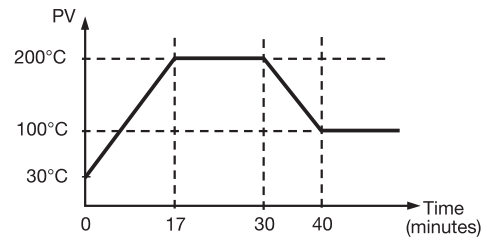

Figure 3.5 RAMP Function

Note: When the ramp function is used, the lower display will show the current ramping value. The ramping value is an artificially determined setpoint created and updated by the control to match the ramp rate set by the user. However, it will revert to show the set point value as soon as the up or down key is touched for adjustment. The ramping value is initiated to process value either on power-up or when RR and/or the set point are changed. Setting RR to zero means no ramp function.

3-7 Dwell Timer

Output 2 can be configured as a dwell timer by selecting TIMR for OUT2. As the dwell timer is configured, the parameter SP2 is used for dwell time adjustment. The dwell time is measured in minutes ranging from 0.1 to 4553.6 minutes. Once the process reaches the set point the dwell timer starts to count down to zero (time out). The timer relay will remain unchanged until time out. The dwell timer operation is shown in the following diagram.

After time out, the dwell timer can be restarted by pressing the RESET key.

The timer stops counting during manual control mode, failure mode, the calibration period and the auto-tuning period.

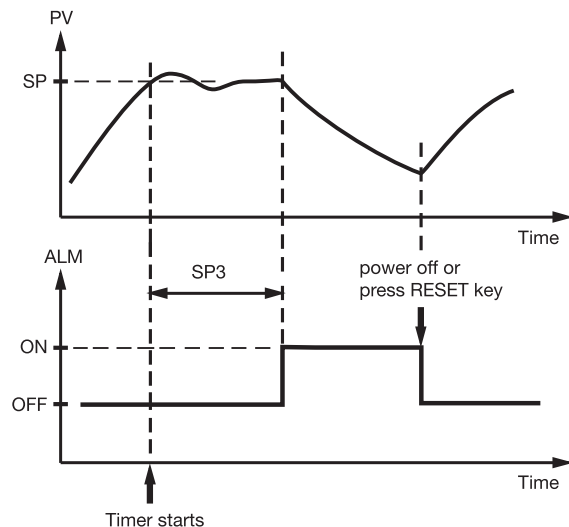

Figure 3.6 Dwell Timer Function

If output 2 is configured as a dwell timer, ALMD will be hidden.

3-8 PV Shift

In certain applications it is desirable to shift the controller display value from its actual value. This can easily be accomplished by using the PV shift function.

The SHIF function will alter PV only.

Here is an Example: A process is equipped with a heater, a sensor, and a subject to be warmed up. Due to the design and position of the components in the system, the sensor could not be placed any closer to the part. Thermal gradient (differing temperatures) is common and necessary to an extent in any thermal system for heat to be transferred from one point to another. If the difference between the sensor and the subject is 35°C, and the desired temperature at the subject to be heated is 200°C, the controlling value or the temperature at the sensor should be 235°C. You should enter -35°C to subtract 35°C from the actual process display. This in turn will cause the controller to energize the load and bring the process display up to the set point value.

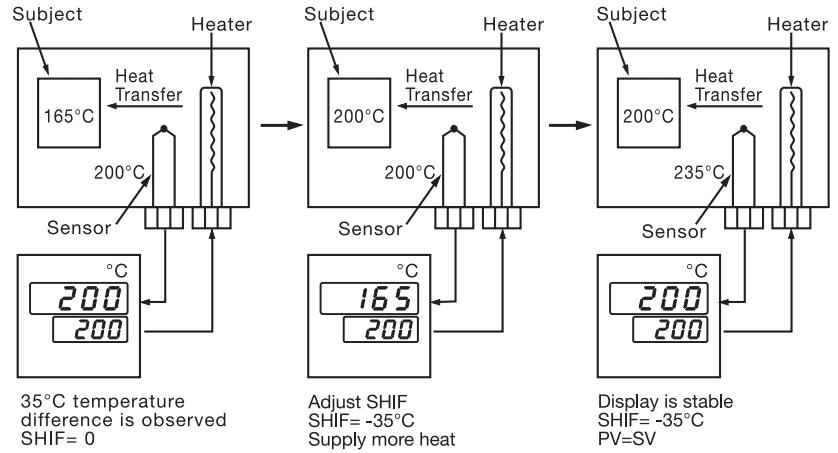

Figure 3.7 PV Shift Application

3-9 Digital Filter

In certain applications, the process value is too unstable to be read due to possible electrical noise. A programmable low-pass filter incorporated in the controller can be used to improve this. It is a first-order filter with the time constant specified by the FILT parameter. The default value of FILT is set at 0.5 seconds before shipping. Adjust FILT to change the time constant from 0 to 60 seconds. 0 seconds means no filter is applied to the input signal. The filter is characterized in Figure 3.8.

Note

The filter is available only for PV, and is performed for the displayed value only. The controller is designed to use unfiltered signal for control even if the filter is applied. A lagged (filtered) signal, if used for control, may produce an unstable process.

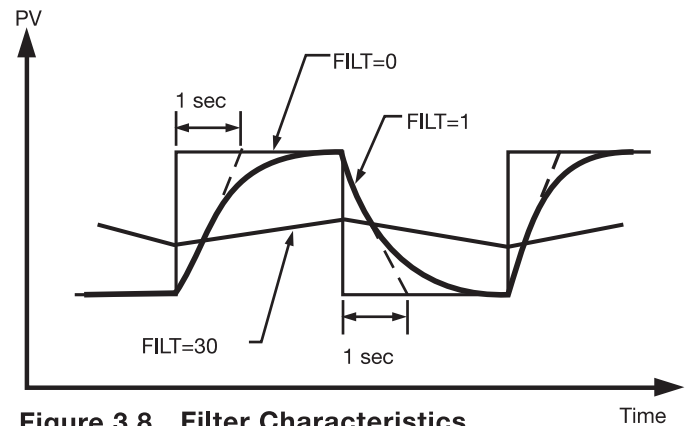

Figure 3.8 Filter Characteristics

3-10 Failure Transfer

The controller will enter failure mode if one of the following conditions occurs:

1. **SBER** occurs due to input sensor break or input current below 1mA if 4-20 mA is selected or input voltage below 0.25V if 1-5V is selected.
2. **ADER** occurs due to the A-D converter of the controller failing.

Output 1 and output 2 will perform the failure transfer function as the controller enters failure mode.

Output 1 failure transfer, if activated, will perform:

1. If output 1 is configured as proportional control ($PB \neq 0$), and BPLS is selected for O1FT, then output 1 will perform bumpless transfer. Thereafter, the previous averaging value of MV1 will be used for controlling output 1.
2. If output 1 is configured as proportional control ($PB \neq 0$), and a value of 0 to 100.0% is set for O1FT, then output 1 will perform failure transfer. Thereafter, the value of O1FT will be used for controlling output 1.
3. If output 1 is configured as ON-OFF control ($PB=0$), then output 1 will be driven OFF if OFF is set for O1FT and will be driven ON if ON is set for O1FT.

Output 2 failure transfer, if activated, will perform:

1. If OUT2 is configured as COOL, and BPLS is selected for O1FT, then output 2 will perform bumpless transfer. Thereafter, the previous averaging value of MV2 will be used for controlling output 2.
2. If OUT2 is configured as COOL, and a value of 0 to 100.0% is set for O2FT, then output 2 will perform failure transfer. Thereafter, the value of O1FT will be used for controlling output 2.
3. If OUT2 is configured as alarm function, and O2FT is set to OFF, then output 2 will go off. Otherwise, output 2 will go on if O2FT is set to ON.

3-11 Auto-tuning

! For best results the auto-tuning process should be performed near the set point. The process will oscillate around the set point during the tuning process. Set the set point at a lower value if overshooting beyond the normal process value is likely to cause damage.

Auto-tuning is applied in cases of:

- Initial setup for a new process
- The set point is changed substantially from the previous auto-tuning value
- The control result is unsatisfactory

Operation:

1. Do not set a zero value for PB and TI, or the auto-tuning program will be disabled. The LOCK parameter should also be set at NONE.
2. Set the set point to a normal operating value, or a lower value if overshooting beyond the normal process value is likely to cause damage.
3. Press **☐** several times until **A-t** appears on the display (for TEC-220), or an AT indicator on lower-right of screen is lit (for TEC-920).
4. Press and hold **☐** for at least 5 seconds. The AT indicator (for TEC-920) or the display (for TEC-220) will begin to flash indicating the auto-tuning procedure has begun.

NOTE: The ramping function, if used, will be disabled while auto-tuning is taking place.

Auto-tuning mode is disabled as soon as either failure mode or manual control mode is entered.

Procedures:

Auto-tuning can be applied either as the process is warming up (cold start), or when the process has been in a steady state (warm start). After the auto-tuning procedures are completed, the AT indicator will cease to flash and the unit will revert to PID control using its new PID values. The PID values obtained are stored in the nonvolatile memory.

ATER Auto-Tuning Error

If auto-tuning fails an ATER message will appear on the display in the following cases:

- If PB exceeds 9000 (9000 PU, 900.0°F or 500.0°C),
- if TI exceeds 1000 seconds,
- if the set point is changed during the auto-tuning procedure.

Solutions to **ATER**

1. Try auto-tuning again.
2. Don't change the set point value during the auto-tuning procedure.
3. Don't set a zero value for PB and TI.
4. Use manual tuning instead of auto-tuning (see section 3-12).
5. Touch RESET key to reset **ATER** message.

3-12 Manual Tuning

In certain applications auto-tuning may be inadequate for the control requirements. You can try manual tuning for these applications.

If the control performance using auto-tuning is still unsatisfactory, the following rules can be applied for further adjustment of PID values:

Figure 3.9 shows the effects of PID adjustment on process response.

ADJUSTMENT SEQUENCE	SYMPTOM	SOLUTION
(1) Proportional Band (PB)	Slow Response	Decrease PB
	High overshoot or Oscillations	Increase PB
(2) Integral Time (TI)	Slow Response	Decrease TI
	Instability or Oscillations	Increase TI
(3) Derivative Time (TD)	Slow Response or Oscillations	Decrease TD
	High Overshoot	Increase TD

Table 3.2 PID Adjustment Guide

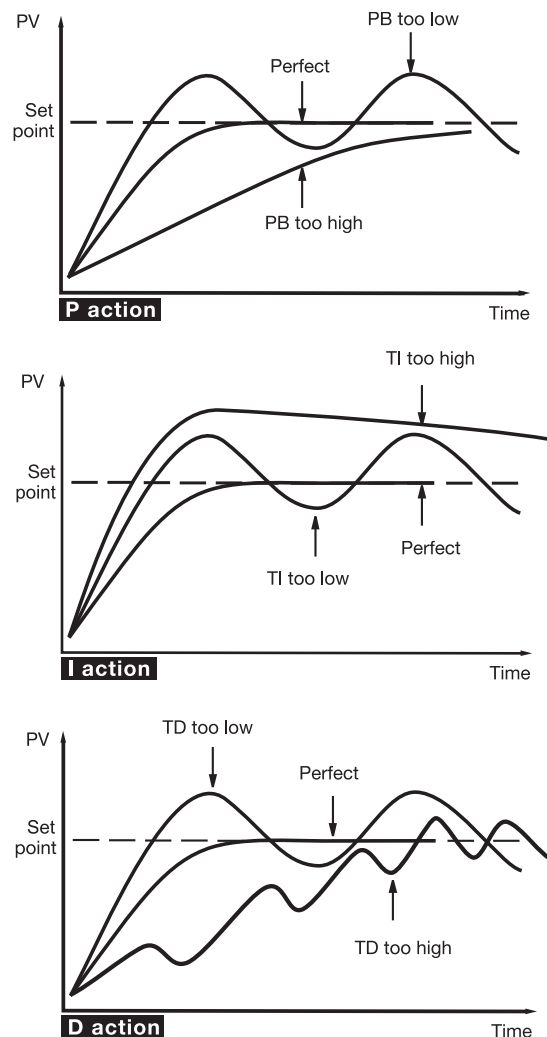







Figure 3.9 Effects of PID Adjustment

3-13 Manual Control

Operation:

To enable manual control, the LOCK parameter should be set to NONE.

Press  several times;  (heating output) or  (cooling output) will appear on the display. Press and hold  for 5 seconds or until the MAN indicator (for TEC-920) or the display (for TEC-220) begins to flash. The controller is now in manual control mode.  indicates output control variable for output 1, and  indicates control variable for output 2. Now you can use the up and down keys to adjust the percentage values for the heating or cooling output.

The controller performs open loop control as long as it stays in manual control mode.

Exit Manual Control

Model TEC-920: Pressing the  key will cause the controller to revert to its normal display mode.

Model TEC-220: Press and release the up and down buttons.

3-14 Data Communication

The controllers support RTU mode of Modbus protocol for data communication. Other protocols are not available for this series.

Two types of interface are available for data communication. These are RS-485 and RS-232. Since RS-485 uses a differential architecture to drive and sense signal instead of a single-ended architecture like the one used for RS-232, RS-485 is less sensitive to noise and more suitable for communication over a longer distance. RS-485 can communicate without error over a 1km distance while RS-232 is not recommended for a distance of over 60 feet (20 meters).

Using a PC for data communication is the most economical method. The signal is transmitted and received through the PC communication port (generally RS-232). Since a standard PC can't support an RS-485 port, a network adapter (such as TEC99001) has to be used to convert RS-485 to RS-232 for a PC if RS-485 is required for data communication. Up to 247 RS-485 units can be connected to one RS-232 port; therefore a PC with four comm ports can communicate with 988 units.

Setup

Enter the setup menu. Select RTU for COMM. Set individual addresses for any units that are connected to the same port. Set the baud rate (BAUD), data bit (DATA), parity bit (PARI) and stop bit (STOP) so that these values are accordant with PC setup conditions.

If you use a conventional 9-pin RS-232 cable instead of TEC99014, the cable should be modified for proper operation of RS-232 communication according to section 2-9 on page 10.

Refer to Chapter 7 for a complete technical description of the Modbus Communications Protocol.

3-15 Process Variable (PV) Retransmission

The TEC-220 controller can output (retransmit) a process value via its retransmission terminals RE+ and RE- provided that the retransmission option is ordered. The correct signal type should be selected for COMM parameter to meet the retransmission option installed. RELO and REHI are set to specify the low scale and high scale values of retransmission.

The TEC-920 does not have this feature.

4-1 Heat Only Control with Dwell Timer

An oven is designed to dry products at 150°C for 30 minutes and then stay unpowered for another batch. A TEC-920 equipped with dwell timer is used for this purpose. The system diagram is shown at right:

To achieve this function, set the following parameters in the setup menu:

```

INPT=K_TC      UNIT=°C
DP=1_DP        OUT1=REVR
O1TY=RELY     CYC1=18.0
O1FT=BPLS     OUT2=TIMR
O2FT=ON
    
```

Auto-tuning is performed at 150°C for a new oven.

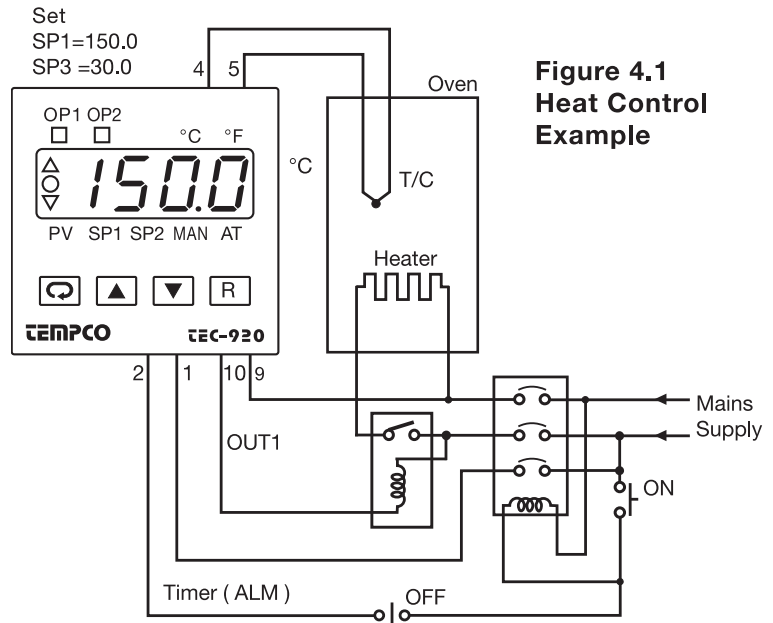
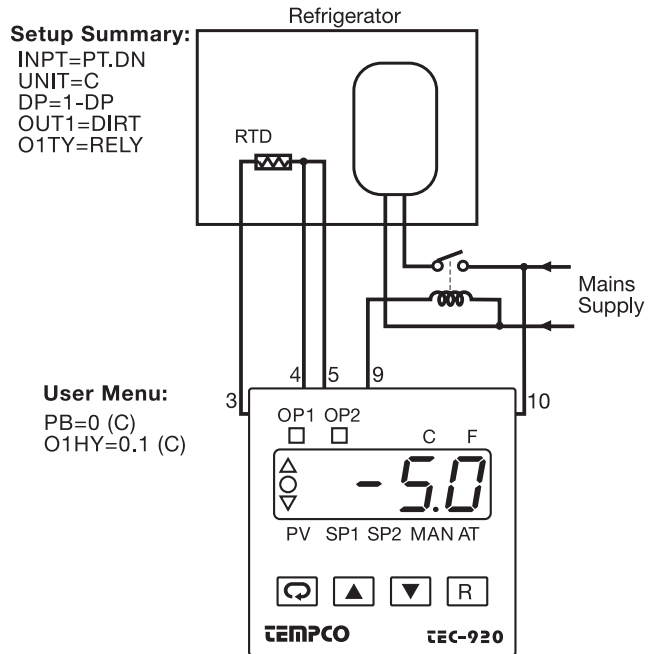

Figure 4.1
Heat Control Example

4-2 Cool Only Control

A TEC-920 is used to control a refrigerator at temperatures below 0°C. This temperature is lower than the ambient, so a cooling action is required. Select DIRT for OUT1. Since output 1 is used to drive a magnetic contactor, the O1TY should be set for RELY. A small temperature oscillation is tolerable, so use ON-OFF control to reduce the over-all cost. To use ON-OFF control, set PB to zero and O1HY at 0.1°C.



Setup Summary:
INPT=PT.DN
UNIT=C
DP=1-DP
OUT1=DIRT
O1TY=RELY

User Menu:
PB=0 (C)
O1HY=0.1 (C)

Figure 4.2 Cooling Control Example

4-3 Heat-Cool Control

An injection mold is required to be controlled at 120°C to ensure a consistent quality for the parts. An oil pipe is buried in the mold. Since plastics are injected at a higher temperature (e.g., 250°C), the circulation oil needs to be cooled as its temperature rises. Here is an example:

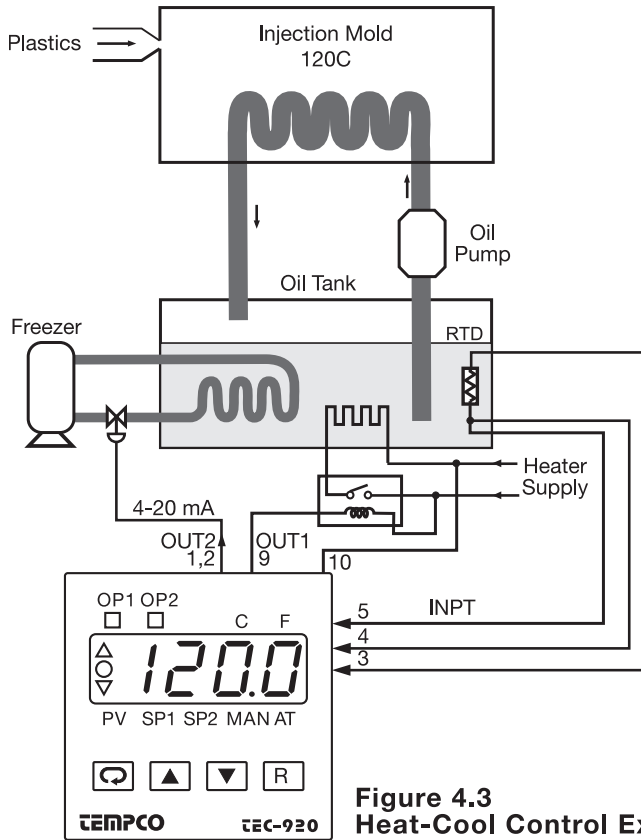

Figure 4.3
Heat-Cool Control Example

The PID heat-cool operation is used for the above example. To achieve this, set the following parameters in the setup menu:

```

INPT=PT.DN
UNIT=°C
DP= 1-DP
OUT1=REVR
O1TY=RELY
CYC1=18.0 (sec.)
O1FT=BPLS
OUT2=COOL
O2TY=4-20
O2FT=BPLS
    
```

Set SV at 120.0°C, CPB at 125(%) and DB at -4.0(%).

Apply auto-tuning at 120°C for a new system to get optimal PID values. See section 3-11.

Adjustment of CPB is related to the cooling medium used. If water is used as the cooling medium instead of oil, the CPB should be set at 250(%). If air is used as the cooling medium instead of oil, the CPB should be set at 100(%). The adjustment of DB is dependent on the system requirements. A higher positive value of DB will prevent unwanted cooling action, but will increase the temperature overshoot, while a lower negative value of DB will result in less temperature overshoot, but will increase unwanted cooling action.

Chapter 6 Specifications

Power

90–250VAC, 47–63 Hz, 10VA, 5W maximum
11–26VAC/VDC, 10VA, 5W maximum

Input

Resolution: 18 bits

Sampling rate: 5 times/second

Maximum rating: -2VDC minimum, 12VDC maximum
(1 minute for mA input)

Temperature effect: $\pm 1.5\mu\text{V}/^\circ\text{C}$ for all inputs except mA input
 $\pm 3.0\mu\text{V}/^\circ\text{C}$ for mA input

Sensor lead resistance effect:

T/C: $0.2\mu\text{V}/\text{ohm}$

3-wire RTD: $2.6^\circ\text{C}/\text{ohm}$ of resistance difference of two leads

2-wire RTD: $2.6^\circ\text{C}/\text{ohm}$ of resistance sum of two leads

Common mode rejection ratio (CMRR): 120dB

Normal mode rejection ratio (NMRR): 55dB

Sensor break detection:

Sensor open for TC, RTD and mV inputs,
Sensor short for RTD input,
Below 1mA for 4–20mA input,
Below 0.25V for 1–5V input,
unavailable for other inputs.

Sensor break responding time:

Within 4 seconds for TC, RTD, and mV inputs, 0.1 second for 4–20mA and 1–5V inputs.

Characteristics:

Type	Range	Accuracy @ 25°C	Input Impedance
J	-120°C to 1000°C (-184°F to 1832°F)	$\pm 2^\circ\text{C}$	2.2 M Ω
K	-200°C to 1370°C (-328°F to 2498°F)	$\pm 2^\circ\text{C}$	2.2 M Ω
T	-250°C to 400°C (-418°F to 752°F)	$\pm 2^\circ\text{C}$	2.2 M Ω
E	-100°C to 900°C (-148°F to 1652°F)	$\pm 2^\circ\text{C}$	2.2 M Ω
B	0°C to 1800°C (32°F to 3272°F)	$\pm 2^\circ\text{C}$ (200°C to 1800°C)	2.2 M Ω
R	0°C to 1767.8°C (32°F to 3214°F)	$\pm 2^\circ\text{C}$	2.2 M Ω
S	0°C to 1767.8°C (32°F to 3214°F)	$\pm 2^\circ\text{C}$	2.2 M Ω
N	-250°C to 1300°C (-418°F to 2372°F)	$\pm 2^\circ\text{C}$	2.2 M Ω
L	-200°C to 900°C (-328°F to 1652°F)	$\pm 2^\circ\text{C}$	2.2 M Ω
PT100 (DIN)	-210°C to 700°C (-346°F to 1292°F)	$\pm 0.4^\circ\text{C}$	1.3 K Ω
PT100 (JIS)	-200°C to 600°C (-328°F to 1112°F)	$\pm 0.4^\circ\text{C}$	1.3 K Ω
mV	-8mV to 70mV	$\pm 0.05\%$	2.2 M Ω
mA	-3mA to 27mA	$\pm 0.05\%$	70.5 Ω
V	-1.3V to 11.5V	$\pm 0.05\%$	650 K Ω

Output 1/Output 2

Relay rating: 2A/240VAC, 200,000 life cycles for resistive load

Pulsed voltage: Source voltage 5V, current limiting resistance 66 Ω .

Linear Output

Resolution: 15 bits

Output regulation: 0.02% for full load change

Output settling time: 0.1 sec. (stable to 99.9 %)

Isolation breakdown voltage: 1000VAC

Temperature effect: $\pm 0.01\%$ of SPAN/ $^\circ\text{C}$

Triac (SSR) Output

Rating: 1A/240 VAC

Inrush current: 20A for 1 cycle

Min. load current: 50mA rms

Max. off-state leakage: 3mA rms

Max. on-state voltage: 1.5VAC rms

Insulation resistance: 1000M Ω min. at 500 VDC

Dielectric strength: 2500VAC for 1 minute

Linear Output Characteristics

Type	Zero Tolerance	Span Tolerance	Load Capacity
4-20mA	3.8-4mA	20-21mA	500 Ω max.
0-20mA	0 mA	20-21mA	500 Ω max.
0 – 5 V	0 V	5 – 5.25 V	10 K Ω min.
1 – 5 V	0.9 – 1 V	5 – 5.25 V	10 K Ω min.
0 – 10 V	0 V	10 – 10.5 V	10 K Ω min.

DC Voltage Supply Characteristics (Installed at Output 2)

Type	Tolerance	Max. Output Current	Ripple Voltage	Isolation Barrier
20 V	$\pm .5\text{ V}$	25 mA	0.2 Vp-p	500 VAC
12 V	$\pm 0.3\text{ V}$	40 mA	0.1 Vp-p	500 VAC
5 V	$\pm 0.15\text{ V}$	80 mA	0.05 Vp-p	500 VAC

Specifications, continued...

Output 2 functions: Dwell timer
Deviation high/low alarm
Deviation band high/low alarm
PV high/low alarm
PID cooling control

Alarm modes: Normal, latching, hold, latching/hold.

Dwell timer: 0.1–4553.6 minutes

Data Communication

Interface: RS-232 (1 unit), RS-485 (up to 247 units)

Protocol: Modbus protocol RTU mode

Address: 1–247

Baud rate: 0.3 - 38.4Kbits/sec

Data bits: 7 or 8 bits

Parity bit: None, even or odd

Stop bit: 1 or 2 bits

Communication buffer: 160 bytes

Analog Retransmission

Output Signal: 4-20 mA, 0-20 mA, 0-5V, 1-5V, 0-10V

Resolution: 15 bits

Accuracy: $\pm 0.05\%$ of span $\pm 0.0025\%/^{\circ}\text{C}$

Load Resistance: 0-500 ohms (for current output)
10K ohms minimum (for voltage output)

Output Regulation: 0.01% for full load change)

User Interface

Single 4-digit LED display

Keypad: 3 keys for TEC-220, 4 keys for TEC-920

Programming port: For automatic setup, calibration, and testing

Communication port: Connection to PC for supervisory control

Control Mode

Output 1: Reverse (heating) or direct (cooling) action

Output 2: PID cooling control, cooling P band 50~300% of PB, dead band -36.0-36.0% of PB

ON-OFF: 0.1-90.0 ($^{\circ}\text{F}$) hysteresis control (P band=0)

P or PD: 0–100.0% offset adjustment

PID: Fuzzy logic modified
Proportional band 0.1-900.0 $^{\circ}\text{F}$
Integral time 0–1000 seconds
Derivative time 0–360.0 seconds

Cycle time: 0.1–90.0 seconds

Manual control: Heat (MV1) and cool (MV2)

Auto-tuning: Cold start and warm start

Failure mode: Auto-transfer to manual mode while sensor break or A-D converter damage

Ramping control: 0–900.0 $^{\circ}\text{F}/\text{minute}$ or
0–900.0 $^{\circ}\text{F}/\text{hour}$ ramp rate

Digital Filter

Function: First order

Time constant: 0, 0.2, 0.5, 1, 2, 5, 10, 20, 30, 60 seconds programmable

Environmental and Physical

Operating temperature: 14 $^{\circ}\text{F}$ (-10°C) to 122 $^{\circ}\text{F}$ (50°C)

Storage temperature: -40 $^{\circ}\text{F}$ (-40°C) to 140 $^{\circ}\text{F}$ (60°C)

Humidity: 0 to 90% RH (non-condensing)

Insulation resistance: 20Mohms min. (at 500VDC)

Dielectric strength: 2000VAC, 50/60 Hz for 1 minute

Vibration resistance: 10–55 Hz, 10 m/s \approx for 2 hours

Shock resistance: 200m/s \approx (20g)

Moldings: Flame retardant polycarbonate

Dimensions:

TEC-220 — 1-3/64" (26.5 mm) H \times 2" (50 mm) W
 \times 4-3/8" (110.5 mm) D
Depth behind panel: 3-7/8" (98 mm)

TEC-920 — 1-7/8" (48 mm) H \times 1-7/8" (48 mm) W
 \times 3-3/4" (94 mm) D
Depth behind panel: 3-3/8" (86 mm)

Weight: TEC-220 — .26 lbs. (120 grams)
TEC-920 — .31 lbs. (140 grams)

Approval Standards

Safety: UL61010C-1
EN61010-1 (IEC1010-1)

Protective class:

IP65 front panel for TEC-220
IP30 front panel for TEC-920, all indoor use
IP20 for terminals and housing with protective cover.
All indoor use.

EMC: EN61326

Chapter 7 Modbus Communications

This chapter specifies the Modbus Communications protocol as RS-232 or RS-485 interface module is installed. Only RTU mode is supported. Data is transmitted as eight-bit binary bytes with 1 start bit, 1 stop bit and optional parity checking (None, Even or Odd). Baud rate may be set to 2400, 4800, 9600, 14400, 19200, 28800 and 38400.

7-1 Functions Supported

Only function 03, 06 and 16 are available for this series of controllers. The message formats for each function are described as follows:

Function 03: Read Holding Registers

Query: (from Primary)

Secondary address (0-255)

Function code (3)

Starting address of register Hi (0)

Starting address of register Lo
(0-79, 128-131)

No. of words Hi (0)

No. of words Lo (1-79)

CRC16 Hi

CRC16 Lo

Response: (from Secondary)

←

←

Byte count

Data 1 Hi

Data 1 Lo

Data 2 Hi

Data 2 Lo

•

•

•

•

CRC16 Hi

CRC16 Lo

Function 06: Preset Single Register

Query: (from Primary)

Secondary address (0-255)

Function code (6)

Register address Hi (0)

Register address Lo (0-79, 128-131)

Data Hi

Data Lo

CRC16 Hi

CRC16 Lo

Response: (from Secondary)

←

←

←

←

←

←

←

←

Function 16: Preset Multiple Registers

Query: (from Primary)

Secondary address (0-255)

Function code (16)

Starting address of register Hi (0)

Starting address of register Lo (0-79, 128-131)

No. of words Hi (0)

No. of words Lo (1-79)

Byte count (2-158)

Data 1 Hi

Data 1 Lo

Data 2 Hi

Data 2 Lo

•

•

•

•

•

CRC16 Hi

CRC16 Lo

Response: (from Secondary)

←

←

←

←

←

←

CRC16 Hi

CRC16 Lo

7-2 Exception Responses

If the controller receives a message which contains a corrupted character (parity check error, framing error etc.), or if the CRC16 check fails, the controller ignores the message. However, if the controller receives a syntactically correct message which contains an illegal value, it will send an exception response, consisting of five bytes as follows:

secondary address + offset function code + exception code + CRC16 Hi +CRC16 Lo

Where the offset function code is obtained by adding the function code with 128 (ie. function 3 becomes H'83), and the exception code is equal to the value contained in the following table:

Exemption Code	Name	Cause
1	Bad Function Code	Function code is not supported by the controller
2	Illegal data address	Register address out of range
3	Illegal data value	Data value out of range or attempt to write a read-only or protected data

7-3 Parameter Table

Register Address	Parameter Notation	Parameter	Scale Low	Scale High	Notes
0	SP1	Set Point 1	*4	*4	R/W
1	SP2	Set Point 2	*7	*7	R/W
2	SP3	Set Point 3	*6	*6	R/W
3	LOCK	Lock code	0	65535	R/W
4	INPT	Input sensor selection	0	65535	R/W
5	UNIT	Measuring unit	0	65535	R/W
6	DP	Decimal point position	0	65535	R/W
7	INLO	Low scale value for linear input	*4	*4	R/W
8	INHI	High scale value for linear input	*4	*4	R/W
9	SP1L	Low limit of SP1	*4	*4	R/W
10	SP1H	High Limit of SP1	*4	*4	R/W
11	SHIF	PV shift value	*4	*4	R/W
12	FILT	Filter time constant	0	65535	R/W
13	DISP	Display form	0	65535	R/W
14	PB	P (proportional) band	*5	*5	R/W
15	TI	Integral time	0	65535	R/W
16	TD	Derivative time	0.0	6553.5	R/W
17	OUT1	Output 1 function	0	65535	R/W
18	O1TY	Output 1 signal type	0	65535	R/W
19	O1FT	Output 1 failure transfer	-1999.9	4553.6	R/W
20	O1HY	Output 1 ON-OFF hysteresis	*5	*5	R/W
21	CYC1	Output 1 cycle time	0.0	6553.5	R/W
22	OFST	Offset value for P control	0.0	6553.5	R/W
23	RAMP	Ramp function	0	65535	R/W
24	RR	Ramp rate	*5	*5	R/W
25	OUT2	Output 2 function	0	65535	R/W
26	RELO	Retransmission low scale value	*4	*4	R/W
27	O2TY	Output 2 signal type	0	65535	R/W
28	O2FT	Output 2 failure transfer	-1999.9	4553.6	R/W
29	O2HY	Output 2 ON-OFF hysteresis	*5	*5	R/W
30	CYC2	Output 2 cycle time	0.0	6553.5	R/W
31	CPB	Cooling P band	0	65535	R/W
32	DB	Heating-cooling dead band	-1999.9	4553.6	R/W

Register Address	Parameter Notation	Parameter	Scale Low	Scale High	Notes
33	ALFN	Alarm Function	0	65535	R/W
34	REHI	Retransmission high scale value	*4	*4	R/W
35	ALMD	Alarm operation mode	0	65535	R/W
36	ALHY	Alarm hysteresis	*5	*5	R/W
37	ALFT	Alarm failure transfer	0	65535	R/W
38	COMM	Communication function	0	65535	R/W
39	ADDR	Address	0	65535	R/W
40	BAUD	Baud rate	0	65535	R/W
41	DATA	Data bit count	0	65535	R/W
42	PARI	Parity bit	0	65535	R/W
43	STOP	Stop bit count	0	65535	R/W
44	SEL1	Selection 1	0	65535	R/W
45	SEL2	Selection 2	0	65535	R/W
46	SEL3	Selection 3	0	65535	R/W
47	SEL4	Selection 4	0	65535	R/W
48	SEL5	Selection 5	0	65535	R/W
49	SEL6	Selection 6	0	65535	R/W
50	SEL7	Selection 7	0	65535	R/W
51	SEL8	Selection 8	0	65535	R/W
52	ADLO	mV calibration low coefficient	-1999.9	4553.6	R/W
53	ADHI	mV calibration high coefficient	-1999.9	4553.6	R/W
54	RTDL	RTD calibration low coefficient	-1999.9	4553.6	R/W
55	RTDH	RTD calibration high coefficient	-1999.9	4553.6	R/W
56	CJLO	Cold junction calibration low coefficient	-199.99	455.36	R/W
57	CJHI	Cold junction calibration high coefficient	-1999.9	4553.6	R/W
58	DATE	Date code	0	65535	R/W
59	SRNO	Serial number	0	65535	R/W
60	HOUR	Working hours of the controller	0	65535	R/W
61	BPL1	Bumpless transfer of OP1	0	65535	R
62	BPL2	Bumpless transfer of OP2	0.00	655.35	R
63	CJCL	Cold junction signal low	0.000	65.535	R
64, 128	PV	Process value	*4	*4	R
65, 129	SV	Current set point value	*4	*4	R
66 130	MV1	OP1 control output value	0.00	655.35	Read only unless in manual control
67 131	MV2	OP2 control output value	0.00	655.35	Read only unless in manual control
68	TIMER	Remaining time of dwell timer	-1999.9	4553.6	R
69	EROR	Error code *1	0	65535	R
70	MODE	Operation mode and alarm status *2	0	65535	R
71, 140	PROG	Program code *3	0.00	655.35	R
72	CMND	Command code	0	65535	R/W
73	JOB1	Job code	0	65535	R/W
74	JOB2	Job code	0	65535	R/W
75	JOB3	Job code	0	65535	R/W
76	CJCT	Cold Junction Temperature	-199.99	455.36	R
77		Reserved	0	65535	R
78		Reserved	0	65535	R
79		Reserved	0	65535	R

*1 The error code is shown in the first column of Table A.1 page 28.

*2 Definition for the value of MODE register:

H'000X = Normal mode

H'010X = Calibration mode

H'020X = Auto-tuning mode

H'030X = Manual control mode

H'040X = Failure mode

H'0X00 = Alarm status is off

H'0x01 = Alarm status is on

The alarm status is shown in MV2 instead of MODE for models TEC-220 and TEC-920.

*3 The PROG Code is defined in the following table

Model No.	TEC-9100	TEC-8100	TEC-4100	TEC-7100	TEC-220	TEC-920
PROG Code	6.XX	11.XX	12.XX	13.XX	33.XX	34.XX

(xx denotes the software version)

*4 The scale high/low values are defined in the following table for SP1, INLO, INHI, SP1L, SP1H, SHIF, PV, SV, RELO and REHI:

Conditions	Non-linear input	Linear input DP = 0	Linear input DP = 1	Linear input DP = 2	Linear input DP = 3
Scale low	-1999.9	-19999	-1999.9	-199.99	-19.999
Scale High	4553.6	45536	4553.6	455.36	45.536

*5 The scale high/low values are defined in the following table for PB, O1HY, RR, O2HY, and ALHY:

Conditions	Non-linear input	Linear input DP = 0	Linear input DP = 1	Linear input DP = 2	Linear input DP = 3
Scale low	0.0	0	0.0	0.00	0.000
Scale High	6553.5	65535	6553.5	655.35	65.535

*6 The scale high/low values are defined in the following table for SP3:

Conditions	ALFN=1 (TIMR)	Non-linear input	Linear input DP = 0	Linear input DP = 1	Linear input DP = 2	Linear input DP = 3
Scale low	-1999.9	-1999.9	-19999	-1999.9	-199.99	-19.999
Scale High	4553.6	4553.6	45536	4553.6	455.36	45.536

*7 The scale high/low values are defined in the following table for SP2:

For TEC-220 and TEC-920

Conditions	OUT2=1 (TIMR)	Non-linear input	Linear input DP = 0	Linear input DP = 1	Linear input DP = 2	Linear input DP = 3
Scale low	-1999.9	-1999.9	-19999	-1999.9	-199.99	-19.999
Scale High	4553.6	4553.6	45536	4553.6	455.36	45.536

For TEC-9100, TEC-8100, TEC-7100 and TEC-4100:

Conditions	Non-linear input	Linear input DP = 0	Linear input DP = 1	Linear input DP = 2	Linear input DP = 3
Scale low	-1999.9	-19999	-1999.9	-199.99	-19.999
Scale High	4553.6	45536	4553.6	455.36	45.536

7-4 Data Conversion

The word data are regarded as unsigned (positive) data in the Modbus message. However, the actual value of the parameter may be a negative value with decimal point. The high/low scale values for each parameter are used for the purpose of such conversion.

Let M = Value of Modbus message

A = Actual value of the parameter

SL = Scale low value of the parameter

SH = Scale high value of the parameter

$$M = \left(\frac{65535}{SH - SL} \right) \times (A - SL)$$

$$A = \left(\frac{SH - SL}{65535} \right) \times (M + SL)$$

7-5 Communication Examples:

Example 1: Download the default values via the programming port

The programming port can perform Modbus communications regardless of the incorrect setup values of address, baud, parity, stop bit, etc. It is especially useful during the first time configuration for the controller. The host must be set with 9600 baud rate, 8 data bits, even parity and 1 stop bit.

The Modbus message frame with hexadecimal values is shown as follows:

01	10	00	00	00	34	68	4F	19	4E	83	4E	83	00	00
Addr.	Func.	Starting Addr.		No. of words		Bytes		SP1=25.0		SP2=10.0		Sp3=10.0		LOCK = 0

00	01	00	00	00	01	4D	6D	51	C4	4D	6D	63	21
INPT = 1		UNIT = 0		DP = 1		INLO = -17.8		INHI = 93.3		SP1L = -17.8		SP1H = 537.8	

4E	1F	00	02	00	00	00	64	00	64	00	FA	00	00
SHIF = 0.0		FILT = 2		DISP = 0		PB = 10.0		TI = 100		TD = 25.0		OUT1 = 0	

00	00	4E	1F	00	01	00	B4	00	FA	00	00	00	00
O1TY = 0		O1FT = 0		O1HY = 0.1		CYC1 = 18.0		OFST = 25.0		RAMP = 0		RR = 0.0	

00	02	4E	1F	00	00	4E	1F	00	01	00	B4	00	64
OUT2 = 2		RELO = 0.0		O2TY = 0		O2FT = 0		O2HY = 0.1		CYC2 = 18.0		CPB = 100	

4E	1F	00	02	52	07	00	00	00	01	00	00	00	01
DB = 0		ALFN = 2		REHI = 100.0		ALMD = 0		ALHY = 0.1		ALFT = 0		COMM = 1	

00	01	00	02	00	01	00	00	00	00	00	02	00	03
ADDR = 1		BAUD = 2		DATA = 1		PARI = 0		STOP = 0		SEL1 = 2		SEL2 = 3	

00	04	00	06	00	07	00	08	00	0A	00	11	Hi	Lo
SEL3 = 4		SEL4 = 6		SEL5 = 7		SEL6 = 8		SEL7 = 10		SEL8 = 17		CRC16	

Example 2: Read PV, SV, MV1 and MV2

Send the following message to the controller via the COMM port or programming port:

	03	00	H'40 H'80	00	04	Hi	Lo
Addr.	Func.	Starting Addr.	No. of words		CRC16		

Example 4: Enter Auto-tuning Mode

Query

	06	00	H'48	H'68	H'28	Hi	Lo
Addr.	Func.	Register Addr.	Data Hi/Lo		CRC16		

Example 6: Read All Parameters

Query

Example 3: Perform Reset Function

(same effect as pressing [R] key)

Query

	06	00	H'48	H'68	H'25	Hi	Lo
Addr.	Func.	Register Addr.	Data Hi/Lo		CRC16		

Example 5: Enter Manual Control Mode

Query

	06	00	H'48	H'68	H'27	Hi	Lo
Addr.	Func.	Register Addr.	Data Hi/Lo		CRC16		

Example 7: Modify the Calibration Coefficient

Preset the CMND register with 26669 before attempting to change the calibration coefficient.

Table A.1 Error Codes and Corrective Actions

Error Code	Display Symbol	Error Description	Corrective Action
4	<i>Er 04</i>	Illegal setup values being used: Before COOL is used for OUT2, DIRT (cooling action) has already been used for OUT1, or PID mode is not used for OUT1 (that is, PB=0 and/or TI=0)	Check and correct setup values of OUT2, PB, TI and OUT1. If OUT2 is required for cooling control, the control should use PID mode (PB≠0, TI≠0) and OUT1 should use reverse mode (heating action). Otherwise, don't use OUT2 for cooling control.
10	<i>Er 10</i>	Communication error: bad function code	Correct the communication software to meet the protocol requirements.
11	<i>Er 11</i>	Communication error: register address out of range	Don't issue an over-range register address to the slave.
14	<i>Er 14</i>	Communication error: attempt to write a read-only data or a protected data	Don't write a read-only data or a protected data to the slave.
15	<i>Er 15</i>	Communication error: write a value which is out of range to a register	Don't write an over-range data to the slave register.
26	<i>AtEr</i>	Fail to perform auto-tuning function	<ol style="list-style-type: none"> 1. The PID values obtained after auto-tuning procedure are out of range. Retry auto-tuning. 2. Don't change set point value during auto-tuning procedure. 3. Use manual tuning instead of auto-tuning. 4. Don't set a zero value for PB. 5. Don't set a zero value for TI. 6. Press RESET key
29	<i>EEPE</i>	EEPROM can't be written correctly	Return to factory for repair.
30	<i>CJEr</i>	Cold junction compensation for thermocouple malfunction	Return to factory for repair.
39	<i>SbEr</i>	Input sensor break, or input current below 1 mA if 4-20 mA is selected, or input voltage below 0.25V if 1-5V is selected	Replace input sensor.
40	<i>AdEr</i>	A to D converter or related component(s) malfunction	Return to factory for repair.

RETURNS

No product returns can be accepted without a completed Return Material Authorization (RMA) form.

TECHNICAL SUPPORT

Technical questions and troubleshooting help is available from Tempco. When calling or writing please give as much background information on the application or process as possible.

E-mail: techsupport@tempco.com

Phone: 630-350-2252

800-323-6859

Note: Information in this manual was deemed correct at the time of printing. The policy of Tempco is one of continuous development and product improvement, and we reserve the right to modify specifications and designs without prior notice. Not responsible for typographical errors.

NOTES

Custom Manufacturer Since 1972

ELECTRIC HEATING ELEMENTS • TEMPERATURE CONTROLS • SENSORS • PROCESS HEATING SYSTEMS

HEAT THINGS UP!

With Thousands of Design Variations
We Make Everything You Need.

Band Heaters	Cartridge Heaters
Cast-In Heaters	Coil & Cable Heaters
Radiant Heaters	Strip Heaters
Flexible Heaters	Tubular Heaters
Process Heaters	Instrumentation
Temperature Control	Temperature Sensors



607 N. Central Avenue Wood Dale, IL 60191-1452 USA
P: 630-350-2252 Toll Free: 800-323-6859
F: 630-350-0232 E: info@tempco.com
www.tempco.com