

# TEMPCO®

## USER MANUAL

### TEC-401, TEC-402, TEC-404, TEC-405

1/4 DIN Solid State Temperature Controller –  
Relay Output–Solid State Output – For Heating



TEC-401 & TEC-402



TEC-404 & TEC-405



**NOTE:** ON/OFF control must be used for valves & Solenoids. Proportional is common for electric heaters.

## Specifications

Temperature controls in this series are designed to fit panel cutouts that are 3.625" (92 mm) square. A minimum depth of 3" is required to provide clearance for rear terminal connections. All models have the following specifications in common:

### Input

Thermocouple (T/C) . . . . .Type K, J. See Control label.  
RTD . . . . .Three-wire PT100 ohm DIN or JIS.  
Cold junction compensation . . . . .Automatic  
Input break protection . . . . .Built-in, upscale on open sensor and output off.  
Input impedance . . . . .10M ohm  
Common mode rejection (CMR) . . .CMRR 120dB, min.  
Normal mode rejection (NMR) . . . .NMRR 60dB, min. (60Hz)

### Control Output

Relay Rating . . . . .5 Amp, 240VAC maximum resistive load  
Optional:  
SSR Drive . . . . .Pulsed DC, 20V at 20 mA maximum  
Current Loop . . . . .4–20mA, 0–20mA, Maximum Load: 500 |  
Voltage . . . . .0-10 VDC, Maximum Load: 500K |  
Relay—Alarm . . . . .Relay output, 2 amps / 240VAC maximum, resistive load

### Control Modes

On-Off . . . . .Differential 1% of span.  
Proportional . . . . .Proportional Band fixed at 2.2% of span. Proportional Cycle time  
20 seconds for relay controls, 1 second for SSR controls.

### Set Point

Resolution . . . . .Analog SP: 0.2% of full scale range. Digital SP: least significant digit.  
Accuracy . . . . .±2% of span  
Repeatability . . . . .±0.1% of full scale range.  
Manual reset . . . . .2.6% of full scale range, adjustable.

### Power

Rating . . . . .TEC-401, 402: 100-130VAC 50/60Hz or 200-240VAC 50/60Hz.  
. . . . .TEC-404, 405: 90–264VAC 50/60Hz., 20-32VAC 50/60Hz., 20-32VDC.  
Consumption . . . . .Less than 5VA

### Environmental and Physical

Operating Temperature . . . . .32–122°F (0–50°C)  
Humidity . . . . .10–90% RH (non-condensing)  
Insulation . . . . .20M ohm min. (500VDC)  
Breakdown. . . . .2000VAC, 50/60Hz, 1 minute  
Vibration. . . . .10–55Hz, amplitude 1.0mm  
Shock. . . . .660ft/s≈ (20g)  
Dimensions . . . . .3.75" x 3.75" x 2.625" (96 mm x 96 mm x 67 mm) H x W x D  
Depth behind panel. . . . .2.0625" (52 mm)  
Panel cutout. . . . .3.625" square (92 mm square)  
Weight . . . . .TEC-401, 402: 14oz (400g), TEC-404, 405: 10oz (285g)  
DIN case . . . . .Plastic full plug-in construction with screw terminals on rear and  
adjustable brackets for panel mounting.

## WARNING:

Failure of the thermocouple-RTD sensor, heater output relay, temperature control, or other devices can result in severe damage to a product while in process, melting of the heater, or a damaging fire. An over-temperature protection device such as our TEC-410 or TEC-910 must be included in your process that will remove all power from the heater circuit if any of the above failures occur. It is recommended that this device be classified as an FM safety control. Failure to install such a device where a potential hazard exists could result in damage to equipment and property, and severe injury to personnel.

## NOTE:

It is strongly recommended that a process should incorporate a **LIMIT CONTROL** such as the **TEC-910** which will shut down the equipment at a preset process condition in order to preclude possible damage to products or system.

## Mounting

When mounting one of these instruments, make sure the control and the ambient temperature remain within the 10–125°F range. The control may be mounted in any position. Once the control has been inserted into the panel, use the two mounting brackets provided with the unit to secure it. Use light to moderate pressure.

### Mounting Dimensions

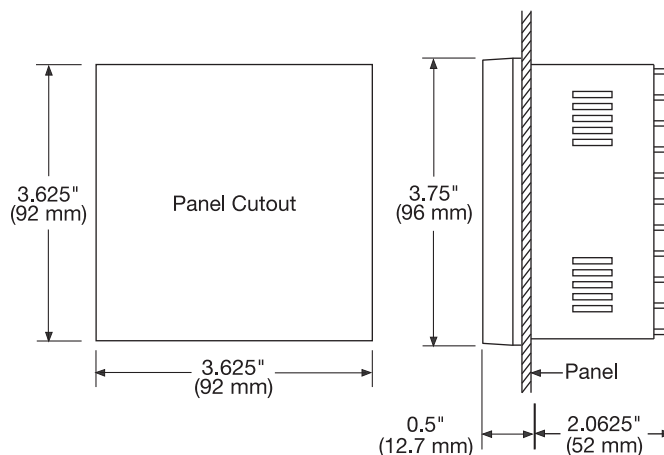

### Manual Reset Adjustment (does not apply to TEC-401)

The reset adjustment is located on the front of the control. Approximately half an hour after adjusting the set point, when the process stabilizes, it may become necessary to adjust "reset" as well. Start with the reset adjustment pointing to zero. If the temperature indication stabilizes above the set point, adjust the reset to the "minus" side; if the temperature stabilizes below the set point, adjust to the "plus" side. Continue making adjustments until the temperature indication stabilizes at the set point. Make sure to allow 15 minutes between adjustments for stabilization.

# Wiring

All wiring should be performed by qualified electricians and conform to local and national codes.

When wiring the thermocouple, make sure that the thermocouple and extension wire conform to the thermocouple type specified by the instrument. The thermocouple and the extension wires must have the same polarity and be the same alloy. For accurate measurements, the total lead resistance should not exceed 100 ohms.

For American thermocouples the red lead is negative.

To assure effective lead resistance compensation when wiring three wire RTDs (Resistance Temperature Detectors), make sure that all of the leads that connect to the controller are the same gauge and composition. Connect the two common wires of the three wire RTD to terminals 17 and 18. When using a two wire RTD, install a jumper between terminals 17 and 18.



**Wiring Diagram 1**  
TEC-401, TEC-402  
Relay Output

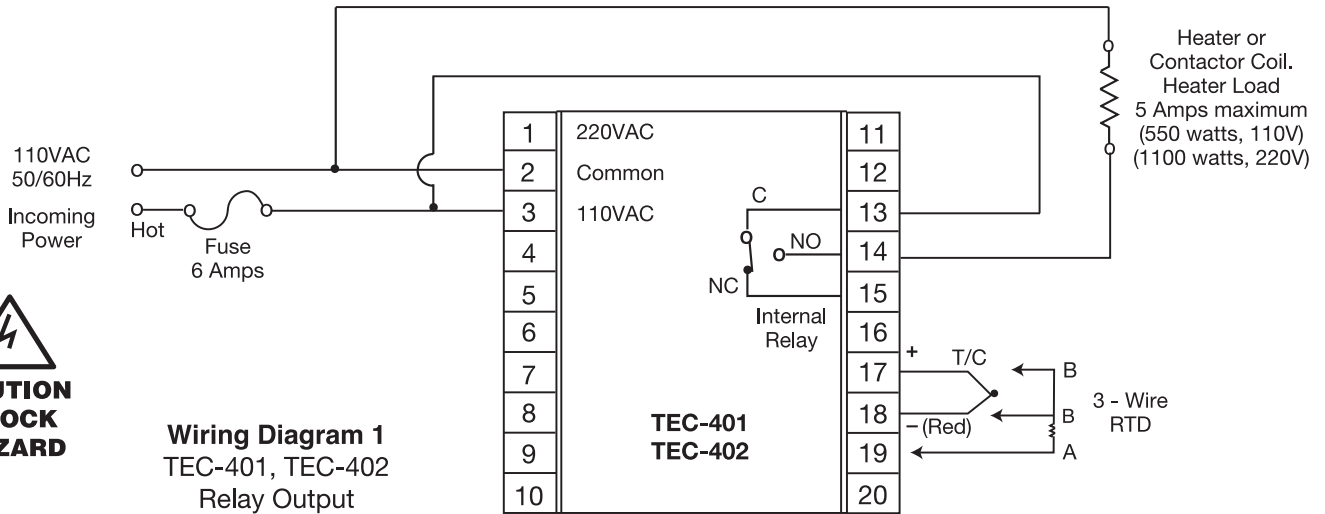

**Wiring Diagram 2**  
TEC-401, TEC-402  
0-24VDC output for Solid State Relay  
(Also can be used for control with  
4-20mA outputs)

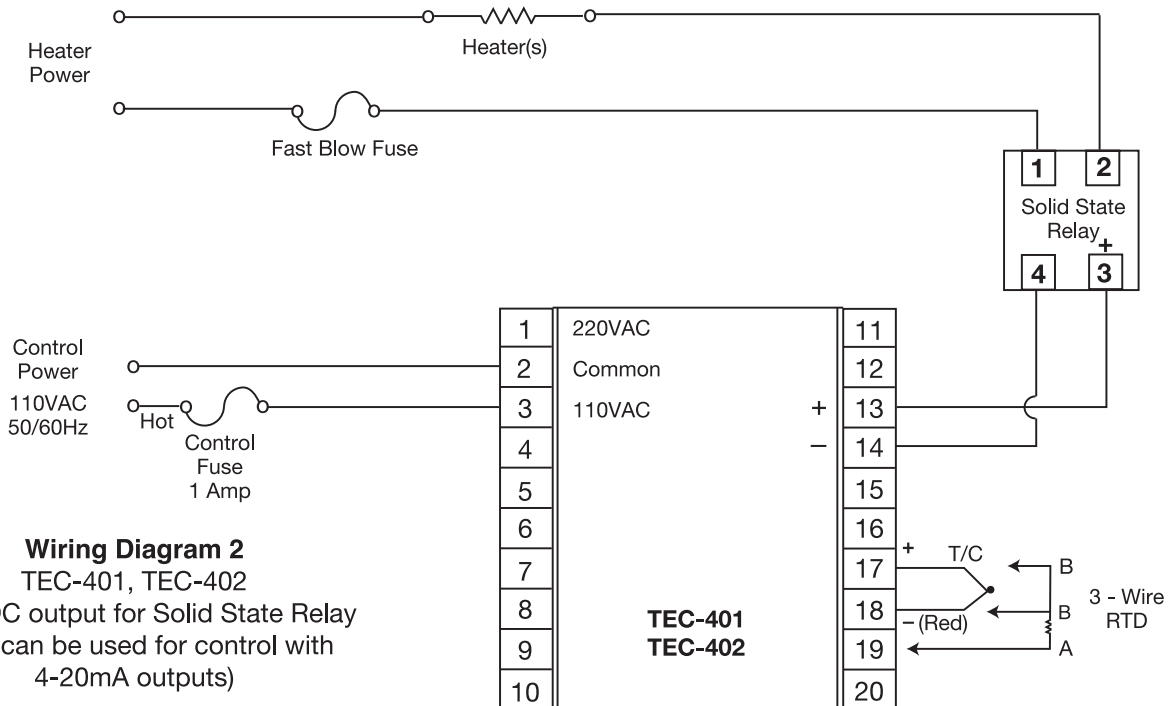

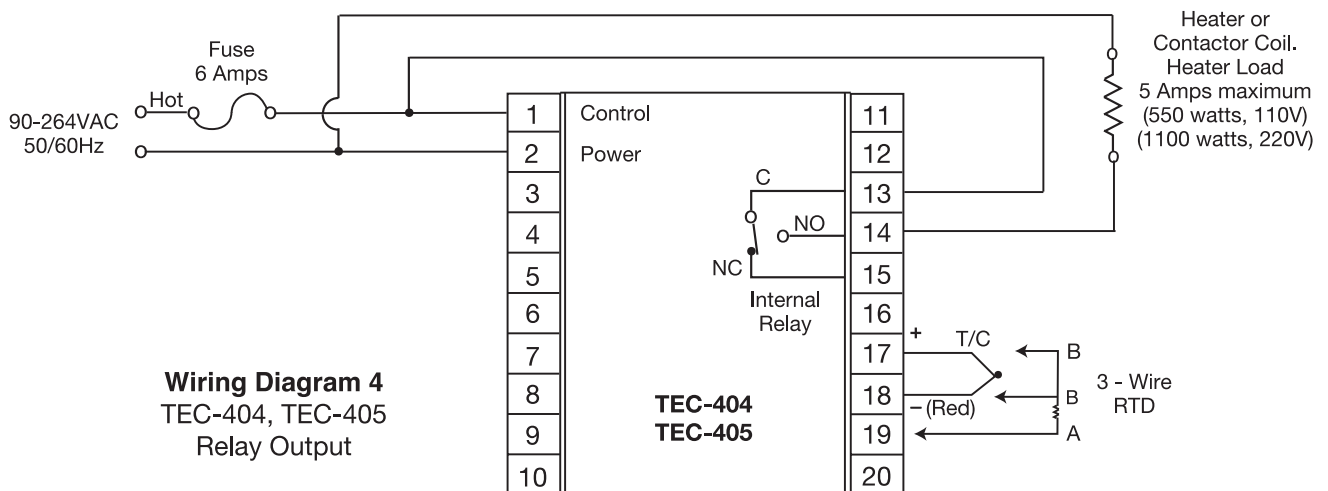
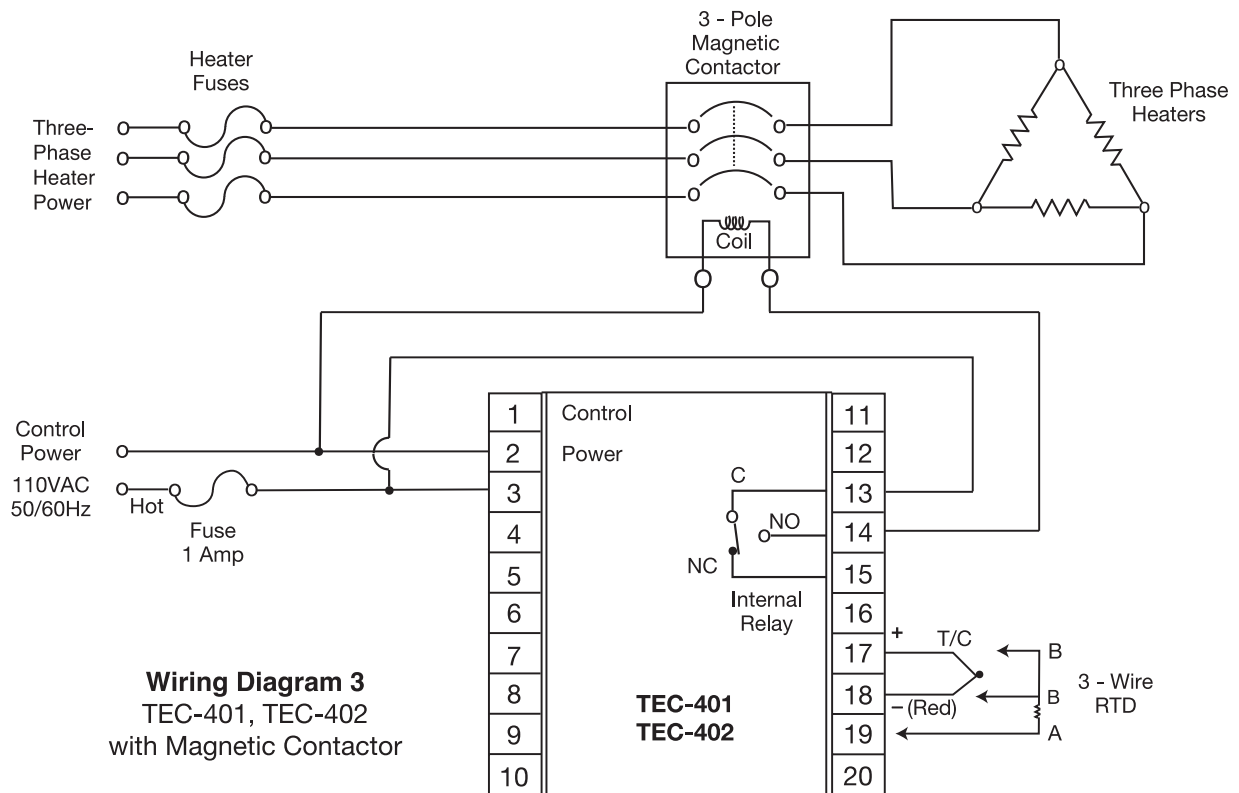

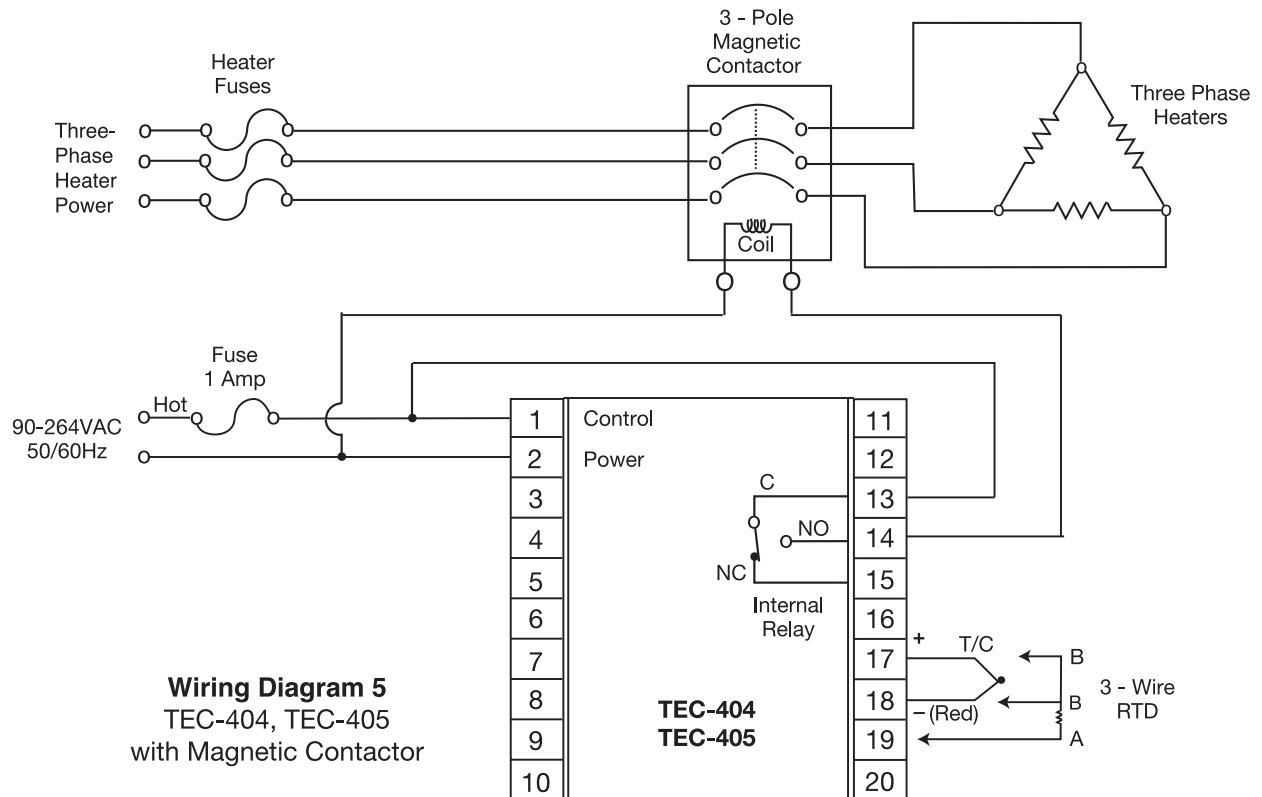

**Wiring Diagram 5**  
TEC-404, TEC-405  
with Magnetic Contactor

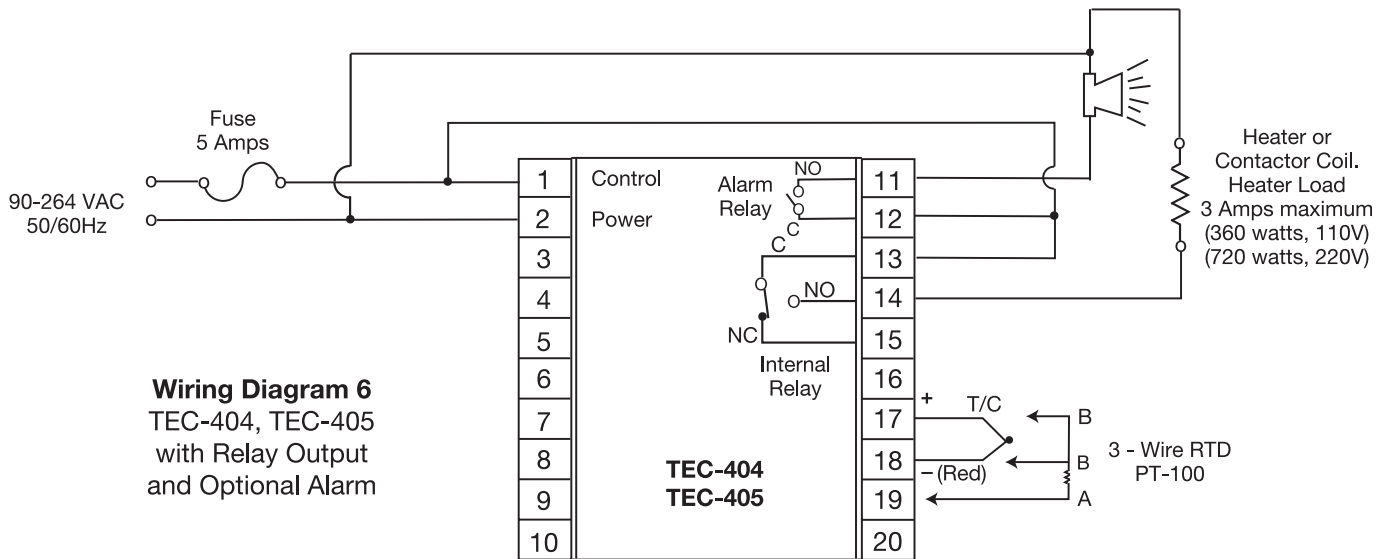

**Wiring Diagram 6**  
TEC-404, TEC-405  
with Relay Output  
and Optional Alarm

## WARNINGS:

- Dangerous voltages may be present in these instruments. Before installation or troubleshooting, switch off and isolate power to all equipment. If a unit is suspected of being faulty, it should be removed by qualified personnel and returned to Tempco for evaluation. These units do not contain any user serviceable components.
- To minimize the risk of fire or shock hazards, avoid exposing these instruments to rain or excessive moisture.
- Do not use these instruments in areas that are prone to hazardous conditions such as excessive shock, vibration, dirt, moisture, corrosive gases, or oil. The ambient temperature of the areas should not exceed the maximum rating specified.

## Wiring Precautions:

- Before wiring, verify the correct model number and options on the label. Switch off the power while checking.
- Care must be taken to ensure that the maximum voltage rating specified on the label is not exceeded.
- It is recommended that the power for these units be protected by fuses or circuit breakers rated at the minimum value possible.
- All units should be installed in a suitable enclosure to prevent live parts from being accessible to human hands and metal tools. Metal enclosures and/or subpanels should be grounded in accordance with national and local codes.
- All wiring must conform to appropriate standards of good practice and local codes and regulations. Wiring must be suitable for the voltage, current, and temperature rating of the system.
- Beware not to over-tighten the terminal screws. The torque should not exceed 1 N-m (8.9 lb-in or 10 KgF-cm).
- Unused control terminals should not be used as jumper points as they may be internally connected, causing damage to the unit.
- Verify that the ratings of the output devices and the inputs as specified are not exceeded.
- Except for thermocouple wiring, all wiring should use stranded copper conductor with a maximum gage of 14 AWG.
- Electrical power in industrial environments contains a certain amount of noise in the form of transient voltage and spikes. This electrical noise can adversely affect the operation of microprocessor-based controls. For this reason the use of shielded thermocouple extension wire which connects the sensor to the controller is strongly recommended. This wire is a twisted-pair construction with foil wrap and drain wire. The drain wire is to be attached to ground in the control panel only.

## General Operation

Adjust the set point to the temperature desired using the analog knob (TEC-401, 402, 404) or the digital set point adjuster (TEC-405). The “OUT” lamp will glow red, indicating that the control is calling for heat, and the relay is closed. As the process temperature approaches the set point, the control will begin to cycle the heaters on and off. When the heater load is turned off, the “OUT” lamp will glow green (TEC-401, 402) or turn off (TEC-404, 405).

**NOTE:** If the controller is configured with a 4–20mA output, then the “OUT” LED will always be in the on position.

## Temperature Indication

All controls: SV=set point value PV=process value

TEC-401: Temperature is indicated by red/green “OUT” LED only. When the lamp changes from red to green, the set point has been reached.

TEC-402: Temperature is indicated by deviation meter labeled in percent. The meter is calibrated in percent of full scale temperature, -10% to +10%, and indicates process deviation from the set point.

TEC-404, 405: Actual process temperature is indicated on the digital display.

## Alarm Operation (Optional)

The TEC-402, 404, and 405 have the option of coming equipped with a form-A relay that can be used as a deviation alarm. It is called a deviation alarm because the alarm set point maintains the same deviation from the control set point, so if the control set point is changed, the alarm set point will change with it. The relay is rated for a maximum load of 2 amps, 240 volts. On units that have been ordered with the alarm option, there will be an alarm set point adjustment on the front of the control. The alarm can be adjusted from 0–10% of the range of the control from the set point, in either direction. If the alarm adjustment is set to the positive side, it will act as a deviation high alarm, if it is set to the negative side, it will act as a deviation low alarm. If it is set at 0, the alarm will energize at the control set point.

## TROUBLESHOOTING

### Common causes of failures are:

- Line wires improperly connected
- Incorrect voltage between line terminals
- No voltage between line terminals
- Connections to terminals are loose, open, or missing
- Short across terminals
- Thermocouple connector “upside down”.  
Red colored lead in negative lead.
- Shorted thermocouple leads
- Thermocouple is open at tip
- Thermocouple lead is broken
- Open or shorted heater circuit
- Open coil in external contactor

- Burned out contactor
- Burned out line fuses
- Defective line switches
- Defective circuit breakers.

If the control still does not function after these points have been checked, it is recommended that the instrument be returned to Tempco for inspection. Do not attempt to repair it yourself, as this often results in costly damage. Make sure to use adequate packing materials to prevent damage during shipment.

## RETURNS

No product returns can be accepted without a completed Return Material Authorization (RMA) form.

## TECHNICAL SUPPORT

Technical questions and troubleshooting help is available from Tempco. When calling or writing please give as much background information on the application or process as possible.

E-mail: [techsupport@tempco.com](mailto:techsupport@tempco.com)

Phone: 630-350-2252  
800-323-6859

**Note:** Information in this manual was deemed correct at the time of printing. The policy of Tempco is one of continuous development and product improvement, and we reserve the right to modify specifications and designs without prior notice. Not responsible for typographical errors.



**TEMPCO** Electric Heater Corporation  
607 N. Central Avenue • Wood Dale, IL 60191-1452 USA  
Tel: 630-350-2252 • Toll Free: 800-323-6859  
Fax: 630-350-0232 • E-mail: [info@tempco.com](mailto:info@tempco.com)  
[www.tempco.com](http://www.tempco.com)