

TEMPCO®

USER MANUAL

TEC-410

High Limit Control

Microprocessor Based Limit Controller



Warning Symbol

This symbol calls attention to an operating procedure, practice, or the like which, if not correctly performed or adhered to, could result in personal injury or damage to or destruction of part or all of the product and system. Do not proceed beyond a warning symbol until the indicated conditions are fully understood and met.

Using the Manual

- Installers Read Chapter 1, 2
- System Designer Read All Chapters
- Expert User Read Page 11

Information in this user's manual is subject to change without notice.

Contents

	Page Number
Chapter 1 Overview	
1-1 General	1
1-2 Ordering Code	1
1-3 Programming Port	2
1-4 Keys and Displays	2
1-5 Menu Overview	6
1-6 Limit Control Operation	7
1-7 Parameter Descriptions	8
Chapter 2 Installation	
2-1 Unpacking	11
2-2 Mounting	11
2-3 Wiring Precautions	11
2-4 Power Wiring	12
2-5 Sensor Installation Guidelines	12
2-6 Thermocouple Input Wiring	12
2-9 Event Input Wiring	13
2-10 Output 1 Wiring	13
2-11 Output 2 Wiring	14
2-12 RS-485	15
2-13 RS-232	15
2-14 Retransmission	15
Chapter 3 Programming	
3-1 Process Input	16
3-2 Limit Control	16
3-3 Set Point Range	18
3-4 PV Shift	17
3-5 Digital Filter	17
3-6 Process Alarms	18
3-7 Limit Annunciator	19
3-8 Signal Conditioner DC Power Supply	19
3-9 PV Retransmission	20
3-10 Data Communication	20
3-11 Remote Reset	21
3-12 Remote Lock	21
3-13 Reference Data	21
Chapter 4 Application	22
Chapter 5 Specifications	23
Chapter 6 Modbus Communications	
6-1 Functions Supported	25
6-2 Exception Responses	26
6-3 Parameter Table	26
6-4 Data Conversion	38
6-5 Communication Examples	29
Appendix	
A-1 Error Codes	30
A-2 Returns	31

NOTE:

It is strongly recommended that a process should incorporate a **LIMIT CONTROL** such as the **TEC-910** which will shut down the equipment at a preset process condition in order to preclude possible damage to products or system.

Informa

Copyright © 2021, Tempco Electric Heater Corporation, all rights reserved. No part of this publication may be reproduced, transmitted, transcribed or stored in a retrieval system, or translated into any language in any form by any means without the written permission of Tempco Electric Heater Corporation.

Figures & Tables

	Page Number
Figure 1.1 Access Overview	2
Figure 1.2 Front Panel Display	3
Figure 1.3 Power Up Sequence	4
Figure 1.4 High Limit Operation	7
Figure 2.1 Mounting Diagram	11
Figure 2.2 Lead Termination	11
Figure 2.3 Rear Terminal Connection Diagram	11
Figure 2.4 Power Supply Connections	12
Figure 2.5 Thermocouple Input Wiring	12
Figure 2.9 Event Input Wiring	13
Figure 2.10 Output 1 Wiring	13
Figure 2.11 Output 2 Wiring	14
Figure 2.12 RS-485 Wiring	15
Figure 2.13 RS-232 Wiring	15
Figure 2.14 Configuration of RS-232 Wiring	15
Figure 2.15 Retransmission Wiring	15
Figure 3.1 Conversion Curve for Linear Type Process Value	16
Figure 3.2 Filter Characteristics	17
Figure 3.3 Normal Process Alarm	18
Figure 3.4 Latching Process Alarm	18
Figure 3.5 DC Power Supply Application	19
Figure 3.6 Remote Reset Application	21
Figure 3.7 Remote Lock Application	21
Figure 4.1 Over Temperature Protection with Remote Reset	22
Table 1.1 DIP Switch Configuration	2
Table 1.2 Display Form of Characters	3
Table 5.1 Input Characteristics	23
Table A.1 Error Codes and Corrective Actions	30

Chapter 1 Overview

1-1 General

The TEC-410 limit control is an over temperature protection or a high limit safety device with a latching output that removes power in an abnormal condition when the process temperature is higher than the high limit set point or lower than the low limit set point.

The unit is powered by 11–26 or 90–250VDC/VAC supply, voltage incorporates a 2 amp form C relay for limit control, a universal input which is fully programmable for thermocouple types J, K, T, E, B, R, S, N, L. An option port is available for one of the following functions: RS-232, RS-485 communication interface and Retransmission. The input signal is digitized by using an 18-bit Analog to Digital converter. Its fast sampling rate (5 times/second) allows the TEC-410 to control fast processes such as pressure and flow in addition to temperature.

RS-485 digital communication is available as an additional option. This option allows the TEC-410 to be integrated with a supervisory control system. An alarm output is another option. A variety of alarm functions and alarm

modes can be programmed for a specific application. The DC power supply output option is used for an external sensor or transmitter. The standard event input option can be programmed for remote reset or remote lock out signal input. The limit annunciator option can be used to control an alarm buzzer.

Three different methods can be used to program the TEC-410.

1. Use the keys on the front panel to program the unit manually
2. Use a PC and setup software to program the unit via the RS-485 port.
3. Use a PC and configuration software to program the unit via the programming port.

High accuracy, maximum flexibility, fast response, and user friendly operation are the main features of the TEC-410 high limit controller.

1-2 Hardware Code

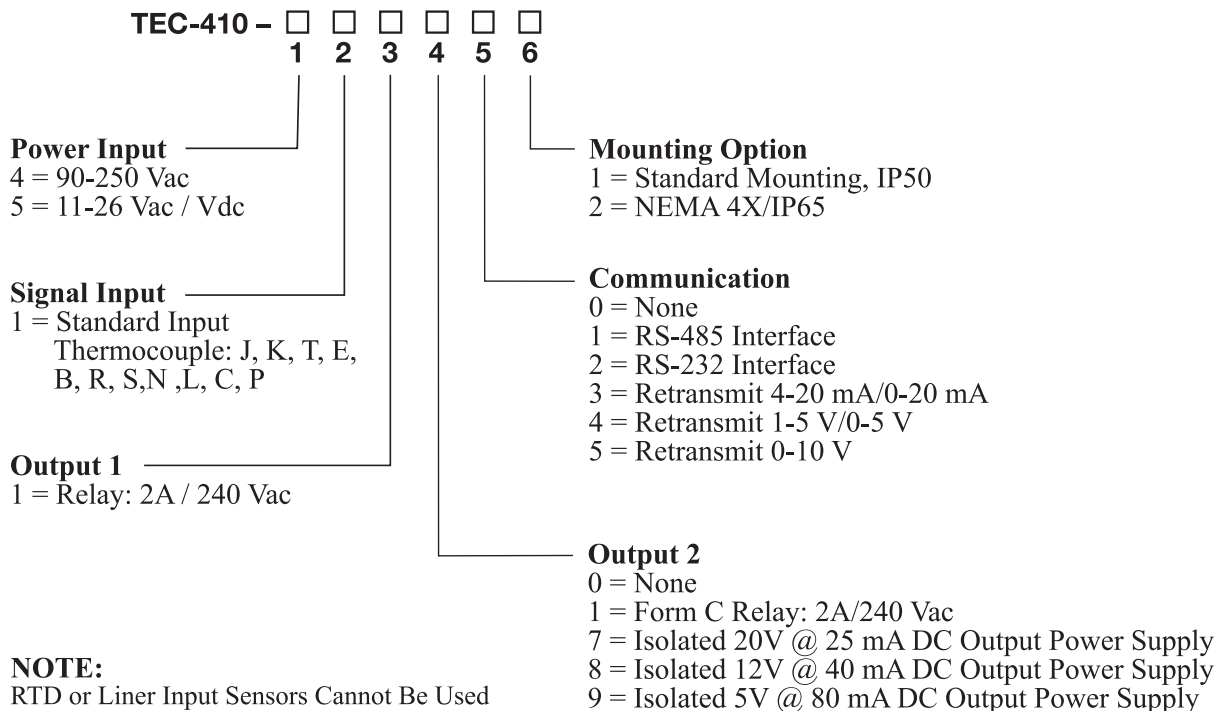

Accessories

TEC99001 = Smart Network Adapter for third party software, converts 255 channels of RS-485 or RS-422 to RS-232 Network

TEC99001 = Smart Network Adapter for programming port to RS-232 interface
TEC99030 = Configuration Software

1-3 Programming Port and DIP Switch

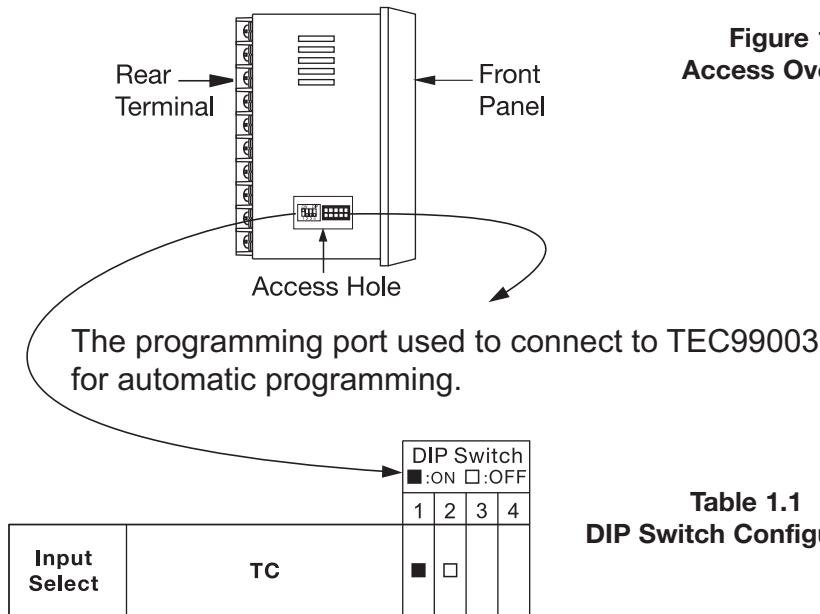

Figure 1.1
Access Overview

The programming port is used for off-line automatic setup and testing procedures only. Don't attempt to make any connection to these pins when the unit is actively being used in a control application.

Table 1.1
DIP Switch Configuration

1-4 Keys and Displays

KEYPAD OPERATION

SCROLL KEY:

1. Select a set point to be displayed.
2. Select a parameter to be viewed or adjusted.
3. Advance display from a parameter code to the next parameter code.

ENTER KEY : 4 seconds, 6 seconds.

Press the enter key for 4 seconds to enter the setup menu.

Press the enter key for 6 seconds to enter the calibration mode.

UP KEY:

This key is used to increase the selected parameter value when the lock indicator is off.

DOWN KEY:

This key is used to decrease the selected parameter value when the lock indicator is off.

RESET KEY:

This key is used to:

1. Revert the limit condition after the process is within the limit.
2. Revert the display to the normal display.
3. Reset the latching alarm, once the alarm condition is removed.
4. Reset the limit annunciator.

Note:

If the RESET key remains pressed, only ONE reset operation will occur. If the unit subsequently goes into a state where reset is required again, the RESET key (or remote reset contacts) must be released (opened) and pressed (closed) again.

UNLOCK KEY  Press the RESET key for 4 seconds to enable up/down key function, and the lock indicator will be extinguished. However, this function is disabled when the EI input pins are closed and remote lock is selected for EIFN (Event Input Function). See section 3-11

The reference data are reset as long as the reset key is pressed for 4 seconds. See section 3-13.

Figure 1.2
Front Panel Display

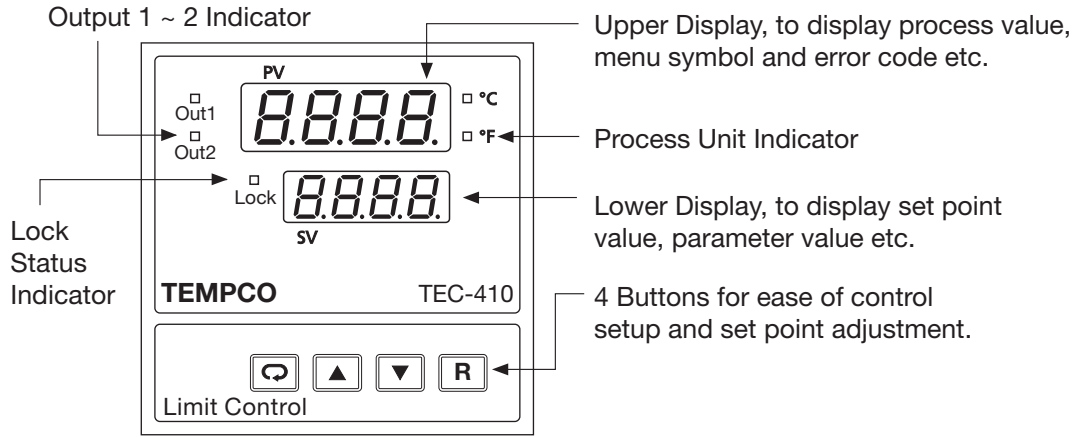

Table 1.2
Display Form of Characters

A	<i>A</i>	E	<i>E</i>	I	<i>I</i>	N	<i>n</i>	S	<i>S</i>	X	
B	<i>b</i>	F	<i>F</i>	J	<i>J</i>	O	<i>o</i>	T	<i>t</i>	Y	<i>y</i>
C	<i>C</i>	G	<i>G</i>	K	<i>K</i>	P	<i>P</i>	U	<i>u</i>	Z	
c	<i>c</i>	H	<i>H</i>	L	<i>L</i>	Q		V	<i>v</i>	?	<i>?</i>
D	<i>d</i>	h	<i>h</i>	M	<i>m</i>	R	<i>r</i>	W		=	<i>=</i>

▣: Indicates Abstract Characters

How to display a 5-digit number:

For a number with a decimal point, the display will be shifted one digit to the right:
-199.99 will be displayed as -199,9, 4553.6 will be displayed as 4553

For a number without a decimal point, the display will be divided into two alternating phases:

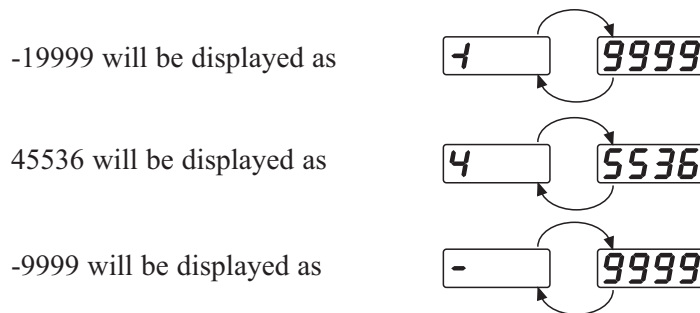

NORMAL DISPLAY

During normal operation, the unit will display the process value and the word SAFE.

ABNORMAL DISPLAY

Whenever the process is outside the normal range, the lower display will display the limit set point value, instead of displaying the word SAFE.

SENSOR BREAK DISPLAY

If a break is detected in the sensor circuit, the display will show:

SEnb

A-D FAILURE DISPLAY

If failure is detected in the A-D converter circuit, the display will show:

Ad.Er

* WARNING *

Sensor failure will not be detected during Low-Limit Operation.

* WARNING *

Sensor failure will not be detected unless using thermocouple inputs.

POWER UP SEQUENCE

Figure 1.3
Power Up Sequence

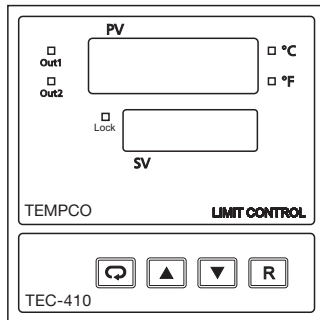

All segments of display and indicators are left off for 0.5 second.

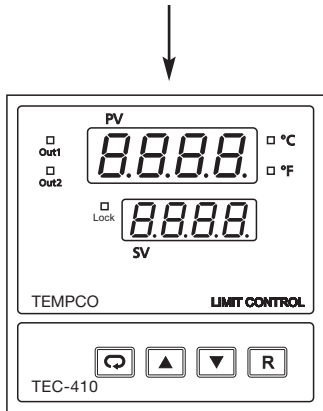

All segments of display and indicators are lit for 1.5 second.

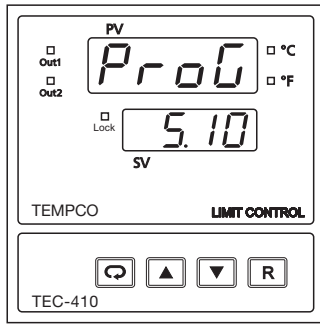

Display program code of the product for 1.5 seconds.
The example shows program no.5 with version 10.

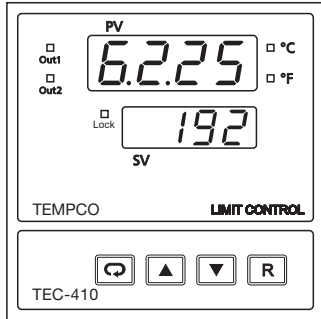

Display Date Code for 1.5 seconds. The example shows Year 2006 (6), Month February (2), Date 25th. This means that the product is produced on February 25th, 2006. Note that the month code A is for October, B is for November and C is for December.

Display the serial number (001-999) for 1.5 seconds.

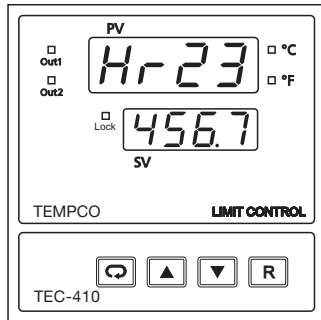

Display the hours used for 1.5 seconds. The example shows that the unit has been used for 23456.7 hours since production.

Verify that all electrical connections have been made properly before applying power to the unit.

During power up, a self-test procedure will be performed within 6.5 seconds. During the self-test period all outputs are left off. When the self-test procedure is complete, the unit will revert to normal operation.

1-5 Menu Overview

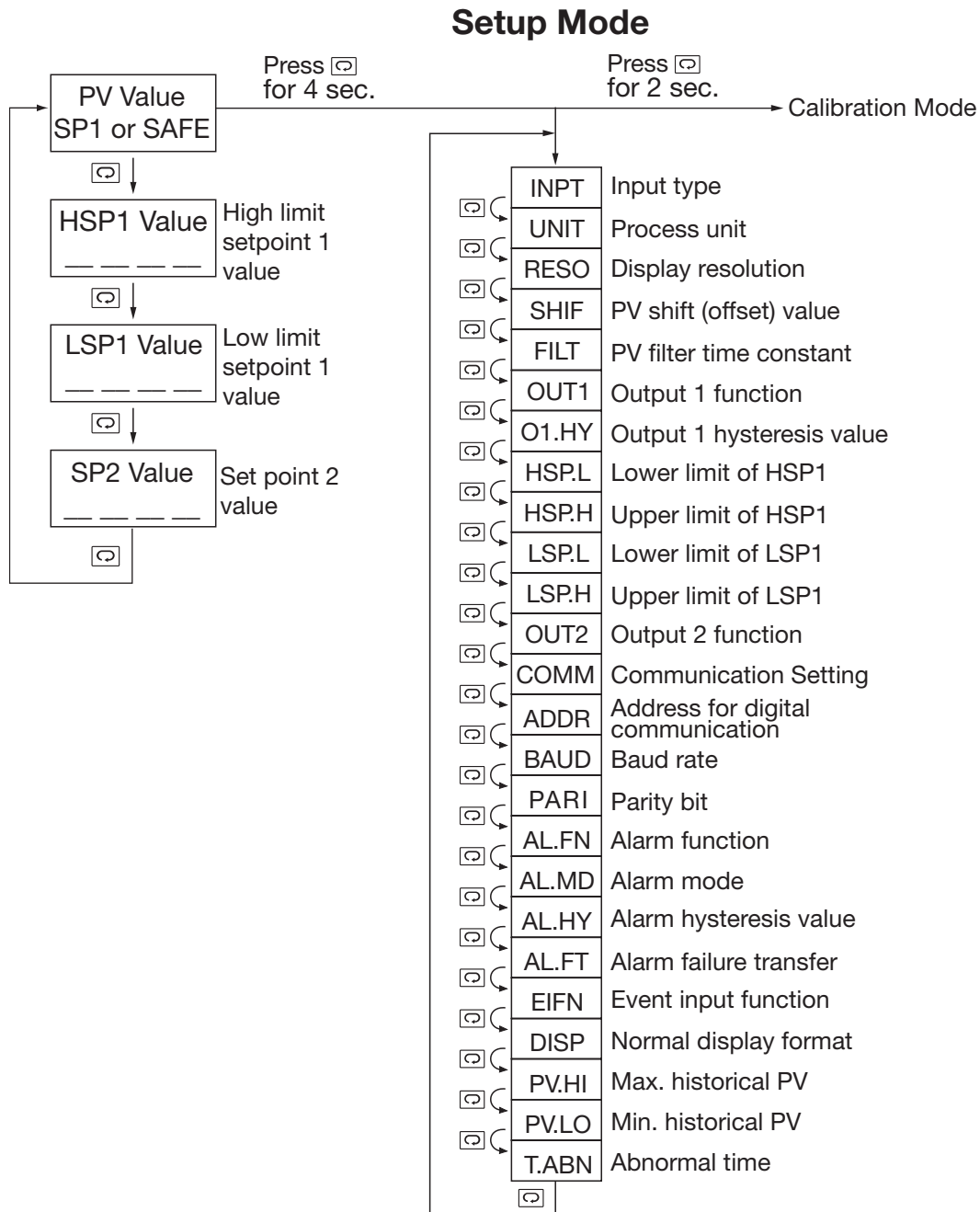

Note 1. The flow charts show a complete listing of parameters. For the actual application, the number of available parameters are dependent on the setup conditions, and should be less than that shown in the flow charts.

Note 2. Press **R** key for 4 seconds to enable up/down key function and extinguish the LOCK indicator.

1-6 Limit Control Operation

HIGH LIMIT OPERATION

If Hi. is selected for OUT1, the unit will perform high limit control. When power is applied the OUT1 relay is de-energized. After the 6.5 second self-test period, if the process is below the high limit set point (HSP1) the output 1 relay will be energized and the OP1 indicator will go off. If the process goes above the high limit set point, the relay will be de-energized, the OP1 indicator will go on, and the display will show the process value. After the process falls below the high limit set point and the RESET key is pressed or the remote reset input is applied, the relay will be energized and the OP1 indicator will go off.

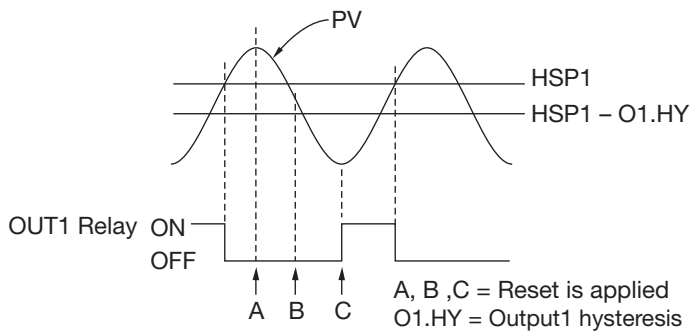
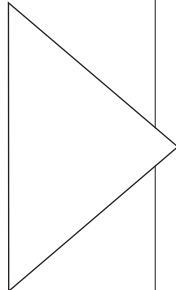

Figure 1.4
High Limit Operation

1-7 Parameter Descriptions

Parameter Notation	Parameter Description (Refer to Page:)	Range	Default Value
<i>HSP1</i> HSP1	High Limit Set point 1	Low: HSP.L High: HSP.H	100.0°C (212.0°F)
<i>LSP1</i> LSP1	Low Limit Set point 1	Low: LSP.L High: LSP.H	0.0°C (32.0°F)
<i>SP2</i> SP2	Set point 2 Value for Output 2	Low: -19999 High: 45536	90.0°C (194.0°F)
<i>inPE</i> INPT	Input sensor selection (Page 11, 17 & 25)	0) <i>J.t.C</i> : J type thermocouple 1) <i>K.t.C</i> : K type thermocouple 2) <i>T.t.C</i> : T type thermocouple 3) <i>E.t.C</i> : E type thermocouple 4) <i>B.t.C</i> : B type thermocouple 5) <i>R.t.C</i> : R type thermocouple 6) <i>S.t.C</i> : S type thermocouple 7) <i>N.t.C</i> : N type thermocouple 8) <i>L.t.C</i> : L type thermocouple 9) <i>C.t.C</i> : C type thermocouple 10) <i>P.t.C</i> : P type thermocouple 11) <i>Pt100</i> : PT 100 ohms DIN curve 12) <i>Pt100</i> : PT 100 ohms JIS curve 13) <i>4-20</i> : 4-20 mA linear current input 14) <i>0-20</i> : 0-20 mA linear current input 15) <i>0-60</i> : 0-60 mV linear millivolt input 16) <i>0-1V</i> : 0-1V linear voltage input 17) <i>0-5V</i> : 0-5V linear voltage input 18) <i>1-5V</i> : 1-5V linear voltage input 19) <i>0-10V</i> : 0-10V linear voltage input	1 (0)
<i>unit</i> UNIT	Process unit	0) <i>C</i> : Degree C unit 1) <i>F</i> : Degree F unit 2) <i>Pu</i> : Process unit	0 (1)
<i>reso</i> RESO	Display Resolution	0) <i>no.dp</i> : No decimal point 1) <i>1-dp</i> : 1 decimal digit 2) <i>2-dp</i> : 2 decimal digits 3) <i>3-dp</i> : 3 decimal digits	1
* <i>inLo</i> INLO	Low scale value for linear Input (Page 11)	Low: -19999 High: IN.HI	0
* <i>inHi</i> INHI	High scale value for linear Input (Page 11)	Low: IN.LO High: 45536	100.0
<i>SPiF</i> SPIF	PV Shift (offset) Value (Page 18)	Low: -200.0°C (-360.0°F) High: 200.0°C (360.0°F)	0.0
<i>Filt</i> FILT	PV Filter Time Constant (Page 18)	0) <i>0</i> : 0 second time constant 1) <i>0.2</i> : 0.2 second time constant 2) <i>0.5</i> : 0.5 second time constant 3) <i>1</i> : 1 second time constant 4) <i>2</i> : 2 seconds time constant 5) <i>5</i> : 5 seconds time constant 6) <i>10</i> : 10 seconds time constant 7) <i>20</i> : 20 seconds time constant 8) <i>30</i> : 30 seconds time constant 9) <i>60</i> : 60 seconds time constant	2
<i>out1</i> OUT1	Output 1 Function	2) <i>Hi</i> : High limit control 3) <i>Lo</i> : Low limit control 4) <i>HiLo</i> : High/Low limit control	2



*** WARNING ***
DO NOT USE THESE
INPUT SETTINGS

*** WARNING ***
Sensor failure will not be
detected during Low-Limit
Operation.

*** Not Present for Thermocouple Input**

Parameter Notation	Parameter Description (Refer to Page:)	Range	Default Value
<i>o1.HY</i> O1.HY	Output 1 Hysteresis Value	Low: 0.1 High: 10.0°C (18.0°F)	0.2
<i>HSP.L</i> HSP.L	Lower Limit of HSP1 (Page 18)	Low: -19999 High: HSP.H	(32.0°F)
<i>HSP.H</i> HSP.H	Upper Limit of HSP1 (Page 18)	Low: HSP.L High: 45536	(1832.0°F)
<i>LSP.L</i> LSP.L	Lower Limit of LSP1	Low: -19999 High: LSP.H	-100.0°C (-148.0°F)
<i>LSP.H</i> LSP.H	Upper Limit of LSP1	Low: :LSP.L High: 45536	0.0°C (32.0°F)
<i>OUT2</i> OUT2	Output 2 Function	0) <i>nonE</i> : No Function 1) <i>dEPS</i> : DC power supply output 2) <i>ALn</i> : Alarm Output 3) <i>L.Rn</i> : Limit Annunciator	2
<i>COMM</i> COMM	Communication function (Page 23)	0) <i>nonE</i> : No communication 1) <i>rtu</i> : Modbus RTU mode protocol 2) <i>4-20</i> : 4-20 mA DC transmission output 3) <i>0-20</i> : 0 - 20 mA DC transmission output 4) <i>0-5V</i> : 0 - 1V DC transmission output 5) <i>1-5V</i> : 0 - 5V DC transmission output 6) <i>0-10</i> : 1 - 5V DC transmission output	1
<i>ADDR</i> ADDR	Address Assignment of Digital COMM	Low: 1 High: 255	—
<i>BAUD</i> BAUD	Baud rate of digital communication (Page 25)	0) <i>0.3</i> : 0.3 Kbits/s baud rate 1) <i>0.6</i> : 0.6 Kbits/s baud rate 2) <i>1.2</i> : 1.2 Kbits/s baud rate 3) <i>2.4</i> : 2.4 Kbits/s baud rate 4) <i>4.8</i> : 4.8 Kbits/s baud rate 5) <i>9.6</i> : 9.6 Kbits/s baud rate 6) <i>14.4</i> : 14.4 Kbits/s baud rate 7) <i>19.2</i> : 19.2 Kbits/s baud rate 8) <i>28.8</i> : 28.8 Kbits/s baud rate 9) <i>38.4</i> : 38.4 Kbits/s baud rate	5
<i>PARI</i> PARI	Parity bit of digital communication	0) <i>Even</i> : 8 bit even parity 1) <i>odd</i> : 8 bit odd parity 2) <i>nonE</i> : 8 bit none parity	0
<i>AOFN</i> AOFN	Analog/Retransmission Output Function	0) <i>PV</i> : Process Value 1) <i>HSP1</i> : High Limit Set point 1 2) <i>LSP1</i> : Low Limit Set point 1	—



Parameter Notation	Parameter Description (Refer to Page:)	Range	Default Value
<i>AL.Fn</i> AL.FN	Alarm Function (Page 19)	6) <i>P.V.H.A</i> : Process value high alarm 7) <i>P.V.L.A</i> : Process value low alarm	6
<i>AL.MD</i> AL.MD	Alarm mode	6) <i>non</i> : Normal alarm action 7) <i>Ltch</i> : Latching alarm action	0
<i>AL.HY</i> AL.HY	Alarm hysteresis value	Low: 0.1 High: 10°C (18°F)	0.2
<i>AL.Ft</i> AL.FT	Alarm failure transfer	0) <i>off</i> : Alarm Output goes off as unit fails 1) <i>on</i> : Alarm Output goes on as unit fails	1
<i>EIFn</i> EIFN	Event input function (Page 22)	0) <i>nonE</i> : No event function 1) <i>resE</i> : Remote reset for output 1, output 1 on 2) <i>lock</i> : Remote lock for the unit	0
<i>DISP</i> DISP	Normal display format	0) <i>SAFE</i> : Display SAFE 1) <i>HSP1</i> : Display the value of HSP1 2) <i>LSP1</i> : Display the value of LSP1	0
<i>PV.Hi</i> PV.HI	Historical Max. value of PV (Page 23)	Low: -19999 High: 45536	—
<i>PV.Lo</i> PV.LO	Historical Min. value of PV (Page 25)	Low: -19999 High: 45536	—
<i>T.ABn</i> T.ABN	Accumulated Time during abnormal condition	Low: 0 High: 6553.5 minutes	—

Chapter 2 Installation

⚠ Dangerous voltages capable of causing death are sometimes present in this instrument. Before installation or beginning any troubleshooting procedures, the power to all equipment must be switched off and isolated. Units suspected of being faulty must be disconnected and removed to a properly equipped workshop for testing and repair. Component replacement and internal adjustments must be made by a qualified maintenance person only.

⚠ To minimize the possibility of fire or shock hazards do not expose this instrument to rain or excessive moisture.

⚠ Do not use this instrument in areas under hazardous conditions such as excessive shock, vibration, dirt, moisture, corrosive gases or oil. The ambient temperature of the area should not exceed the maximum rating specified in chapter 6.

2-3 Wiring Precautions

- Before wiring, verify the correct model number and options on the label. Switch off the power while checking.
- Care must be taken to ensure that the maximum voltage rating specified on the label is not exceeded.
- It is recommended that the power for these units be protected by fuses or circuit breakers rated at the minimum value possible.
- All units should be installed in a suitable enclosure to prevent live parts from being accessible to human hands and metal tools. Metal enclosures and/or subpanels should be grounded in accordance with national and local codes.
- All wiring must conform to appropriate standards of good practice and local codes and regulations. Wiring must be suitable for the voltage, current, and temperature rating of the system.
- Beware not to over-tighten the terminal screws. The torque should not exceed 1 N-m (8.9 lb-in or 10 KgF-cm).
- Unused control terminals should not be used as jumper points as they may be internally connected, causing damage to the unit.
- Verify that the ratings of the output devices and the inputs as specified are not exceeded.
- Electrical power in industrial environments contains a certain amount of noise in the form of transient voltage and spikes. This electrical noise can adversely affect the operation of microprocessor-based controls. For this reason the use of shielded thermocouple extension wire which connects the sensor to the controller is strongly recommended. This wire is a twisted-pair construction with foil wrap and drain wire. The drain wire is to be attached to ground in the control panel only.

2-1 Unpacking

Upon receipt of the shipment, remove the unit from the carton and inspect the unit for any shipping damage.

If there is any damage due to transit, report it and file a claim with the carrier. Write down the model number, serial number and date code. for future reference when corresponding with our Service Department. The serial number (SN) and date code (D/C) are labeled on the box and the housing of the unit.

2-2 Mounting

Make the panel cutout according to the dimensions shown in figure 2.1.

Remove the mounting clamps and screws and insert the controller into the panel cutout. Reinstall the mounting clamp and screws. Gently tighten the screws until the front panel fits snugly in the cutout.

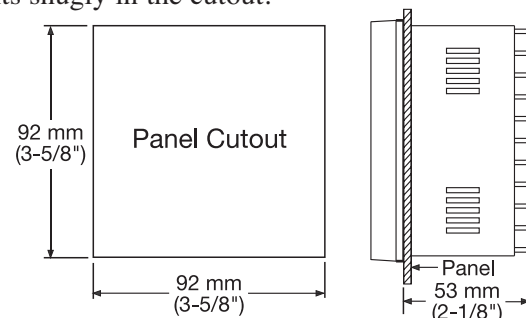
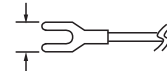

Figure 2.1 Mounting Diagram

9/32" max. (7.0 mm)



Spade Connector for #6 Stud

Figure 2.2 Lead Termination

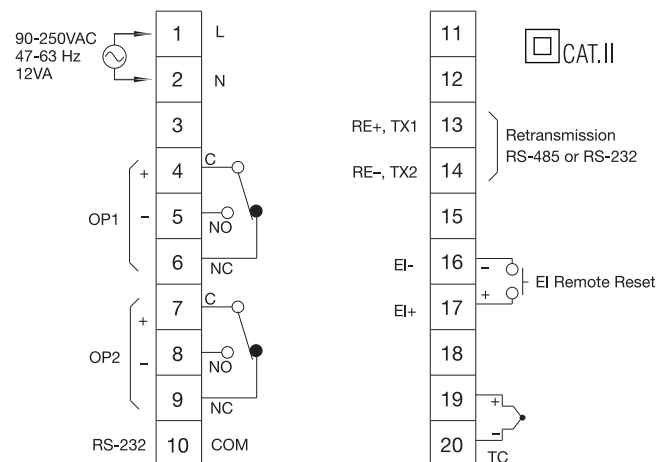

Notes: 50°C max. air ambient
ASTM thermocouples (USA), the red colored lead is negative.

Figure 2.3 Rear Termination Connection Diagram

2-4 Power Wiring

The controller is designed to operate at 11–26VAC/VDC to 90–250VAC. Check that the installation voltage corresponds to the power rating indicated on the product label before connecting power to the controller. Near the controller a fuse and a switch rated at 2A/250VAC should be equipped as shown in Figure 2-4.



This equipment is designed for installation in an enclosure which provides adequate protection against electric shock. The enclosure must be connected to earth ground.

Local requirements regarding electrical installation should be rigidly observed. Consideration should be given to prevent unauthorized personnel from accessing the power terminals.

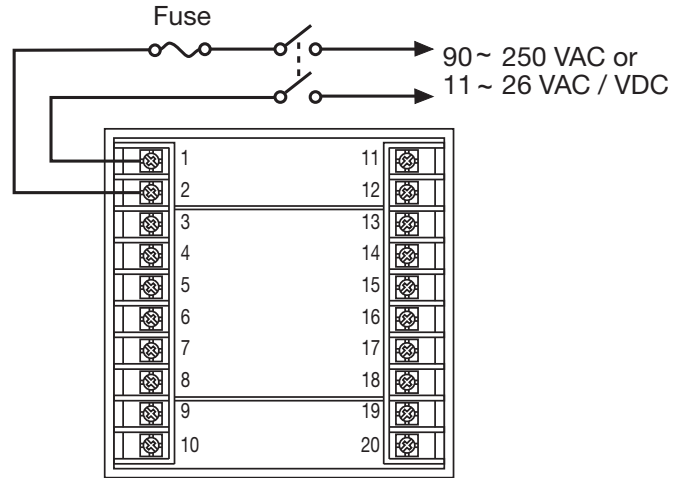

Figure 2.4
Power Supply Connections

2-5 Sensor Installation Guidelines

Proper sensor installation can eliminate many problems in a control system. The probe should be placed so that it can detect any temperature change with minimal thermal lag. In a process that requires fairly constant heat output, the probe should be placed close to the heater. In a process where the heat demand is variable, the probe should be close to the work area. Some experimentation with probe location is often required to find the optimum position.

In a liquid process, the addition of agitation will help to eliminate thermal lag. Since the thermocouple is basically a point measuring device, placing more than one thermocouple in parallel will provide an average temperature readout and produce better results in most air heated processes.

Proper sensor type is also a very important factor in obtaining precise measurements. The sensor must have the correct temperature range to meet the process requirements. In special processes, the sensor might have requirements such as leak-proof, anti-vibration, antiseptic, etc.

Standard sensor limits of error are $\pm 4^{\circ}\text{F}$ ($\pm 2^{\circ}\text{C}$) or 0.75% of the sensed temperature (half that for special limits of error) plus drift caused by improper protection or an over-temperature occurrence. This error is far greater than controller error and cannot be corrected on the sensor except by proper selection and replacement.

2-6 Thermocouple Input Wiring

Thermocouple input connections are shown in figure 2-5. The correct type of thermocouple extension lead-wire or compensating cable must be used for the entire distance between the unit and the thermocouple, ensuring that the correct polarity is observed throughout. Junction/terminal blocks or splices in the cable run should be avoided, if possible.

If the length of the thermocouple plus the extension wire is too long, it may affect the temperature measurement. A 400 ohms K type or a 500 ohms J type thermocouple lead resistance will produce approximately 1°C temperature error.

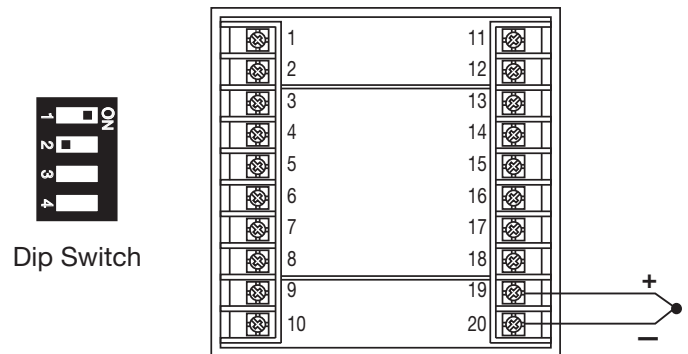

Figure 2.5
Thermocouple Input Wiring

2-9 Event Input Wiring

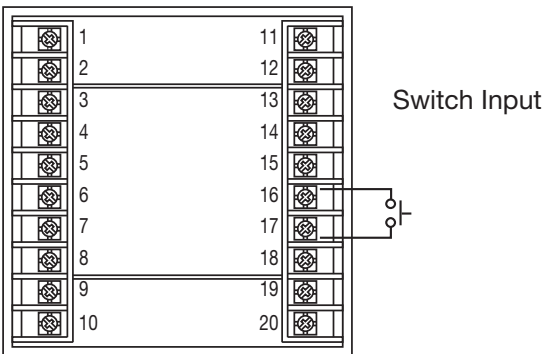
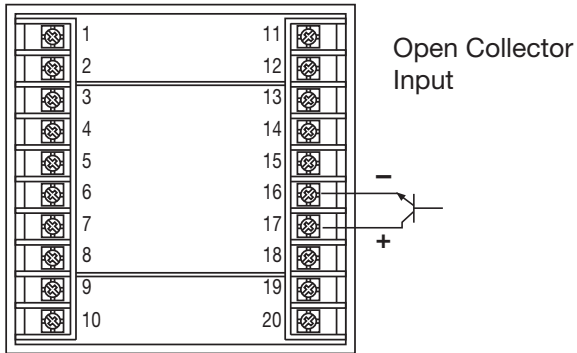

Figure 2.9
Event Input Wiring

The event input can accept a switch signal as well as an open collector signal. The event input function (EIFN) is activated as the switch is closed or an open collector (or a logic signal) is pulled down.

2-10 Output 1 Wiring

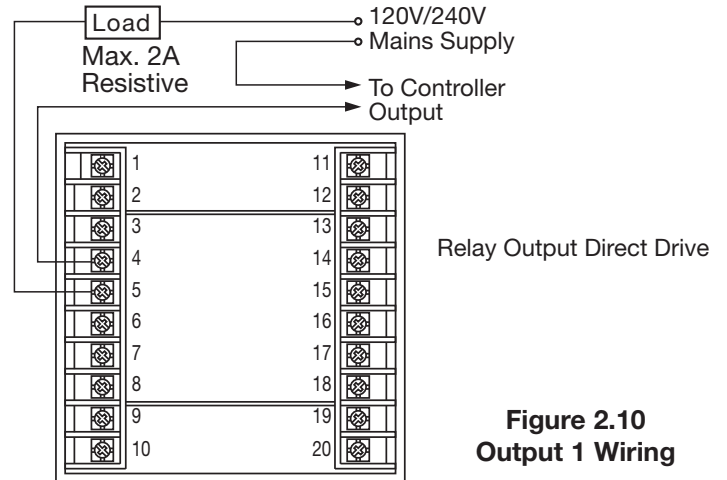
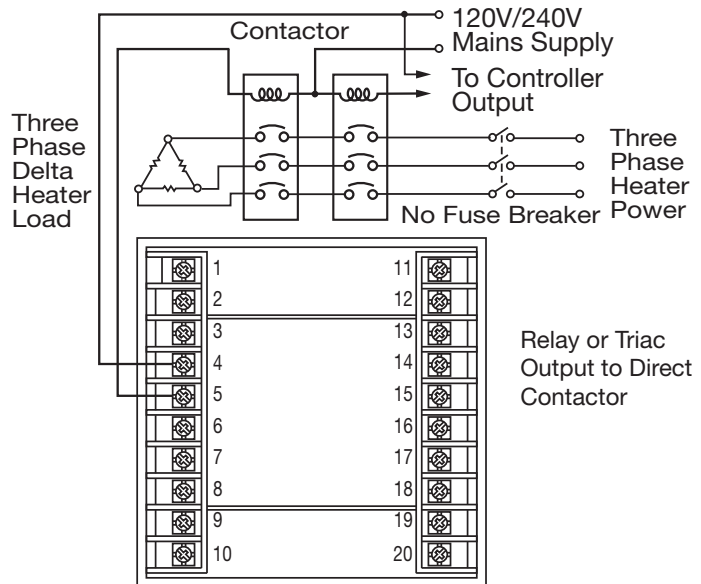

Figure 2.10
Output 1 Wiring



2-11 Output 2 Wiring

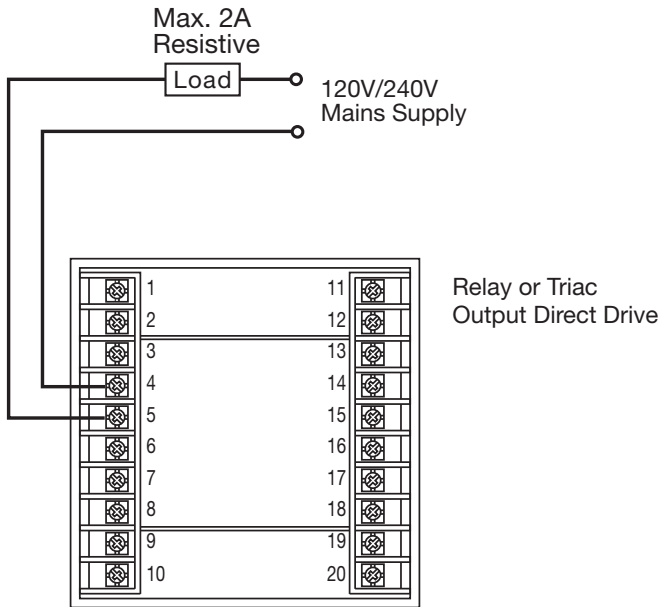
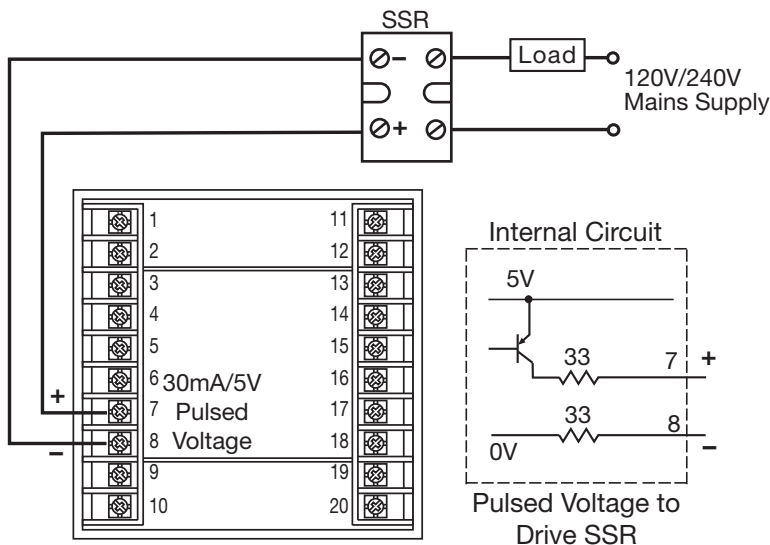
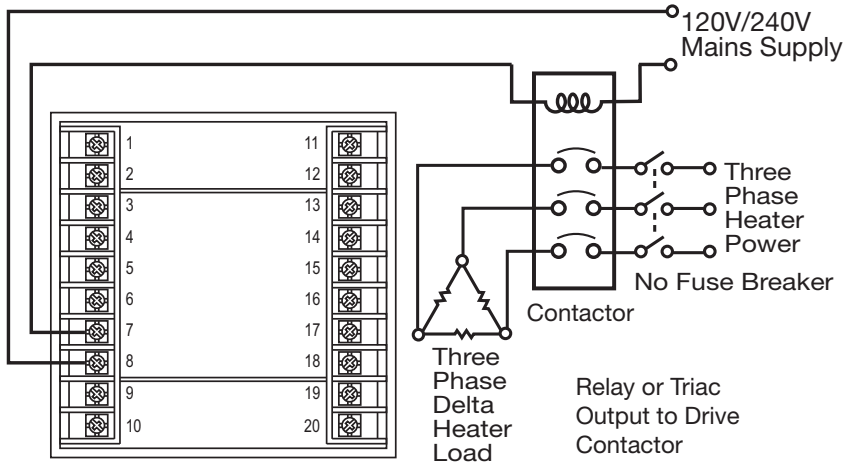

Figure 2.11
Output 2 Wiring



2-12 RS-485

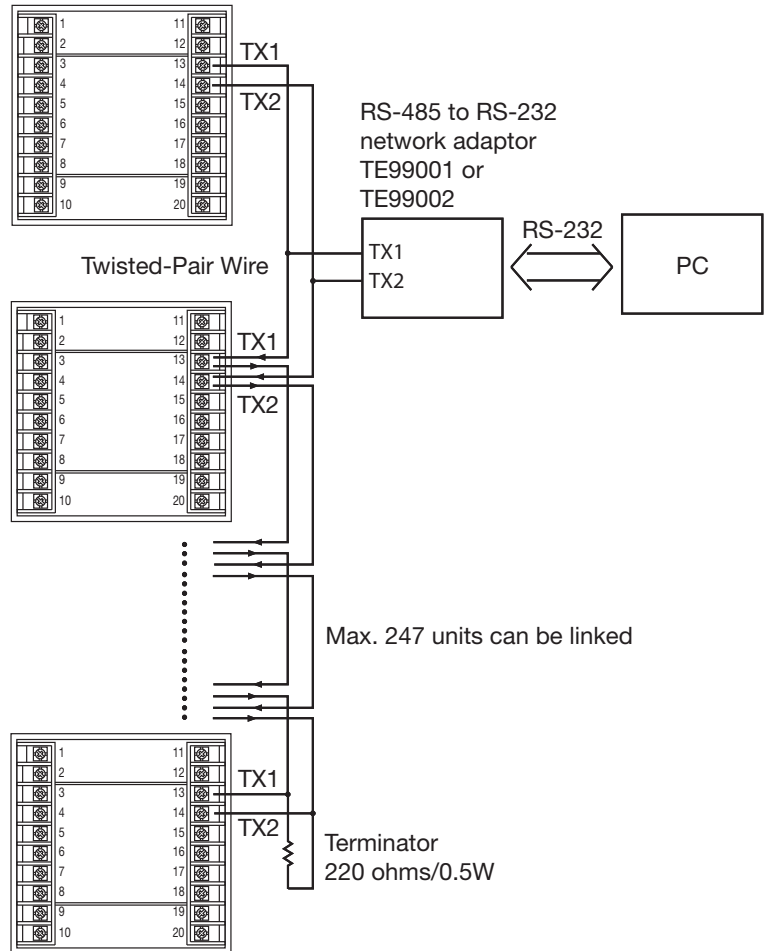

Figure 2.12
RS-485 Wiring

2-13 RS-232

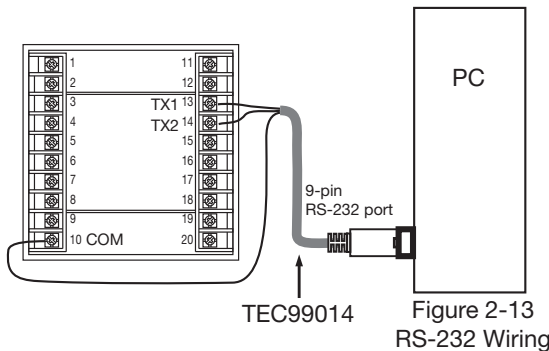

Figure 2.13
RS-232 Wiring

If you use a conventional 9-pin RS-232 cable instead of TEC99014, the cable must be modified according to the following circuit diagram.

Figure 2.13 RS-232 Wiring

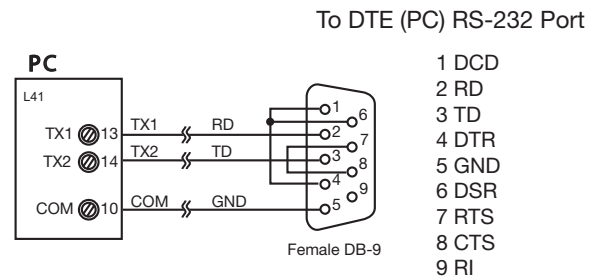

Figure 2.14
Configuration of RS-232 Wiring

2-14 Retransmission

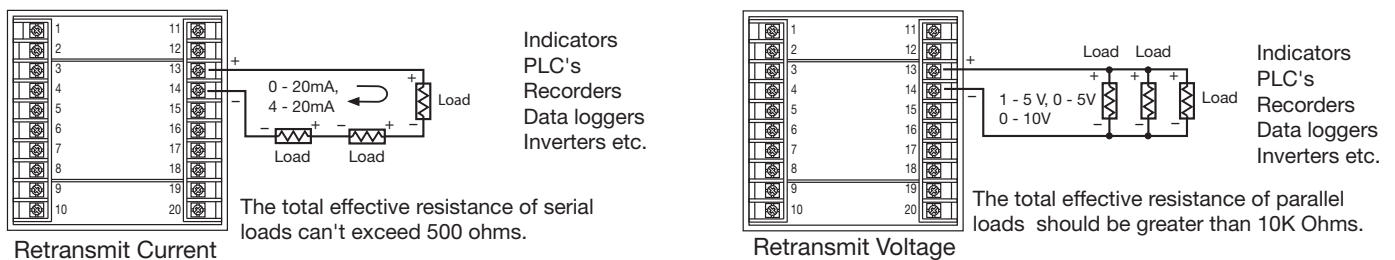



Figure 2.15 Retransmission Wiring

3-1 Process Input

Press  for 4 seconds and release to enter the setup menu. Press  to select parameter. The display will indicate the parameter symbol and the value (or selection) for that parameter.

INPT: Selects the Thermocouple sensor type for the process input.

UNIT: Selects the process unit

RESO: Selects the location of the decimal point (Resolution) for most (not all) process related parameters.

* WARNING *

Sensor failure will not be detected during Low-Limit Operation.

3-2 Limit Control

OUT1: Selects the output 1 function. The available output 1 functions are: High Limit Control, Low Limit Control. Refer to section 1-6 on page 7 for limit control operation.

O1.HY: Output 1 hysteresis value. The hysteresis value is adjusted to a value to eliminate relay jitter in a noisy environment.

3-3 Set Point Range

HSP.L : Lower limit of HSP1. Hidden if LO is selected for OUT1

HSP.H : Upper limit of HSP1. Hidden if LO is selected for OUT1

HSP.L and HSP.H in the setup menu are used limit the adjustment range of HSP1.

3-4 PV Shift

In certain applications it is desirable to shift the controller display value (PV) from its actual value. This can be easily accomplished with this control by using the PV shift function.

Cycle the unit to the SHIF parameter by using the scroll key in setup menu. The number you adjust, either positive or negative, will be added to the actual value. The SHIF function will alter the process variable (PV) only.

SHIF: PV shift (offset) value

Output Functionality

Output 2 can be setup for the following functions, OUT2:

DC power supply output, dCPS

Alarm Output. ALm

Limit Annunciator, L_AN

3-5 Digital Filter

In certain applications the process value is too unstable to be read. To improve this, a programmable low pass filter is incorporated in the TEC-410. This is a first order filter with the time constant specified by the FILT parameter which is found in the setup menu. The default value of SHIF is set at 0.5 seconds before the unit is shipped. Adjust FILT to change the time constant from 0 to 60 seconds. 0 seconds means no filter is applied to the input signal. The filter is characterized by Figure 3-2 below.

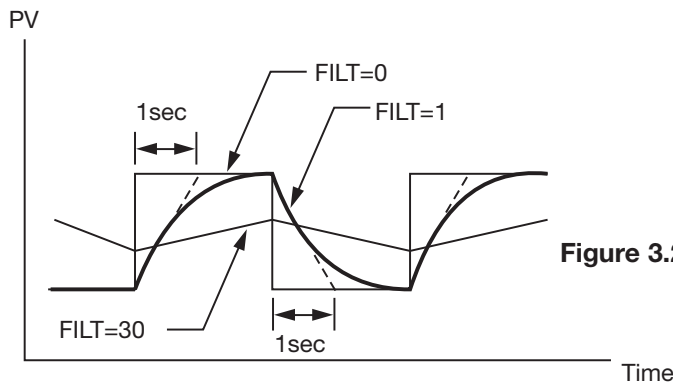

Figure 3.2 Filter Characteristics

3-6 Process Alarms

If Output 2 is designated as an “Alarm Output”, the alarm function, AL.FN can be setup for Process Value High Alarm, PV.H.A or Process Value Low Alarm, PV.L.A. The process alarm sets an absolute trigger level. When the process exceeds that absolute trigger level, an alarm occurs. The trigger level is determined by the setting of the set point 2 value SP2 and the alarm hysteresis value AL.HY. The hysteresis value is introduced to avoid interference in a noisy environment. Normally, AL.HY can be set with a minimum value 0.1.

The trigger levels for the process high alarm are SP2 and SP2-AL.HY.
 The trigger levels for the process low alarm are SP2+AL.HY and SP2.

There are two types of alarm mode, AL.MD that can be selected.
 They are Normal Alarm (NORM) and Latching Alarm (LATCH).

Normal Alarm: AL.MD=NORM

When the normal alarm is selected, the alarm output is de-energized in the non-alarm condition and energized in an alarm condition.

Latching Alarm: AL.MD=LATCH

If the latching alarm is selected, once the alarm output is energized, it will remain unchanged even if the alarm condition has been cleared, unless the power is shut off or the RESET key (or remote reset button) is pressed.

Failure Transfer: AL.FT=OFF or ON

If a **Sensor Break** or an **A-D Failure** occurs, the alarm output will be on or off according to the setting of AL.FT.

Examples:

SP2=200 AL.HY=10.0 AL.MD=NORM AL.FN=P.V.H.A

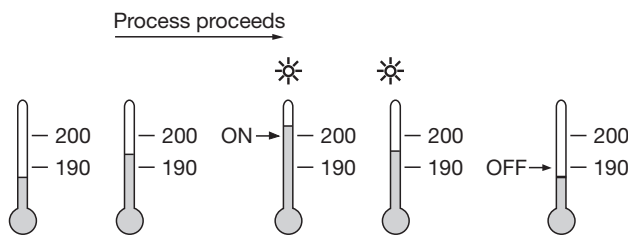

Figure 3.3 Normal Process Alarm

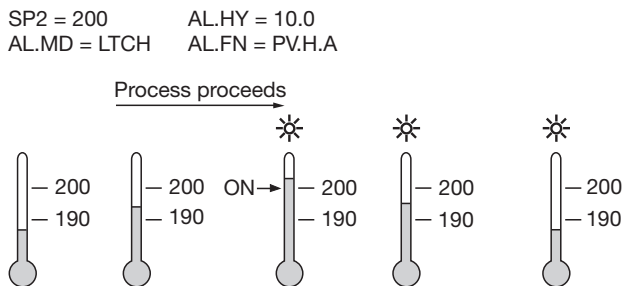

Figure 3.4 Latching Process Alarm

3-7 Limit Annunciator

If Output 2 is designated as an Limit Annunciator, (L_AN) the output relay will track the Limit setpoint. If the limit setpoint is or has been reached by the process value, then the limit annunciator will be energized and the OP2 indicator LED will be lit and remain unchanged until the reset key or remote reset input is applied.

3-8 Signal Conditioner DC Power Supply

Three types of isolated DC power supplies are available to supply an external transmitter or sensor. These are 20V rated at 25mA, 12V rated at 40mA, and 5V rated at 80mA. DC voltage is delivered to the output 2 terminals by selecting DCPS for OUT2 in the setup menu.

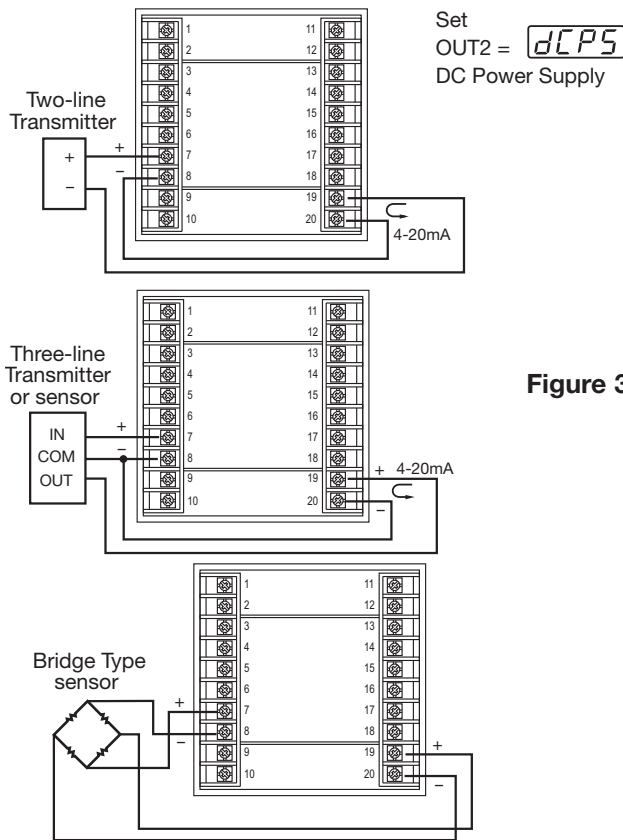

Figure 3.5 DC Power Supply Application

Caution:

To avoid damage, don't use the DC power supply beyond its rating current. Purchase a power supply with the correct voltage to suit your external devices. See ordering code in section 1-2.

3-9 PV Retransmission

The controller can output (retransmit) the process value via its retransmission terminals RE+ and RE- provided that the retransmission option is ordered. A correct signal type should be selected for COMM parameter to meet the retransmission option installed. AOLO and AOHI are adjusted to specify the low scale and high scale values of retransmission.

3-10 Data Communication

The controller support RTU mode of Modbus protocol for data communication. Other protocols are not available for the TEC-410.

Two types of interface are available for data communication. These are RS-485 and RS-232 interface. Since RS-485 uses a differential architecture to drive and sense signal instead of a single-ended architecture like the one used for RS-232, RS-485 is less sensitive to noise and suitable for communication over a longer distance. RS-485 can communicate without error over a 1km distance while RS-232 is not recommended for a distance of over 60 feet (20 meters).

Using a PC for data communication is the most economical method. The signal is transmitted and received through the PC communication port (generally RS-232). Since a standard PC can't support an RS-485 port, a network adapter (such as TEC99001) has to be used to convert RS-485 to RS-232 for a PC if RS-485 is required for data communication. Up to 247 RS-485 units can be connected to one RS-232 port; therefore a PC with four comm ports can communicate with 988 units.

Setup

Enter the setup menu. Select RTU for COMM. Set individual addresses for any units that are connected to the same port. Set the baud rate (BAUD), data bit (DATA), parity bit (PARI) and stop bit (STOP) so that these values are accordant with PC setup conditions.

If you use a conventional 9-pin RS-232 cable instead of TEC99014, the cable should be modified for proper operation of RS-232 communication according to section 2-9.

Refer to Chapter 6 for a complete technical description of the Modbus Communications Protocol.

3-11 Remote Reset

If REST is selected for the Event Input Function EIFN, terminals 16 and 17 will act as remote reset input. Pressing the remote reset button will perform the same function as pressing the RESET key. Refer to section 1-4 for RESET key function.

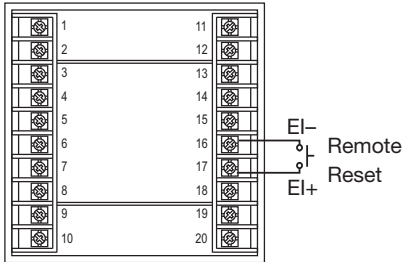

Figure 3.6 Remote Reset Application

3-12 Remote Lock

If LOCK is selected for Event Input Function EIFN, terminals 16 and 17 will act as remote lock input. Turning the remote lock switch on will keep all the parameter settings from being changed. If the switch is opened the lock indicator is extinguished and the up/down key is enabled.

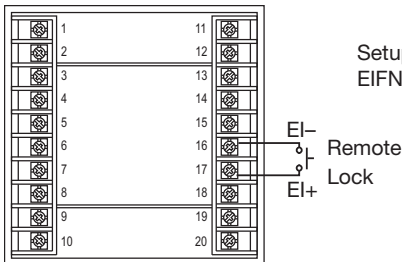

Figure 3.7 Remote Lock Application

3-13 Reference Data

There are three reference data points stored by the control and accessed in the setup menu. The reference data are read-only data. The maximum historical PV, displayed by *PV.HI*, which shows the maximum process value since the last UNLOCK operation. The minimum historical PV, displayed by *PV.LO*, shows the minimum process value since the last UNLOCK operation. The abnormal time, displayed by *T.ABN*, which shows the total accumulated time (minutes) during the process which has been in abnormal condition since the last UNLOCK operation.

The values of the reference data will be initiated as soon as the RESET key is pressed for 4 seconds (UNLOCK operation). After the UNLOCK operation, the PV.HI and PV.LO values will start from the current process value and T.ABN value will start from zero.

Chapter 4 Application

An oven uses a single phase heater to heat the process. A single loop temperature control TEC-9100 is used to regulate the temperature. A TEC-410 limit control is used to protect the process from being overheated. The wiring diagram is shown below.

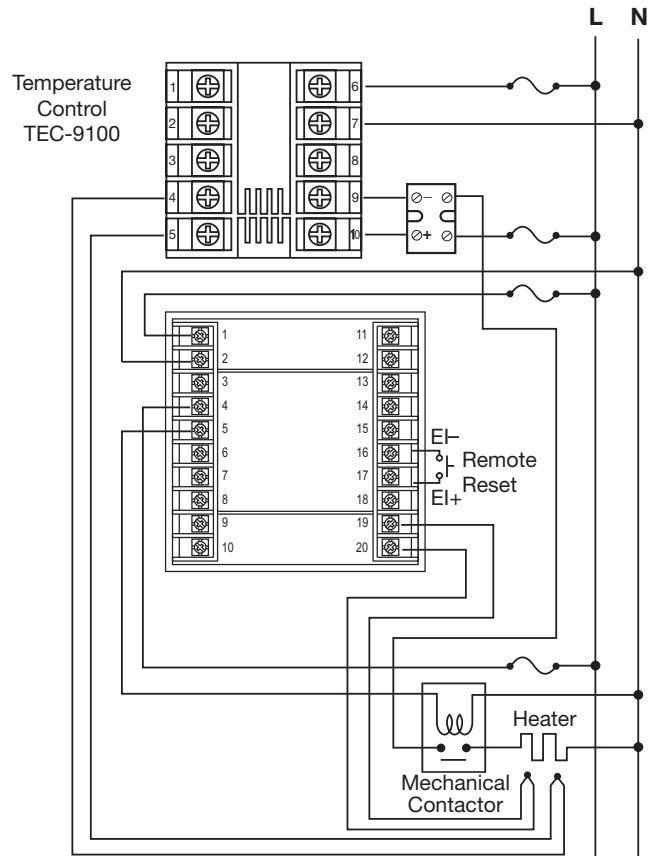

Figure 4.1 Over-Temperature Protection with Remote Reset

Chapter 5 Specifications

Power

90–250VAC, 49–63 Hz, 10VA, 5W maximum

11–26VAC/VDC, 10VA, 5W maximum

Input

Resolution: 18 bits

Sampling rate: 5 times/second

Maximum rating: -2VDC minimum, 12VDC maximum
(1 minute for mA input)

Temperature effect: $\pm 1.5\mu\text{V}/^\circ\text{C}$

Sensor lead resistance effect: T/C: $0.2\mu\text{V}/\text{ohm}$

Burn-out Current: 200nA

Common Mode Rejection Ratio (CMRR): 120dB

Sensor Break Detection:

Sensor open for TC

Sensor break responding time:

Within 4 seconds for TC

Characteristics:

Type	Range	Accuracy @ 25°C	Input Impedance
J	-120°C to 1000°C (-184°F to 1832°F)	$\pm 2^\circ\text{C}$	2.2 M Ω
K	-200°C to 1370°C (-328°F to 2498°F)	$\pm 2^\circ\text{C}$	2.2 M Ω
T	-250°C to 400°C (-418°F to 752°F)	$\pm 2^\circ\text{C}$	2.2 M Ω
E	-100°C to 900°C (-148°F to 1652°F)	$\pm 2^\circ\text{C}$	2.2 M Ω
B	0°C to 1800°C (32°F to 3272°F)	$\pm 2^\circ\text{C}$ (200°C to 1800°C)	2.2 M Ω
R	0°C to 1767.8°C (32°F to 3214°F)	$\pm 2^\circ\text{C}$	2.2 M Ω
S	0°C to 1767.8°C (32°F to 3214°F)	$\pm 2^\circ\text{C}$	2.2 M Ω
N	-250°C to 1300°C (-418°F to 2372°F)	$\pm 2^\circ\text{C}$	2.2 M Ω
L	-200°C to 900°C (-328°F to 1652°F)	$\pm 2^\circ\text{C}$	2.2 M Ω
C	0°C to 2315°C (32°F to 4199°F)	$\pm 2^\circ\text{C}$	2.2 M Ω
P	0°C to 1395°C (32°F to 2543°F)	$\pm 2^\circ\text{C}$	2.2 M Ω

Table 5.1 Input Characteristics

Characteristics:

Event Input

Logic Low: -10V minimum, 0.8V maximum.

Logic High: 2V minimum, 10V maximum.

Functions: Remote reset, remote lockout.

Output 1/Output 2

Relay Rating: 2A/240VAC, 200,000 life cycles for resistive load.

Pulsed Voltage: Source voltage 5V, current limiting resistance 66 ohms.

DC Voltage Supply Characteristics (Installed at Output 2)

Type	Tolerance	Max. Output Current	Ripple Voltage	Isolation Barrier
20 V	$\pm .5\text{ V}$	25 mA	0.2 Vp-p	500 VAC
12 V	$\pm 0.3\text{ V}$	40 mA	0.1 Vp-p	500 VAC
5 V	$\pm 0.15\text{ V}$	80 mA	0.05 Vp-p	500 VAC

Data Communication

Interface: RS-232 (1 unit), RS-485 (up to 247 units)

Protocol: Modbus protocol RTU mode

Address: 1–247

Baud Rate: 0.3~38.4 Kbits/sec

Data Bits: 8 bits

Parity Bit: None, even or odd

Stop Bit: 1 or 2 bits

Communication Buffer: 50 bytes

Analog Retransmission

Output Signal: 4-20 mA, 0-20 mA, 0-5V, 1-5V, 0-10V

Resolution: 15 bits

Accuracy: $\pm 0.05\%$ of span $\pm 0.0025\%/^{\circ}\text{C}$

Load Resistance: 0-500 ohms (for current output)
10K ohms minimum (for voltage output)

Output Regulation: 0.01% for full load change

Output Settling Time: 0.1sec (stable to 99.9%)

Isolation Breakdown Voltage: 1000 Vac for 1 min.

Integral Linearity Error: $\pm 0.005\%$ of span

Temperature Effect: $\pm 0.0025\%$ of span/ $^{\circ}\text{C}$

Saturation Low: 0 mA or (0V)

Saturation High: 22.2 mA (or 5.55V, 11.1V/min)

Linear Output Range: 0-22.2 mA (0-20 mA or 4-20 mA)
0-5.55V (0-5V, 1-5V)
0-11.1 V (0-10V)

User Interface

Dual **4-digit LED Displays**

Keypad: 4 keys

Programming Port: For automatic setup, calibration, and testing.

Communication Port: Connection to PC for supervisory control.

Limit Control: High limit, low limit and high/low limit programmable

Digital Filter

Function: First order

Time Constant: 0, 0.2, 0.5, 1, 2, 5, 10, 20, 30, 60 seconds programmable

Environmental and Physical

Operating temperature: -10°C to 50°C

Storage temperature: -40°C to 60°C

Humidity: 0 to 90% RH (non-condensing)

Altitude: 2000 m maximum

Pollution: Degree 2

Insulation resistance: 20 Mohms min. (at 500VDC)

Dielectric strength: 2000VAC, 50/60 Hz for 1 minute

Vibration resistance: 10–55 Hz, 10 m/s² for 2 hours

Shock resistance: 200m/s² (20g)

Moldings: Flame retardant polycarbonate

Dimensions: 3-3/4 × 3-3/4 × 2-9/16" H × W × D
(96 × 96 × 65 mm)
Depth behind panel: 2" (53 mm)

Weight: 250 grams

Approval Standards

Safety: FM Class 3534 (Oct. 1998)

UL61010C-1

EN61010-1 (IEC1010-1)

Protective class:

IP65 for panel with additional option

IP50 for panel without additional option

IP20 for terminals and housing with protective cover.

All indoor use.

EMC: EN61326

Chapter 6 Modbus Communications

6-1 Functions Supported

Only function 03, 06 and 16 are available for this series of controllers. The message formats for each function are described as follows:

This chapter specifies the Modbus Communications protocol as RS-232 or RS-485 interface module is installed. Only RTU mode is supported. Data is transmitted as eight-bit binary bytes with 1 start bit, 1 stop bit and optional parity checking (None, Even or Odd). Baud rate may be set to 300, 600, 1200, 2400, 4800, 9600, 14400, 19200, 28800 and 38400.

Function 03: Read Holding Registers

Query: (from Master)	Response: (from Slave)
Slave address (0-255)	←
Function code (3)	←
Starting address of register Hi (0)	Byte count
Starting address of register Lo (0-61, 128-143)	Data 1 Hi
No. of words Hi (0)	Data 1 Lo
No. of words Lo (1-22)	Data 2 Hi
CRC16 Hi	Data 2 Lo
CRC16 Lo	•
	•
	•
	•
	•
	CRC16 Hi
	CRC16 Lo

Function 06: Preset Single Register

Query: (from Master)	Response: (from slave)
Slave address (0-255)	←
Function code (6)	←
Register address Hi (0)	←
Register address Lo (0-61, 128-143)	←
Data Hi	←
Data Lo	←
CRC16 Hi	←
CRC16 Lo	←

Function 16: Preset Multiple Registers

Query: (from master)	Response: (from slave)
Slave address (0-255)	←
Function code (16)	←
Starting address of register Hi (0)	←
Starting address of register Lo (0-61, 128-143)	←
No. of words Hi (0)	←
No. of words Lo (1-18)	←
Byte count (2-36)	CRC16 Hi
Data 1 Hi	CRC16 Lo
Data 1 Lo	
Data 2 Hi	
Data 2 Lo	
•	
•	
•	
•	
•	
CRC16 Hi	
CRC16 Lo	

6-2 Exception Responses

If the controller receives a message which contains a corrupted character (parity check error, framing error etc.), or if the CRC16 check fails, the controller ignores the message. However, if the controller receives a syntactically correct message which contains an illegal value, it will send an exception response, consisting of five bytes as follows:

slave address +offset function code + exception code + CRC16 Hi +CRC16 Lo

Where the offset function code is obtained by adding the function code with 128 (ie. function 3 becomes H'83), and the exception code is equal to the value contained in the following table:

Exemption Code	Name	Cause
1	Bad Function Code	Function code is not supported by the controller
2	Illegal data address	Register address out of range
3	Illegal data value	Data value out of range or attempt to write a read-only or protected data

6-3 Parameter Table

Register Address	Parameter Notation	Parameter	Scale Low	Scale High	Notes
0		Reserved			
1	HSP1	High Limit Set Point 1	*1	*1	R/W
2	LSP1	Low Limit Set Point 1	*1	*1	R/W
3	SP2	Set Point 2 value for output 2	*1	*1	R/W
4		Reserved			
5		Reserved			
6	PV.HI	Historical max. value of PV	*1	*1	R
7	PV.LO	Historical min. value of PV	*1	*1	R
8		Reserved			
9	INPT	Input type selection	0	65535	R/W
10	UNIT	Process unit	0	65535	R/W
11	RESO	Display resolution	0	65535	R/W
12	IN.LO	Low scale value for linear input	*1	*1	R/W
13	IN.HI	How scale value for linear input	*1	*1	R/W
14	SNIF	PV shift (offset) value	*1	*1	R/W
15	FILT	PV filter time constant	0	65535	R/W
16	T.ABN	Accumulated time during abnormal condition	0	6553.5	R
17	OUT1	Output 1 function	0	65535	R/W
18		Reserved			
19		Reserved			
20	O1.HY	Output 1 hysteresis value	*2	*2	R/W
21		Reserved			R/W
22		Reserved			
23		Reserved			
24		Reserved			
25		Reserved			
26		Reserved			
27		Reserved			
28	HSP.L	Lower limit of HSP1	*1	*1	R/W
29	HSP.H	Upper limit of HSP1	*1	*1	R/W
30	LSP.L	Lower limit of LSP1	*1	*1	R/W
31	LSP.H	Upper limit of LSP1	*1	*1	R/W
32		Reserved			

Register Address	Parameter Notation	Parameter	Scale Low	Scale High	Notes
33		Reserved			
34	AOFN	Analog output function	0	65535	R/W
35	OUT2	Output 2 function	0	65535	R/W
36		Reserved			
37		Reserved			
38		Reserved			
39	COMM	Communication function	0	65535	R/W
40	ADDR	Address	0	65535	R/W
41	BAUD	Baud rate	0	65535	R/W
42	PARI	Parity bit	0	65535	R/W
43	AOLO	Analog output scale low	*1	*1	R/W
44	AL.FN	Alarm function	0	65535	R/W
45	AL.MD	Alarm mode	0	65535	R/W
46	AL.HY	Alarm hysteresis value	*2	*2	R/W
47	AL.FT	Alarm failure transfer	0	65535	R/W
48	EIFN	Event input function	0	65535	R/W
49	DISP	Normal Display format	0	65535	R/W
50	AOHI	Analog output scale high	*1	*1	R/W
51	ADO	mV calibration low coefficient	-1999.9	4553.6	R/W
52	ADG	mV calibration high coefficient	-1999.9	4553.6	R/W
53	CJTL	Cold junction calibration low coefficient	-199.99	455.36	R/W
54	CJG	Cold junction calibration high coefficient	-1999.9	4553.6	R/W
55	REF	RTD calibration low coefficient *	-1999.9	4553.6	R/W
56	SR	RTD calibration high coefficient *	-199.99	4553.6	R/W
57		Reserved			
58	DATE	Manufacturing date of the product	0	65535	R/W
59	NO	Serial number of the product	0	65535	R/W
60	HOUR	Working hours of the product	0	65535	R/W
61	HRLO	Fractional value of hour	0	65535	R/W
128	PV	Process value	*1	*1	R
129	HSP1L	High limit set point 1	*1	*1	R
130	LSP1	Low limit set point 1	*1	*1	R
131	T.ABN	Accumulated time during abnormal condition	0	6553.5	R
132	ALM	Output 1 status *4	0	65535	R
140	PROG	Program code *3	0.00	655.35	R
142	CMND	Command code	0	65535	R/W
143	JOB	Job code	0	65535	R/W

***Not Used On This Control**

*1 The scale high/low values are defined in the following table for the parameters HSP1, LSP1, SP2, PV.HI, PV.HO, IN.LO, IN.HI, SHIF, HSPL, HSP.H, LSPL, LSP.H, PV, SV, AOLO and AOHI:

Conditions	Non-linear input	Linear input RESO = 0	Linear input RESO = 1	Linear input RESO = 2	Linear input RESO = 3
Scale low	-1999.9	-19999	-1999.9	-199.99	-19.999
Scale High	4553.6	45536	4553.6	455.36	45.536

*2 The scale high/low values are defined in the following table for O1.HY, and AL.HY:

Conditions	Non-linear input	Linear input RESO = 0	Linear input RESO = 1	Linear input RESO = 2	Linear input RESO = 3
Scale low	0.0	0	0.0	0.00	0.000
Scale High	6553.5	65535	6553.5	655.35	65.535

*3: The PROG code is defined by 5.XX, where XX denotes the software version number.

For example : PROG=5.10 means the product is TEC-410 with software version 10.

*4: The least significant bit (LSB) of ALM shows the status of output 1.LSB=1 if output 1 is ON (normal condition). The second bit of ALM shows the status of output2.

6-4 Data Conversion

The word data are regarded as unsigned (positive) data in the Modbus message. However, the actual value of the parameter may be a negative value with decimal point. The high/low scale values for each parameter are used for the purpose of such conversion.

Let M = Value of Modbus message A = Actual value of the parameter
 SL = Scale low value of the parameter SH = Scale high value of the parameter

$$M = \left(\frac{65535}{SH - SL} \right) \times (A - SL) \qquad A = \left(\frac{SH - SL}{65535} \right) \times (M + SL)$$

6-5 Communication Examples:

Example 1: Download the default values via the programming port

The programming port can perform Modbus communications regardless of the incorrect setup values of address, baud, parity, stop bit, etc. It is especially useful during the first time configuration for the controller. The host must be set with 9600 baud rate, 8 data bits, even parity and 1 stop bit.

The Modbus message frame with hexadecimal values is shown as follows:

(1) Unlock the controller

	06	00	8E	68	2C	HI	LO
Addr.	Func.	Reg. Addr.	CMND=26668			CRC16	

(2) Preset the first group of the parameters

	10	00	09	00	07	0E	00	01	00	00	
Addr.	Func.	Starting Addr.	No. of words	Bytes	INPT=1		UNIT=0				
00	01	4E	1F	52	07	4E	1F	00	02	HI	LO
RESO=1		IN.LO=0		IN.HI=100.0		SHIF=0.0		FILT=2		CRC16	

(3) Preset the second group of the parameters

	10	00	01	00	03	06	52	07	4E	1F	51	A3	HI	LO
Addr.	Func.	Starting Addr.	No. of words	Bytes	HSP1=100.0		LSP1=0.0		SP2=90.0		CRC16			

(4) Preset the third group of the parameters

	10	00	11	00	13	26	00	02	00	00	00	00	00	01	
Addr.	Func.	Starting Addr.	No. of words	Bytes	OUT1=2		Reserved		Reserved		O1.HY=0.1				
00	00	00	00	00	00	00	00	00	00	00	00	00	4E	1F	
Reserved		Reserved		Reserved		Reserved		Reserved		Reserved		HSP.L=0			
75	2F	4A	37	4E	1F	00	00	00	00	00	00	00	02	HI	LO
HSP.H=1000.0		LSP.L=-100.0		LSP.H=0		Reserved		Reserved		AOFN=0		OUT2=2		CRC16	

(5) Preset the rest parameters

	10	00	27	00	0C	18	00	01	00	01	00	05	00	00
Addr.	Func.	Starting Addr.	No. of words	Bytes	COMM=1		ADDR=1		BAUD=5		PARI=0			
4E	1F	00	06	00	00	00	01	00	01	00	00	00	00	00
AOLO=0		AL.FN=6		AL.MD=0		AL.HY=0.1		AL.FT=1		EIFN=0		DISP=0		
52	07	HI	LO											
AOHI=100.0		CRC16												

Example 2: Read the process value (PV)

Send the following message to the controller via the COMM port or the programming port :

Query

	03	00	80	00	01	HI	LO
Addr.	Func.	Starting Addr.	No. of words		CRC16		

Example 3: Perform reset function (same effect as pressing  key):

Query

	06	00	8E	68	25	HI	LO
Addr.	Func.	Starting Addr.	CMND=26661		CRC16		

Example 4: Read 22 parameters at most one time

Query

	03			00	16	HI	LO
Addr.	Func.	Starting Addr.	No. of words		CRC16		

Example 5: Modify the calibration coefficient

Preset the CMND register with 26665 before attempting to change the calibration coefficient.

	06	00	8E	68	29	HI	LO
Addr.	Func.	Register Addr.	CMND=26665		CRC16		

Table A.1 Error Codes and Corrective Actions

Error Code	Display Symbol	Error Description	Corrective Action
10	<i>Er 10</i>	Communication error: bad function code	Correct the communication software to meet the protocol requirements.
11	<i>Er 11</i>	Communication error: register address out of range	Don't issue an over-range register address to the slave.
14	<i>Er 14</i>	Communication error: attempt to write a read-only data or a protected data	Don't write a read-only data or a protected data to the slave.
15	<i>Er 15</i>	Communication error: write a value which is out of range to a register	Don't write an over-range data to the slave register.
39	<i>SEn.b</i>	Input sensor break	Replace input sensor.
40	<i>Ad.Er</i>	A to D converter or related component(s) malfunction	Return to factory for repair.

RETURNS

No product returns can be accepted without a completed Return Material Authorization (RMA) form.

TECHNICAL SUPPORT

Technical questions and troubleshooting help is available from Tempco. When calling or writing please give as much background information on the application or process as possible.

E-mail: techsupport@tempco.com

Phone: 630-350-2252

800-323-6859

Note: Information in this manual was deemed correct at the time of printing. The policy of Tempco is one of continuous development and product improvement, and we reserve the right to modify specifications and designs without prior notice. Not responsible for typographical errors.

Custom Manufacturer Since 1972

ELECTRIC HEATING ELEMENTS • TEMPERATURE CONTROLS • SENSORS • PROCESS HEATING SYSTEMS

HEAT THINGS UP!

With Thousands of Design Variations
We Make Everything You Need.

Band Heaters	Cartridge Heaters
Cast-In Heaters	Coil & Cable Heaters
Radiant Heaters	Strip Heaters
Flexible Heaters	Tubular Heaters
Process Heaters	Instrumentation
Temperature Control	Temperature Sensors



607 N. Central Avenue Wood Dale, IL 60191-1452 USA
P: 630-350-2252 Toll Free: 800-323-6859
F: 630-350-0232 E: info@tempco.com
www.tempco.com