

TEMPCO®

USER MANUAL

TEC-9090

Self-Tune Fuzzy Logic
PID Process Temperature Controller



NOTE:

It is strongly recommended that a process should incorporate a LIMIT CONTROL like TEC-910 which will shut down the equipment at a preset process condition in order to preclude possible damage to products or system.

Information in this user's manual is subject to change without notice.

Copyright © 2021, Tempco Electric Heater Corporation, all rights reserved. No part of this publication may be reproduced, transmitted, transcribed or stored in a retrieval system, or translated into any language in any form by any means without the written permission of Tempco Electric Heater Corporation.

Contents

	Page Number
Chapter 1 Introduction	1
Chapter 2 Ordering Code	2
Chapter 3 Front Panel Description ..	3
Chapter 4 Input Range and Accuracy	3
Chapter 5 Specifications	4
Chapter 6 Installation	
6-1 Dimensions and Panel Cutout	5
6-2 Wiring Diagram	5
Chapter 7 Wiring Precautions	6
Chapter 8 Operation	
8-1 Keypad Operation	6
8-2 Flow Chart	7
8-3 Parameter Description	7
8-4 Automatic Tuning	8
8-5 Manual PID Adjustment	8
8-6 Manual Tuning Procedure	9
8-7 Ramp and Dwell	9
Chapter 9 Error Messages	11

Figures & Tables

	Page Number
Figure 1.1 Fuzzy Control Advantage.....	1
Figure 3.1 Front Panel Description	3
Figure 6.1 Mounting Dimensions and Panel Cutout	5
Figure 6.2 Wiring Diagram	5
Figure 8.1 Manual Tuning Procedure	9
Figure 8.2 Ramp and Dwell Example	10
Table A.1 Error Codes and Corrective Actions ..	11
Appendix	
Returns	11

Chapter 1 Introduction

This manual contains information for the installation and operation of the Tempco model TEC-9090 fuzzy logic microprocessor based controller.

Fuzzy logic is an essential feature of this versatile controller. Although PID control has been widely accepted by many industries, it is difficult for PID control to work efficiently with some sophisticated systems, such as second order systems, systems with long time-lag, varying set points, varying loads, etc. Because of the disadvantages of the controlling principles and fixed values of PID control, it is inefficient when controlling systems with a lot of variables, and the result is below expectations for some systems. Fuzzy logic control can overcome these disadvantages of PID control. The function of fuzzy logic is to

adjust the PID values indirectly in order to make the manipulation of output value MV adapt flexibly and quickly to varying processes. In this way, it enables a process to reach its predetermined set point in the shortest amount of time with minimum overshooting during tuning or external disturbance. Unlike PID control which uses digital information, fuzzy logic uses language information.

In addition, this instrument has the functions of single stage ramp and dwell, auto-tuning, and manual mode execution. It is also easy to use.

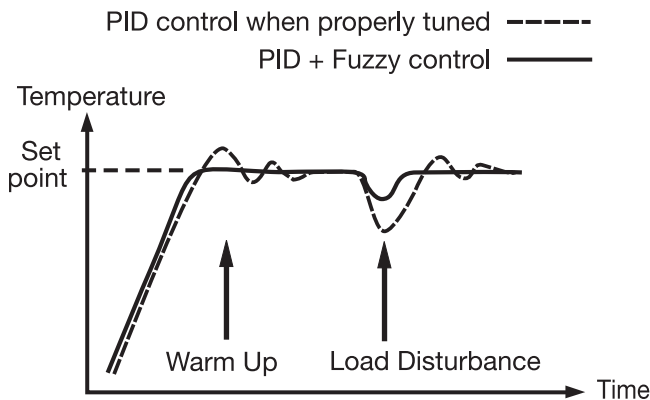
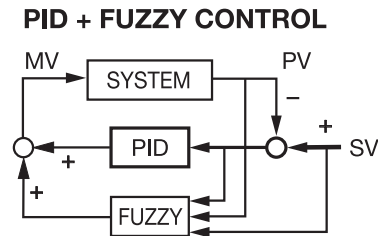

Figure 1.1
Fuzzy Control
Advantage



Chapter 2 Ordering Code

TEC-9090 —

(1) (2) (3) (4) (5) (6) (7) (8)

(1) Power Input

4	90-264VAC
5	20-32VDC/VAC
9	Other

(2) Signal Input

5	Configurable (Universal)
9	Other

(3) Range Code

1	Configurable
9	Other

(4) Control Mode

3	PID / ON-OFF Control
---	----------------------

(5) Output 1 Option

0	None
1	Relay rated 3A/240VAC resistive
2	SSR Drive rated 20mA/24V
3	4-20mA linear, max. load 500 ohms (Module OM93-1)
4	0-20mA linear, max. load 500 ohms (Module OM93-2)
5	0-10V linear, min. impedance 500K ohms (Module OM93-3)
9	Other

(6) Output 2 Option

0	None
---	------

(7) Alarm Option

0	None
1	Relay rated 2A/240VAC resistive
9	Other

(8) Communication

0	None
---	------

Chapter 3 Front Panel Description

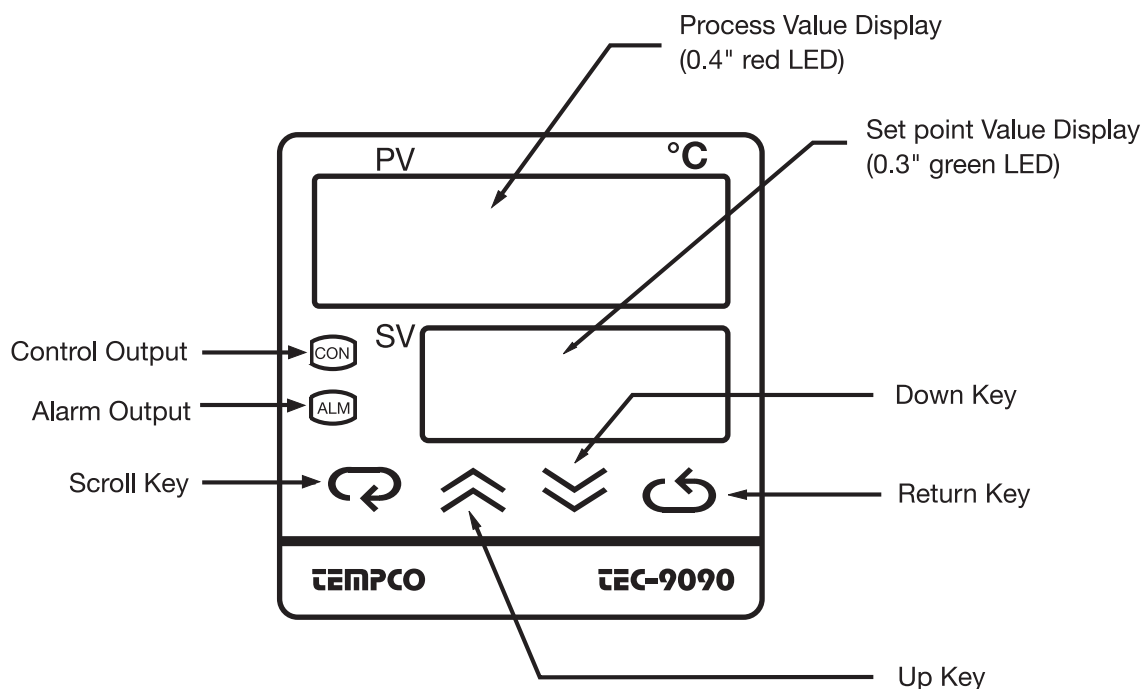

Figure 3.1
Front Panel Description

Chapter 4 Input Range and Accuracy

Sensor	Input Type	Range (°F)	Accuracy (°F)	Range (°C)	Accuracy (°C)
J	Iron/Constantan	-58 to 1832°F	±3.6°F	-50 to 1000°C	±2°C
K	Chromel/Alumel	-58 to 2500°F	±3.6°F	-50 to 1370°C	±2°C
T	Copper/Constantan	-454 to 752°F	±3.6°F	-270 to 400°C	±2°C
E	Chromel/Constantan	-58 to 1382°F	±3.6°F	-50 to 750°C	±2°C
B	Pt30%RH/Pt6%RH	32 to 3272°F	±5.4°F	0 to 1800°C	±2°C
R	Pt13%RH/Pt	32 to 3182°F	±3.6°F	0 to 1750°C	±2°C
S	Pt10%RH/Pt	32 to 3182°F	±3.6°F	0 to 1750°C	±2°C
N	Nicrosil/Nisil	-58 to 2372°F	±3.6°F	-50 to 1300°C	±2°C
RTD	PT 100 ohms (DIN)	-328 to 752°F	±0.72°F	-200 to 400°C	±0.4°C
RTD	PT 100 ohms (JIS)	-328 to 752°F	±0.72°F	-200 to 400°C	±0.4°C
Linear	Voltage or Current	-1999 to 9999	±.05%	-1999 to 9999	±.05%

Chapter 5 Specifications

Input

Thermocouple (T/C):	Type J, K, T, E, B, R, S, N.
RTD:	PT100ohm RTD (DIN 43760/BS1904 or JIS)
Linear:	-10 to 60mV, configurable input attenuation
Range:	User configurable, refer to table above
Accuracy:	Refer to table above
Cold junction compensation:	0.1°F/°F ambient typical
Sensor break protection:	Protection mode configurable
External resistance:	100ohms max.
Normal mode rejection:	60dB
Common mode rejection:	120dB
Sample rate:	3 times/second

Control

Proportion band:	0–360°F (0–200°C)
Reset (integral):	0–3600 seconds
Rate (derivative):	0–1000 seconds
Ramp rate:	0–360.0°F/minute (0–200.0°C/minute)
Dwell:	0–3600 minutes
ON-OFF:	With adjustable hysteresis (0–20% of SPAN)
Cycle time:	0–120 seconds
Control action:	Direct (for cooling) and reverse (for heating)

Power

Rating:	90–264VAC, 50/60Hz or low voltage (note label)
Consumption:	Less than 5VA

Environmental and Physical

Safety:	UL873, IEC1010-1 (EN61010-1) EN50081-1
EMC emission:	EN50082-2
EMC immunity:	14–122°F (-10 to 50°C)
Operating temperature:	0 to 90% RH (non-condensing)
Humidity:	20Mohms min. (500VDC)
Insulation:	AC 2000V, 50/60Hz, 1 minute
Breakdown:	10–55 Hz, amplitude 1mm
Vibration:	200m/s (20g)
Shock:	170 grams
Net weight:	Poly-carbonate plastic
Housing materials:	

Chapter 6 Installation

6-1 Dimensions and Panel Cutout

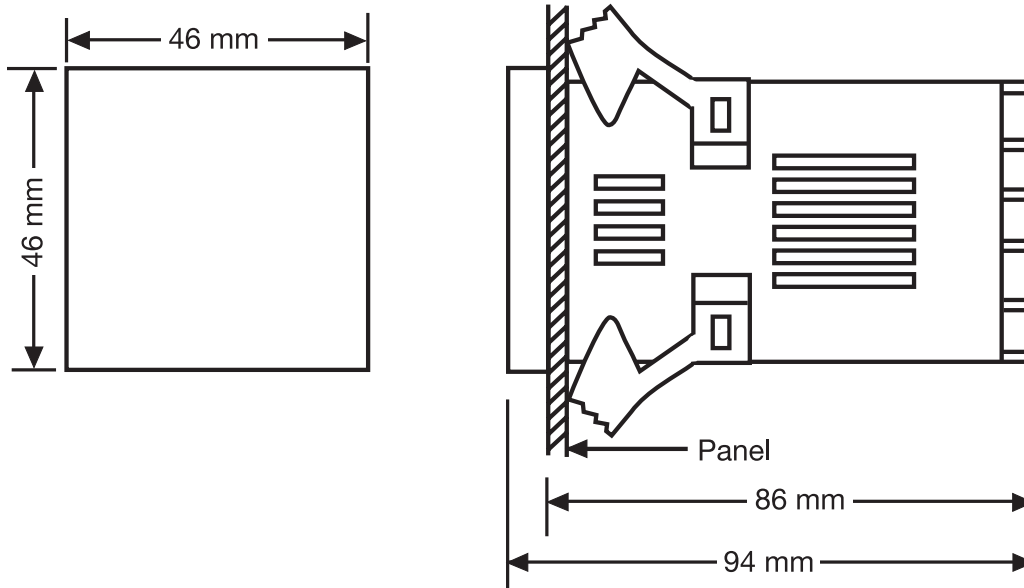

Figure 6.1 Mounting Dimensions

6-2 Wiring Diagram

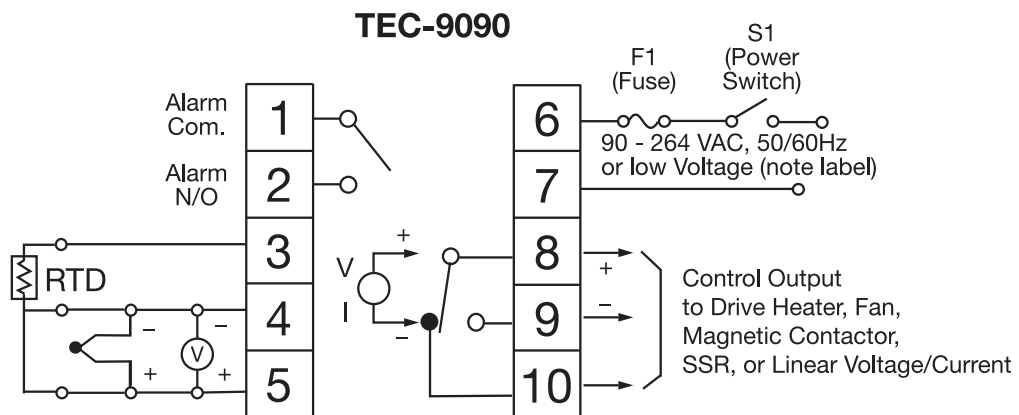











Figure 6.2 Wiring Diagram

Chapter 7 Wiring Precautions

- Before wiring, verify the correct model number and options on the label. Switch off the power while checking.
- Care must be taken to ensure that the maximum voltage rating specified on the label is not exceeded.
- It is recommended that the power for these units be protected by fuses or circuit breakers rated at the minimum value possible.
- All units should be installed in a suitable enclosure to prevent live parts from being accessible to human hands and metal tools. Metal enclosures and/or subpanels should be grounded in accordance with national and local codes.
- All wiring must conform to appropriate standards of good practice and local codes and regulations. Wiring must be suitable for the voltage, current, and temperature rating of the system.
- Beware not to over-tighten the terminal screws. The torque should not exceed 1 N-m (8.9 lb-in or 10 KgF-cm).
- Unused control terminals should not be used as jumper points as they may be internally connected, causing damage to the unit.
- Verify that the ratings of the output devices and the inputs as specified are not exceeded.
- Except for thermocouple wiring, all wiring should use stranded copper conductor with a maximum gage of 14 AWG.
- Electrical power in industrial environments contains a certain amount of noise in the form of transient voltage and spikes. This electrical noise can adversely affect the operation of microprocessor-based controls. For this reason the use of shielded thermocouple extension wire which connects the sensor to the controller is strongly recommended. This wire is a twisted-pair construction with foil wrap and drain wire. The drain wire is to be attached to ground in the control panel only.

Chapter 8 Operation

8-1 Keypad Operation

TOUCHKEYS	FUNCTION	DESCRIPTION
	Scroll Key	Advance the index display to the desired position. Index advanced continuously and cyclically by pressing this keypad.
	Up Key	Increases the parameter
	Down Key	Decreases the parameter
	Return Key	Resets the controller to its normal status. Also stops auto-tuning, output percentage monitoring and manual mode operation.
Press  for 6 seconds	Long Scroll	Allows more parameters to be inspected or changed.
Press  for 6 seconds	Long Return	1. Executes auto-tuning function 2. Calibrates control when in calibration level
Press  and 	Output Percentage Monitor	Allows the set point display to indicate the control output value.
Press  and  for 6 seconds	Manual Mode Execution	Allows the controller to enter the manual mode.

*With power on, it takes 12 seconds to memorize the new values of parameters once they have been changed.

8-2 Flow Chart

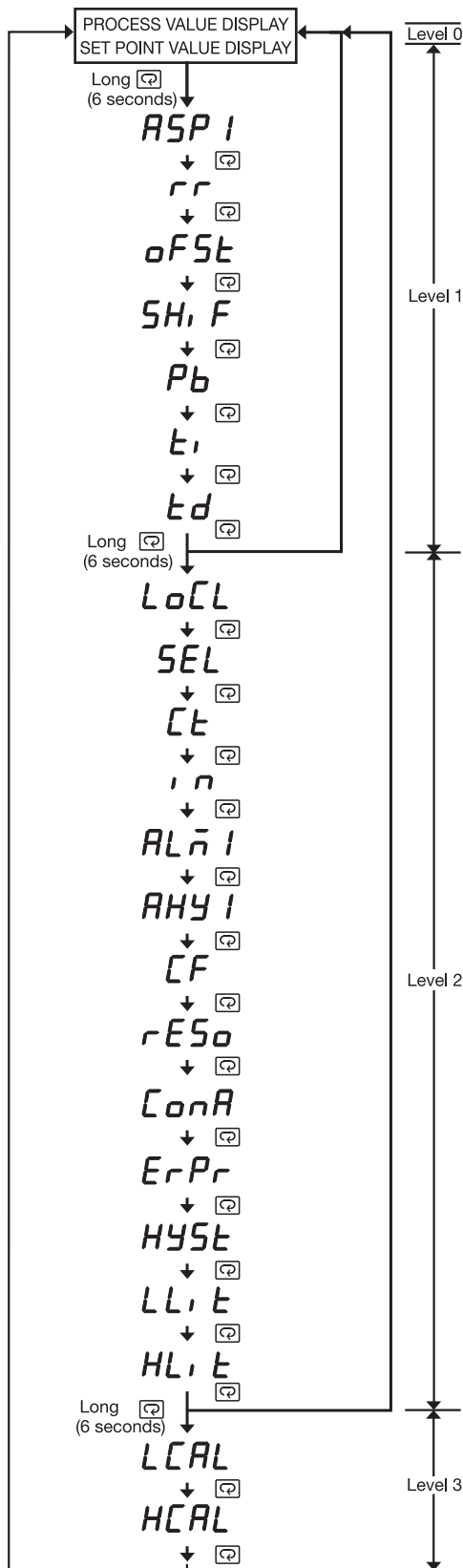

The "return" key can be pressed at any time. This will prompt the display to return to the Process value/Set point value.

Power Applied:

1. **9090 436** Displayed for 4 seconds. (Software Version 3.6 or higher)
2. **8888 8888** LED test. All LED segments must be lit for 4 seconds.
3. Process value and set point indicated.

8-3 Parameter Description

Index Code	Description Adjustment Range	**Default Setting
SV	Set point Value Control *Low Limit to High Limit Value	392°F (200°C)
ASP I	Alarm Set point Value * Low Limit to High Limit value. (if $AL\bar{n} I=0, 1, 4, \text{ or } 5$) * 0 to 3600 minutes (if $AL\bar{n} I=12 \text{ or } 13$) * Low Limit minus set point to High Limit minus set point value (if $AL\bar{n} I=2, 3, 6, \text{ or } 11$)	18°F (10°C)
rr	Ramp Rate for the process value to limit an abrupt change of process (soft start) * 0 to 360.0° F (200.0°C)/minute (if $r = 0 \text{ to } 9$) * 0 to 3600 unit / minute (if $r = 10$)	0°F / min.
oFSt	Offset Value for Manual Reset (if $t_i = 0$) * 0 to 100%	0.0%
SH, F	Offset shift for process value * -199° F to 199° F (-111°C to 111°C)	0°F
Pb	Proportional Band * 0 to 360° F (0 to 200°C) (set to 0 for on-off control)	18°F (10°C)
t _i	Integral (Reset) Time * 0 to 3600 seconds	120 sec.
t _d	Derivative (Rate) Time * 0 to 1000 seconds	30 sec.
LoCL	Local Mode 0: No control parameters can be changed 1: Control parameters can be changed	1
SEL	Parameter Selection (allows selection of additional parameters to be accessible at level 0 security) 0: None 1: ASP I 2: rr 3: oFSt 4: ASP I, rr 5: ASP I, oFSt 6: rr, oFSt 7: ASP I, rr, oFSt	0
Ct	Proportional Cycle Time * 0 to 120 seconds	Relay 20 Pulsed Voltage 1 Linear Volt/mA 0
in	Input Mode Selection 0: J type T/C 1: K type T/C 2: T type T/C 3: E type T/C 4: B type T/C 5: R type T/C 6: S type T/C 7: N type T/C 8: PT100 DIN 9: PT100 JIS 10: Linear Voltage or Current Note: T/C-Close solder gap G5, RTD-Open G5	T/C 0 RTD 8 Linear 10
ALn I	Alarm Mode Selection 0: Process High Alarm 1: Process Low Alarm 2: Deviation High Alarm 3: Deviation Low Alarm 4: Inhibit Process High Alarm 5: Inhibit Process Low Alarm 6: Inhibit Deviation High Alarm 7: Inhibit Deviation Low Alarm 8: Outband Alarm 9: inband Alarm 10: Inhibit Outband Alarm 11: Inhibit Inband Alarm 12: Alarm Relay OFF as Dwell Time Out 13: Alarm Relay ON as Dwell Time Out	2
AHY I	Hysteresis of Alarm 1 * 0 to 20% of SPAN	0.5%
CF	°C/°F Selection 0:°F 1:°C	0
rESo	Resolution Selection 0: No Decimal Point 1: 1 Digit Decimal 2: 2 Digit Decimal 3: 3 Digit Decimal (2 and 3 may only be used for linear voltage or current $r = 10$)	0
ConA	Control Action 0: Direct (Cooling) Action 1: Reverse (Heat) Action	1
ErPr	Error Protection 0: Control OFF, Alarm OFF 1: Control OFF, Alarm ON 2: Control ON, Alarm OFF 3: Control ON, Alarm ON	1
HYS t	Hysteresis for ON/OFF Control *0 to 20% of SPAN	0.5%
LL, t	Low Limit of Range	-58°F (-50°C)
HL, t	High Limit of Range	1832°F (1000°C)
LCAL	Low Calibration Figure	32°F (0°C)
HCAL	High Calibration Figure	1112°F (600°C)

NOTES: * Adjusting Range of the Parameter
** Factory settings. Process alarms are at fixed temperature points. Deviation alarms move with the set points value.

8-4 Automatic Tuning

1. Ensure that the controller is correctly configured and installed.
2. Ensure that the proportional band “PB” is not set at “0”.
3. Press the return key for at least 6 seconds (maximum 16 seconds). This initializes the auto-tune function. (To abort auto-tuning procedure, press and release the return key).
4. The decimal point in the lower right hand corner of the PV display flashes to indicate that auto-tuning is in progress. Auto-tune is complete when the flashing stops.

5. Depending on the particular process, automatic tuning may take up to two hours. Processes with long time lags will take the longest to tune. Remember, while the display point flashes, the controller is auto-tuning.

NOTE: If an AT error (*AT Err*) occurs, the automatic tuning process is aborted due to the system operating in ON-OFF control mode (PB=0). The process will also be aborted if the set point is set too close to the process temperature or if there is insufficient capacity in the system to reach the set point (e.g., inadequate heating power available). Upon completion of auto-tuning, the new PID settings are automatically entered into the controller's non-volatile memory.

8-5 Manual PID Adjustment

Although the auto-tuning function will select control settings which should prove satisfactory for the majority of processes, you may find it necessary to make adjustments to these settings from time to time. This may be the case if some changes are made to the process or if you wish to fine-tune the control settings.

It is important, prior to making changes to the control settings, that you record the current settings for future reference. Make only slight changes to one setting at a time and observe the results on the process. Because each of the settings interacts with the others, it is easy to become confused with the results if you are not familiar with process control procedures.

Tuning Guide

Proportional Band	
Symptom	Solution
Slow Response	Decrease PB Value
High Overshoot or Oscillations	Increase PB Value

Integral Time (Reset)	
Symptom	Solution
Slow Response	Decrease Integral Time
Instability or Oscillations	Increase Integral Time

Derivative Time (Rate)	
Symptom	Solution
Slow Response or Oscillations	Decrease Derivative. Time
High Overshoot	Increase Derivative Time

8-6 Manual Tuning Procedure

- Step 1: Adjust the integral and derivative values to 0. This inhibits the rate and reset action
- Step 2: Set an arbitrary value for proportional band and monitor the control results
- Step 3: If the original setting introduces a large process oscillation, then gradually increase the proportional band until steady cycling occurs. Record this proportional band value (P_c).
- Step 4: Measure the period of steady cycling

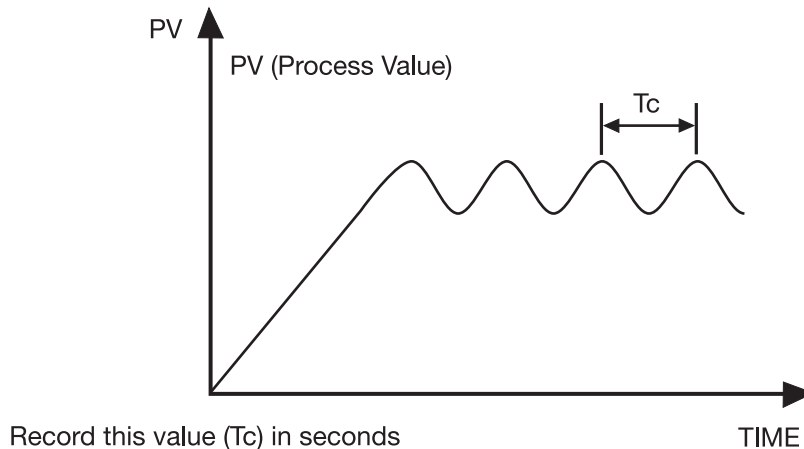

Figure 8.1
Manual Tuning Process

- Step 5: The control settings are determined as follows:
- Proportion band (PB) = $1.7 P_c$
 - Integral time (TI) = $0.5 T_c$
 - Derivative time (TD) = $0.125 T_c$

8-7 Ramp and Dwell

The TEC-9090 controller can be configured to act as either a fixed set point controller or as a single ramp controller on power up. This function enables the user to set a pre-determined ramp rate to allow the process to gradually reach the set point temperature, thus producing a “soft start” function.

A dwell timer is incorporated within the TEC-9090 and the alarm relay can be configured to allow the dwell function to be used in conjunction with the ramp function.

The ramp rate is determined by the “ r_r ” parameter which can be adjusted within the range of 0 to $200.0^{\circ}\text{C}/\text{minute}$. The ramp rate function is disabled when the “ r_r ” parameter is set to “0”.

The soak function is enabled by configuring the alarm output to act as a dwell timer. The parameter $ALN1$ needs to be set with a value of 12. The alarm contact will now operate as a timer contact, with the contact closed at power up and opening after the elapsed time set in parameter $ASP1$.

If the controller power supply or output is wired through the alarm contact, the controller will operate as a guaranteed soak controller.

continued...

In the example below, the ramp rate is set at 5°F/minute, $ALN I = 12$ and $ASP I = 15$ (minutes). Power is applied at zero time and the process climbs at 5°F/minute to the set point of 125°F. Upon reaching the set point, the dwell timer is activated, and after the soak time of 15 minutes, the alarm contact will open, switching off the output. The process temperature will eventually fall at an undetermined rate.

The dwell function may also be used to operate an external device such as a siren to alert when a soak time has been reached.

$ALN I$ needs to be set with a value of 13. The alarm contact will now operate as a timer contact, with the contact being open on the initial start up. The timer begins to count down once the set point temperature is reached. After the setting at $ASP I$ has elapsed, the alarm contact closes.

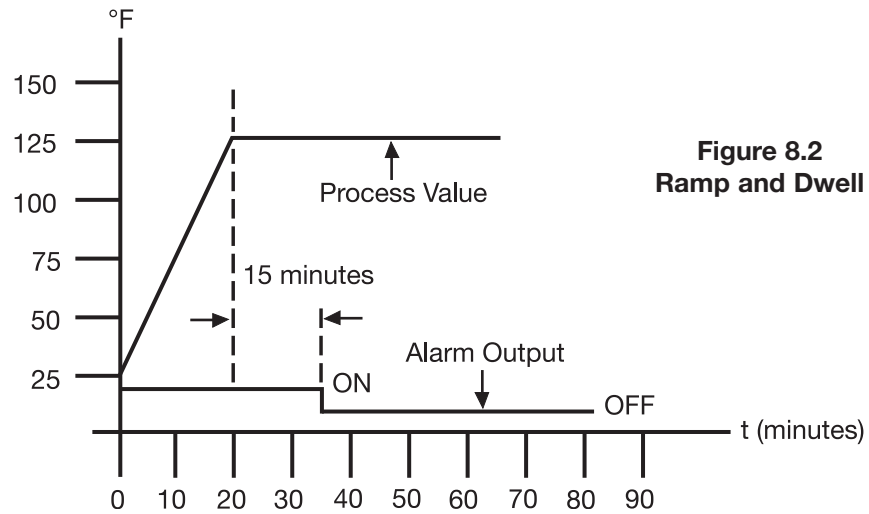

Figure 8.2
Ramp and Dwell

Chapter 9 Error Messages

Display Symbol	Error Description	Corrective Action
<i>SbEr</i>	Sensor break error	Replace RTD or sensor Use manual mode operation
<i>LLEr</i>	Process display beyond the low range set point	Re-adjust <i>LL, L</i> value
<i>HLEr</i>	Process display beyond the high range set point	Re-adjust <i>HL, L</i> value
<i>AHEr</i>	Analog hybrid module damage	Replace module. Check for outside source of damage such as transient voltage spikes
<i>ALEr</i>	Incorrect operation of auto tune procedure Prop. Band set to 0	Repeat procedure. Increase Prop. Band to a number larger than 0
<i>oPEr</i>	Manual mode is not allowable for an ON-OFF control system	Increase proportional band
<i>CSEr</i>	Check sum error, values in memory may have changed accidentally	Check and reconfigure the control parameters

RETURNS

No product returns can be accepted without a completed Return Material Authorization (RMA) form.

TECHNICAL SUPPORT

Technical questions and troubleshooting help is available from Tempco. When calling or writing please give as much background information on the application or process as possible.

TEMPCO Electric Heater Corporation

607 N. Central Avenue

Wood Dale, IL 60191-1452 USA

E-mail: techsupport@tempco.com

Phone: 630-350-2252 Toll Free: 800-323-6859

Web: Tempco.com

Note: Information in this manual was deemed correct at the time of printing. The policy of Tempco is one of continuous development and product improvement, and we reserve the right to modify specifications and designs without prior notice. Not responsible for typographical errors.

Custom Manufacturer Since 1972

ELECTRIC HEATING ELEMENTS • TEMPERATURE CONTROLS • SENSORS • PROCESS HEATING SYSTEMS

HEAT THINGS UP!

With Thousands of Design Variations
We Make Everything You Need.

Band Heaters	Cartridge Heaters
Cast-In Heaters	Coil & Cable Heaters
Radiant Heaters	Strip Heaters
Flexible Heaters	Tubular Heaters
Process Heaters	Instrumentation
Temperature Control	Temperature Sensors



607 N. Central Avenue Wood Dale, IL 60191-1452 USA
P: 630-350-2252 Toll Free: 800-323-6859
F: 630-350-0232 E: info@tempco.com
www.tempco.com