

# TEMPCO®

## USER MANUAL

**TPC20073 - Power Control Console (2 zones)  
with On-Off Switch Per Zone**  
with TEC-9400 (PID + Fuzzy Logic Process Controllers)  
240VAC, 50/50Hz, Fused at 15A  
with Alarm Lamps and Buzzers





## SPECIFICATIONS

**Temperature Controllers:** Model TEC-9400, 1/16 DIN Dual Display with PID Auto-tuning

**Sensor Inputs:** Type J thermocouples

**Connector Bodys:** Bulk head, 5-PIN

**Power Cord/voltage Input:** 240VAC, 50/60 HZ, 15A

**Heater Outputs:** 6A Max, 1440 watts max per zone.

**Output Devices:** Solid State Relays

**Main Power Switch:** Located on front panel

**Fuse Main Power:** See replacement parts list on next page (located on back panel)

**Fuse Control Power:** See replacement parts list on next page (located on back panel)

## WARNINGS



1. Air vents located on top and bottom of console must not be blocked! To prevent an overheating condition the internal components must remain as close to room temperature (75°F / 24°C) as possible.
2. Dangerous voltage capable of causing injury or death is present within this console. Power to all equipment must be disconnected before installation or beginning any troubleshooting procedures. **Heater output wiring and component replacement must be made by qualified personnel only.**
3. To minimize the possibility of fire or shock, do not expose this console to rain or excessive moisture.
4. Do not use this console in areas where hazardous conditions exist such as excessive shock, vibration, dirt, corrosive gases, oil or where explosive gases or vapors are present.
5. It is strongly recommended that a process should incorporate a Limit Control such as a Tempco TEC-910 which will shut down the equipment at a preset process condition in order to avoid possible damage to products or systems.

## WIRING (For safety, disconnect all power sources prior to wiring)

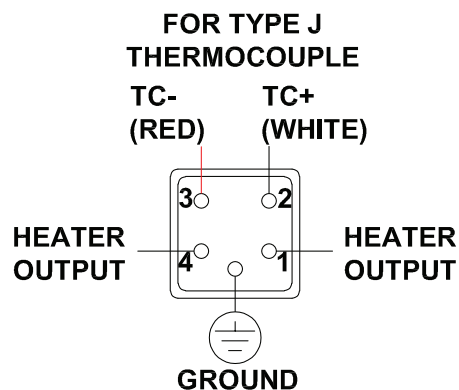
1. Attach the leads from your type K thermocouples and heaters to the bulkhead connectors noting the pinout diagram below: The heater output current is sourced directly through the line cord.



## OPERATION

1. Verify the power switch is in the off position. Plug your heaters & thermocouples into the rear connectors. Plug the provided line cord from the console into a 240V, 15A outlet. Switch on the console using independent switches.
2. Set your desired temperature setpoint by using the up and down arrow buttons on the TEC-9400 temperature controllers.
3. Refer to the following pages for complete operation and page 4 for auto-tuning of the TEC-9400 temperature controllers. The warning lights and buzzer are for indication only, they have no bearing on the heater power outputs.
4. The alarm lights and buzzer will NOT energize the first time the process temperature is within the band alarm area, such as on heat-up. The alarm light and buzzer WILL energize the second time the process temperature falls within the band alarm area. This is referred to as “Hold alarm action” and described on pages 11 and 16.
5. To change setpoint of alarm buzzer: Presently this is set to a Deviation-out of band alarm, 5°F traveling both above and below the setpoint.
  1. Press the scroll key  down for 5 seconds. The display should indicate SET – BASE.
  2. Press the up key so the display indicates SET – ALRM.
  3. Press the scroll key  approx 5 times so the display indicates A1DV (alarm 1 band deviation)
  4. Revise to your desired deviation value. Default setting is 5°F above and below the setpoint.
  5. Press the (R) button to return the “home” PV-SV display.

Other types of settings are described on page 15.

## SPARE REPLACEMENT PARTS

Tempco Part Number	Description
EHD-124-148	Fuses (2), rated 15 Amp/250V, ¼ x 1 ¼”, fast acting BUSS ABC-15-R. Used for main control console power.
EHD-124-276	Fuse, rated 1 Amp/ 250V, ¼” x 1¼”, fast acting, BUSS ABC-1-R. Used for TEC-9400 Controllers.
EHD-124-300	Fuses (2), rated 8 Amp/ 250V, ¼” x 1¼”, fast acting, BUSS ABC-8-R. Used for individual heater outputs.
EHD-102-231	Hubbell # HBL2321 Twist Lock Plug, 20A, 250V.
EHD-103-209	(2) Female Housing Bulkhead Connectors. Weidmuller 1652410000 or equal
EHD-103-210	(2) 4-Pin Female Inserts, Weidmuller 1498400000 or equal.

**NOTE:** For all fuses, use listed BUSS part numbers or equivalent.

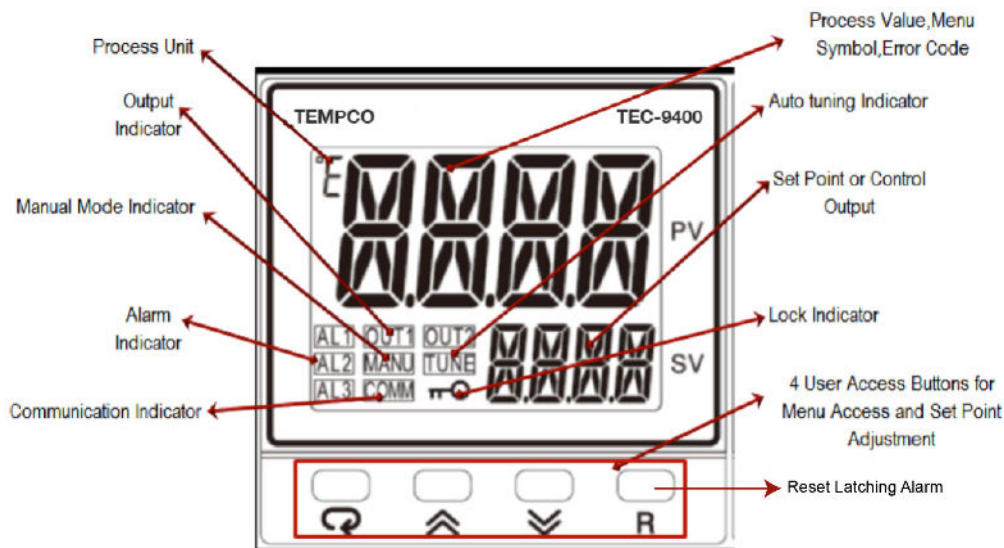

**TEC-9400 Front Panel Keys and Display**

## KEYPAD OPERATION

### SCROLL KEY:

This key is used to select a parameter to be viewed or adjusted.

### UP KEY:

This key is used to increase the value of the selected parameter.

### DOWN KEY:







This key is used to decrease the value of the selected parameter.

### RESET KEY:

This key is used to:

1. Revert the display to the home screen.
2. Reset a latching alarm once the alarm condition is removed.
3. Stop manual control mode, Auto-Tuning mode or calibration mode.
4. Clear an Auto-Tuning or communication error message.
5. Enter the manual control menu if failure mode occurs.

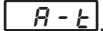
### ENTER KEY:

1. Press  and hold for 5 seconds to enter the setup menu. The display will show .
2. Press and hold  for 6.2 seconds, then let go to enter manual mode. The display will show .
3. Press and hold  for 7.4 seconds, then let go to select Auto-Tuning. The display will show .
4. Press and hold  for 8.6 seconds, then let go to select calibration mode.

During power-up, the upper display will show PROG, and the lower display will show the Firmware version.

# 1.1 Menu Flowchart

The Menu has been divided into 5 groups. They are as follows:

1. User Menu - Below
2. Setup Menu - Page 5
3. Manual Mode Menu - Page 7
4. Auto-Tuning Mode Menu - Page 7
5. Calibration Mode Menu (not recommended, calibration section has been removed)

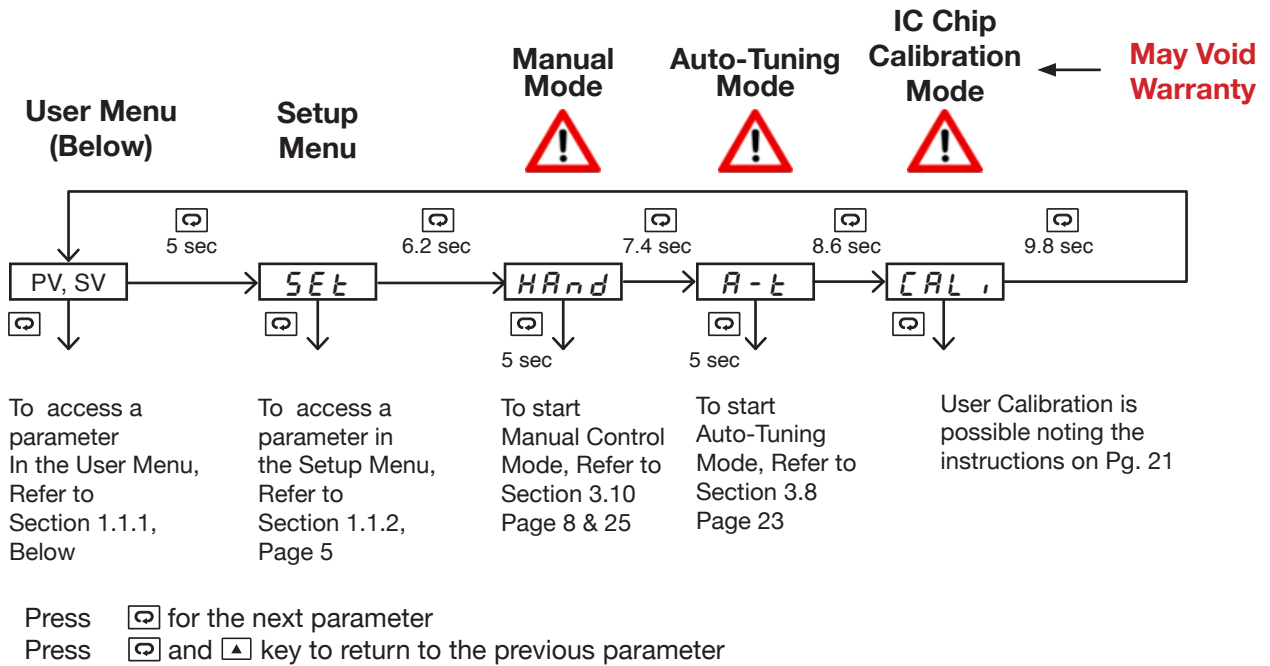

## 1.1.1 User Menu

The following user menu parameters are available depending on the current setup configuration of the controller.

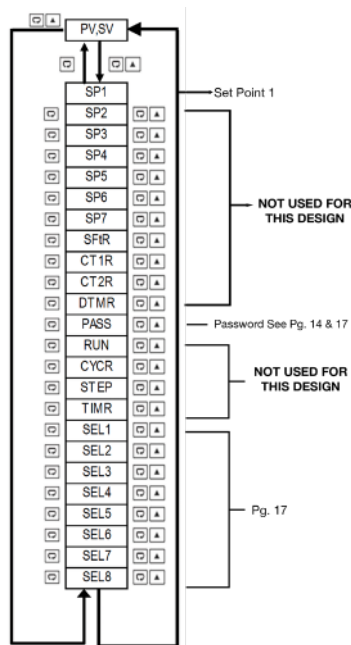



**NOTE PG. 26 FOR TEC-9400  
ERROR CODES**

### 1.1.2 Setup Menu

The setup menu has been categorized in to eight categories. They are listed below.

1. Basic Menu - Below
2. Output Menu (Pg. 6)
3. Alarm Menu (Pg. 7)
4. Event Input Menu \*
5. User Select Menu \*
6. Communication Menu \*
7. Current Transformer Menu \*
8. Profile Menu (Ramp and Soak) \*

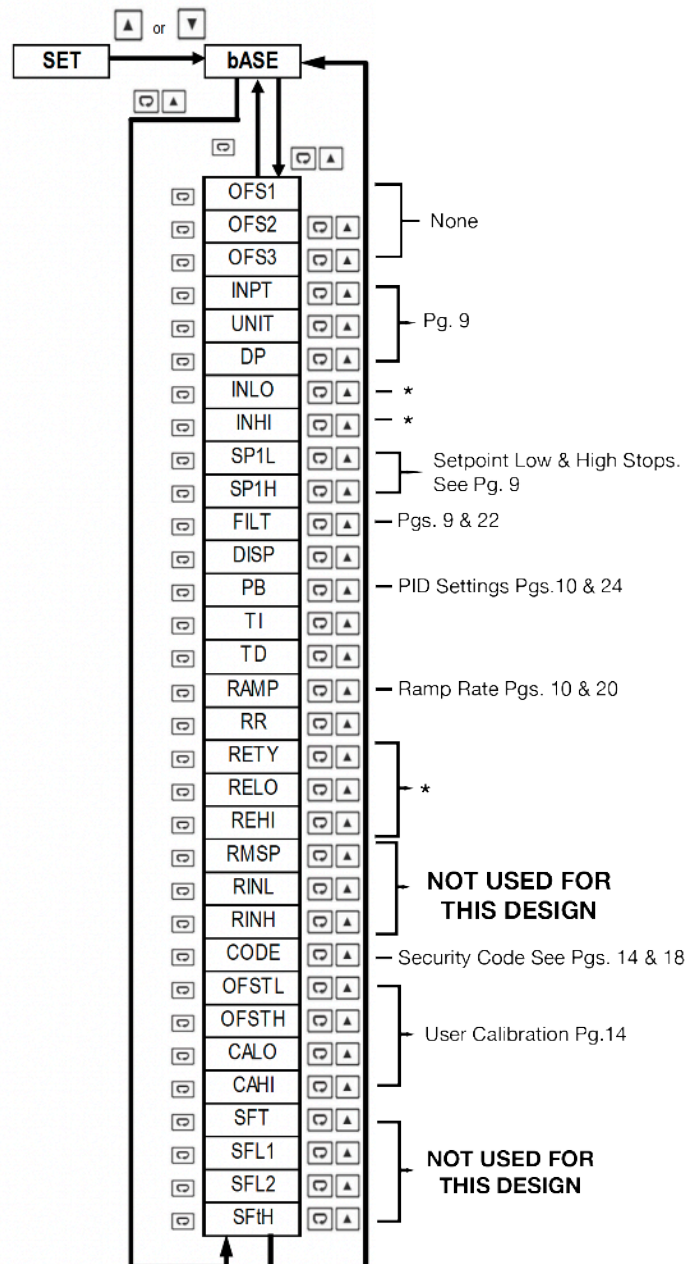

#### 1.1.2.1 Basic Menu (bASE)

In the setup menu, when the upper display says “SET”, Use the  or  keys to get “bASE” in the lower display. Then use the  key to cycle through the “bASE” menu parameters.



**\* NOT USED IN THIS DESIGN**

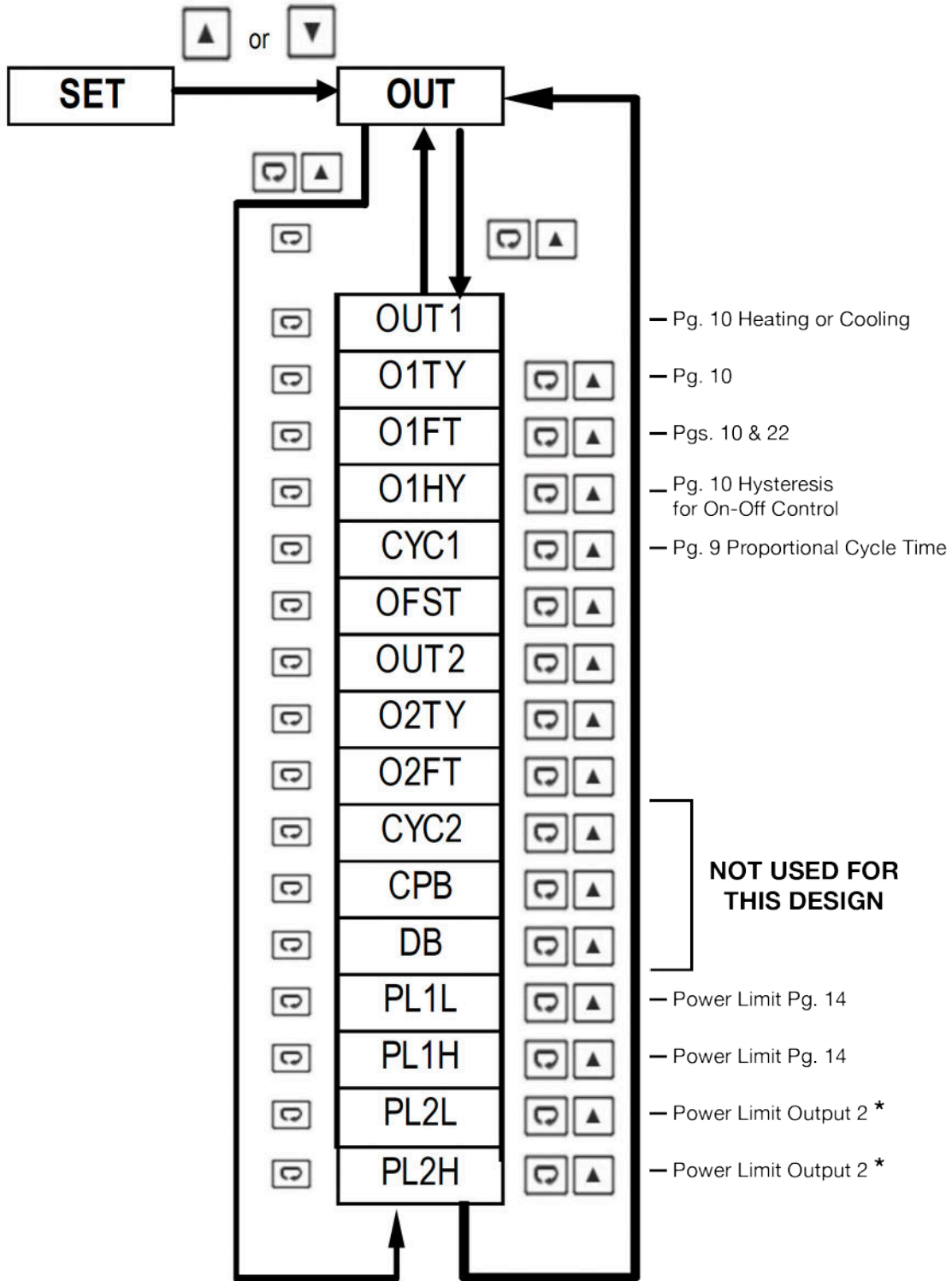

### 1.1.2.2 Output Menu (oUT)

In the setup menu, when the upper display says “SET”, use the  or  key to get “oUT” in the lower display. Then, use the  key to cycle through the “oUT” menu parameters.



**\* NOT USED IN THIS DESIGN**

### 1.7.2.3 Alarm Menu (ALRM) - Controls Lighted Buzzers

In the setup menu, when the upper display says “SET”, use the  or  key to get “ALRM” in the lower display. Then use the “” key to cycle through the “ALRM” menu parameters.

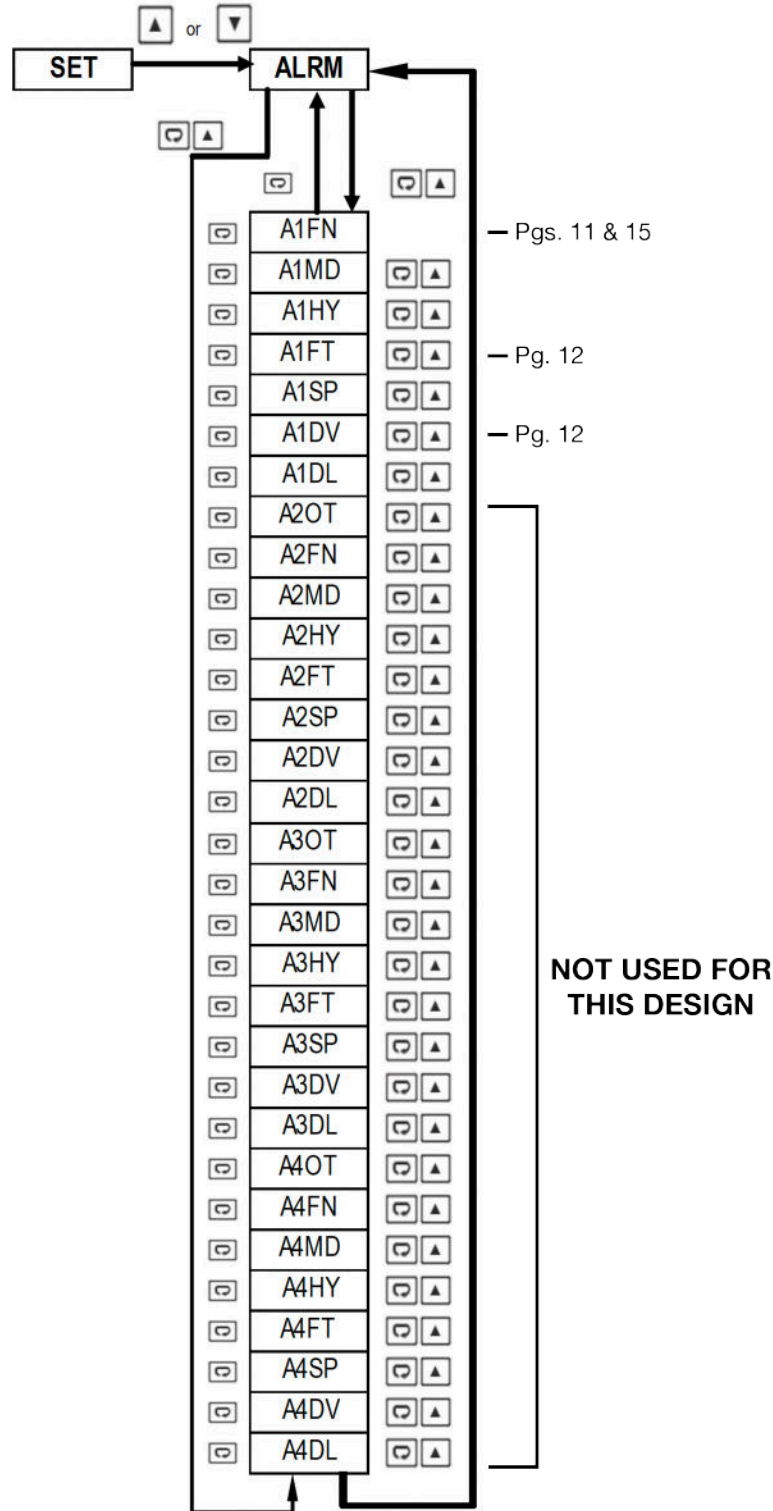

### 1.1.3 Manual Mode Menu - Used If Sensor Fails (See Pg. 25)

Press and hold the “

“Hx.xx” is used to adjust output 1.

“Cx.xx” is used to adjust output 2.

You are able to exit manual mode by pressing and holding the  key.

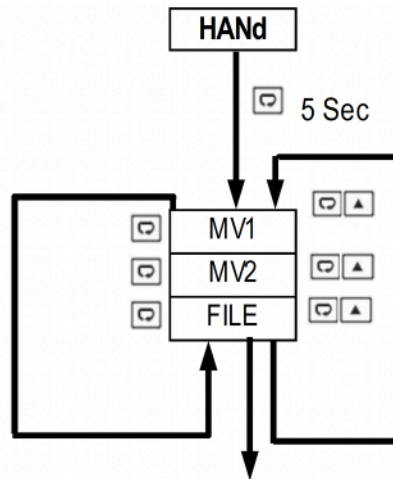

Press  key 5 Sec To execute the selected default program

### 1.7.4 Auto-Tuning Mode - Tunes PID Parameters to Your Application (See Pg. 16)

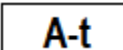

Press and hold the “

Press and hold the “

Auto-tuning allows the controller to find its own optimal control parameters (PID) by measuring the speed of your thermal process.

## 1.2 Parameter Description

(\*Parameters that are not applicable are not shown)

Register Address	Parameter Notation	Parameter Description	Range	Default Value
0	SP1	Set Point 1 (Used for Output 1)	Low: SP1L High: SP1H	77.0° F
8	INPT (See Pg. 18)	Input sensor selection	<b>0 J_tC:</b> J type Thermocouple <b>1 K_tC:</b> K type Thermocouple <b>2 T_tC:</b> T type Thermocouple <b>3 E_tC:</b> E type Thermocouple <b>4 B_tC:</b> B type Thermocouple <b>5 R_tC:</b> R type Thermocouple <b>6 S_tC:</b> S type Thermocouple <b>7 N_tC:</b> N type Thermocouple <b>8 L_tC:</b> L type Thermocouple <b>9 U_tC:</b> U type Thermocouple <b>10 P_tC:</b> P type Thermocouple <b>11 C_tC:</b> C type Thermocouple <b>12 D_tC:</b> D type Thermocouple <b>13 Pt.dN:</b> PT100 Ω DIN curve <b>14 Pt.JS:</b> PT100 Ω JIS curve <b>15 4-20:</b> 4-20mA linear current input <b>16 0-20:</b> 0-20mA linear current input <b>17 0-5V:</b> 0-5VDC linear voltage input <b>18 1-5V:</b> 1-5VDC linear voltage input <b>19 0-10:</b> 0-10VDC linear voltage input	0
9	UNIT	Input unit selection	<b>0 oC:</b> °C unit <b>1 oF:</b> °F unit <b>2 Pu:</b> Process unit	1
10	DP	Decimal point selection	<b>0 No.dP:</b> No decimal point <b>1 1-dP:</b> 1 decimal digit <b>2 2-dP:</b> 2 decimal digit <b>3 3-dP:</b> 3 decimal digit	0
13	SP1L	Low limit of set point 1 (Span Value)	Low: -19999 High :SP1H	0.0° F (-18.0° C)
14	SP1H	High limit of set point 1 (Span Value)	Low: SP1L High: 45536	1000.0° F (538° C)
15	FILT	Filter damping time constant of PV Sensor (See Pg. 22)	<b>0 0:</b> 0 second time constant <b>1 0.2:</b> 0.2 second time constant <b>2 0.5:</b> 0.5 second time constant <b>3 1:</b> 1 second time constant <b>4 2:</b> 2 second time constant <b>5 5:</b> 5 second time constant <b>6 10:</b> 10 second time constant <b>7 20:</b> 20 second time constant <b>8 30:</b> 30 second time constant <b>9 60:</b> 60 second time constant	2

Basic Menu

(\*Parameters that are not applicable are not shown)

Register Address	Parameter Notation	Parameter Description	Range	Default Value
17	PB (Pg. 24)	Proportional band value	Low: 0.0 High: 900.0°F (500.0°C)	18° F (8° C)
18	TI	Integral time value	Low: 0 High: 3600 sec	120
19	TD	Derivative time value	Low: 0.0 High: 360.0 sec	20
20	OUT1 (Pg. 20)	Output 1 function	<b>0 REVR:</b> Reverse (heating) control action <b>1 dIRt:</b> Direct (cooling) control action	0
21	O1TY  FACTORY SET, DO NOT CHANGE	Output 1 signal type	<b>0 RELY:</b> Relay output <b>1 SSrd:</b> Solid state relay drive output <b>2 4-20:</b> 4-20mA linear current <b>3 0-20:</b> 0-20mA linear current <b>4 0-5V:</b> 0-5VDC linear voltage <b>5 1-5V:</b> 1-5VDC linear voltage <b>6 0-10:</b> 0-10VDC linear voltage	1
22	O1FT	Output 1 failure transfer mode (See Pg. 22)	Select BPLS (Bumpless transfer), or 0.0 ~ 100.0 % to continue output 1 control function if the sensor fails, or select OFF (0) or ON (1) for ON-OFF control	0
23	O1HY	Output 1 ON-OFF control hysteresis. PB=0	Low: 0.1°C (0.2°F) High: 50.0°C (90.0°F)	0.2° F (0.1° C)
24	CYC1	Output 1 cycle time	Low: 0.1 High: 90.0 sec.	1.0
25	OFST	Offset value for P control	Low: 0 High: 100.0 %	25
26	RAMP	Ramp function selection (See Pg. 20)	<b>0 NoNE:</b> No Ramp Function <b>1 MINR:</b> Use °/minute as Ramp Rate <b>2 HRR:</b> Use °/hour as Ramp Rate	0
27	RR	Ramp rate	Low: 0.0 High: 900.0°F	0
28	OUT2	Output 2 function	<b>0 NoNE:</b> Output2 turned off <b>1 COOL:</b> Cooling PID Function <b>2 AL1:</b> Alarm 1 Function <b>3 rAL1:</b> Reverse Alarm 1 Function	2
29	O2TY  FACTORY SET, DO NOT CHANGE	Output 2 signal type	<b>0 RELY:</b> Relay output <b>1 SSrd:</b> Solid state relay drive output <b>2 4-20:</b> 4-20mA linear current <b>3 0-20:</b> 0-20mA linear current <b>4 0-5V:</b> 0-5VDC linear voltage <b>5 1-5V:</b> 1-5VDC linear voltage <b>6 0-10:</b> 0-10VDC linear voltage	0

\* Does not apply to this design

Register Address	Parameter Notation	Parameter Description	Range	Default Value	
30	O2FT	Output 2 failure transfer mode	Select BPLS (Bumpless transfer), or 0.0 ~ 100.0 % to continue output 2 control function if the sensor fails	100	
31	CYC2	Output 2 cycle time	Low: 0.1 High: 90.0 sec.	18	*
32	CPB	Cooling proportional band value	Low: 50 High: 300 %	100	*
33	DB	Heating-cooling dead band (negative value= overlap)	Low: - 36.0 High: 36.0 %	0	*
34	A1FN	Alarm 1 function for alarm 1 output (See Pg. 15)  Controls red lights and buzzer.	<b>0 NoNE:</b> No alarm function <b>1 dtMR:</b> Dwell timer action <b>2 dE.HI:</b> Deviation high alarm <b>3 dE.Lo:</b> Deviation low alarm <b>4 db.HI:</b> Deviation band out of band alarm <b>5 db.Lo:</b> Deviation band in band alarm <b>6 PV.HI:</b> Process value high alarm <b>7 PV.Lo:</b> Process value low alarm <b>8 H.bK:</b> Heater break alarm* <b>9 H.St:</b> Heater short alarm*	4	
35	A1MD	Alarm 1 operation mode (See pg. 16)	<b>0 NoRM:</b> Normal alarm action <b>1 LtCH:</b> Latching alarm action <b>2 HoLd:</b> Hold alarm action <b>3 Lt.Ho:</b> Latching & Hold action <b>4 SP.Ho:</b> Set point holding alarm	2	
36	A1HY	Hysteresis control of alarm1	Low: 0.1°C High: 90.0°F(50.0°C)	1.0 °F	

Output Menu

Alarm Menu

\* Does not apply to this design

Register Address	Parameter Notation	Parameter Description	Range	Default Value
37	A1FT	Alarm 1 failure transfer mode (See pg. 17)	<b>0 OFF:</b> Alarm output OFF if sensor fails <b>1 ON:</b> Alarm output ON if sensor fails	1
38	A1SP	Alarm 1 set point	Low: -19999 High: 45536	212.0°F (100.0 °C) *
39	A1DV	Alarm 1 deviation value	Low: -19999 High: 45536	5.0°F (6.0 °C)
40	A2OT	Alarm 2 Output	<b>0 ALM:</b> Alarm 2 output 1 <b>1 RALM:</b> Reverse Alarm 2 Output	0
41	A2FN	Alarm 2 function for alarm 2 output	<b>0 NoNE:</b> No alarm function <b>1 dtMR:</b> Dwell timer action <b>2 dE.HI:</b> Deviation high alarm <b>3 dE.Lo:</b> Deviation low alarm <b>4 db.HI:</b> Deviation band out of band alarm <b>5 db.Lo:</b> Deviation band in band alarm <b>6 PV.HI:</b> Process value high alarm <b>7 PV.Lo:</b> Process value low alarm <b>8 H.bK:</b> Heater break alarm <b>9 H.St:</b> Heater short alarm <b>10 E1.C.o:</b> Event Input 1 Control Alarm Output <b>11 E2.C.o:</b> Event Input 2 Control Alarm Output	0 *
42	A2MD	Alarm 2 operation mode	<b>0 NoRM:</b> Normal alarm action <b>1 LtCH:</b> Latching alarm action <b>2 HoLd:</b> Hold alarm action <b>3 Lt.Ho:</b> Latching & Hold action <b>4 SP.Ho:</b> Set point holding alarm	0
43	A2HY	Hysteresis control of alarm 2	Low: 0.1°C High: 90.0°F(50.0°C)	0.2° F (0.1° C)

Alarm Menu

\* Does not apply to this design

Register Address	Parameter Notation	Parameter Description	Range	Default Value
44	A2FT (Pg. 99)	Alarm 2 failure transfer mode	<b>0 OFF:</b> Alarm output OFF if sensor fails <b>1 ON:</b> Alarm output ON if sensor fails	1
45	A2SP	Alarm 2 set point	Low: -19999 High: 45536	100.0 °C (212.0°F)
46	A2DV	Alarm 2 deviation value	Low: -19999 High: 45536	10.0°C (18.0 °F)
47	A3OT	Alarm 3 output	<b>0 ALM:</b> Alarm 3 output <b>1 RALM:</b> Reverse Alarm 3 Output	0
48	A3FN (Pg. 93)	Alarm 3 function for alarm 3 output	<b>0 NoNE:</b> No alarm function <b>1 dtMR:</b> Dwell timer action <b>2 dE.HI:</b> Deviation high alarm <b>3 dE.Lo:</b> Deviation low alarm <b>4 db.HI:</b> Deviation band out of band alarm <b>5 db.Lo:</b> Deviation band in band alarm <b>6 PV.HI:</b> Process value high alarm <b>7 PV.Lo:</b> Process value low alarm <b>8 H.bK:</b> Heater break alarm <b>9 H.St:</b> Heater short alarm <b>10 E1.C.o:</b> Event Input 1 Control Alarm Output <b>11 E2.C.o:</b> Event Input 2 Control Alarm Output	2
49	A3MD (Pg. 94)	Alarm 3 operation mode	<b>0 NoRM:</b> Normal alarm action <b>1 LtCH:</b> Latching alarm action <b>2 HoLd:</b> Hold alarm action <b>3 Lt.Ho:</b> Latching & Hold action <b>4 SP.Ho:</b> Set point holding alarm	0
50	A3HY (Pg. 93)	Hysteresis control of alarm 3	Low: 0.1°C High: 90.0°F (50.0°C)	0.2°F (0.1°C)
51	A3FT (Pg. 95)	Alarm 3 failure transfer mode	<b>0 OFF:</b> Alarm output OFF if sensor fails <b>1 ON:</b> Alarm output ON if sensor fails	1
52	A3SP	Alarm 3 set point	Low: -19999 High: 45536	212.0°F (100.0°C)
53	A3DV	Alarm 3 deviation value	Low: -19999 High: 45536	18.0°F (10.0°C)

Alarm Menu

\*

\* Does not apply to this design

	Register Address	Parameter Notation	Parameter Description	Range	Default Value	
Output Menu	61	PL1L	Output 1 Low Power limit	Low: 0 High: PL1H or 50%	0	
	62	PL1H	Output 1 High Power limit	Low: PL1L High: 100 %	100	
Basic Menu	70	RETY	Retransmission type	<b>0 E.PV:</b> Retransmit process value <b>1 RE.SP:</b> Retransmit set point value	0	*
	71	RELO	Retransmission low scale value	Low: -19999 High: 45536	0	*
	72	REHI	Retransmission high scale value	Low: -19999 High: 45536	1000	*
User Menu	94	PASS	Password entry (See Pg. 18)	Low: 0 High: 9999	0	*
Basic Menu	95	CODE	Security code for parameter protection (See Pg. 18)	Low: 0 High: 9999 0 = unprotected 1000 = user mode unprotected 9999 = SPx(1 to 7) unprotected		
	96	OFTL	Offset value for low point calibration (See Pg. 21)	Low: -1999 High: 1999	0	
	97	OFTH	Offset value for high point calibration (See Pg. 21)	Low: -1999 High: 1999	0	
	98	CALO	Input signal value during low point calibration (See Pg. 21)	Low: -19999 High: CAHI-1	0	
	99	CAHI	Input signal value during high point calibration (See Pg. 21)	Low: CALO+1 High: 45536	1000	

**\* Does not apply to this design**

## 2.1 Alarm

The controller has up to four alarm outputs depending on the controller model. There are 11 types of alarm functions and one dwell timer that can be selected. There are 4 kinds of alarm modes (A1MD, A2MD, A3MD, and A4MD) available for each alarm function (A1FN, A2FN, A3FN, and A4FN). In addition to the alarm output, output 2 can also be configured as an alarm. But output 2 has only provides 8 different alarm functions or dwell timer available.

### 2.1.1 Alarm Types

There are 11 different types of alarms as listed below that the user can assign to different alarm outputs.

1. **dtMR**: Dwell timer\*
2. **dE.HI**: Deviation high alarm
3. **dE.Lo**: Deviation low alarm
4. **dB.Hi**: Deviation band out of band alarm – Used for this design
5. **dB.Lo**: Deviation band in band alarm
6. **PV.HI**: Process value high alarm
7. **PV.Lo**: Process value low alarm
8. **H.bK**: Heater break alarm\*
9. **H.St**: Heater short alarm\*
10. **E1.C.o**: Event Input 1 Control Alarm Output\*
11. **E2.C.o**: Event Input 2 Control Alarm Output\*

#### **\*DOES NOT APPLY TO THIS DESIGN**

**Types 2 & 3:** A deviation alarm alerts the user when the process value deviates too far from the set point. When the process value is higher than  $SV+A1DV$ , a **deviation high alarm (dE.HI)** occurs. The alarm is off when the process value is lower than  $SV+A1DV-A1HY$ . When the process value is lower than  $SV+A1DV$ , a **deviation low alarm (dE.Lo)** occurs. The alarm is off when the process value is higher than  $SV+A1DV+A1HY$ . The trigger level of a deviation alarm is moves with the set point.

**Types 4 & 5:** A deviation band alarm presets two trigger levels centered on the set point. The two trigger levels are  $SV+A1DV$  and  $SV-A1DV$ . When the process value is higher than  $(SV+A1DV)$  or lower than  $(SV - A1DV)$ , a **deviation band high alarm (dB.HI)** occurs. When the process value is within the trigger levels, a **deviation band low alarm (dB.Lo)** occurs.

In the above descriptions, SV denotes the current set point value for control. This is different from SP1 when the ramp function is used.

**Types 6 & 7:** A process alarm can set two absolute trigger levels. When the process value is higher than A1SP, a **process high alarm (PV.HI)** occurs. The alarm is off when the process value is lower than A1SP-A1HY. When the process value is lower than A1SP, a **process low alarm (PV.Lo)** occurs. The alarm is off when the process is higher than A1SP+A1HY. A process alarm is independent of the set point.

\*In the above description A1SP and A1HY denote Alarm1 Set point and Alarm1 Hysteresis. The respective Set point and Hysteresis parameters need to be set for other Alarm outputs.

## 2.1.2 Alarm Modes

There are five types of alarm modes available for each alarm function.

1. Normal alarm
2. Latching alarm - Press "R" key to unlatch alarm
3. Holding alarm
4. Latching / Holding alarm - Press "R" key to unlatch alarm
5. Set point Holding Alarm

### 2.1.2.1 Normal Alarm: ALMD = NORM

When a normal alarm is selected, the alarm output is de-energized in the non-alarm condition and energized in an alarm condition.

### 2.1.2.2 Latching Alarm: ALMD = LTCH

If a latching alarm is selected, once the alarm output is energized, it will remain unchanged even if the alarm condition is cleared. The latching alarm can be reset by pressing the "R" key once the alarm condition is no longer present.

### 2.1.2.3 Holding Alarm: ALMD = HOLD

A holding alarm prevents an alarm condition during power up. This will ignore the alarm condition the first time after initial powering on of the controller. Afterwards, the alarm performs the same function as a normal alarm.

### 2.1.2.4 Latching / Holding Alarm: ALMD = LT.HO

A latching / holding alarm performs both holding and latching functions. The latching alarm can be reset by pressing the "R" key once the alarm condition is no longer present.

### 2.1.2.5 Set Point Holding Alarm: ALMD = SP.HO

A set point holding alarm prevents an alarm during power up or when changing the set point. The alarm output is de-energized whenever the set point is changed even if it is in an alarm condition. The alarm reverts to a normal alarm once the alarm condition is removed.

### 2.2.3 Alarm Delay

In certain applications during startup, nuisance alarms can occur before the process value reaches the set point. To avoid these kinds of nuisance alarms, a time delay for alarms is available. To enable the time delay for alarms, set the delay time using the A1DL, A2DL, A3DL, and A4DL parameters. These parameters will help to avoid nuisance alarms until the process value reaches set point.

For example, let's say the set point set to 100°F. When the process approaches 100F, it could oscillate between 103°F and 97°F. During this time the Deviation/Process Hi Alarm would be activated and deactivated continuously. To avoid these kind of nuisance alarms, the alarm delay function can be used. It will generate the alarm after the PV is in alarm condition for a pre-determined period of time (AxDL setting).

The alarm delay can be configured in minutes and seconds.

### 2.2.4 Alarm Failure Transfer

Alarm Failure transfer is activated if the controller no longer detects an input sensor. The respective Alarm will energize if A1FT-A4FT is set to "ON" and will turn off if A1FT-A4FT is set to "OFF".

## 2.2 User Select Menu Configuration



Conventional controllers are designed with parameters in a fixed order.

If the user needs a friendlier menu operation to suit their application, most conventional controllers do not offer a solution. The LCD Series controllers have the flexibility for the user to select those parameters which are most significant, and put these parameters in an easy access USER menu.

There are eight user friendly parameters from the below list that can be set for user select menu configuration using the SEL1-SEL8 parameters.

- |          |          |          |
|----------|----------|----------|
| 1. SP2   | 12. A1dV | 23. PL1H |
| 2. DTMR  | 13. A2HY | 24. PL2L |
| 3. DISP  | 14. A2SP | 25. PL2H |
| 4. Pb    | 15. A2dV | 26. OFTL |
| 5. Td    | 16. A3HY | 27. OFTH |
| 6. TI    | 17. A3SP | 28. CALO |
| 7. o1HY  | 18. A3dV | 29. CAHI |
| 8. CPb   | 19. A4HY | 30. A1DL |
| 9. dB    | 20. A4SP | 31. A2DL |
| 10. A1HY | 21. A4dV | 32. A3DL |
| 11. A1SP | 22. PL1L | 33. A4DL |

### 3 PROGRAMMING

Press and hold  for 5 seconds, then release to enter the setup menu. Press and release  to cycle through the list of parameters. The upper display indicates the parameter symbol, and the lower display indicates the value of the selected parameter.

#### 3.1 User Security

There are two parameters, PASS (password) and CODE (security code), which will control the lockout program.

CODE Value	PASS Value	Access Rights
0	Any Value	All parameters are changeable
500	=500	All parameters are changeable
	≠500	All parameters are changeable except calibration parameters
1000	=1000	All parameters are changeable
	≠1000	Only user menu parameters changeable
9999	=9999	All parameters are changeable
	≠9999	Only SP1 to SP7 are changeable
Others	=CODE	All parameters are changeable
	≠CODE	No parameters can be changed

#### 3-1. User Access Rights

#### 3.2 Signal Input

**INPT:** Select the desired sensor type or signal type for the signal input

**Options:** (Thermocouple) J\_TC, K\_TC, T\_TC, E\_TC, B\_TC, R\_TC, S\_TC, N\_TC, L\_TC  
(RTD) PT.DN, PT.JS

(Linear) 4-20, 0-20, 0-60, 0-1V, 0-5V, 1-5V, 0-10

**UNIT:** Select the desired process unit

**Options:** °C, °F, PU (Process unit). If the unit is neither °C nor °F, then is set to PU.

**DP:** Select the desired resolution (decimal points) for the process value.

**Range:** For Thermocouple and RTD Signal NO.DP, 1-DP and For Linear Signal NO.DP, 1- DP, 2-DP, 3-DP

**INLO:** Select the low scale value for the linear type input.

**INHI:** Select the high scale value for the linear type input.

#### Example of How to use INLO and INHI:

A 4-20mA current loop pressure transducer with range of 0-15 kg/cm is connected to the input.

INPT = 4-20, INLO = 0.00, INHI = 15.00, DP = desired number of decimal points (3 decimals max)

### 3.3 Control Output

There are 4 kinds of control modes can be configured as shown below.

#### 3.3.1 Heat Only ON-OFF Control – (Used for Solenoids and Valves)

Select REVR for OUT1, Set PB to 0. O1HY is used to adjust the hysteresis for ON-OFF control. The output 1 hysteresis (O1HY) setting is only available when PB = 0. The heat only ON-OFF control function is shown below.

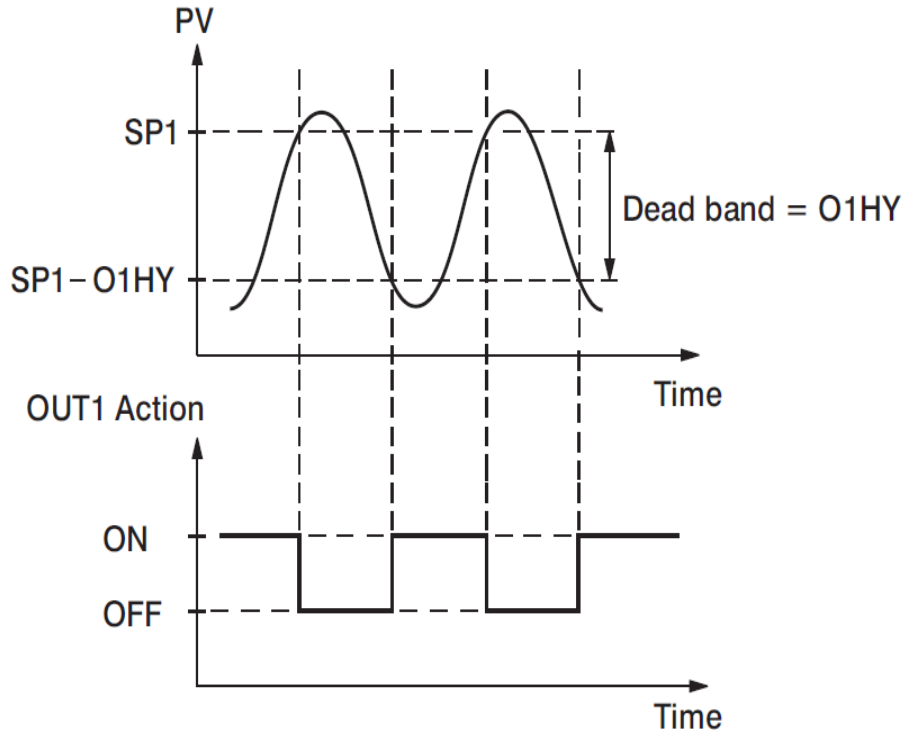

**3-1. Heat Only ON-OFF Control**

#### 3.3.2 Heat only P or PD Control – (Used for Electric Heaters)

Select REVR for OUT1, set TI = 0, OFST is used to adjust the control offset (manual reset). If PB ≠ 0 then O1HY will be hidden.

**OFST Function:** OFST is measured in % with a range of 0 - 100.0 %. When the process is stable, let's say the process value is lower than the set point by 5°F. Let's also say that 20.0 is used for the PB setting. In this example, 5°F is 25% of the proportional band (PB).

By increasing the OFST value by 25%, the control output will adjust itself, and the process value will eventually coincide with the set point.

When using Proportional (P) control (TI = 0), Auto-Tuning will be unavailable. Refer to the “manual tuning” section for the adjustment of PB and TD. Manual reset (OFST) is usually not practical because the load may change from time to time; meaning the OFST setting would need to be constantly adjusted. PID control can avoid this problem.

#### 3.3.3 Heat only PID Control – (Default for Electric Heaters)

Select REVR for OUT1. PB and TI should not be zero. Perform Auto-Tuning for initial startup. If the control result is not satisfactory, use manual tuning or try Auto-Tuning a second time to improve the control performance.

### 3.3.4 Cool only Control

ON-OFF control, Proportional control, and PID control can be used for cooling control. Set “OUT1” to DIRT (direct action).

**NOTE:** ON-OFF control may result in excessive overshoot and undershoot in the process. Proportional control could result in a deviation of the process value from the set point. It is recommended to use PID control for Heating or Cooling control to produce a stable process value.

When selecting parameters, all of the above parameters may not be available. The number of visible parameters depends on the configuration of the controller.

## 3.4 Ramp

The ramping function is performed during power up or any time the set point is changed. Choose “MINR” (ramp in minutes) or “HRR” (ramp in hours) for the “RAMP” setting, and the controller will perform the ramping function. The ramp rate is programmed by adjusting the “RR” setting. The ramping function is disabled whenever the controller enters Failure mode, Manual control mode, Auto-Tuning mode or Calibration mode.

### 3.4.1 Ramping Example without Dwell Timer

Set the “RAMP” setting to “MINR” to ramp in minutes.

Set the ramp rate (RR) to 10.

The starting temperature is 30°C.

The setpoint is initially set to 200°C.

After the process warms up, the user changed the setpoint to 100°C after 30 minutes.

After power up, the process will behave as shown below.

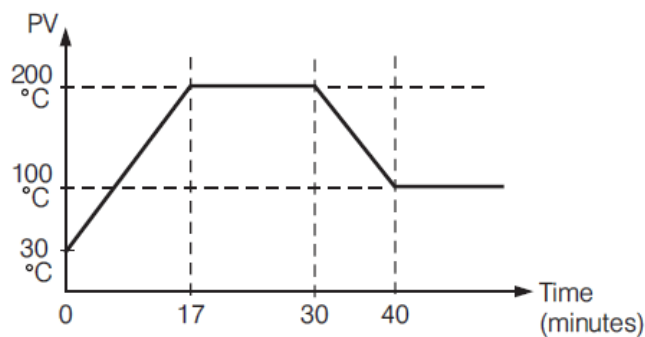

### 3-2. Ramp Function

**Note:** When the ramp function is used, the lower display will show the current ramping value. However, it will revert to show the set point value as soon as the up or down key is touched for adjustment. The ramp rate is initiated at power on and/or whenever the Set point is changed. Setting the “RR” setting to zero means no ramping function is used.

### 3.5 User Calibration - Display Offset







Each unit is calibrated in the factory before shipment. The user can still modify the calibration in the field.

The basic calibration of the controller is highly stable and set for life. User calibration allows the user to offset the permanent factory calibration in order to:

- Calibrate the controller to meet a user reference standard.
- Match the calibration of the controller to that of a particular transducer or sensor input.
- Calibrate the controller to suit the characteristics of a particular installation.
- Remove long term drift in the factory set calibration.

There are two parameters: Offset Low (OFTL) and Offset High (OFTH) for adjustment to correct an error in the process value.

There are two parameters for the sensor input. These two signal values are CALO and CAHI. The input signal low and high values are to be entered in the CALO and CAHI parameters respectively.

Refer to page 3 for key operation and page 10 for the operation flowchart. Press and hold the  key until the setup Menu page is obtained. Then, press and release the  key to navigate to the calibration low parameter OFTL. Send your low signal to the sensor input of the controller, then press and release the  key. If the process value (the upper display) is different from the input signal, the user can use  and  keys to change the OFTL value (the lower display) until the process value is equal to the value the user needs. Press and hold the  key for 5 seconds to complete the low point calibration (the display should blink once). The same procedure is applied for high scale calibration.

As shown below, the two points OFTL and OFTH construct a straight line. For the purpose of accuracy, it is best to calibrate with the two points as far apart as possible. After the user calibration is complete, the input type will be stored in the memory. If the input type is changed, a calibration error will occur and an error code `ERR` is displayed.

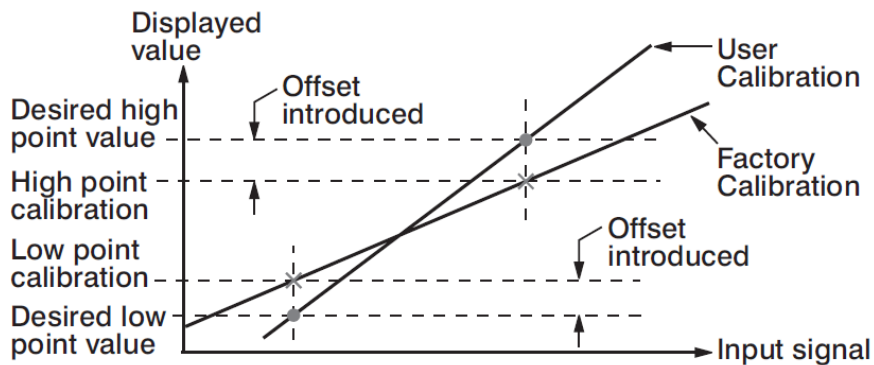

**3-3. Two Point User Calibration**

## 3.6 Digital Filter

In certain applications the process value is too unstable to be read. To improve this, a programmable low pass filter incorporated in the controller can be used. This is a first order filter with a time constant specified by the FILT parameter. A value of 0.5 seconds is used as a factory default. Adjust FILT to change the time constant from 0 to 60 seconds. 0 seconds represents no filter applied to the input signal. The filter is characterized by the following diagram.

**Note:** The Filter is available only for the process value (PV), and is performed for the displayed value only. The controller is designed to use an unfiltered signal for control even when a filter is applied. If a lagged (filtered) signal is used for control; it may produce an unstable process.

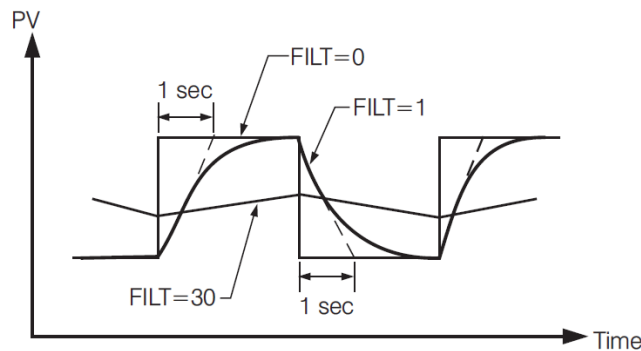

**3-4. Filter Characteristics**

## 3.7 Failure Transfer

The controller will enter failure mode if one of the following conditions occurs:

1. An SBER error occurs due to an input sensor break, an input current below 1mA for 4-20mA, or an input voltage below 0.25V for 1-5 V.
2. An ADER error occurs due to the A-D converter failing.

Output 1 and Output 2 will perform the failure transfer (O1.ft & O2.ft) function as the controller enters failure mode.

### 3.7.1 Output 1 Failure Transfer

If Output 1 Failure Transfer is activated, it will perform as follows:

1. If output 1 is configured as proportional control ( $PB \neq 0$ ), and BPLS is selected for O1FT, then output 1 will perform a Bumpless transfer. After that, the previous average value of the output will be used for controlling output 1.
2. If output 1 is configured as proportional control ( $PB \neq 0$ ), and a value of 0 to 100.0 % is set for O1FT, then output 1 will perform failure transfer. After that the value of O1FT will be used for controlling output 1.
3. If output 1 is configured as ON-OFF control ( $PB = 0$ ), then output 1 will transfer to an off state if OFF is set for O1FT, or it will transfer to an on state if ON is set for O1FT.





## 3.8 Auto-Tuning

 The Auto-Tuning process will be performed at the set point (SP1). The process will oscillate around the set point during the tuning process. Set a set point to a lower value if overshooting beyond the normal process value will cause damage. It is usually best to perform Auto-Tuning at the Set point the machine is expected to be operated at, with the process running normally (i.e. material in the oven, etc.).

Auto-Tuning is generally applied in the following cases:

- Initial setup for a new process.
- The set point is changed substantially from the previous Set point when Auto-Tuning was performed.
- The control result is unsatisfactory.

### 3.8.1 Auto-Tuning Operation Steps

1. The system is set up to run under real-world conditions.
2. “PB and “TI” settings should not be set to zero.
3. The LOCK parameter should be set to NONE.
4. Set the set point to a normal operating value, or a lower value if overshooting beyond the normal process value will cause damage.
5. Press and hold the  key until  appears on the upper display. Continue to hold the “” key for an additional 3 seconds, else the display will revert to a “User Menu” parameter.
6. Press and hold the  key until the TUNE indicator begins to flash.
7. The Auto-Tuning process has begun.

**NOTE:** During Auto-Tuning, the output will stay on until the Process Value reaches the setpoint. This is likely to cause the temperature to exceed the setpoint.

Then, the output will remain off until the process value falls below the setpoint.

This will occur at least two times while the controller “learns” how to control your process.

#### Procedures:



Auto-Tuning can be applied either as the process is warming up (Cold Start) or as the process has been in steady state (Warm Start). After the Auto-Tuning process is completed, the TUNE indicator will stop flashing and the unit will revert to PID control by using its new PID values. The PID values obtained are stored in nonvolatile memory.

### 3.8.2 Auto-Tuning Error

If Auto-Tuning fails, an ATER  message will appear on the upper display in any of the following cases.

- If PB exceeds 9000 ( 9000 PU, 900.0°F or 500.0°C )
- If TI exceeds 1000 seconds
- If the set point is changed during the Auto-Tuning process

### 3.8.3 Solution for an Auto-Tuning Error

1. Try Auto-Tuning once again.
2. Avoid changing the set point value during the Auto-Tuning process.
3. Ensure PB and TI are not set to zero.
4. Use manual tuning.
5. Touch RESET  key to reset the  message.

### 3.9 Manual Tuning

In certain applications, using Auto-Tuning may be inadequate for the control requirement, or, the process moves too slowly to Auto-tune accurately.

If this is the case, the user can try manual tuning.

If the control performance by using Auto-Tuning is still unsatisfactory, the following guidelines can be applied for further adjustment of PID values.

ADJUSTMENT SEQUENCE	SYMPTOM	SOLUTION
Proportional Band ( PB )	Slow Response	Decrease PB
	High overshoot or Oscillations	Increase PB
Integral Time ( TI )	Slow Response	Decrease TI
	Instability or Oscillations	Increase TI
Derivative Time ( TD )	Slow Response or Oscillations	Decrease TD
	High Overshoot	Increase TD



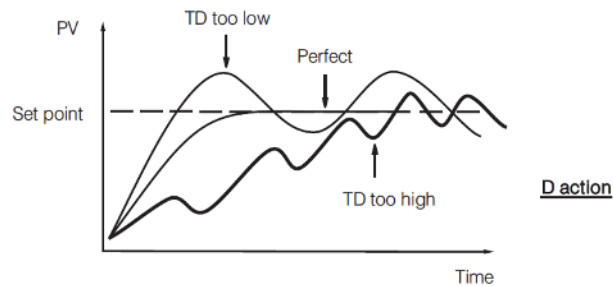
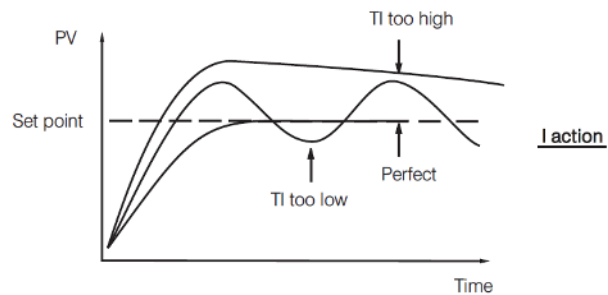
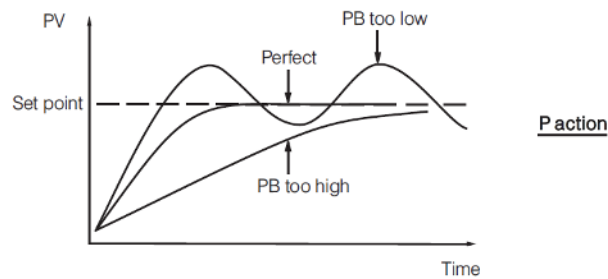

#### 3-2. PID Parameter Adjustment Guide





#### 3-5. Effects of PID Adjustment

## 3.10 Manual Control

To enable manual control, ensure the LOCK parameter is set to NONE.

Press and hold  until  (Hand Control) appears on the display. Press and hold  until the “MANU” indicator begins to flash. The lower display will show .

 Indicates the output control variable for output 1, and  indicates the control variable for output 2. The user can use the up-down keys to adjust the percentage values for the heating or cooling output. This % value is based on the CYC1 and CYC2 settings, where the associated output will stay on for the % of time the CYC1 & CYC2 values are set for.

Example: If CYC1 is set to 20 seconds, and the controller is set to “H50.0”, the output will be on for 10 seconds, then turn off for 10 seconds.





The controller performs open loop control and ignores the input sensor as long as it stays in manual control mode.

### 3.10.1 Exit Manual Control

Pressing the  key will revert the controller to its normal display mode.

## 3.11 Setting Controller to Factory Default

The controller’s parameters can be loaded with default values listed in the parameter description table. In certain situations it is desirable to retain these values after the parameters values has been changed. The below procedure to be followed to reload the default values.

1. Ensure the LOCK parameter is set to NONE.
2. Press and hold  until  (Hand Control) appears on the display.
3. Press and release the  key to cycle through the manual mode menu to reach “FILE”.
4. Press and hold  for 5 seconds or until the upper display FILE flash for a moment.

## 4 ERROR CODES

The description of the Error code is explained below:

Error Code	Display Symbol	Description & Reason	Corrective Action
4	ER04	<b>Illegal setup values used:</b> COOL is used for OUT2 when DIRT (cooling action) is used for OUT1, or when PID mode is not used for OUT1 (PB=0 and/or TI=0)	Check and correct setup values of OUT2, PB1, PB2, T11, TI2 and OUT1. IF OUT2 is needed for cooling control, the controller should use PID mode (PB≠0 and TI≠0) and OUT1 should use reverse mode (heating action), otherwise, OUT2 cannot be used for cooling control.
10	ER10	<b>Communication error:</b> bad function code	Correct the communication software to meet the protocol requirements.
11	ER11	<b>Communication error:</b> register address out of range	Do not issue an over-range address of the register to the secondary.
14	ER14	<b>Communication error:</b> attempt to write a read-only data	Do not write read-only data or protected data to the secondary.
15	ER15	<b>Communication error:</b> write a value which is out of range to a register	Do not write an over-range data to the secondary register.
16	EIER	<b>Event Input Error:</b> Two or more event inputs are set to the same function	Do not set the same function in two or more Event Input Function parameters (E1FN through E6FN).
26	ATER	<b>Auto-Tuning Error:</b> Failed to perform Auto-Tuning function	<ol style="list-style-type: none"> <li>1. The PID values obtained after Auto-Tuning process are out of range. Retry Auto-Tuning.</li> <li>2. Do not change the set point value during Auto-Tuning process.</li> <li>3. Use manual tuning instead of Auto-Tuning process.</li> <li>4. Do not set a zero value for TI.</li> <li>5. Do not set a zero value for PB.</li> <li>6. Touch RESET key.</li> </ol>
29	EEPR	EEPROM can't be written correctly	Cannot repair.
30	CJER	Cold junction compensation for Thermocouple malfunction	Cannot repair.
39	SBER	Input sensor break, or input current below 1 mA if 4-20 mA is used, or input voltage below 0.25V if 1 - 5V is used	Replace the input sensor.
40	ADER	A to D converter or related component(s) malfunction	Cannot repair.

# NOTES

# NOTES

## **RETURNS**

No product returns can be accepted without a completed Return Material Authorization (RMA) form.

## **TECHNICAL SUPPORT**

Technical questions and troubleshooting help is available from Tempco. When calling or writing please give as much background information on the application or process as possible.

E-mail: [techsupport@tempco.com](mailto:techsupport@tempco.com)

Phone: 630-350-2252

800-323-6859

**Note:** Information in this manual was deemed correct at the time of printing. The policy of Tempco is one of continuous development and product improvement, and we reserve the right to modify specifications and designs without prior notice. Not responsible for typographical errors.

# Custom Manufacturer Since 1972

ELECTRIC HEATING ELEMENTS • TEMPERATURE CONTROLS • SENSORS • PROCESS HEATING SYSTEMS

---

## HEAT THINGS UP!

With Thousands of Design Variations  
We Make Everything You Need.

Band Heaters  
Cast-In Heaters  
Radiant Heaters  
Flexible Heaters  
Process Heaters  
Temperature Control

Cartridge Heaters  
Coil & Cable Heaters  
Strip Heaters  
Tubular Heaters  
Instrumentation  
Temperature Sensors

---



607 N. Central Avenue Wood Dale, IL 60191-1452 USA  
P: 630-350-2252 Toll Free: 800-323-6859  
F: 630-350-0232 E: info@tempco.com  
[www.tempco.com](http://www.tempco.com)