

USER INSTRUCTIONS

Intelligent 2-wire In-head Temperature Transmitter

IPAQ-H/HX



The user instruction must be read prior to adjustment and/or installation.
All information subject to change without notice.

MEASURE OF SUCCESS



INOR

INOR Process AB, PO Box 9125, SE-200 39 Malmö, Sweden,
Phone: +46-40-31 25 60, Fax: +46-40-31 25 70, E-mail: support@inor.se

INOR Transmitter OY, Unikkotie 13, FI-01300 Vantaa, Finland,
Phone: +358-10-421 7900, Fax: +358-10-421 7901, E-mail: support.fi@inor.se

INOR Transmitter GmbH, Am Bocksborn 5,
D-63571 Gelnhäusen, Germany,
Phone: +49-6051 14807, Fax: +49-6051 14806, E-mail: support.de@inor.se

KROHNE Temperature Division INOR, 7 Dearborn Road,
Peabody, MA 01960, USA,
Phone: +1-978-826 6900, Fax: +1-978-535 3882, E-mail: inor-info@krohne.com

www.inor.com, www.inor.se



This product should not be mixed with other kind of scrap, after usage.
It should be handled as an electronic/electric device.

MEASURE OF SUCCESS

INTRODUCTION

IPAQ-H is a universal and intelligent 2-wire In-head transmitter for temperature and other measurement applications in industrial environment.

IPAQ-HX is the Intrinsic Safe version for use in Ex-applications.

GENERAL INFORMATION

The transmitter is configured from a standard IBM compatible PC by using the IPRO software version 4.14 or later. The latest version of IPRO can be downloaded from <http://www.inor.com>. When the transmitter is set from a PC no calibration is needed.

! The transmitter must not be connected to a computer, when the transmitter is in hazardous area.

The transmitter is polarity protected and will not be damaged by connecting the power supply with the wrong polarity, but the output will be 0 mA.

The maximum load in the output loop depends on the supply voltage, see "DATA shortform"

The transmitter continuously supervises the isolation resistance in thermocouples and 3-wire-connected Pt100 including the connection wires. If the isolation resistance is low it causes error in the measurements and consequently a faulty output. The transmitter indicates low isolation resistance by forcing the output to a preprogrammed value. This function requires setting by the PC-program IPRO and the use of a temperature sensor with an extra wire.

Sensor wire check: the transmitter uses a pulsating technique to monitor sensor break or sensor shortened to avoid measuring errors. This pulsating signal may interfere with some electronic calibrators. By selecting "Sensor Break = None" in the IPRO software and download the configuration into the transmitter the pulsating signal is turned off.

DIMENSIONS

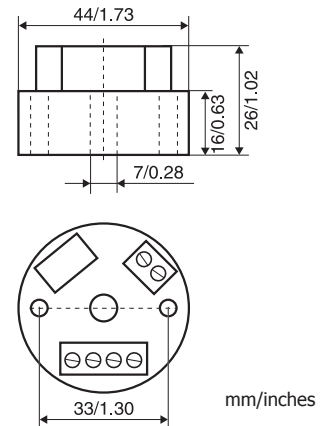

CONFIGURATION

The IPAQ-H/HX transmitter must be powered, when you configure the transmitter, (see "Connections" fig.1). If IPRO (the IPAQ software) isn't installed in your PC, install the software (follow the instructions in "IPRO User instructions").

! For keeping the safety of the internal circuits in the IPAQ-HX, always use Ex-power supply or a zener barrier with limitations according to Ex-data and IPRO-X configuration cable when making a configuration of the transmitter.

When choosing differential temperature measurements with Pt100 be sure to select "sensor break" = none. Configuration from PC is "on-line", that is, the transmitter can be configured while in operation if the area is known to be non-hazardous. The output is frozen while transmission from PC to IPAQ take place. When transfer is done the transmitter uses the new parameters.

DATA (shortform)

Power supply:	IPAQ-H	6.5 to 36 VDC
	IPAQ-HX	8 to 30 VDC
Isolation in/out:		1500 VAC
Output:		4-20 mA
Operating temperature:		-40 to +50 °C (T6)
		-40 to +65 °C (T5)
		-40 to +85 °C (T4)

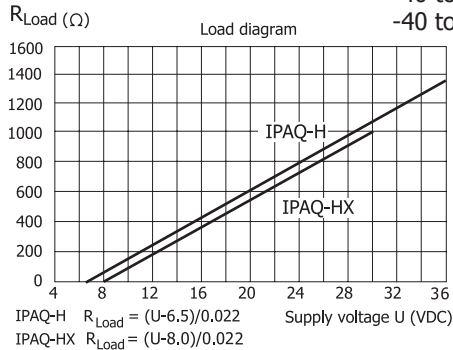

IPAQ-HX EX-DATA

Approval Demko 02 ATEX 132033X

CE 0539 II 1G Ex ia IIC T4-T6

Approval FM, J.I 0D6A8.AX, CSA 2007 Certificate 1863602

Class I, Division 1, Group A, B, C and D

Control Drawing 3-7851

Output (current loop)

U_i	≤ 30 VDC
I_i	≤ 100 mA
P_i	≤ 900 mW
L_i	~ 0 mH
C_i	~ 0 nF

Input (sensor)

U_o	≤ 30 VDC
I_o	≤ 25 mA
P_o	≤ 188 mW
L_o	~ 50 mH
C_o	~ 66 nF

IPAQ-HX must be powered from an intrinsic safe power supply or zener barrier, placed outside the hazardous area.
Also see Control Drawing 88DRW00023.

CONNECTIONS

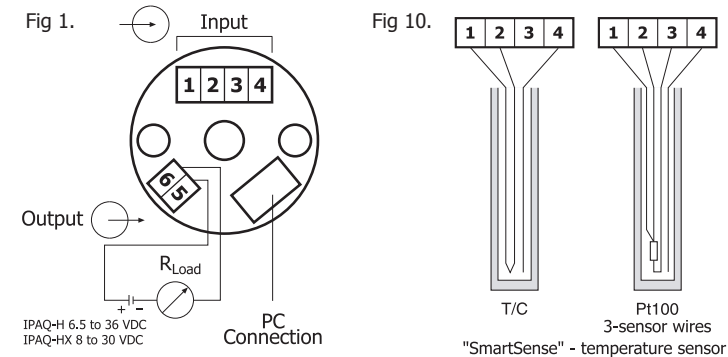

LIMITED WARRANTY

INOR Process AB, or any other affiliated company within the Inor Group (hereinafter jointly referred to as "Inor"), hereby warrants that the Product will be free from defects in materials or workmanship for a period of five (5) years from the date of delivery ("Limited Warranty"). This Limited Warranty is limited to repair or replacement at Inor's option and is effective only for the first end-user of the Product. Upon receipt of a warranty claim, Inor shall respond within a reasonable time period as to its decision concerning:

- Whether Inor acknowledges its responsibility for any asserted defect in materials or workmanship; and, if so,
- the appropriate cause of action to be taken (i.e. whether a defective product should be replaced or repaired by Inor).

This Limited Warranty applies only if the Product:

- is installed according to the instructions furnished by Inor;
- is connected to a proper power supply;
- is not misused or abused; and
- there is no evidence of tampering, mishandling, neglect, accident damage, modification or repair without the approval of Inor or damage done to the Product by anyone other than Inor.

This Limited Warranty is provided by Inor and contains the only express warranty provided. **INOR SPECIFICALLY DISCLAIMS ANY EXPRESS WARRANTY NOT PROVIDED HEREIN AND ANY IMPLIED WARRANTY, GUARANTEE OR REPRESENTATION AS TO SUITABILITY FOR ANY PARTICULAR PURPOSE, PERFORMANCE, QUALITY AND ABSENCE OF ANY HIDDEN DEFECTS, AND ANY REMEDY FOR BREACH OF CONTRACT, WHICH BUT FOR THIS PROVISION, MIGHT ARISE BY IMPLICATION, OPERATION OF LAW, CUSTOM OF TRADE OR COURSE OF DEALING, INCLUDING IMPLIED WARRANTIES OF MERCHANTABILITY AND FITNESS FOR A PARTICULAR PURPOSE. EXCEPT AS PROVIDED HEREIN, INOR FURTHER DISCLAIMS ANY RESPONSIBILITY FOR LOSSES, EXPENSES, INCONVENIENCES, SPECIAL, DIRECT, SECONDARY OR CONSEQUENTIAL DAMAGES ARISING FROM OWNERSHIP OR USE OF THE PRODUCT.**

Products that are covered by the Limited Warranty will either be repaired or replaced at the option of Inor. Customer pays freight to Inor, and Inor will pay the return freight by post or other "normal" way of transport. If any other type of return freight is requested, customer pays the whole return cost.

INSTALLATION

IPAQ-H/HX are designed to fit inside connection heads type DIN B or larger.

The larger center hole, dia. 7 mm/0.28 inch (see "Dimensions"), facilitates the pulling through of the sensor leads or an insert tube, greatly simplifying the mounting procedure.

IPAQ-HX must be installed in an enclosure having an Ingress Protection suitable for the actual use but at least IP20.

If IPAQ-HX is mounted in a housing (head) made of light metals and installed in hazardous area make sure the content of magnesium (Mg) in the light metal is less than 6%.

If IPAQ-HX is mounted in a housing which is isolated from ground and can be charged to an ignition capable level, then the housing shall be electrostatically grounded when installed in hazardous area.

Connect input, output and power supply acc. to fig. 1-9.

A convenient way to install the transmitter is to use the INOR mounting kits for in-head and DIN rail mounting, (see "Ordering table"). In order to minimize measuring errors make sure the connecting screws are tightened enough.

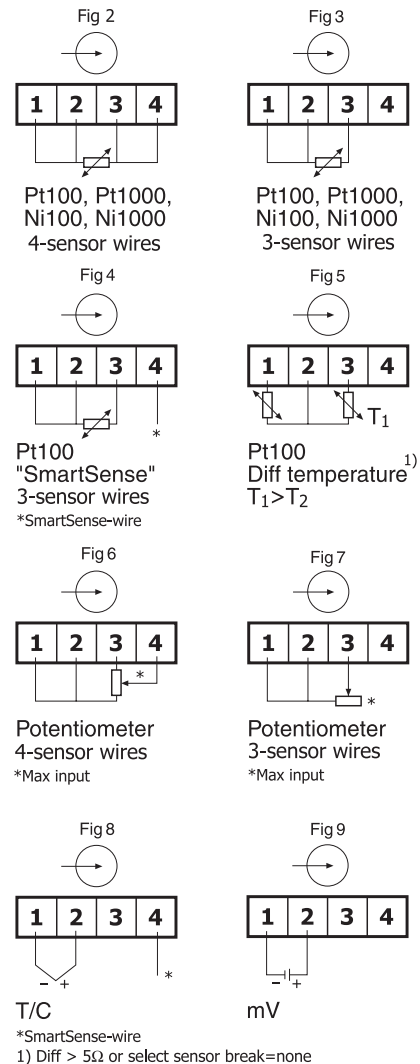

ORDERING TABLE

Item	Part No.
IPAQ-H, isolated	70IPH00001
IPAQ-HX, isolated (ATEX)	70IPHX0001
IPAQ-HX, isolated (FM, CSA)	70IPHX1001
Software and cable	
Configuration kit IPRO with cables	70CFG00092
Accessories	
Surface mounting box	70ADA00008
Rail mounting box	70ADA00009
Head mounting kit	70ADA00012
Rail mounting kit	70ADA00013