



IPAQ C330/R330

Universal transmitter with NFC technology

The documentation is only complete when used in combination with the relevant documentation for the signal converter. The manual/handbook must be read prior to adjustment and/or installation. All information is subject to change without notice.

1	Safety instructions	5
1.1	Intended use	5
1.2	Certifications	6
1.2.1	EU directive compliance	6
1.2.2	Ex approvals	6
1.3	Safety instructions from the manufacturer	7
1.3.1	Copyright and data protection	7
1.3.2	Disclaimer	7
1.3.3	Product liability and warranty	8
1.3.4	Information concerning the documentation	8
1.3.5	Warnings and symbols used	9
1.4	Safety instructions for the operator	9
2	Device description	10
2.1	General description	10
2.2	Nameplate	11
2.3	Scope of delivery	13
3	Installation	14
3.1	In-head transmitter	14
3.2	Rail mounting kit for in-head transmitters	15
3.3	Rail-mount transmitter	16
4	Electrical connections	17
4.1	Safety instructions	17
4.2	Electrical connections of in-head transmitter	19
4.3	Connection diagram of in-head transmitter	20
4.4	Connection diagram of in-head transmitter (intrinsically safe)	20
4.5	Electrical connections of rail-mount transmitter	22
4.6	Connection diagram of rail-mount transmitter	23
4.7	Connection diagram of rail-mount transmitter (intrinsically safe)	23
5	Operation	24
5.1	NFC configuration and logging	24
5.2	Factory settings for configuration	25
5.3	Configuration with ConSoft	26
5.4	Diagnostic information according to NAMUR NE 107	29
5.5	Factory default settings	31
5.6	Sensor error monitoring	31
5.7	System or sensor error correction	31
6	Service	32

6.1	Accessory parts	32
6.2	Spare parts availability	32
6.3	Availability of services	32
6.4	Returning the device to the manufacturer	32
6.4.1	General information	32
6.4.2	Form (for copying) to accompany a returned device	33
6.5	Disposal	33
6.5.1	Dispose of the transmitter	33
6.5.2	Disassembling and recycling	34
6.5.3	Disassembling and recycling of IPAQ C330/C330X	34
6.5.4	Disassembling and recycling of IPAQ R330/R330X	35
6.5.5	Packaging of IPAQ C330/C330X and R330/R330X	37
7	Technical data	38
<hr/>		
7.1	Measuring principles	38
7.1.1	Resistance temperature sensor	38
7.1.2	Thermocouples	39
7.2	Technical data	40
7.3	Dimensions	45
7.4	Temperature data for areas with potentially explosive atmospheres	46
7.5	Output load diagram	47
7.6	Electrical data for outputs and inputs	48
7.7	RTD and T/C accuracy table	49
8	Appendix	51
<hr/>		
8.1	Installation and control drawings	51
9	Notes	56
<hr/>		

1.1 Intended use

The IPAQ 330 signal conditioner is a universal two-wire transmitter intended to be used in industrial environments and designed for:

- Temperature measurements with resistance thermometers
- Temperature measurements with thermocouples
- Voltage measurements in a range up to 1000 mV
- Resistance measurement up to 10 k Ω
- Measurements with potentiometers

C330 / C330X is intended for installation in a DIN B-head or larger according to EN 50446.

R330 / R330X is intended for installation on a 35 mm DIN-rail according to EN 60715/DIN 50022.

The transmitters are configured from a PC by using the ConSoft program and a transmitter configuration kit (USB connection), or by a smartphone with built-in NFC support. NFC applies only to later versions of, see table on page 10.



DANGER!

You may only use transmitters labelled with the "Ex" symbol in potentially explosive areas or connect them to a sensor located in those areas. Additionally always note the zone(s) for which the devices have an approval. Otherwise the transmitters might cause an explosion that can result in fatal injuries.



DANGER!

Responsibility for the correct use of the devices with special regard to suitability, intended use and the field of application lies solely with the operator. To avoid any kind of incorrect use, also note the information in the chapter "Device description".



DANGER!

The transmitters do not contain any serviceable parts inside. Any substitution of components may impair the intrinsic safety of the versions with an Ex approval. Always send defective devices to the manufacturer or the local distributor for repair or exchange. If this is the case, attach a clear description of the malfunction for warranty claims.



The manufacturer is not liable for any damage resulting from improper use or use for other than the intended purpose. To avoid any kind of incorrect use, also note the information in the chapter "Device description".



CAUTION!

Responsibility for the use of the measuring devices with regard to suitability, intended use and corrosion resistance of the used materials against the measured fluid lies solely with the operator.



This device is a Group 1, Class A device as specified within CISPR11. It is intended for use in industrial environment. There may be potential difficulties in ensuring electromagnetic compatibility in other environments, due to conducted as well as radiated disturbances.

1.2 Certifications

1.2.1 EU directive compliance

CE marking



The device fulfils all applicable statutory requirements of the following EU directives:

- EMC Directive 2014/30/EU, harmonized standards EN 61326-1 and EN 61326-2-3
- Devices for use in hazardous areas: ATEX Directive 2014/34/EU, harmonized standards EN 60079-0 and EN 60079-11
- CE Directive 93/68/EC
- RoHS Directive 2011/65/EU, harmonized standard EN 50581.
- Radio Equipment Directive (RED) 2014/53/EU.

The manufacturer certifies successful testing of the product by applying the CE marking.

1.2.2 Ex approvals

C330X (intrinsically safe), part no. 70C330X010 and 70C330X012

ATEX	KIWA 16ATEX0038 X	II 1 G Ex ia IIC T6...T4 Ga
IECEX	IECEX KIWA 16.0016X	Ex ia IIC T6...T4 Ga
USA	FM17US0283X	IS CL I DIV 1 GP A-D, T6...T4 Cl I Zn 0 AEx/Ex ia IIC T6...T4 Ga
Canada	FM17CA0144X	

R330X (intrinsically safe), part no. 70R330X010 and 70R330X012

ATEX	KIWA 16ATEX0040 X	II 1 G Ex ia IIC T6...T4 Ga
IECEX	IECEX KIWA 16.0018X	Ex ia IIC T6...T4 Ga
USA	FM17US0283X	IS CL I DIV 1 GP A-D, T6...T4 Cl I Zn 0 AEx/Ex ia IIC T6...T4 Ga
Canada	FM17CA0144X	



See also "Specific Conditions of Use" in the Ex certificates in the download area of the manufacturer's website

1.3 Safety instructions from the manufacturer

1.3.1 Copyright and data protection

The contents of this document have been created with great care. Nevertheless, we provide no guarantee that the contents are correct, complete or up-to-date.

The contents and works in this document are subject to copyright. Contributions from third parties are identified as such. Reproduction, processing, dissemination and any type of use beyond what is permitted under copyright requires written authorisation from the respective author and/or the manufacturer.

The manufacturer tries always to observe the copyrights of others, and to draw on works created in-house or works in the public domain.

The collection of personal data (such as names, street addresses or e-mail addresses) in the manufacturer's documents is always on a voluntary basis whenever possible. Whenever feasible, it is always possible to make use of the offerings and services without providing any personal data.

We draw your attention to the fact that data transmission over the Internet (e.g. when communicating by e-mail) may involve gaps in security. It is not possible to protect such data completely against access by third parties.

We hereby expressly prohibit the use of the contact data published as part of our duty to publish an imprint for the purpose of sending us any advertising or informational materials that we have not expressly requested.

1.3.2 Disclaimer

The manufacturer will not be liable for any damage of any kind by using its product, including, but not limited to direct, indirect or incidental and consequential damages.

This disclaimer does not apply in case the manufacturer has acted on purpose or with gross negligence. In the event any applicable law does not allow such limitations on implied warranties or the exclusion of limitation of certain damages, you may, if such law applies to you, not be subject to some or all of the above disclaimer, exclusions or limitations.

Any product purchased from the manufacturer is warranted in accordance with the relevant product documentation and our Terms and Conditions of Sale.

The manufacturer reserves the right to alter the content of its documents, including this disclaimer in any way, at any time, for any reason, without prior notification, and will not be liable in any way for possible consequences of such changes.

1.3.3 Product liability and warranty

The operator shall bear responsibility for the suitability of the device for the specific purpose. The manufacturer accepts no liability for the consequences of misuse by the operator. Improper installation or operation of the devices (systems) will cause the warranty to be void. The respective "Standard Terms and Conditions" which form the basis for the sales contract shall also apply.

1.3.4 Information concerning the documentation

To prevent any injury to the user or damage to the device it is essential that you read the information in this document and observe applicable national standards, safety requirements and accident prevention regulations.

If this document is not in your native language and if you have any problems understanding the text, we advise you to contact your local office for assistance. The manufacturer can not accept responsibility for any damage or injury caused by misunderstanding of the information in this document.

This document is provided to help you establish operating conditions, which will permit safe and efficient use of this device. Special considerations and precautions are also described in the document, which appear in the form of icons as shown below.

1.3.5 Warnings and symbols used

Safety warnings are indicated by the following symbols.



DANGER!

This warning refers to the immediate danger when working with electricity.



DANGER!

This warning refers to the immediate danger of burns caused by heat or hot surfaces.



DANGER!

This warning refers to the immediate danger when using this device in a hazardous atmosphere.



DANGER!

These warnings must be observed without fail. Even partial disregard of this warning can lead to serious health problems and even death.



WARNING!

Disregarding this safety warning, even if only in part, poses the risk of serious health problems. There is also the risk of damaging the device or parts of the operator's plant.



CAUTION!

Disregarding these instructions can result in damage to the device or to parts of the operator's plant.



These instructions contain important information for the handling of the device.



LEGAL NOTICE!

This note contains information on statutory directives and standards.



• **HANDLING**

This symbol designates all instructions for actions to be carried out by the operator in the specified sequence.

➔ **RESULT**

This symbol refers to all important consequences of the previous actions.

1.4 Safety instructions for the operator



WARNING!

*In general, devices from the manufacturer may only be installed, commissioned, operated and maintained by properly trained and authorized personnel.
This document is provided to help you establish operating conditions, which will permit safe and efficient use of this device.*

2.1 General description

The IPAQ 330 signal conditioner is a smart, digital 2-wire transmitter for temperature measurements and other measurement applications in an industrial environment. For further information about the possible measurements refer to *Intended use* on page 5.

Configuration of the transmitter is possible with:

- PC configuration software ConSoft with PC configuration kit ICON-X.
- NFC interface in a portable device such as a smartphone. NFC applies only to later versions of IPAQ 330, see table below. The smartphone app - INOR Connect, makes it possible to read, write, save and share settings directly in the field.

The PC configuration software ConSoft is used for configuration, display and documentation. The current ConSoft version is available for downloading on our website. You can find configuration instructions in the ConSoft reference manual. ConSoft is compatible with Windows XP/Vista/7/8/8.1/10.

Different versions of the IPAQ 330

IPAQ	Part Number	NFC
C330 / C330X	70C3300010 / 70C330X010	No
	70C3300012 / 70C330X012	Yes
R330 / R330X	70R3300010 / 70R330X010	No
	70R3300012 / 70R330X012	Yes

IPAQ C330 - In-head transmitter

The IPAQ C330 is a smart, digital 2-wire universal in-head transmitter for temperature measurements and other measurement applications in an industrial environment. For further information about the possible measurements refer to *Intended use* on page 5.

The in-head transmitter is optionally available in an intrinsically safe version for installation in potentially explosive areas. These devices wear the "Ex" symbol and have an approval for mounting into classified hazardous area, Zone 0, 1 and 2 / DIV 1 and 2.

All in-head versions are intended for installation in a DIN B-head or larger according to EN 50446 / DIN 43729. As an alternative you can also mount the in-head version on a 35 mm rail according to EN 60715 / DIN 50022 with the help of the rail installation kit (refer to *Rail mounting kit for in-head transmitters* on page 15).

IPAQ R330 - Rail-mount transmitter

The IPAQ R330 rail-mount transmitter has the same features as the in-head version.

The rail-mount transmitter is optionally available in an intrinsically safe version for installation into potentially explosive areas. All devices with an Ex approval wear the "Ex" symbol. The rail-mount transmitter is intended for installation on a 35 mm rail according to EN 60715 / DIN 50022.

2.2 Nameplate



Look at the device nameplate to ensure that the device is delivered according to your order.

The transmitter can be identified by the information on the nameplates. For the different versions of IPAQ 330 refer to *NFC configuration and logging* on page 24.

Nameplate for in-head transmitter - Part no. 70C330X010

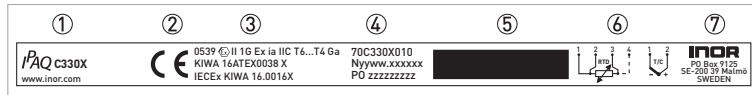

Figure 2-1: Example for round nameplate

- ① Product name
- ② CE marking (EC conformity)
- ③ Ex-relevant electrical data and Ex approvals
- ④ Part number, serial number (yyww = year and week of manufacturing) and batch number
- ⑤ Printable field, sensor configuration
- ⑥ Connections
- ⑦ Manufacturer and address

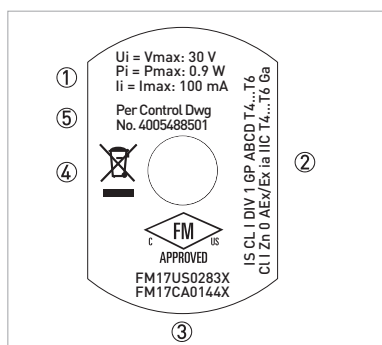

Figure 2-2: Example for bottom nameplate - Part no. 70C330X010

- ① Electrical data for output
- ② Ex-relevant electrical data
- ③ Ex approvals - North America
- ④ Electronic/electric device waste marking
- ⑤ Control drawing number

Nameplate for in-head transmitter - Part no. 70C330X012

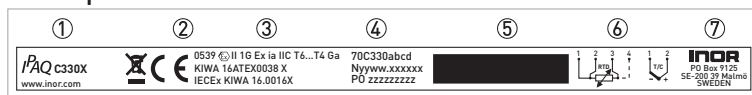

Figure 2-3: Example for round nameplate

- ① Product name
- ② CE marking (EC conformity) and electric/electronic device waste marking
- ③ Ex-relevant electrical data and Ex approvals
- ④ Part number, serial number (yyww = year and week of manufacturing) and batch number
- ⑤ Printable field, sensor configuration
- ⑥ Connections
- ⑦ Manufacturer and address

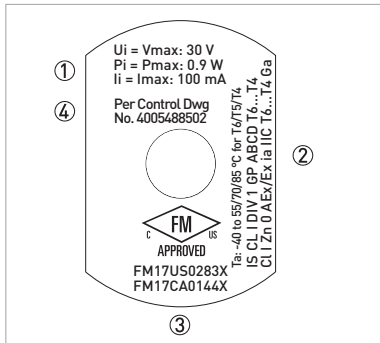

Figure 2-4: Example for bottom nameplate - Part no. 70C330X012

- ① Electrical data for output
- ② Ex-relevant electrical data
- ③ Ex approvals - North America
- ④ Control drawing number

Nameplate for rail-mount transmitter - Part no. 70R330X010

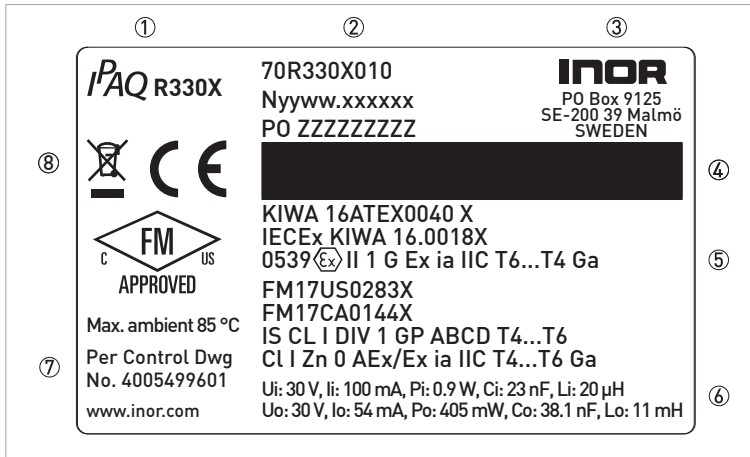

Figure 2-5: Example for nameplate

- ① Product name
- ② Part number, serial number (yyww = year and week of manufacturing) and batch number
- ③ Manufacturer and address
- ④ Printable field, sensor configuration
- ⑤ Ex-relevant electrical data and Ex approvals
- ⑥ Electrical data for output and input
- ⑦ Control drawing number
- ⑧ CE marking (EC conformity) and electronic/electric device waste marking

Nameplate for rail-mount transmitter- Part no. 70R330X012

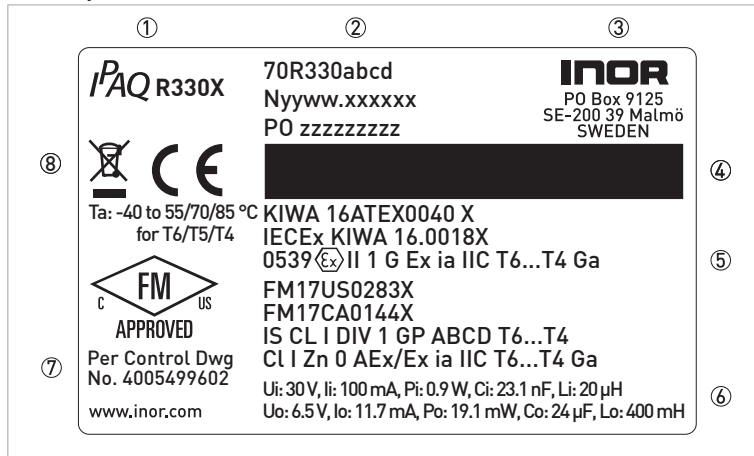

Figure 2-6: Example for nameplate

- ① Product name
- ② Part number, serial number (yyww = year and week of manufacturing) and batch number
- ③ Manufacturer and address
- ④ Printable field, sensor configuration
- ⑤ Ex-relevant electrical data and Ex approvals
- ⑥ Electrical data for output and input
- ⑦ Control drawing number
- ⑧ CE marking (EC conformity) and electronic/electric device waste marking

2.3 Scope of delivery



Inspect the packaging carefully for damages or signs of rough handling. Report damage to the carrier and to the local office of the manufacturer.



Do a check of the packing list to make sure that you have all the elements given in the order.



Look at the device nameplate to ensure that the device is delivered according to your order.

The scope of delivery always consists of the transmitter and its documentation.

3.1 In-head transmitter



DANGER!

IPAQ C330X must be installed in an enclosure having an Ingress Protection suitable for the actual use but at least IP20.

The transmitter is intended for installation in DIN B connection head or larger. For detailed information refer to *Dimensions* on page 45.

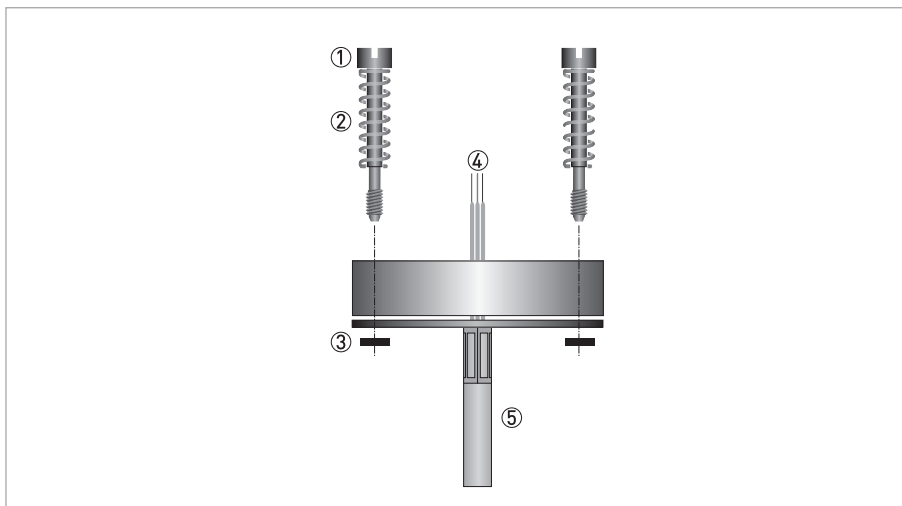

Figure 3-1: Connection head installation kit

- ① M4 screw
- ② Spring
- ③ Lock washer
- ④ Wires from the measuring insert.
- ⑤ MI cable



The connection head installation kit does not belong to the standard scope of delivery of the transmitter, you have to order it separately.



DANGER!

The transmitter is optionally available in an intrinsically safe version (zone 0, 1 and 2 / DIV 1 and 2) for installation in potentially explosive atmospheres. The intrinsically safe version must be supplied by an intrinsically safe power supply unit or Zener barrier placed outside of the potentially explosive zone.



WARNING!

The transmitter has been developed for an operating temperature of $-40...+85^{\circ}\text{C}$ / $-40...+185^{\circ}\text{F}$. To avoid destruction or damage of the device, always assure that the operating temperature or ambient temperature does not exceed the permissible range. The thermowell also transfer the process temperature to the transmitter housing. If the process temperature is close to or exceeds the maximum temperature of the transmitter, then the temperature in the transmitter housing can rise above the maximum permissible temperature. One way to decrease the heat transfer via thermowell is to install the transmitter further away from the heat source. Inversely similar measurements can be done if the temperature gets below specified minimum temperature.

3.2 Rail mounting kit for in-head transmitters



The rail mounting kit allows to install the in-head transmitter on a rail according to EN 60715 / DIN 50022.

The kit does not belong to the standard scope of delivery. You have to order it separately.

The screws in the kit is not to be used with this transmitter.

Rail mounting kit for in-head transmitters

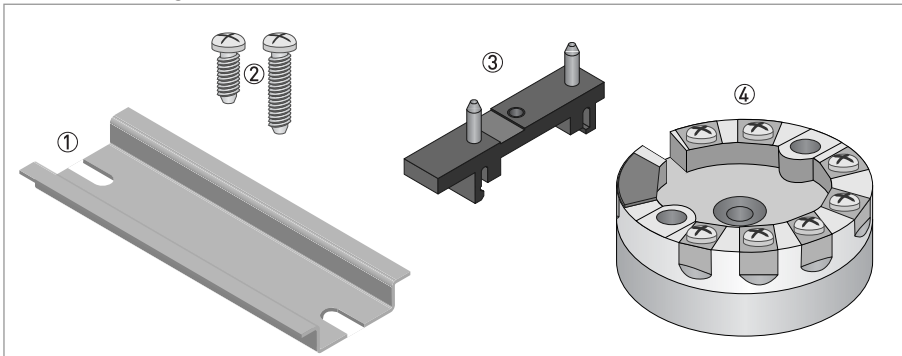
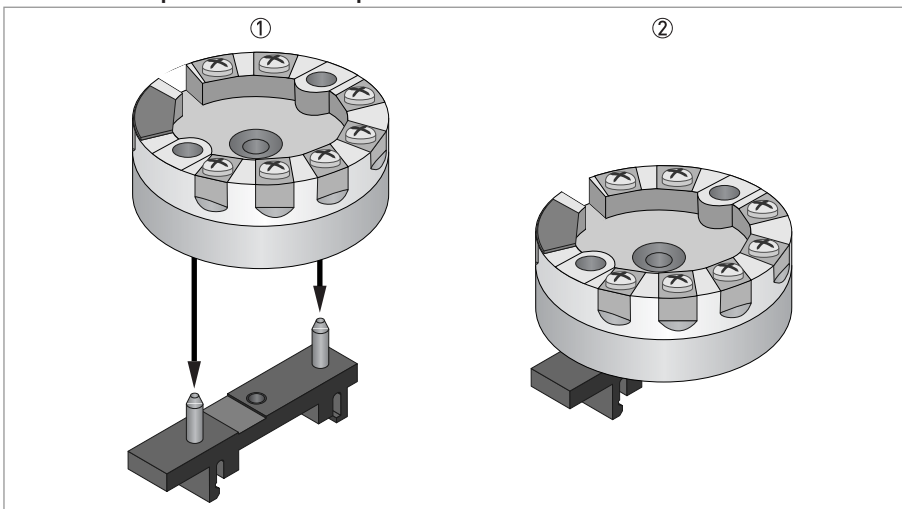

Figure 3-2: Rail mounting kit for in-head transmitters

- ① Rail (not included in the kit)
- ② Screws (not needed)
- ③ Clip
- ④ Transmitter

Installation procedure: Step 1



- ① Place the transmitter on the clip.
- ② Press down the transmitter until it is attached to the clip.

Installation procedure: Step 2

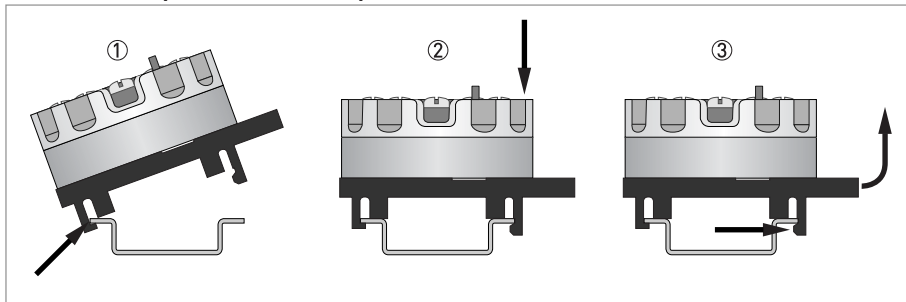

- ① Hook one end of the clip into the rail.
- ② Push the other end down until it snaps onto the rail.
- ③ Release by pushing the hook, and at the same time lift the clip out of the rail.

3.3 Rail-mount transmitter

**DANGER!**

IPAQ R330X must be installed in an enclosure having an ingress protection suitable for the actual use but at least IP20.

These transmitters are intended for installation on a 35 mm rail according to EN 60715 / DIN 50022.

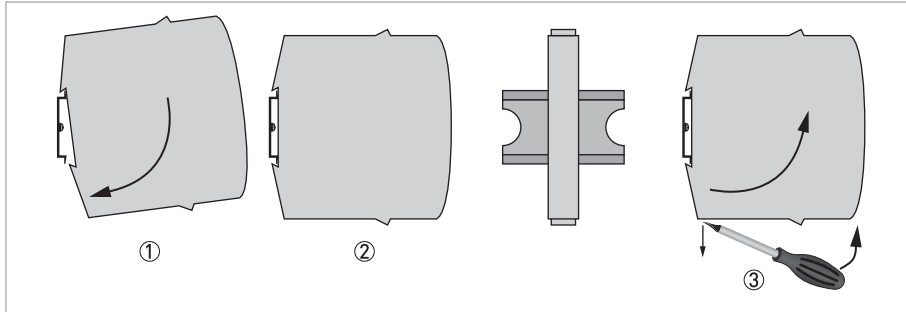

- ① Fix the upper part of the transmitter onto the rail.
- ② Press the lower part of the transmitter against the rail.
- ③ To remove the transmitter, bend the locking device using a small screwdriver. Carefully pull the transmitter in the forward direction.

**CAUTION!**

The manufacturer has developed the R330 for an operating temperature range of -40...+85°C / -40...+185°F.

To avoid destruction or damage of the device, always note the following items:

- *Assure that the operating temperature or the ambient temperature does not exceed the permissible range.*

4.1 Safety instructions



DANGER!

All work on the electrical connections may only be carried out with the power disconnected.
Take note of the voltage data on the nameplate!



DANGER!

Observe the national regulations for electrical installations!



The transmitter is protected against polarity reversal. No damage will occur to the device if the polarity of the supply voltage is switched. The output will then indicate 0 mA.



DANGER!

In potentially explosive areas, the intrinsically safe versions must be used.

The C330X / R330X (intrinsically safe) can be installed in potentially hazardous area zone 0, 1 and 2 / DIV 1 and 2.

The C330X / R330X (intrinsically safe) can be installed in potentially hazardous zone 0, 1 and 2 / DIV 1 and 2 and the input may be connected to temperature sensors installed in zone 0 / DIV 1.

The intrinsically safe versions must be supplied by an intrinsically safe power supply unit or Zener barrier placed outside of the potentially explosive area.



DANGER!

Never connect or operate a non-Ex version of a transmitter in potentially explosive areas, otherwise it might cause an explosion that can result in fatal injuries! Before you connect and operate a transmitter version with an Ex approval, always note the following items to avoid an explosion which may result in fatal injuries

- Connect the Ex version only to Ex approved sensors or sensors that meet the requirements for "simple apparatus" in EN 60079-11.
- Observe the corresponding regulations, the declaration of conformity, the Ex type test certificate of the device and the relevant instructions of this document.
- The intrinsically safe versions must be supplied by an intrinsically safe power supply unit or a Zener barrier placed outside of the potentially explosive area.



WARNING!

Observe without fail the local occupational health and safety regulations.

Any work done on the electrical components of the measuring device may only be carried out by properly trained specialists.



Look at the device nameplate to ensure that the device is delivered according to your order. Check for the correct supply voltage printed on the nameplate (applies only to the intrinsically safe versions).

***DANGER!***

For the transmitters used in hazardous areas following special conditions have to be considered: The communication interface (USB connection) may only be connected to the associated ICON interface if the temperature transmitter is outside of the hazardous area. If certified ICON-X interface is used, a connected sensor may be located in the hazardous area. If non-Ex ICON interface is used, a connected sensor shall not be located in the hazardous area. For the permitted ambient temperature range, refer to Temperature data for areas with potentially explosive atmospheres on page 46. The transmitter shall be mounted into a suitable enclosure that provides a degree of protection of at least IP20. The NFC Interface for communication must not be used in hazardous areas.

4.2 Electrical connections of in-head transmitter

The input and output signals and the power supply must be connected in accordance with the following illustrations. The transmitter is easy to install with the connection head installation kit. To avoid measuring errors, all cables must be connected properly and the screws tightened correctly.

RTD and potentiometer measurement

Pt100...Pt1000, Ni100, Ni120, Cu10 2-wire connection	Pt100...Pt1000, Ni100, Ni120, Cu10 3-wire connection	Pt100...Pt1000, Ni100, Ni120, Cu10 4-wire connection
Resistance, 2-wire connection	Resistance, 3-wire connection	Resistance, 4-wire connection
Potentiometer, 3-wire slide wire		

Thermocouple and voltage measurement

Thermocouple	Voltage	Thermocouple with external CJC (Pt100)

4.3 Connection diagram of in-head transmitter



CAUTION!

Always establish the electrical connections according to the following diagrams. Otherwise it can come to destruction or damage of the transmitter. Note that the maximum output load always depends on the power supply. If the maximum output load is exceeded, then the measured value will become incorrect. For further information refer to Technical data on page 40.

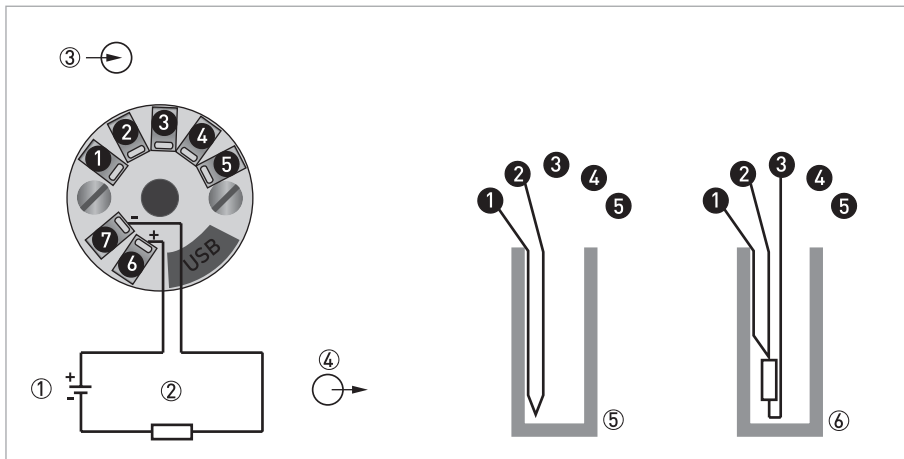

Figure 4-1: Connection diagram

- ① Voltage supply VDC (terminals 6, 7)
- ② R_{Load}
- ③ Input
- ④ Output
- ⑤ Pt100 3-wire connection

4.4 Connection diagram of in-head transmitter (intrinsically safe)

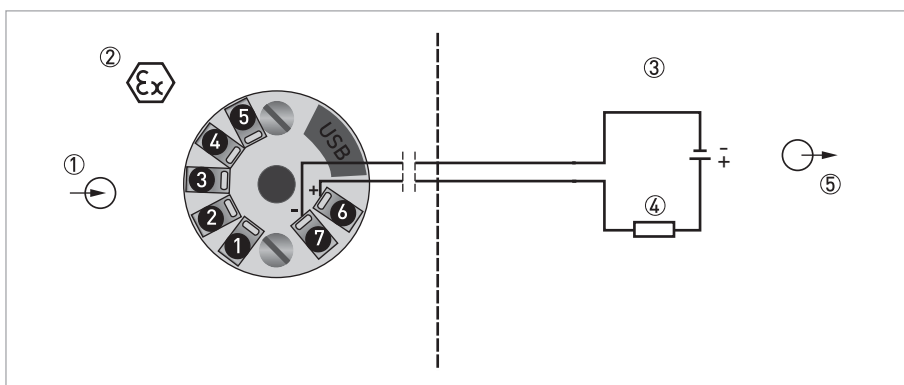

Figure 4-2: Connection diagram

- ① Input (intrinsically safe)
- ② Classified hazardous area (potentially explosive area e.g. zone 0, 1 and 2 / DIV 1 and 2)
- ③ Safe area
- ④ R_{Load} (intrinsically safe)
- ⑤ Zener barrier / Voltage supply 8.0...30 VDC (intrinsically safe) and output 4...20 mA

***DANGER!***

The transmitter may be operated in areas with potentially explosive atmospheres if the voltage supply is ensured by means of an associated apparatus.

4.5 Electrical connections of rail-mount transmitter

The input and output signals and the power supply must be connected in accordance with the following illustrations. To avoid measuring errors, all cables must be connected properly and the screws tightened correctly.

RTD and potentiometer measurement

Pt100...Pt1000, Ni100, Ni120, Cu10 2-wire connection	Pt100...Pt1000, Ni100, Ni120, Cu10 3-wire connection	Pt100...Pt1000, Ni100, Ni120, Cu10 4-wire connection
Resistance, 2-wire connection	Resistance, 3-wire connection	Resistance, 4-wire connection
Potentiometer, 3-wire slide wire		

Thermocouple and voltage measurement

Thermocouple	Voltage	Thermocouple with external CJC (Pt100)

4.6 Connection diagram of rail-mount transmitter

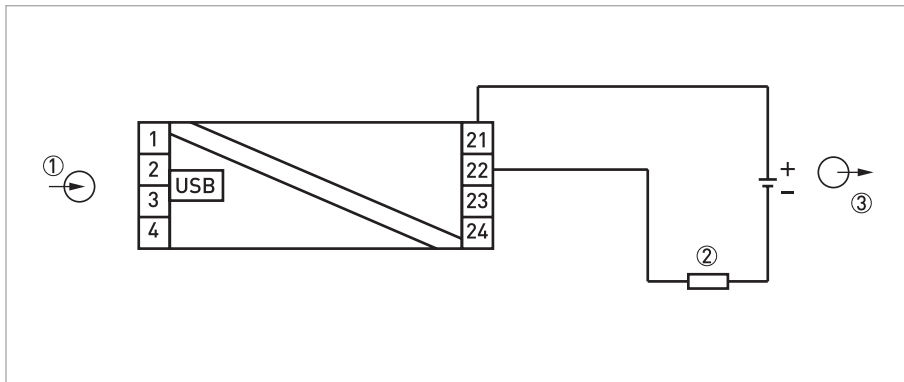

Figure 4-3: Connection diagram

- ① Input
- ② R_{Load}
- ③ Voltage supply 8...36 VDC and output 4...20 mA

4.7 Connection diagram of rail-mount transmitter (intrinsically safe)

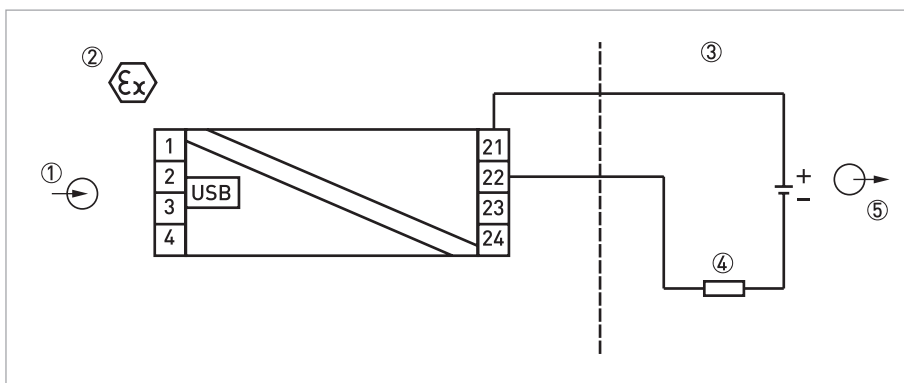

Figure 4-4: Connection diagram

- ① Input (intrinsically safe)
- ② Classified hazardous area (potentially explosive area e.g. zone 0, 1 and 2 / DIV 1 and 2)
- ③ Safe area
- ④ R_{Load} (intrinsically safe)
- ⑤ Zener barrier / Voltage supply 8.0...30 VDC (intrinsically safe) and Output signal (4...20mA)



DANGER!

The transmitter may be operated in areas with potentially explosive atmospheres if the voltage supply is ensured by means of an associated apparatus.

5.1 NFC configuration and logging

The IPAQ 330 contains an NFC interface (applies only to later versions of IPAQ 330, see table on page 10) for communication with a smartphone app - INOR Connect. The configuration procedure uses the NFC function in combination with a smartphone with built-in NFC support to perform all settings of the transmitter. The transmitter does not need any power or other external connection, just to be close to the smartphone. The app makes it possible to read, write, save and share settings directly in the field.

The logging function give the possibility to log events directly in the field without any other equipment beside the smartphone. The logged data can be stored or shared by the mobile network. It makes it also very simple to read and display the actual measuring value in the transmitter.

The app does also give direct access to the transmitter documentation and calibration data through an internet connection.

NFC applies only to IPAQ 330 according to the table on page 10.

5.2 Factory settings for configuration

The transmitters are delivered with either a factory settings or configured according to customers' specifications.

Parameter	Factory settings
Type of sensor	RTD Pt100 $\alpha = 0.003850$
Number of wires	3
PV Lower range value	0
PV Upper range value	100
Temperature units	°C
Damping value	1.4s
Sensor break (Downscale/Upscale)	Upscale
Sensor short circuit (Downscale/Upscale)	Upscale

5.3 Configuration with ConSoft

The ConSoft is a PC based graphical user interface for configuration of the transmitters. The PC configuration software ConSoft is used for configuration, display and documentation. The current software versions of ConSoft and the USB interface are available for downloading on our website.

To upgrade your USB interface software to the latest version, use the following flow chart.

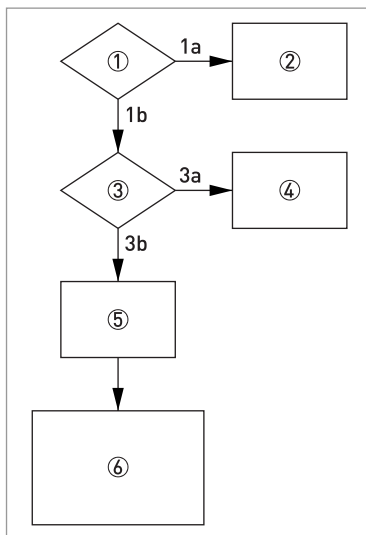

① Is the USB interface version 1.2.00 or higher?

1a No

1b Yes

② No possibility of updating for hardware version below 1.2.00. Replace the USB interface with newer version.

③ Is a ConSoft version 1.2.0.0 or higher installed on your PC?

3a No

3b Yes

④ Download the current ConSoft version from our website and install it on your PC.

⑤ Download the current software file [USB_x.y.zz.hex] for the USB interface from our website to your PC either on your desktop or in a folder made for this purpose.

⑥ 1. Start ConSoft

2. Connect the USB interface to the PC. Note that no other device should be connected during updating of the USB interface.

3. Click on Options/Update USB Interface/Load file (type the path for the software file downloaded on your desktop or in a separate folder).

4. Wait until "File OK" message is on the screen.

5. Click on "Start update". A message "Programming!" and a green status indicator show up on the screen. The update will take about one minute.

6. Wait until "Ready USB Interface" message is displayed on the screen. Close the update window. The USB interface is now ready for use.



Full functionality of the transmitter is achieved with ConSoft program version 3.2.0 or later and the firmware in the USB Interface must have a version number 1.2.07 or later. Consoft is compatible with Windows XP/Vista/7/8/8.1/10. The current software version of ConSoft and the USB interface are available for downloading on our website.



CAUTION!

Only use the manufacturer's configuration kit for PC configuration. Another configuration kit could destroy or damage the transmitter.



DANGER!

The transmitter's communication port (USB connection) may only be connected to the certified ICON-X Interface. When the ICON-X is connected, the temperature transmitter shall be outside of the hazardous area; a connected sensor may be located in the hazardous area.

For the applicable ambient temperature range, see the control drawings for C330X/R330X at the end of this book, and for ICON-X - 4006801801.

Proper connection of the transmitters with a PC requires our USB interface which is included in the ICON-X configuration kit. For connection of the transmitters refer to the following connection diagrams during configuration.



DANGER!

Make sure the area is safe before connecting the USB interface ICON-X to the transmitter.

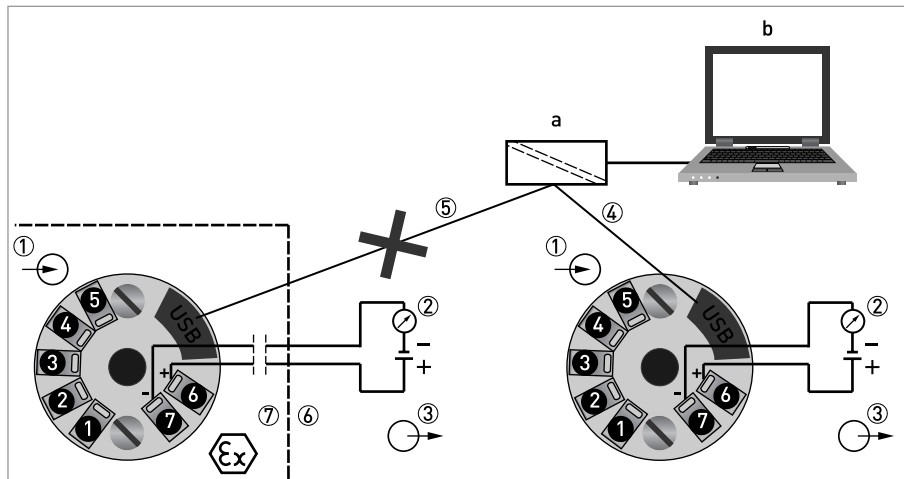

Figure 5-1: Connection during configuration of in-head transmitter

a = PC configuration kit; b = PC software ConSoft

- ① Input (intrinsically safe)
- ② R_{Load} (intrinsically safe)
- ③ Output voltage supply (intrinsically safe terminals 6 and 7)
- ④ Communication with USB interface and a PC software ConSoft
- ⑤ Connection to USB interface and a PC software ConSoft is not permitted if Ex version of IPAQ C330 (IPAQ C330X) is placed in the classified hazardous area (potentially explosive area)
- ⑥ Safe area
- ⑦ Classified hazardous area (potentially explosive area e.g. zone 0, 1 and 2 / DIV 1 and 2)

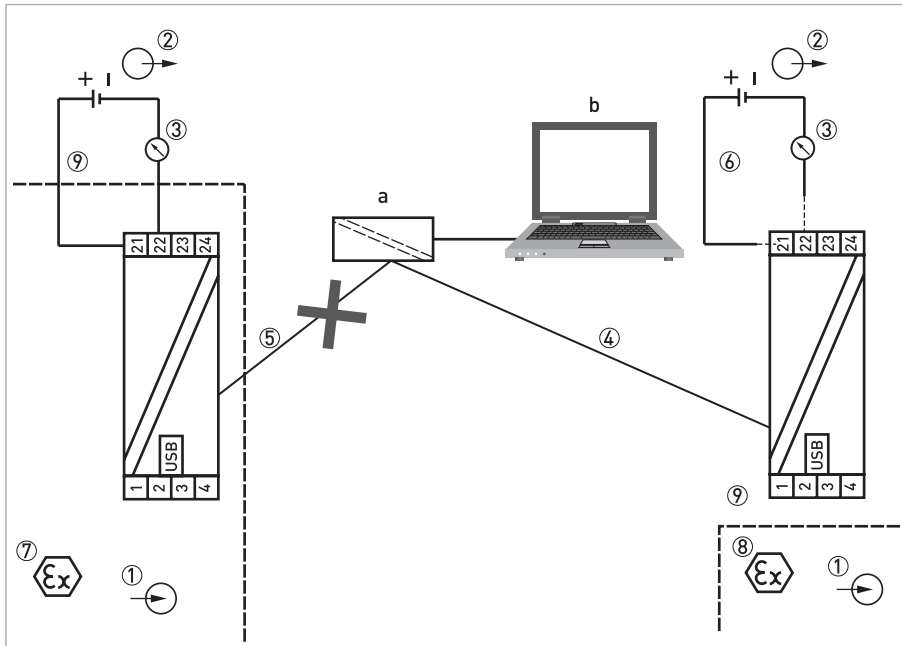

Figure 5-2: Connection during configuration of rail-mount transmitter

a = PC configuration kit; b = PC software ConSoft

- ① Input (intrinsically safe)
- ② Voltage supply (intrinsically safe terminals 21, 22)
- ③ R_{Load} (intrinsically safe)
- ④ Communication with USB interface and a PC software ConSoft
- ⑤ Connection to USB interface and a PC software ConSoft is not permitted if Ex version of IPAQ R330 (IPAQ R330X) is placed in the classified hazardous area (potentially explosive area)
- ⑥ Connection to the voltage supply during configuration with USB interface and PC software ConSoft is not needed
- ⑦ Classified hazardous area (potentially explosive area e.g. zone 0 / DIV 1)
- ⑧ Classified hazardous area (potentially explosive area e.g. zone 0, 1 and 2 / DIV 1 and 2)
- ⑨ Safe area

5.4 Diagnostic information according to NAMUR NE 107

Diagnostic information about the connected sensor is available in the configuration software ConSoft or via NFC when using a portable device.

In accordance with NAMUR NE 107 for:

- Sensor break (failure / sensor wire break)
- Sensor short-circuit (failure / sensor wire short-circuit)
- Transmitter error (failure/transmitter error, non-correctable in the transmitter)

For complete information about all diagnostic information available from the transmitters, connection to the chosen sensor and current loop should be established.

Messages in ConSoft		Actions
Device specific	Error message	Error correction
Device Specific Status additional device status information, which are described below.		
Transmitter	Underrange	Measurement is under specified range. Check the specified lower range and sensor and sensor connection. If error remains replace the sensor.
Transmitter	Overrange	Measurement is over specified range. Check the specified high range and sensor and sensor connection. If error remains replace the sensor.
Transmitter	Ad_short	See Sensor short circuit (same error cause).
Transmitter	Ad_open	See Sensor break (same error cause).
Transmitter	Sensor break	Sensor wire broken. Check the sensor and sensor connection. If error remains replace the sensor.
Transmitter	Sensor short circuit	Sensor wire shorted. Check the sensor and sensor. If error remains replace the sensor.
Transmitter	Sensor invalid	Invalid sensor selected. Check the sensor selection. If error remains replace device.
Transmitter	Linearization table invalid	Linearization table invalid. Check Linearization table settings. If error remains replace device.
Transmitter	Loop voltage too low	N/A
Transmitter	Dac out of range	Digital-to-Analog-Converter out of max range. Power cycle the device. If error remains replace device.
Transmitter	Dac feedback error (+/- 10%)	N/A
Transmitter	Loop resistance out of range	Loop Resistance out of range ($R_{Load} [\Omega] = (U-8.0)/0.022$). Check loop connection and voltage. If error remains replace device.
Transmitter	Dac acknowledge error	No acknowledge from Digital-to-Analog-Converter. Power cycle the device. If error remains replace device.
Transmitter	System non-recoverable errors	Internal system non-recoverable error. Power cycle the device. If error remains replace device.
Transmitter	Process	Maintenance required: Process
Transmitter	Configuration	Maintenance required: Configuration
Transmitter	Electronics	Maintenance required: Electronics
Transmitter	Sensor	Maintenance required: Sensor
Transmitter	Process	Out of Specification: Process
Transmitter	Configuration	Out of Specification: Configuration

Messages in ConSoft		Actions
Device specific	Error message	Error correction
Transmitter	Electronics	Out of Specification: Electronics
Transmitter	Sensor	Out of Specification: Sensor
Transmitter	Process	Check: Process
Transmitter	Configuration	Check: Configuration
Transmitter	Electronics	Check: Electronics
Transmitter	Sensor	Check: Sensor
Transmitter	Process	Failure: Process
Transmitter	Configuration	Failure: Configuration
Transmitter	Electronics	Failure: Electronics
Transmitter	Sensor	Failure: Sensor
Transmitter	High Alarm	Check the sensor and sensor connection. If error remains replace the sensor.
Transmitter	Low Alarm	Check the sensor and sensor connection. If error remains replace the sensor.

5.5 Factory default settings

The transmitters are delivered with a factory configuration Pt100 ($\alpha = 0.00385$), 3-wire connection 0...+100°C / +32...+212°F, sensor error monitoring "Upscale", filtering level 1.4 s or configured according to customer's requirements.

Due to the long-term drift of max. $\pm 0.02\%$ of span per year, a re-calibration of the transmitter is normally not needed. Should you for any reason require the re-calibration, the transmitter must be returned to the factory.

5.6 Sensor error monitoring

In case of a sensor break or short circuit the transmitter indicates this by either drop the output <3.6 mA or lift it to >21.0 mA. The sensor error indication is individually configurable and is set via the configuration software.

5.7 System or sensor error correction

System error correction

To perform a system error correction a dry block cell or a temperature bath together with a calibrated reference thermometer is needed. The system is the sensor + transmitter. Expose the sensor to one (one-point correction) or two (two-point correction) accurately measured temperatures (true temperatures), while the transmitter is connected to the configuration software. The true temperature(s) are entered into the software, and the transmitter automatically corrects for the system errors.

Sensor error correction

If the temperature sensor is calibrated, or the sensor error compared to the standard curve is known, then the sensor error (deviation from the standard curve) can be entered into the transmitter via the configuration software and the transmitter corrects for the sensor errors.

6.1 Accessory parts

Accessory part	Order code
Universal rail mounting kit for in-head version	70ADA00015
Ex configuration kit including Ex approved modem, software ConSoft and cables for USB connection.	70CFGUSX01
Connection Head installation kit	70ADA00017
ICON-BT, Bluetooth configuration kit	70CFGBT001

6.2 Spare parts availability

The manufacturer adheres to the basic principle that functionally adequate spare parts for each device or each important accessory part will be kept available for a period of 3 years after delivery of the last production run for the device.

This regulation only applies to spare parts which are subject to wear and tear under normal operating conditions.

6.3 Availability of services

The manufacturer offers a range of services to support the customer after expiration of the warranty. These include repair, maintenance, technical support and training.



For more precise information, please contact your local sales office.

6.4 Returning the device to the manufacturer

6.4.1 General information

This device has been carefully manufactured and tested. If installed and operated in accordance with these operating instructions, it will rarely present any problems.



WARNING!

Should you nevertheless need to return a device for inspection or repair, please pay strict attention to the following points:

- *Due to statutory regulations on environmental protection and safeguarding the health and safety of the personnel, the manufacturer may only handle, test and repair returned devices that have been in contact with products without risk to personnel and environment.*
- *This means that the manufacturer can only service this device if it is accompanied by the following certificate (see next section) confirming that the device is safe to handle.*



WARNING!

If the device has been operated with toxic, caustic, radioactive, flammable or water-endangering products, you are kindly requested:

- *to check and ensure, if necessary by rinsing or neutralising, that all cavities are free from such dangerous substances,*
- *to enclose a certificate with the device confirming that it is safe to handle and stating the product used.*

6.4.2 Form (for copying) to accompany a returned device



CAUTION!

To avoid any risk for our service personnel, this form has to be accessible from outside of the packaging with the returned device.

Company:		Address:	
Department:		Name:	
Telephone number:		Email address:	
Manufacturer order number or serial number:			
The device has been operated with the following medium:			
This medium is:	radioactive		
	water-hazardous		
	toxic		
	caustic		
	flammable		
	We checked that all cavities in the device are free from such substances.		
	We have flushed out and neutralized all cavities in the device.		
We hereby confirm that there is no risk to persons or the environment caused by any residual media contained in this device when it is returned.			
Date:		Signature:	
Stamp:			

6.5 Disposal



LEGAL NOTICE!

Disposal must be carried out in accordance with legislation applicable in your country.

Separate collection of WEEE (Waste Electrical and Electronic Equipment) in the European Union:



According to the directive 2012/19/EU, the monitoring and control instruments marked with the WEEE symbol and reaching their end-of-life **must not be disposed of with other waste.**

The user must dispose of the WEEE to a designated collection point for the recycling of WEEE or send them back to our local organisation or authorised representative.

6.5.1 Dispose of the transmitter

Dispose of the transmitter, sensor and packaging materials in an environmentally compatible way and in accordance with the country-specific waste disposal regulations.

6.5.2 Disassembling and recycling

This section describes (in short) the instructions of handling and disassembling the device when it's reached EOL (end of life) or is disposed after usage. The information given is sufficient to gather the most important parts of the device (by the end-user) which can be used for recycling.



The products do not contain dangerous gases or materials. If there is contamination from the process, refer to Returning the device to the manufacturer on page 32.

6.5.3 Disassembling and recycling of IPAQ C330/C330X

Type	IPAQ	
Model	C330 / C330X	
Usage	Signal conditioner for resistance and voltage	
	Weight [g]	Weight [lb]
Total	35.2	0.08
Metal parts	10.8	0.02
Ceramic fibers	0.3	0.00
Plastic parts	24.1	0.05

To achieve reliability and quality performance of the product IPAQ C330/C330X is encapsulated in casting polymer plastic resulting in that dismantling of the IPAQ C330/C330X is not possible. The content of the IPAQ C330/C330X can be found in the following table.

	Material	CAS	Weight [g]	Weight [%]
	Thermoplastic	NA	19.3	54.8
	Stainless steel	NA	5.2	14.8
	Brass	NA	3.5	9.9
	Zinc	7440-66-6	0.3	0.9
	Silicone	7440-21-3	0.8	2.3
	Epoxy	NA	3.6	10.2
	Lead free solder	NA	0.3	0.9
	Nitrile	NA	0.2	0.6
	Copper	7440-50-8	0.9	2.6
	Polyester	NA	0.2	0.6
	Nickel	7723-14-0	0.5	1.4
	Alumina (Al ₂ O ₃)	1344-28-1	0.2	0.6
	Gold (Au)	7444-57-6	0.1	0.3
	Barium titanat (BaTiO ₃)	12047-27-7	0.1	0.3

	Material	CAS	Weight [g]	Weight [%]
RoHS	Polybrominated diphenyl Ethers (PBDE)	NA	0	0
	Cadmium (Cd)	7440-43-9	0	0
	Mercury (Hg)	7439-97-6	0	0
	Lead (Pb)	7440-31-7	0	0
	Chrome VI (Cr VI)	7440-47-3	0	0
	Polybrominated biphenyls (PBB)	NA	0	0
	Bis (2-ethylhexil) phthalate (DEHP)	117-81-7	0	0
	Butyl benzyl phthalate (BBP)	85-68-7	0	0
	Dibutyl phthalate (DBP)	84-74-2	0	0
	Diisobutyl phthalate (DIBP)	84-69-5	0	0

6.5.4 Disassembling and recycling of IPAQ R330/R330X

Type	IPAQ	
Model	R330 / R330X	
Usage	Signal conditioner for resistance and voltage	
	Weight [g]	Weight [lb]
Total	63.8	0.14
Metal parts	9.4	0.02
Ceramic fibres	0.2	0.00
Plastic parts	54.2	0.12

To achieve reliability and quality performance of the product IPAQ R330/R330X is encapsulated in casting polymer plastic resulting in that dismantling of the IPAQ R330/R330X is not possible except the housing, which is sorted as plastic. The content of the IPAQ R330/R330X can be found in the following table.

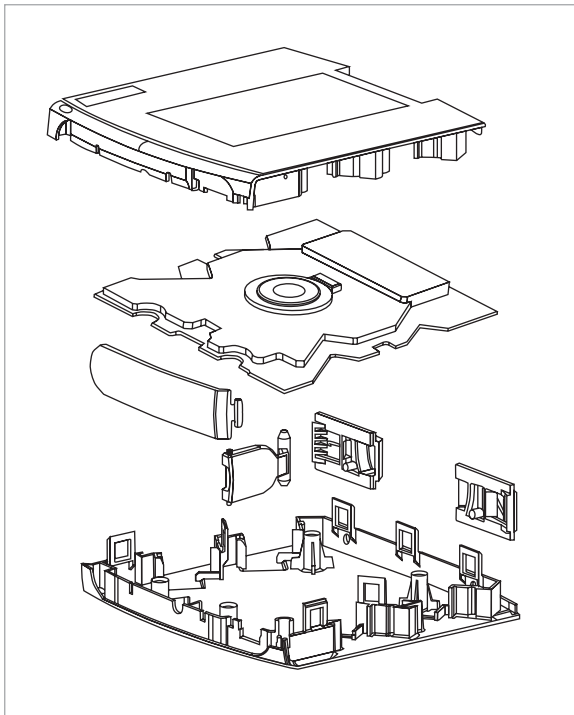

	Material	CAS	Weight [g]	Weight [%]
	Thermoplastic	NA	45.1	70.7
	Stainless steel	NA	4.3	6.7
	Brass	NA	3.2	5.0
	Zinc	7440-66-6	0.3	0.5
	Silicone	7440-21-3	0.8	1.3
	Epoxy	NA	8.1	12.7
	Lead free solder	NA	0.3	0.5
	Copper	7440-50-8	0.9	1.4
	Polyester	NA	0.2	0.3
	Nickel	7723-14-0	0.3	0.5
	Alumina (Al2O3)	1344-28-1	0.1	0.2
	Gold (Au)	7444-57-6	0.1	0.2
	Barium titanat (BaTiO3)	12047-27-7	0.1	0.2
RoHS	Polybrominated diphenyl Ethers (PBDE)	NA	0	0
	Cadmium (Cd)	7440-43-9	0	0
	Mercury (Hg)	7439-97-6	0	0
	Lead (Pb)	7440-31-7	0	0
	Chrome VI (Cr VI)	7440-47-3	0	0
	Polybrominated biphenyls (PBB)	NA	0	0
	Bis (2-ethylhexil) phthalate (DEHP)	117-81-7	0	0
	Butyl benzyl phthalate (BBP)	85-68-7	0	0
	Dibutyl phthalate (DBP)	84-74-2	0	0
	Diisobutyl phthalate (DIBP)	84-69-5	0	0

6.5.5 Packaging of IPAQ C330/C330X and R330/R330X

The products are delivered to the customers in corrugated cardboard boxes, which protect products against moisture and provides sustainable packaging solutions.

7.1 Measuring principles

The kind of the measuring principle depends on the measuring insert that you combine with the transmitter. In matters of the thermometer type the manufacturer offers two different measuring inserts, either with a resistance thermometer or with a thermocouple. This transmitter supports both types.

7.1.1 Resistance temperature sensor

The measuring insert with a temperature-sensitive sensor made from a platinum(Pt) RTD, whose value at 0°C / +32°F is 100 Ω. That is where the name "Pt100" comes from.

It is generally valid that the electric resistance of metals increases according to a mathematical function as the temperature rises. This effect is taken advantage of by resistance temperature sensors to measure temperature. The "Pt100" temperature sensors features a measuring resistance with defined characteristics, standardised in IEC 60751. The same is true for the tolerances. The average temperature coefficient of a Pt100 is $3.85 \times 10^{-3} \text{ K}^{-1}$ in the range from 0...+100°C / +32...+212°F.

During operation, a constant current $I (\leq 1 \text{ mA})$ flows through the Pt100 RTD, which brings about a voltage drop U . The resistance R is calculated using Ohm's Law ($R=U/I$). As the voltage drop U at 0°C / +32°F is 100 mV, the resulting resistance of the Pt100 temperature assembly is 100 Ω (100 mV / 1 mA = 100 Ω).

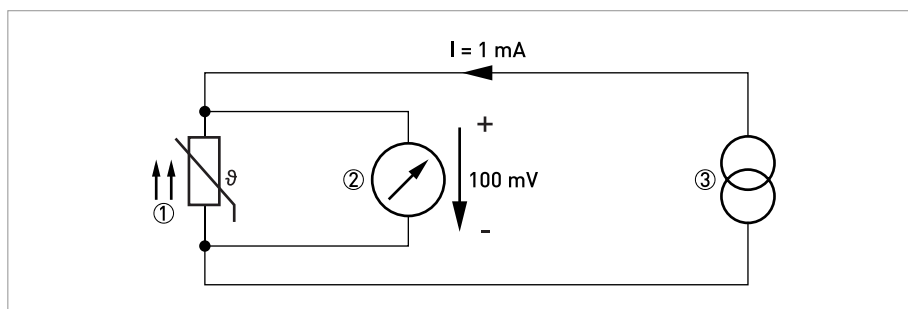

Figure 7-1: Pt100 resistance temperature sensor at 0°C / +32°F, schematic

- ① Pt100 RTD
- ② Voltage meter
- ③ Current source

7.1.2 Thermocouples

The thermocouple features two electric conductors made from different metals, connected at one end. Each free end is connected to a compensation cable which is then connected to a millivolt meter. This circuitry forms a "thermal circuit". The point at which the two electric conductors connect is called the measuring point and the point at which the compensation cables connect to the conductors of the millivolt meter is called the cold junction.

If the measuring point of this thermal circuit is heated up, a small electrical voltage (thermal voltage) can be measured. If, however, the measuring point and the cold junction are at the same temperature, no thermoelectric voltage is generated. The degree of thermoelectric voltage, also known as electromotive force (EMF), depends on the thermocouple material and the extent of the temperature difference between the measuring point and the cold junction. It can be measured using the millivolt meter with no auxiliary power.

Simply put, the thermocouple behaves like a battery, the voltage of which also increases as the temperature rises.



The characteristic curves and tolerances of commercially available thermocouples are standardised in IEC 60584.

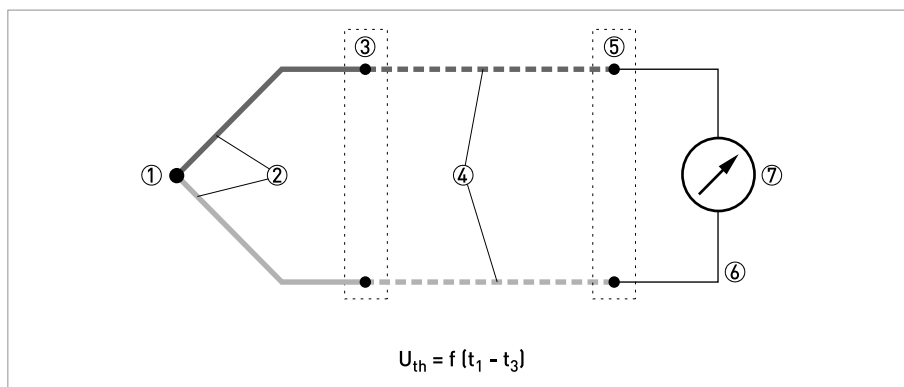

Figure 7-2: Thermocouple measuring circuit, schematic

- ① Measuring point t_1 (hot junction)
- ② Thermocouple
- ③ Transition junction t_2
- ④ Compensation cable / extension cable
- ⑤ Reference junction t_3 (cold junction)
- ⑥ Copper conductor
- ⑦ Voltage meter U_{th}

7.2 Technical data



- The following data is provided for general applications. If you require data that is more relevant to your specific application, please contact us or your local sales office.
- Additional information (certificates, special tools, software,...) and complete product documentation can be downloaded free of charge from the website.

Measuring system

Application range	Temperature measurements of solids, liquids and gases in industrial environment.
-------------------	--

Design

Versions	
C330	In-head transmitters which are intended for installation in a DIN B-head or larger according to DIN EN 50446. This transmitter is optionally available in an intrinsically safe version (zone 0, 1 and 2 / DIV 1 and 2) for installation in potentially explosive atmospheres.
R330	Rail-mount transmitters which are intended for installation on a DIN-rail according to DIN 50022 / EN 60715, 35 mm / 1.38". The transmitter is optionally available in an intrinsically safe version (zone 0, 1 and 2 / DIV 1 and 2) for installation in potentially explosive atmospheres.
Features	
NFC®	NFC® enables wireless communication and configuration between transmitter and a portable device such a smartphone. NFC applies only to later versions of IPAQ 330
Sensor matching	A matching to a calibrated temperature sensor can easily be performed by entering the sensor deviation in the low and high ends of the measuring ranges.
Customized linearization	For resistance and mV inputs, either a 50-point customized linearization table or via Callendar-Van Dusen (applies only to RTD, $\alpha = 0.00385$) constants can provide a correct process value.
PC programmable	Measuring ranges are set from PC.
	Full accuracy is provided without any need for calibration.
	Configuration without external power.
Runtime counter	Hour counter for elapsed operational time.
Simulated output	Fixed current output during a maximum time of 15 minutes.

Measuring accuracy

Accuracy & stability	Typical accuracy is max. of $\pm 0.08^\circ\text{C}$ or $\pm 0.08\%$ of span. (Pt100, 3- or 4-wire connection)
Ambient temperature influence	RTD and thermocouple: for detailed information refer to <i>RTD and T/C accuracy table</i> on page 49.
	Resistance: $\pm 0.01\% < 4000 \Omega$ (2000 Ω at 2-wire) $< \pm 0.02\%$ of span per $^\circ\text{C}$
	Voltage: $\pm 0.01\%$ of span per $^\circ\text{C}$
Supply voltage influence	$< \pm 0.005\%$ of span per V
Long-term drift	Max. of $\pm 0.02^\circ\text{C}$ or $\pm 0.02\%$ of span per year

Operating conditions

Temperature	
In-head transmitter	Operating and storage temperature: Standard version: -40...+85°C / -40...+185°F
	IS version: For permitted ambient temperature range, see page 46
Rail-mount transmitter	Operating and storage temperature: Standard version: -40...+85°C / -40...+185°F
	IS version: For permitted ambient temperature range, see page 46
Humidity	0...95% RH (non-condensing)
Protection category	
In-head transmitter	Housing: IP65
	Terminals: IP00
Rail-mount transmitter	Housing: IP20
	Terminals: IP20

Installation conditions

Mounting	In-head transmitter: DIN B-head or larger, DIN-rail (with adapter)
	Rail-mount transmitter: DIN-rail according to DIN 50022 / EN 60715, 35 mm / 1.38"
	For detailed information refer to <i>Installation</i> on page 14.
Weight	In-head transmitter: 35 g / 0.08 lb
	Rail-mount transmitter: 70 g / 0.15 lb
Dimensions	For detailed information refer to <i>Dimensions</i> on page 45.

Materials

Housing	PC/ABS + PA
Flammability according to UL	In-head transmitter: V0
	Rail-mount transmitter: V0/HB

Electrical connections

Power supply	Standard version: 8.0...36 VDC
	IS version: 8.0...30 VDC
Isolation	Galvanically isolated (in-out), 1500 VAC, 1 minute
Connection	Single/stranded wires: max. 1.5 mm ² / AWG 16
Reverse Polarity Protection	Yes

Inputs / Outputs

Input - RTD	
Pt100 (IEC 60751, $\alpha = 0.00385$)	-200...+850°C / -328...+1562°F
Pt100 (JIS C1604-1981, $\alpha = 0.003916$)	
PtX ($10 \leq X \leq 1000$) (IEC 60751, $\alpha = 0.00385$)	The upper range depends on the X value, max. input temperature corresponding to 4000 Ω .
Ni100 (DIN 43760)	-60...+250°C / -76...+482°F
Ni120 (Edison No. 7)	
Ni1000 (DIN 43760)	-50...+180°C / -58...+356°F

Cu10 (Edison Copper Windings No. 15)	-50...+200°C / -58...+392°F
Sensor current	≤300 µA
Maximum sensor wire resistance	3-wire and 4-wire connection: 50 Ω/wire 2-wire connection: Compensation for 0 to 100 Ω loop resistance
Adjustment	Minimum span 10°C / 18°F
	Sensor error compensation ±10% of span for span <50°C / 90°F, otherwise ±5°C / ±9°F
Input - resistance / potentiometer	
Range (resistance)	0...10000 Ω
Range (potentiometer)	100...10000 Ω
Zero adjustment	Within range
Max offset adjustment	50% of selected max. value
Minimum span	10 Ω
Sensor current	≤300 µA
Customized linearization	Up to 50 points
Maximum sensor wire resistance	In-head transmitter: 50 Ω/wire
	Rail-mount transmitter: 50 Ω/wire
Input - thermocouples	
T/C type B - Pt30Rh-Pt6Rh (IEC 60584)	400...+1800°C / +752...+3272°F
T/C type C - W5Re-W26Re (ASTM E 988)	0...+2315°C / 32...+4199°F
T/C type D - W3Re-W25Re (ASTM E 988)	0...+2315°C / 32...+4199°F
T/C type E - NiCr-CuNi (IEC 60584)	-270...+1000°C / -454...+1832°F
T/C type J - Fe-CuNi (IEC 60584)	-210...+1200°C / -346...+2192°F
T/C type K - NiCr-NiAl (IEC 60584)	-270...+1300°C / -454...+2372°F
T/C type N - NiCrSi-NiSi (IEC 60584)	-270...+1300°C / -454...+2372°F
T/C type R - Pt13Rh-Pt (IEC 60584)	-50...+1750°C / -58...+3182°F
T/C type S - Pt10Rh-Pt (IEC 60584)	-50...+1750°C / -58...+3182°F
T/C type T - Cu-CuNi (IEC 60584)	-270...+400°C / -454...+752°F
Input impedance	>10 MΩ
Maximum wire loop resistance	In-head transmitter (including T/C sensor): 5 kΩ
	Field transmitter (including T/C sensor): 10 kΩ
Cold Junction Compensation (CJC)	Internal, external (Pt100) or fixed
Input - voltage	
Range	-10...+1000 mV
Zero adjustment	Within range
Minimum span	2 mV
Customized linearization	Up to 50 points
Input impedance	>10 MΩ
Maximum wire loop resistance	In-head transmitter: 5 kΩ
	Field transmitter / Switch room transmitter: 10 kΩ
Output	
Output signal	4...20 mA, 20...4 mA; temperature, resistance or voltage linear, customized linearization possible.
Permissible load	(Supply voltage-8,0)/0.022
NAMUR compliance	Output limits and failure currents according to NAMUR NE 43

Adjustable filtering level	0.17...90 s, (default 1.4s) (3-wire RTD)
Monitoring	Sensor break and short circuit monitoring, selectable, upscale ≥ 21.0 mA or downscale ≤ 3.6 mA action, individually configurable.
Configuration	
ConSoft	The PC configuration software, ConSoft, is a versatile and user-friendly tool for transmitter configuration.
	ConSoft is compatible with Windows XP/Vista/7/8/8.1/10
	ConSoft is part of the complete configuration kit, which also contains a USB interface and necessary cables. Full functionality of the transmitter is achieved with ConSoft program version 3.4.0 or later and the firmware in the USB Interface must have a version number 1.2.07 or later.
INOR connect	The app INOR Connect for portable devices (smartphones) is a versatile and user-friendly tool for wireless configuration through Bluetooth® or NFC® technology. Communication via Bluetooth® requires the Bluetooth® interface - ICON-BT, which can be ordered from the manufacturer.

Approvals and certifications

CE	The device fulfils the statutory requirements of the EU directives. The manufacturer certifies that these requirements have been met by applying the CE marking.
Ex approvals	
Standard version	Without
Intrinsically safe (IS) version	Refer to Ex approvals in the separate table below.
Other standards and approvals	
Electromagnetic compatibility	Directive: 2014/30/EU
	Harmonized standards: EN 61326-1 and EN 61326-2-3
	NAMUR NE 21
	EN 61326-1 and -2-3: Criteria A NE 21: <0.5% of span
RoHS	Directive: 2011/65/EU Harmonized standard: EN 50581
Vibration resistance	According to IEC 60068-2-6, test Fc, 10...2000 Hz, 10 g for in-head mounted / 5 g for rail mounted transmitter
Radio Equipment Directive	This product contains NFC communication and conforms to the requirements of the Radio Equipment Directive (RED) 2014/53/EU

Ex approvals

C330X (intrinsically safe), part no. 70C330X010 and 70C330X012		
ATEX	KIWA 16ATEX0038 X	II 1 G Ex ia IIC T6...T4 Ga
IECEX	IECEX KIWA 16.0016X	Ex ia IIC T6...T4 Ga
USA	FM17US0283X	Cl I DIV 1 GP A-D, T6...T4 Cl I Zn 0 AEx/Ex ia IIC T6...T4 Ga
Canada	FM17CA0144X	
R330X (intrinsically safe), part no. 70R330X010 and 70R330X012		
ATEX	KIWA 16ATEX0040 X	II 1 G Ex ia IIC T6...T4 Ga
IECEX	IECEX KIWA 16.0018X	Ex ia IIC T6...T4 Ga
USA	FM17US0283X	Cl I DIV 1 GP A-D, T6...T4 Cl I Zn 0 AEx/Ex ia IIC T6...T4 Ga
Canada	FM17CA0144X	

7.3 Dimensions

In-head transmitter

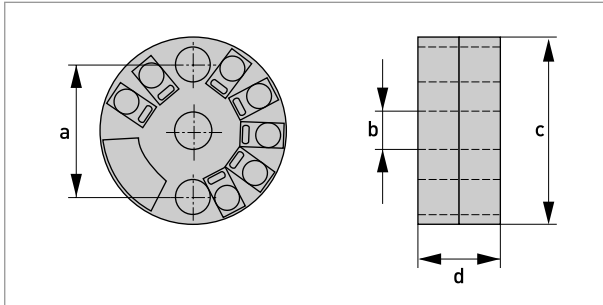

	Dimensions	
	[mm]	[inch]
a	33.0	1.30
b	7.0	0.28
c	44.5	1.75
d	19.7	0.78

Rail-mount transmitter

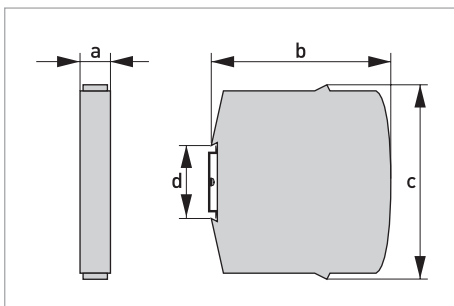

	Dimensions	
	[mm]	[inch]
a	17.5	0.69
b	81.3	3.20
c	90.0	3.54
d	35	1.38

7.4 Temperature data for areas with potentially explosive atmospheres

Intrinsically safe in head and rail mount transmitter

C330X, part no. 70C330X010

R330X, part no. 70R330X010

Temperature class	Allowed ambient temperature
T6	$-40^{\circ}\text{C} \leq T_a \leq +60^{\circ}\text{C}$ / $-40^{\circ}\text{F} \leq T_a \leq +140^{\circ}\text{F}$
T5	$-40^{\circ}\text{C} \leq T_a \leq +75^{\circ}\text{C}$ / $-40^{\circ}\text{F} \leq T_a \leq +167^{\circ}\text{F}$
T4	$-40^{\circ}\text{C} \leq T_a \leq +85^{\circ}\text{C}$ / $-40^{\circ}\text{F} \leq T_a \leq +185^{\circ}\text{F}$

C330X, part no. 70C330X012

R330X, part no. 70R330X012

Pi	Temperature class	Allowed ambient temperature
900 mW	T6	$-40^{\circ}\text{C} \leq T_a \leq +55^{\circ}\text{C}$ / $-40^{\circ}\text{F} \leq T_a \leq +131^{\circ}\text{F}$
	T5	$-40^{\circ}\text{C} \leq T_a \leq +70^{\circ}\text{C}$ / $-40^{\circ}\text{F} \leq T_a \leq +158^{\circ}\text{F}$
	T4	$-40^{\circ}\text{C} \leq T_a \leq +85^{\circ}\text{C}$ / $-40^{\circ}\text{F} \leq T_a \leq +185^{\circ}\text{F}$
700 mW	T6	$-40^{\circ}\text{C} \leq T_a \leq +60^{\circ}\text{C}$ / $-40^{\circ}\text{F} \leq T_a \leq +140^{\circ}\text{F}$
	T5	$-40^{\circ}\text{C} \leq T_a \leq +75^{\circ}\text{C}$ / $-40^{\circ}\text{F} \leq T_a \leq +167^{\circ}\text{F}$
	T4	$-40^{\circ}\text{C} \leq T_a \leq +85^{\circ}\text{C}$ / $-40^{\circ}\text{F} \leq T_a \leq +185^{\circ}\text{F}$

7.5 Output load diagram

Formula for the maximum permissible output load:
 permissible $R_{Load} [\Omega] = (U-8.0)/0.022$

Standard transmitter

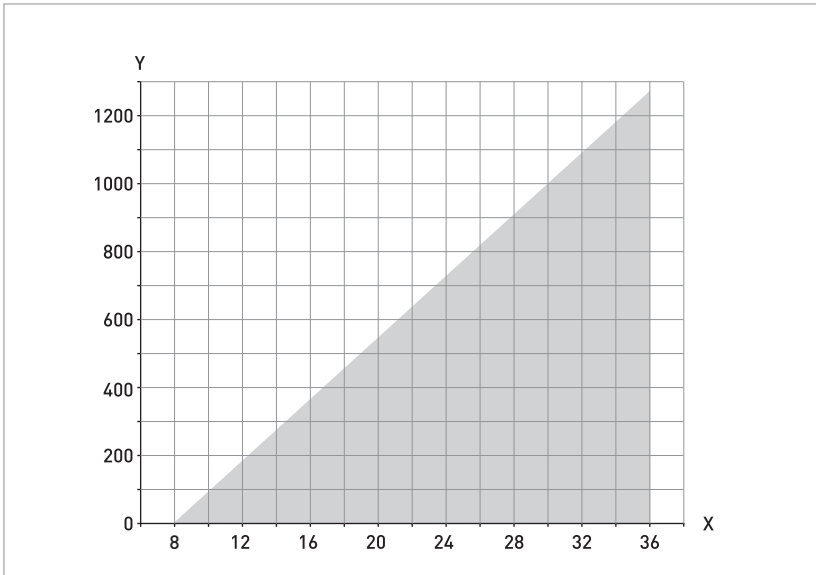

Figure 7-3: Output load diagram

X: Power supply U [VDC]
 Y: Total output load R [Ω]

Formula for the maximum permissible output load:
 permissible $R_{Load} [\Omega] = (U-8.0)/0.022$

Intrinsically safe transmitter

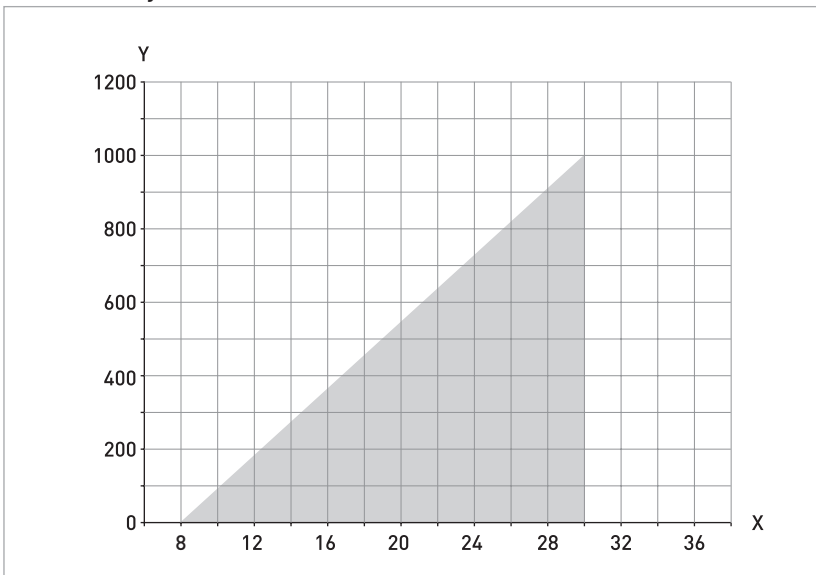

Figure 7-4: Output load diagram

X: Power supply U [VDC]
 Y: Total output load R [Ω]

7.6 Electrical data for outputs and inputs

In-head transmitter

Intrinsically safe transmitter, C330X - Part number 70C330X010

Output terminals 6, 7		Input terminals 1, 2, 3, 4	
$U_i = V_{max}$	≤ 30 VDC	$U_o = U_{oc}$	≤ 30 VDC
$I_i = I_{max}$	≤ 100 mA	$I_o = I_{sc}$	≤ 54 mA
$P_i = P_{max}$	≤ 900 mW	P_o	≤ 405 mW
L_i	20 μ H	L_o	11 mH
C_i	23.1 nF	C_o	38.1 nF

Intrinsically safe transmitter, C330X - Part number 70C330X012

Output terminals 6, 7		Input terminals 1, 2, 3, 4	
$U_i = V_{max}$	≤ 30 VDC	$U_o = U_{oc}$	≤ 6.5 VDC
$I_i = I_{max}$	≤ 100 mA	$I_o = I_{sc}$	≤ 11.7 mA
$P_i = P_{max}$	≤ 900 mW	P_o	≤ 19.1 mW
L_i	20 μ H	L_o	400 mH
C_i	23.1 nF	C_o	24 μ F

Rail-mount transmitter

Intrinsically safe transmitter, R330X - Part number 70R330X010

Output terminals 21, 22		Input terminals 1, 2, 3, 4	
$U_i = V_{max}$	≤ 30 VDC	$U_o = U_{oc}$	≤ 30 VDC
$I_i = I_{max}$	≤ 100 mA	$I_o = I_{sc}$	≤ 54 mA
$P_i = P_{max}$	≤ 900 mW	P_o	≤ 405 mW
L_i	20 μ H	L_o	11 mH
C_i	23.1 nF	C_o	38.1 nF

Intrinsically safe transmitter, R330X - Part number 70R330X012

Output terminals 21, 22		Input terminals 1, 2, 3, 4	
$U_i = V_{max}$	≤ 30 VDC	$U_o = U_{oc}$	≤ 6.5 VDC
$I_i = I_{max}$	≤ 100 mA	$I_o = I_{sc}$	≤ 11.7 mA
$P_i = P_{max}$	≤ 900 mW	P_o	≤ 19.1 mW
L_i	20 μ H	L_o	400 mH
C_i	23.1 nF	C_o	24 μ F

7.7 RTD and T/C accuracy table

Typical accuracy $\pm 0.08\%$ of span, max. of ± 0.1 K or $\pm 0.1\%$ of span. (Pt100, 3- or 4-wire connection)

Conformance level 95% (2σ)

CJC = Cold Junction Compensation

Accuracies in °C

Input type	Temp. range	Min. span	Accuracy (maximum of)	Temp. influence (Dev. from ref. temp. 20°C)
	[°C]	[°C]	[°C]	
RTD Pt100	-200...+850	10	$\pm 0.08^\circ\text{C}$ or $\pm 0.08\%$ of span ①	$\pm 0.01\%$ of span per °C
RTD PtX ②	Corresp. to max. 4 kΩ	10	$\pm 0.1^\circ\text{C}$ or $\pm 0.1\%$ of span ①	$\pm 0.01\%$ of span per °C ③
RTD Ni100	-60...+250	10	$\pm 0.1^\circ\text{C}$ or $\pm 0.1\%$ of span ①	$\pm 0.01\%$ of span per °C
RTD Ni120	-60...+250	10	$\pm 0.1^\circ\text{C}$ or $\pm 0.1\%$ of span ①	$\pm 0.01\%$ of span per °C
RTD Ni1000	-50...+180	10	$\pm 0.1^\circ\text{C}$ or $\pm 0.1\%$ of span ①	$\pm 0.01\%$ of span per °C ③
RTD Cu10	-50...+200	83	$\pm 1.5^\circ\text{C}$ or $\pm 0.2\%$ of span ①	$\pm 0.02\%$ of span per °C
T/C type B	+400...+1800	700	$\pm 1.0^\circ\text{C}$ or $\pm 0.2\%$ of span ④	$\pm 0.01\%$ of span per °C
T/C type C	0...+2315	200	$\pm 1.0^\circ\text{C}$ or $\pm 0.2\%$ of span ④	$\pm 0.01\%$ of span per °C
T/C type D	0...+2315	200	$\pm 1.0^\circ\text{C}$ or $\pm 0.2\%$ of span ④	$\pm 0.01\%$ of span per °C
T/C type E	-270...+1000	50	$\pm 0.5^\circ\text{C}$ or $\pm 0.1\%$ of span ④	$\pm 0.01\%$ of span per °C
T/C type J	-210...+1200	50	$\pm 0.5^\circ\text{C}$ or $\pm 0.1\%$ of span ④	$\pm 0.01\%$ of span per °C
T/C type K	-270...+1300	50	$\pm 0.5^\circ\text{C}$ or $\pm 0.1\%$ of span ④	$\pm 0.01\%$ of span per °C
T/C type N	-100...+1300	100	$\pm 0.5^\circ\text{C}$ or $\pm 0.1\%$ of span ④	$\pm 0.01\%$ of span per °C
T/C type N	-270...-100	100	$\pm 1.0^\circ\text{C}$ ④	$\pm 0.1\%$ of span per °C
T/C type R	-50...+1750	300	$\pm 1.0^\circ\text{C}$ or $\pm 0.1\%$ of span ④	$\pm 0.01\%$ of span per °C
T/C type S	-50...+1750	300	$\pm 1.0^\circ\text{C}$ or $\pm 0.1\%$ of span ④	$\pm 0.01\%$ of span per °C
T/C type T	-270...+400	50	$\pm 0.25^\circ\text{C}$ or $\pm 0.2\%$ of span ④	$\pm 0.01\%$ of span per °C

① Valid for 3- and 4-wire connection. For factory settings Pt100, 3-wire connection, 0...100°C applies $\pm 0.05^\circ\text{C}$.

② ($10 \leq X \leq 1000$)

③ For 2-wire connection and span $> 2000 \Omega$ applies $\pm 0.02\%$ of span per °C

④ CJC error not included. $\leq 0.5^\circ\text{C}$ within ambient temperature range

Accuracies in °F

Input type	Temp. range	Min. span	Accuracy (maximum of)	Temp. influence (Dev. from ref. temp. 68°F)
	[°F]	[°F]	[°F]	
RTD Pt100	-328...+1562	18	±0.14°F or ±0.08% of span ①	±0.006% of span per °F
RTD PtX ②	Corresp. to max. 4 kΩ	18	±0.18°F or ±0.1% of span ①	±0.006% of span per °F ③
RTD Ni100	-76...+482	18	±0.18°F or ±0.1% of span ①	±0.006% of span per °F
RTD Ni120	-76...+482	18	±0.18°F or ±0.1% of span ①	±0.006% of span per °F
RTD Ni1000	-58...+356	18	±0.18°F or ±0.1% of span ①	±0.006% of span per °F ③
RTD Cu10	-58...+392	149	±2.7°F or ±0.2% of span ①	±0.006% of span per °F
T/C type B	+752...+3272	1260	±1.8°F or ±0.1% of span ④	±0.006% of span per °F
T/C type C	+32...+4199	360	±1.8°F or ±0.1% of span ④	±0.006% of span per °F
T/C type D	+32...+4199	360	±1.8°F or ±0.1% of span ④	±0.006% of span per °F
T/C type E	-454...+1832	90	±0.9°F or ±0.1% of span ④	±0.006% of span per °F
T/C type J	-346...+2192	90	±0.9°F or ±0.1% of span ④	±0.006% of span per °F
T/C type K	-454...+2372	90	±0.9°F or ±0.1% of span ④	±0.006% of span per °F
T/C type N	-148...+2372	180	±0.9°F or ±0.1% of span ④	±0.006% of span per °F
T/C type N	-454...-148	180	±1.8°F ④	±0.18% of span per °F
T/C type R	-58...+3182	540	±1.8°F or ±0.1% of span ④	±0.006% of span per °F
T/C type S	-58...+3182	540	±1.8°F or ±0.1% of span ④	±0.006% of span per °F
T/C type T	-454...+752	90	±0.9°F or ±0.1% of span ④	±0.006% of span per °F

① Valid for 3-wire, 4-wire connection. For factory settings Pt100, 3-wire, 32-212 °F applies ±0.09 °F.

② (10 ≤ X ≤ 1000)

③ For 2-wire connection and span >2000 Ω applies ±0.02% of span per 1.8° F

④ CJC error not included. ≤ 0.9°F within ambient temperature range

8.1 Installation and control drawings

IPAQ	Part Number	Control drawing
C330X ①	70C330X010	4005488501
C330X ②	70C330X012	4005488502
R330X ①	70R330X010	4005499601
R330X ②	70R330X012	4005499602

① Without NFC interface

② With NFC interface

This drawing is property of Inor Process AB, Malmö, Sweden, without whose permission it may not be copied, and the contents thereof must not be imparted to third party nor be used for any unauthorized purpose. Continuation will be conscribed.

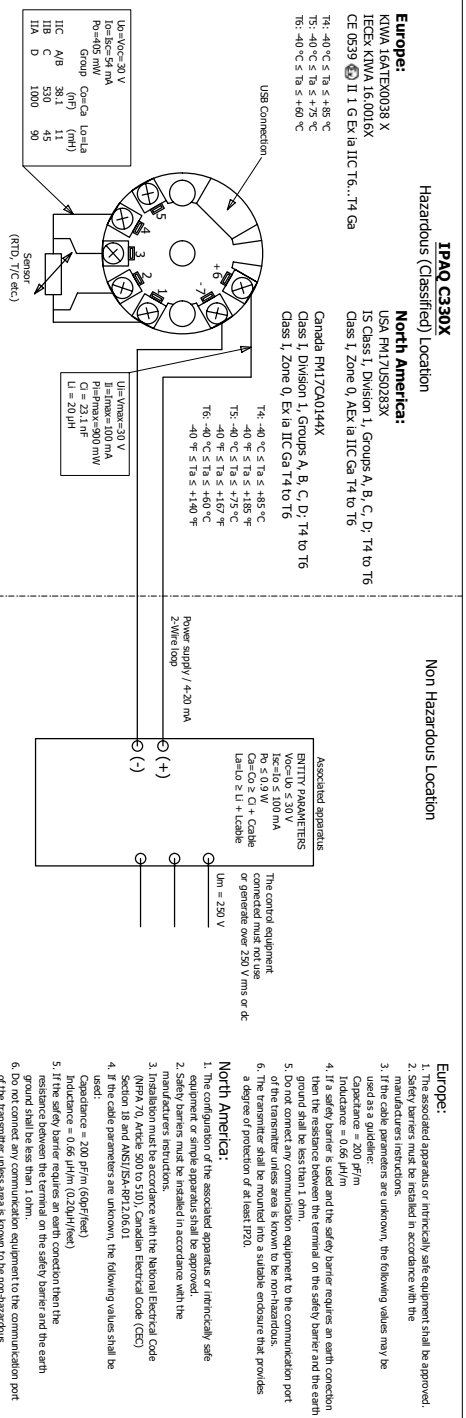

Data (short form)

Input	RTD, T/C, mV and Ohm
Connection type	2-, 3-, and 4-wire, Pot/Side wire
Range configuration	PC-programmable
Configuration	Multifunctional with wide measuring ranges
Measuring ranges	
Sensor monitoring	Upscale (±21.0 mA) or downscale (±3.6 mA)
Sensor break	Upscale (±21.0 mA) or downscale (±3.6 mA)
Sensor short circuit	8 to 30 VDC for IPAQ C330X
Power supply	Analog +20 mA, temperature linear
Output	1500 VAC (Signal isolation)
Isolation in-out	

Rev 3	180615	CFRUS added, Co group IIA=1000 nF	GP
Rev 2	170120	Changed value for Co	GP
Rev 1	161123	First release, revision	GP
Revision	DATE	CHANGE	APPROVED BY

QTY	QUANTITY	ATX, IECEx and CFRUS	1000375591	4005488501
DESIGN	DESIGN	IPAQ C330X		
TITLE	TITLE	Installation and control drawing		
NO	NO	IPAQ C330X		
SCALE	SCALE	Temperature transmitter		
DATE	DATE	2016-11-23		
DESIGNED BY	DESIGNED BY	GP		
CHECKED BY	CHECKED BY	GP		
NO OF SHEETS	NO OF SHEETS	1		
SHEET NO	SHEET NO	1		
DOC. NO.	DOC. NO.	4005488501		
REV	REV	ZZ		
NO	NO	3		

Ex-document, may not be revised without approval from the Certification Body.

This drawing is property of Inor Process AB, Malmö, Sweden, without whose permission it may not be copied, and the contents thereof must not be imparted to third party nor be used for any unauthorized purpose. Continuation will be appointed.

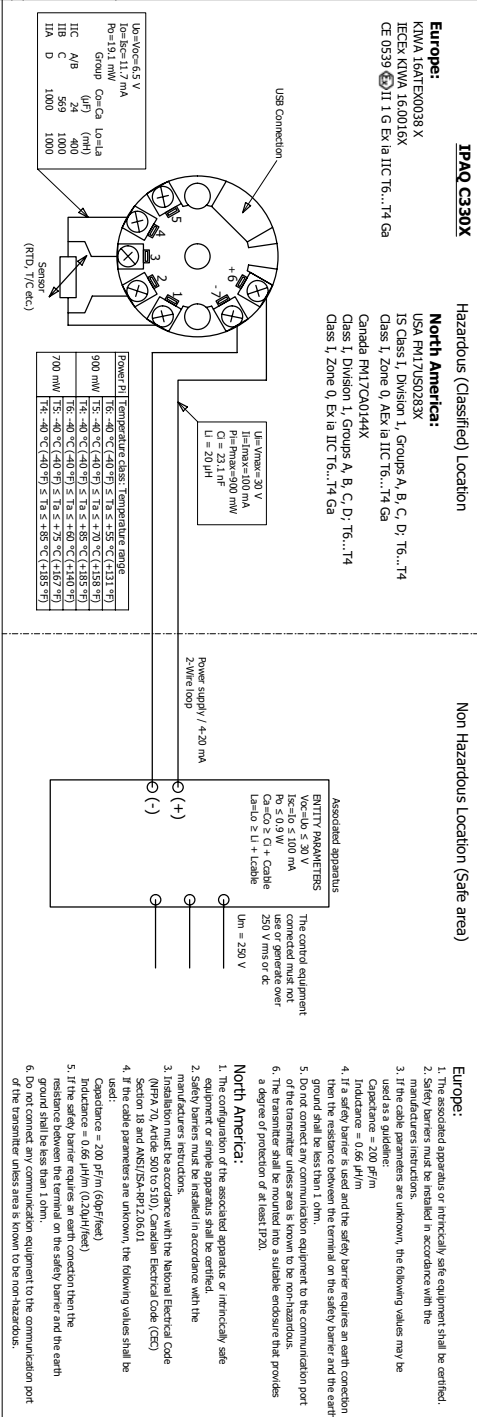

Rev 2	190923	CFMUs added, new values for Ta	GP	Approved by:	
Rev 1	181030	First release, revision	GP	Approved by:	
Revision	DATE	CHANGE	APPROVED BY		

Doc. No.	QUANTITY	UNIT	QTY	UNIT PRICE	TOTAL PRICE
4005488502	1	EA	1	4005488502	4005488502

KROHNE
INOR
SWEDEN

Installation and control drawing
 IPAQ C330X
 Temperature Transmitter

Scale: 1:1

Doc. No.: 4005488502

Doc. Type: ZZ

Revision: 2

Ex-document, may not be revised without approval from the Certification Body.

This drawing is property of Inor Process AB, Malmö, Sweden, without whose permission it may not be copied, and the contents thereof must not be imparted to third party nor be used for any unauthorized purpose. Copying without permission is prohibited.

